

FLEXTEC 350 WIRING SCHEMATIC G8141-1 REV: A

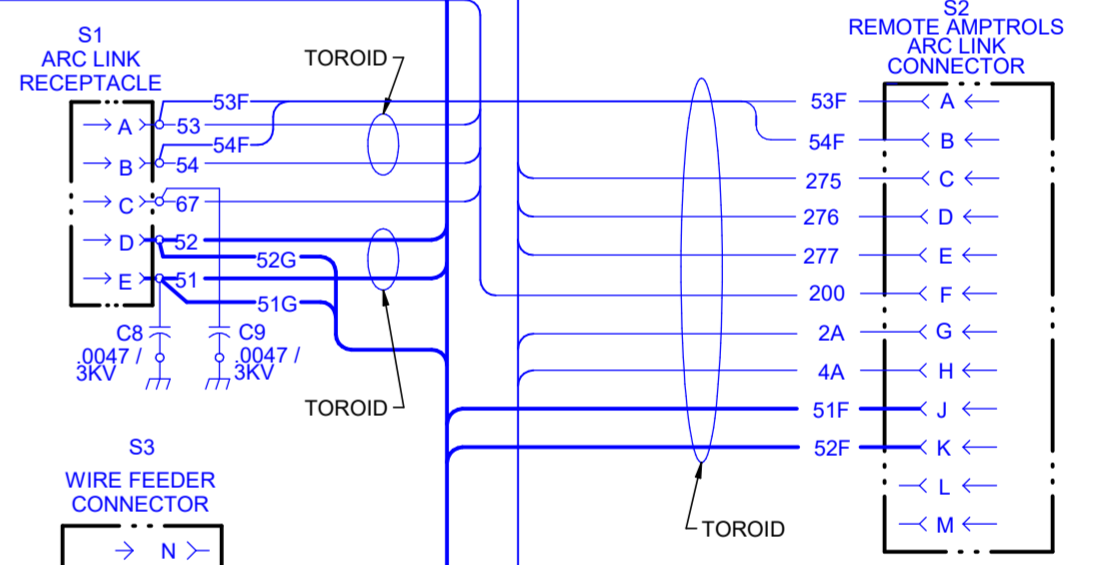

NOTES:
 N.A. PIN NEAREST THE FLAT EDGE OF LED LENS ALIGNS WITH WHITE LEAD OF LED SOCKET.
 N.B. LEDs ARE ONLY ACTIVE IF VRD IS TURNED ON. TURN ON VRD BY PLACING DIP SWITCH 5 ON CONTROL BOARD IN THE "ON" POSITION.
 N.C. ONE CHOKE PER WIRE.
 N.D. ELECTRICAL SYMBOLS PER E1537.
 N.E. TWO CHOKES PER WIRE.

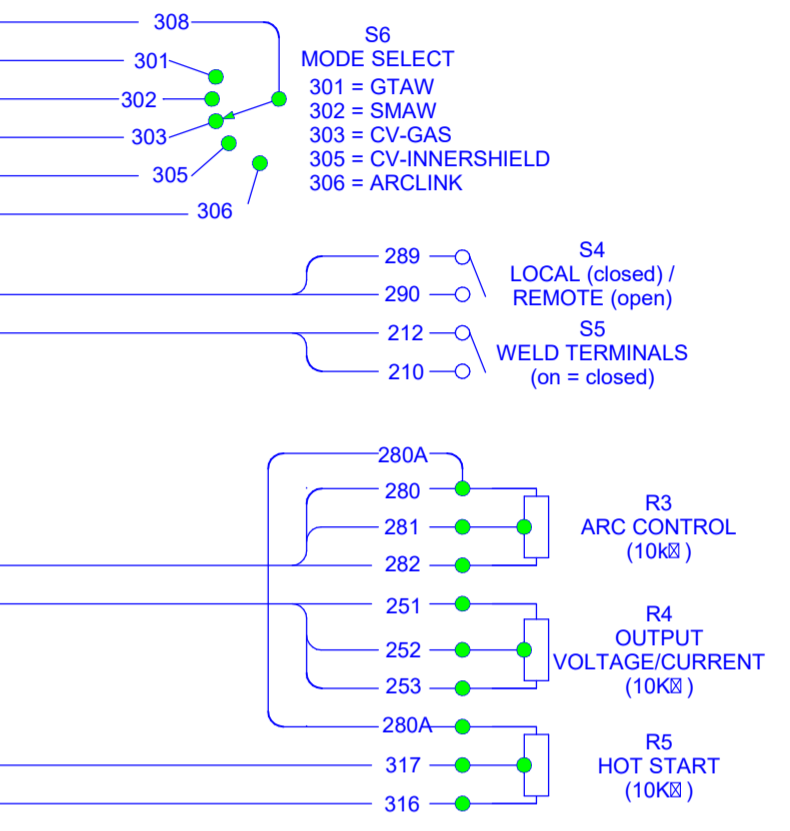
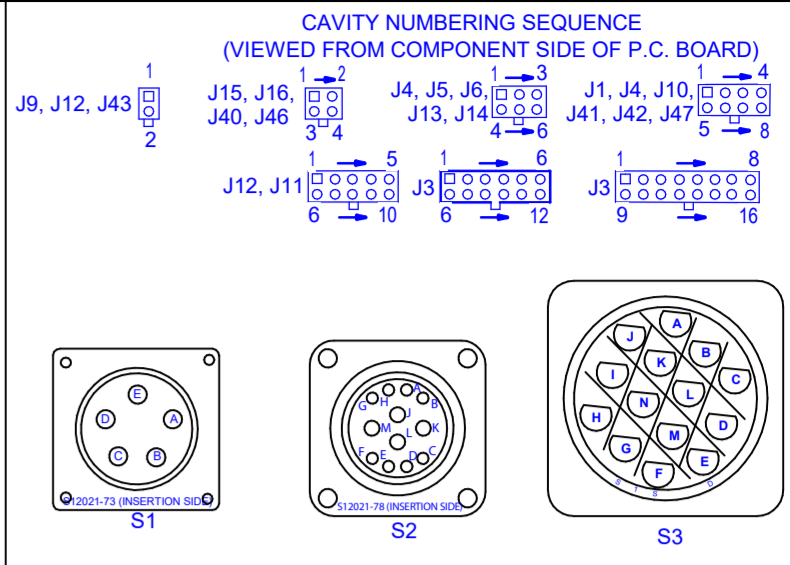
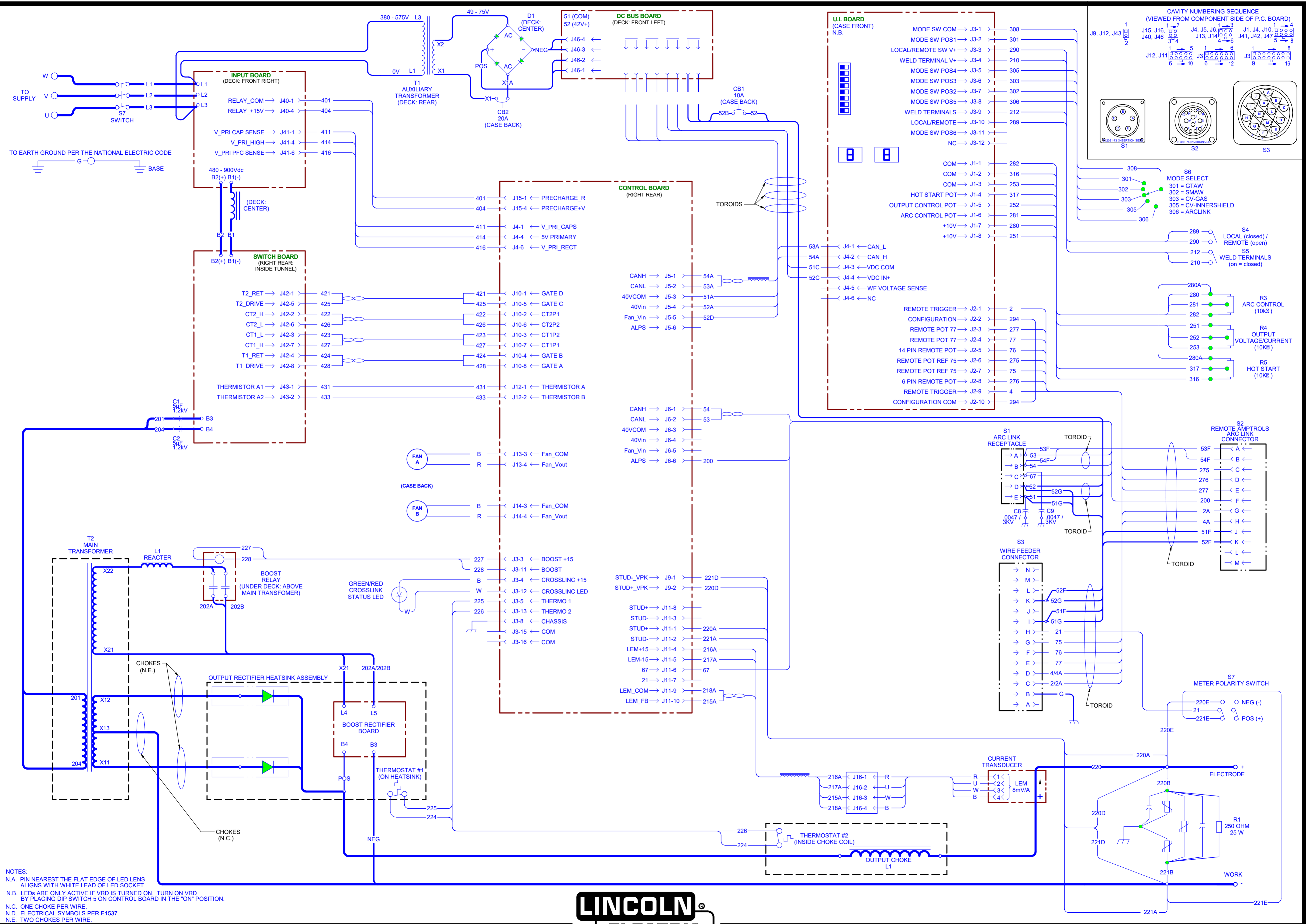

SWITCHBOARD

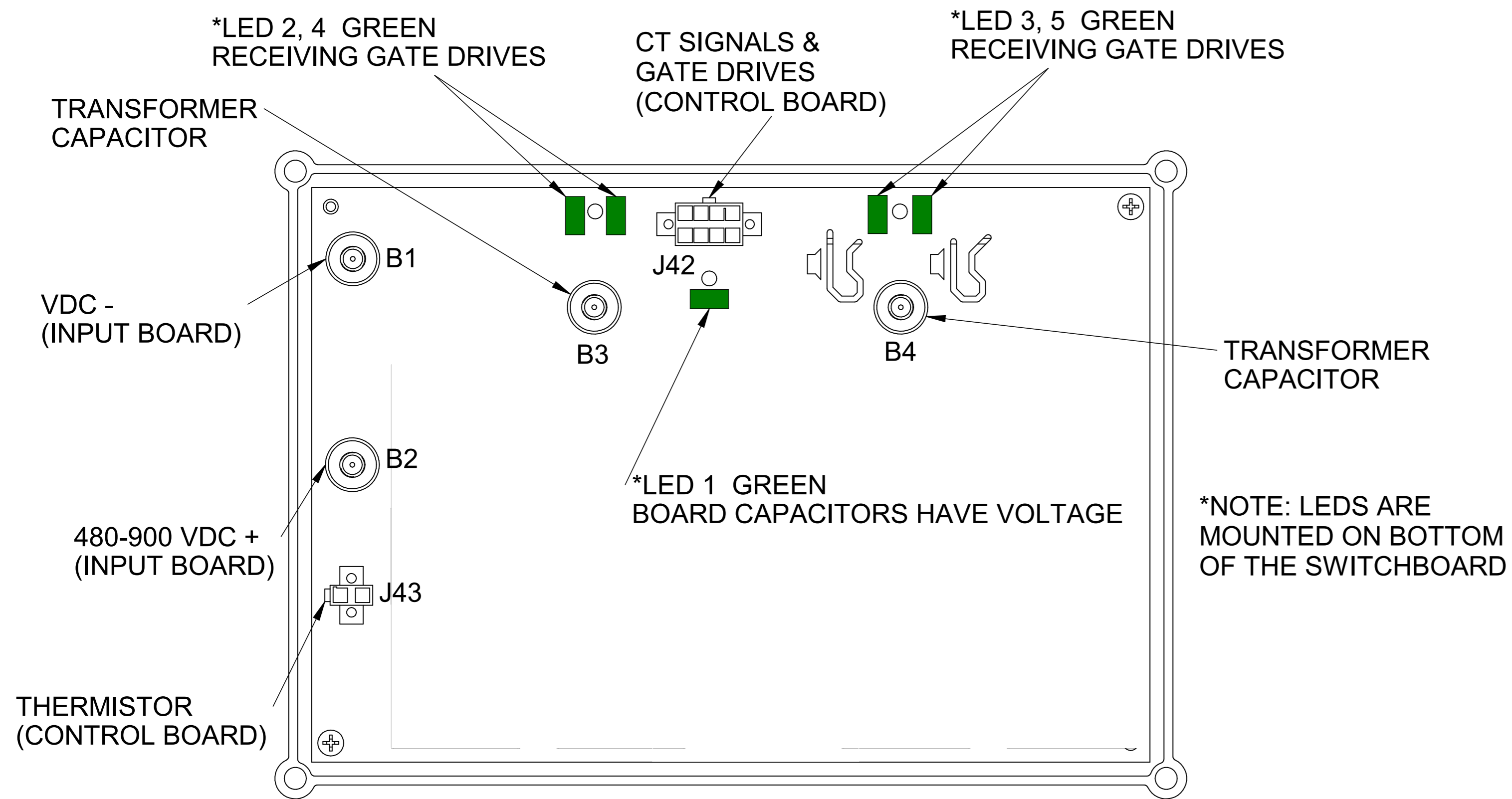

INPUT P.C. BOARD

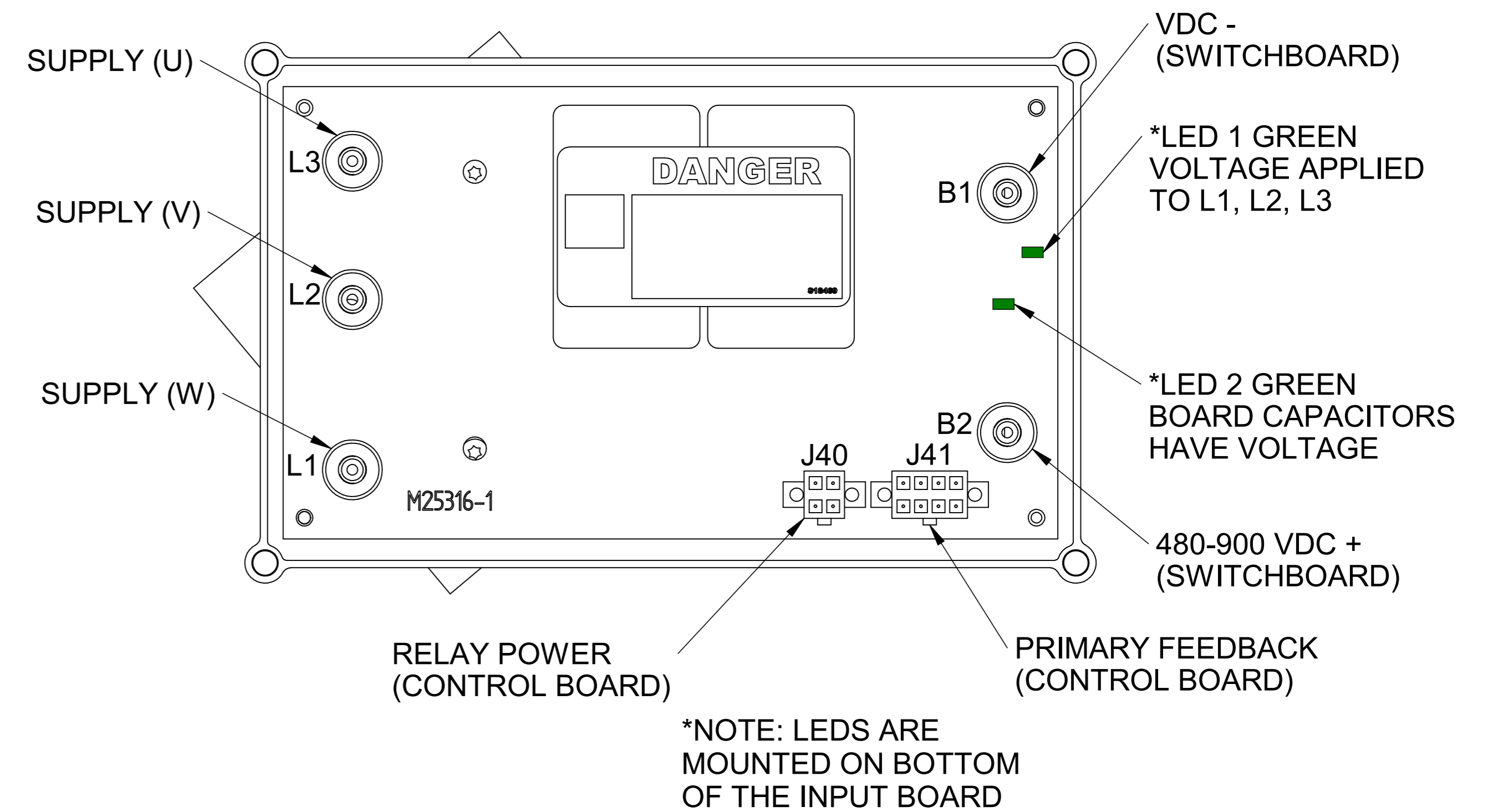

CONTROL BOARD

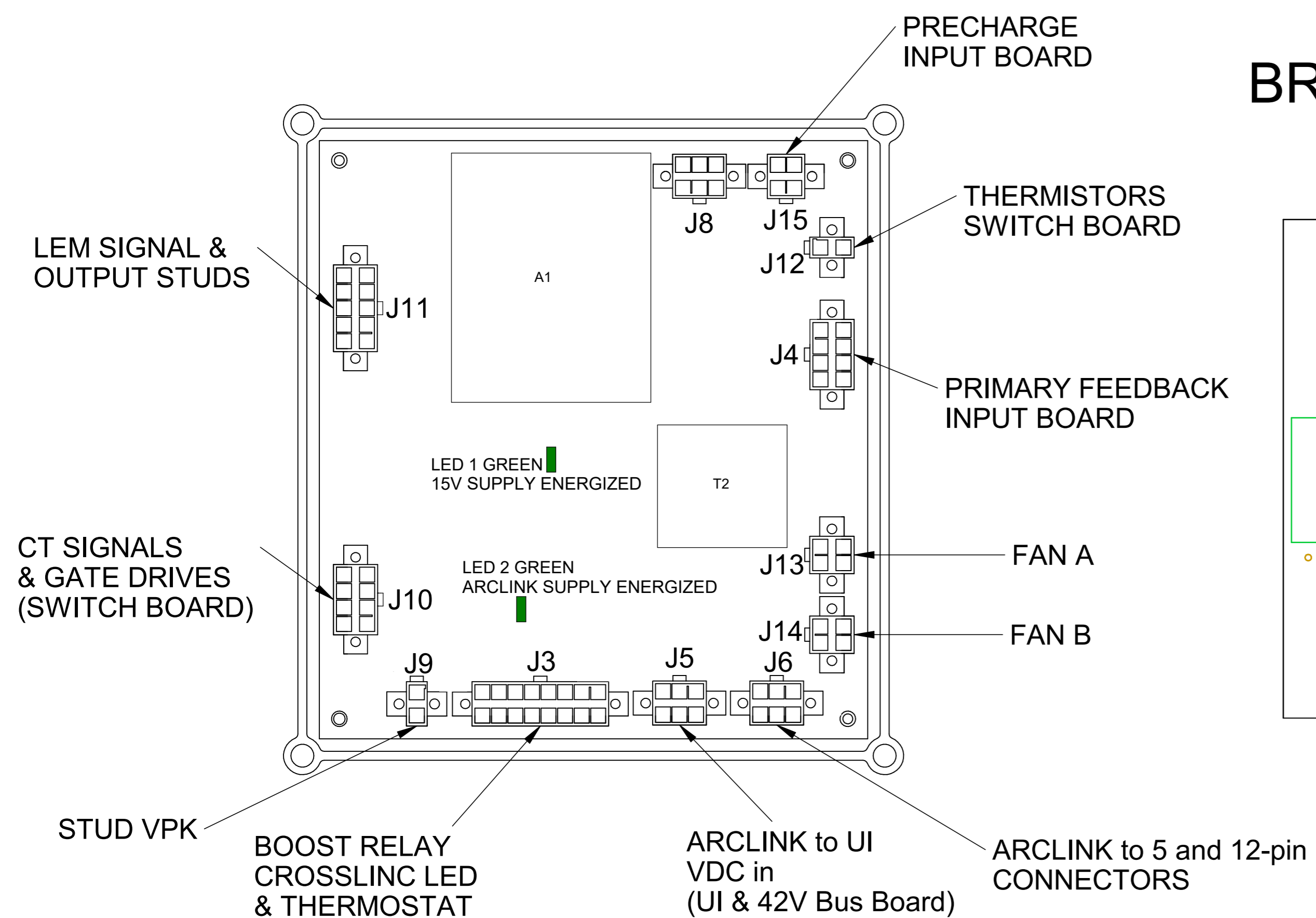

BRAIN BOARD (A1)

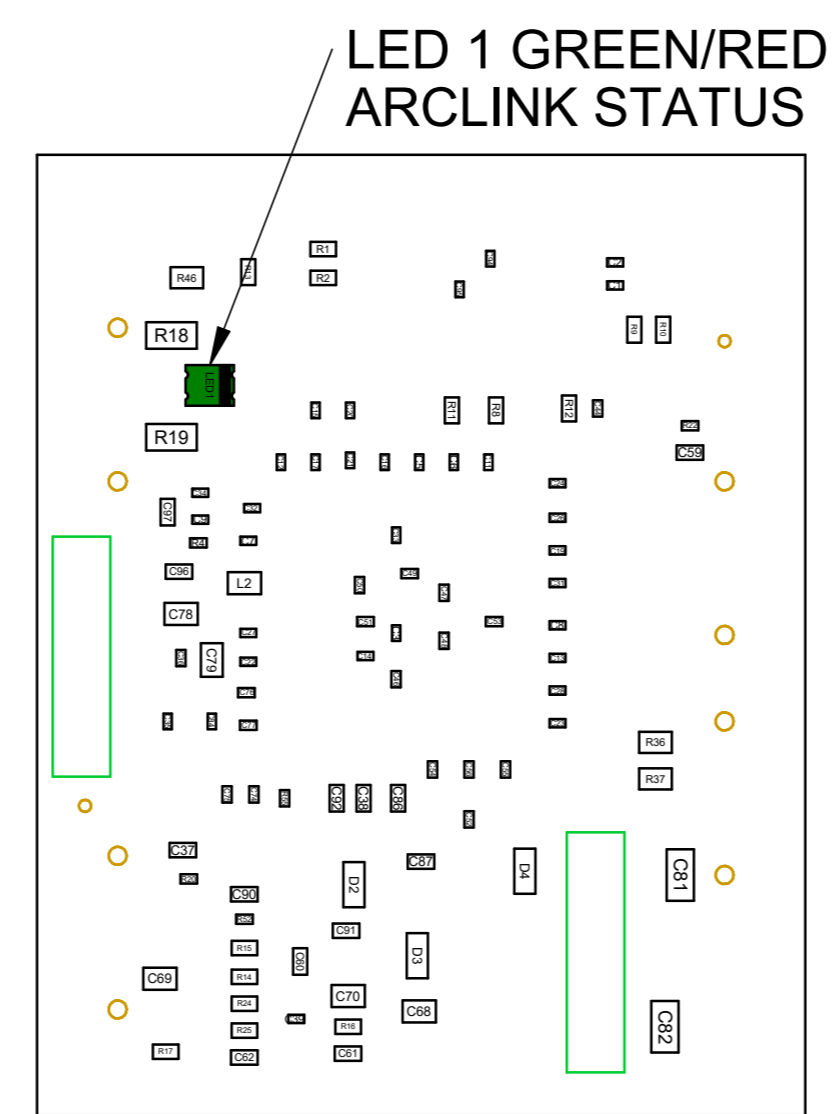

BOOST SNUBBER BOARD

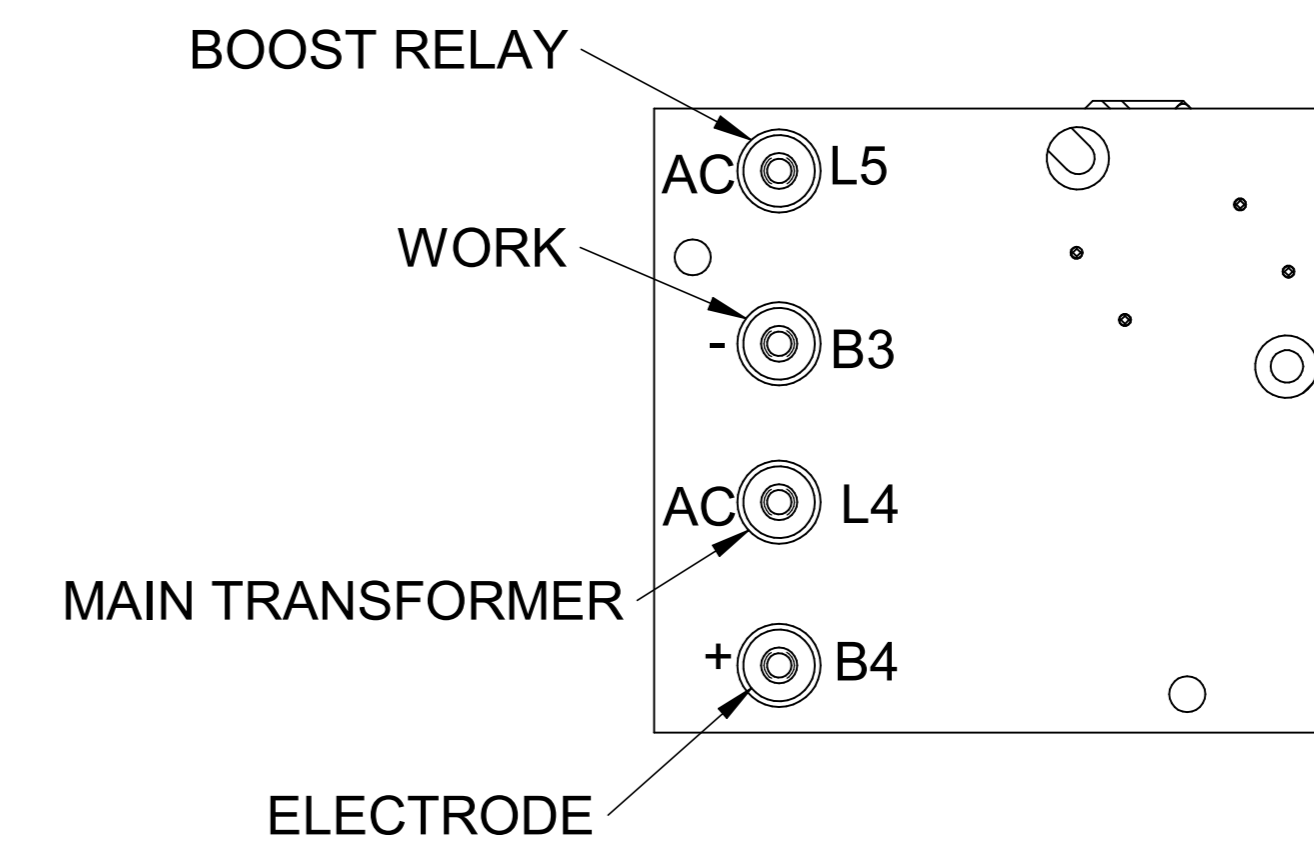

42V DC BUS BOARD

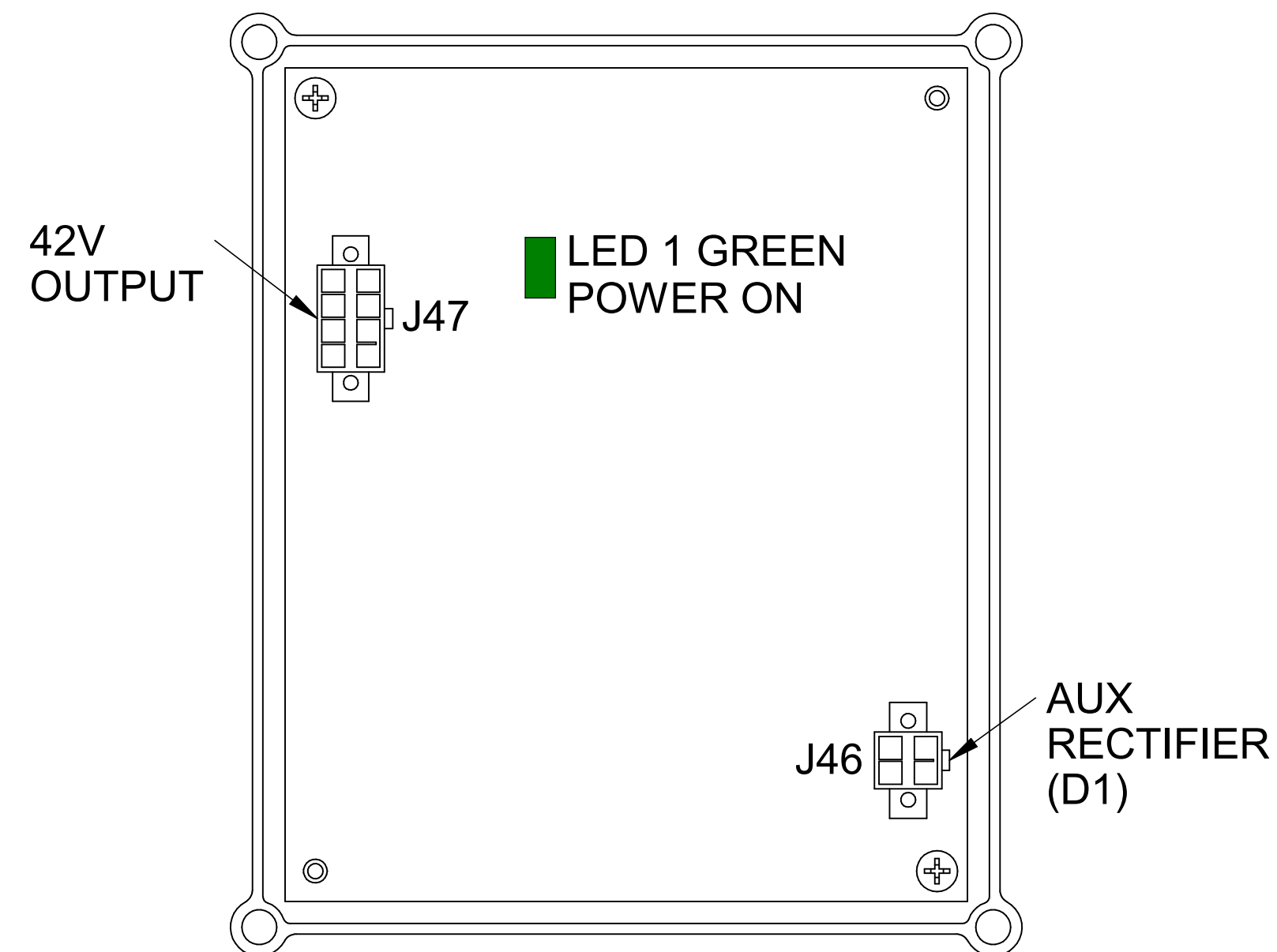

USER INTERFACE BOARD (FRONT)

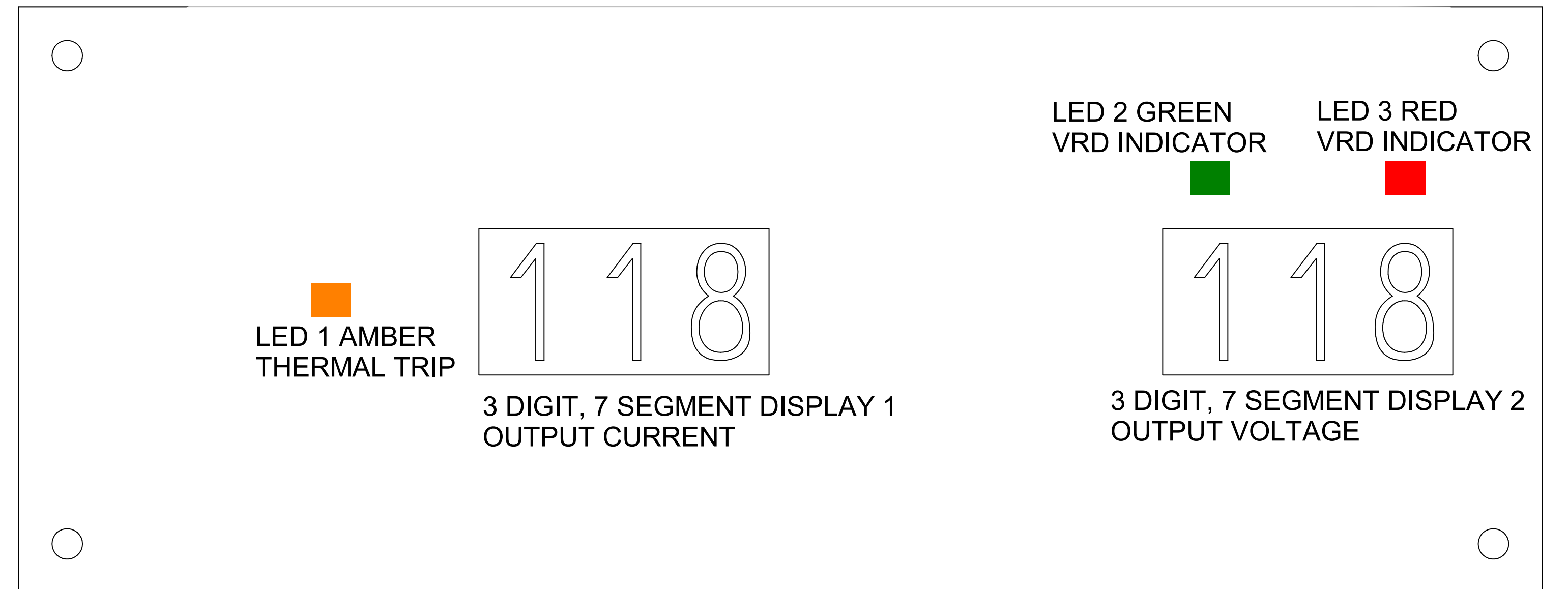

USER INTERFACE BOARD (BACK)

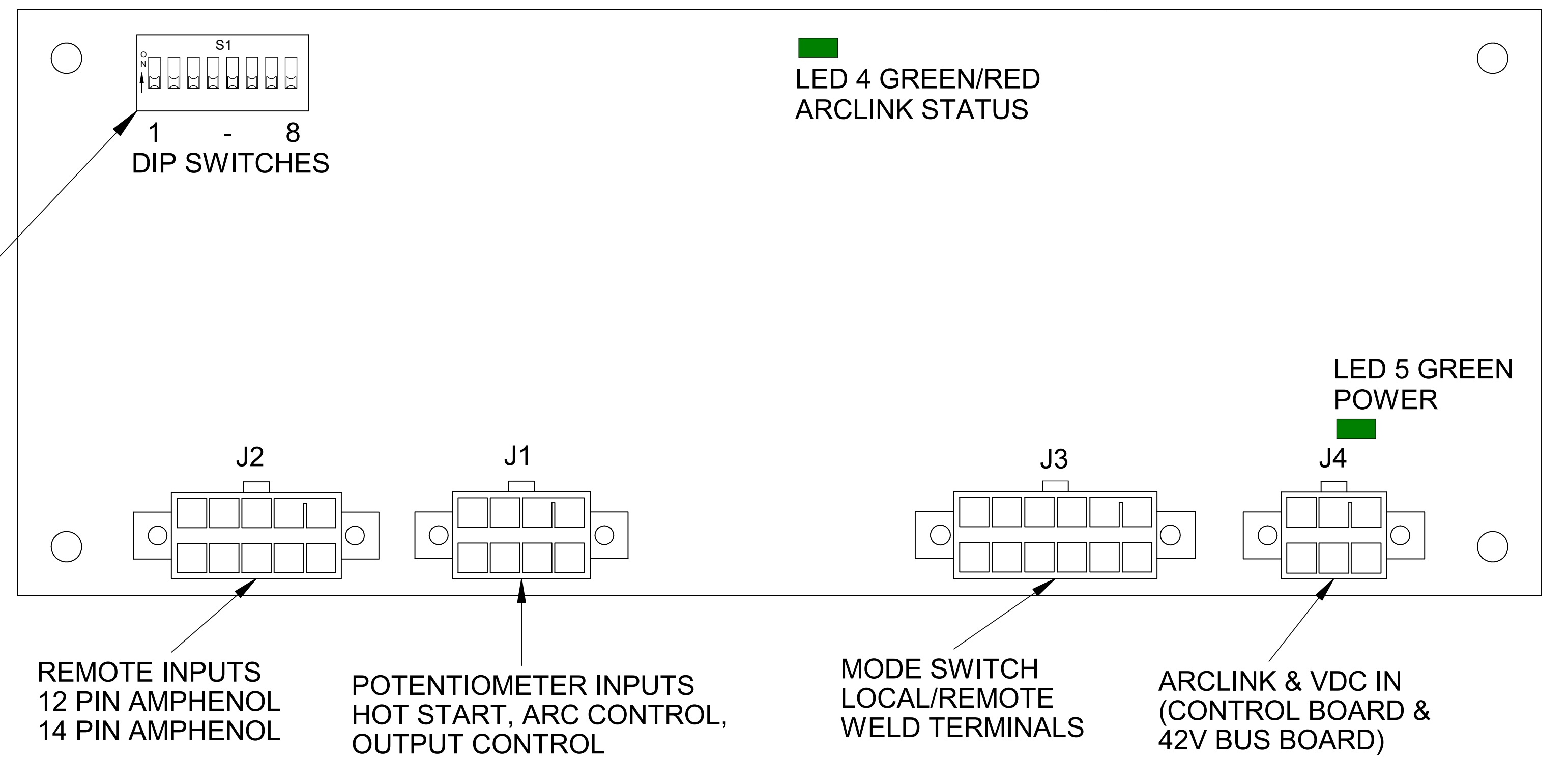

DIP SWITCH FUNCTIONS

SWITCH	FUNCTION	DEFAULT
1	CALIBRATION MODE	OFF
2	NOT USED	OFF
3	NOT USED	OFF
4	CC (MODE 200) & CV (MODE 201) TEST MODES	OFF
5	VRD	OFF
6	NOT USED	OFF
7	NOT USED	OFF
8	FRONT PANEL CHECK, SOFTWARE VERSION, & ERROR LOGS	OFF