

# FLEXTEC 350XP CONSTRUCTION / FX360XL WIRING DIAGRAM G8141-12 REV: C

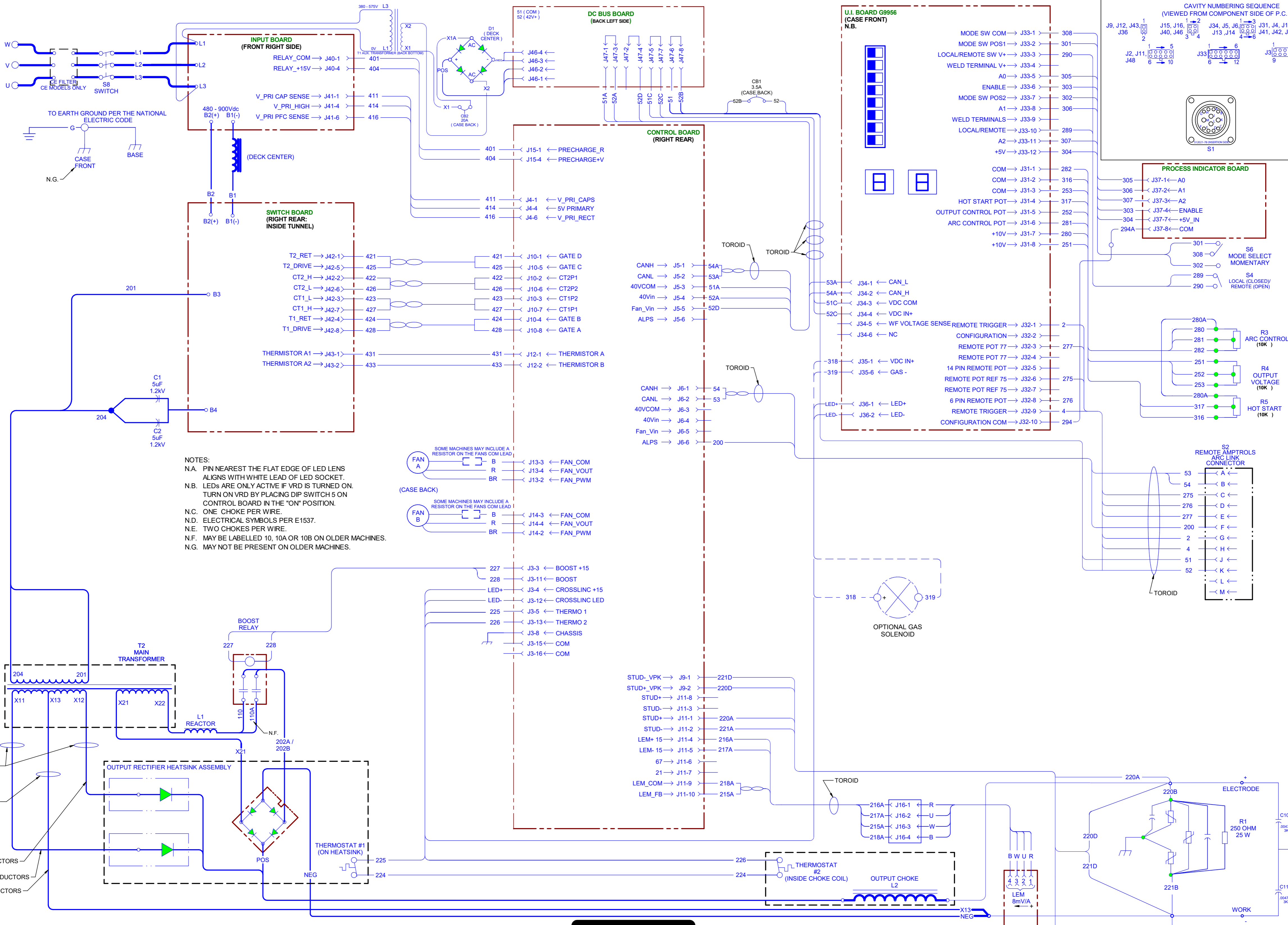

**NOTES:**  
 N.A. PIN NEAREST THE FLAT EDGE OF LED LENS ALIGNS WITH WHITE LEAD OF LED SOCKET.  
 N.B. LEDs ARE ONLY ACTIVE IF VRD IS TURNED ON. TURN ON VRD BY PLACING DIP SWITCH 5 ON CONTROL BOARD IN THE "ON" POSITION.  
 N.C. ONE CHOKE PER WIRE.  
 N.D. ELECTRICAL SYMBOLS PER E1537.  
 N.E. TWO CHOKES PER WIRE.  
 N.F. MAY BE LABELLED 10, 10A OR 10B ON OLDER MACHINES.  
 N.G. MAY NOT BE PRESENT ON OLDER MACHINES.

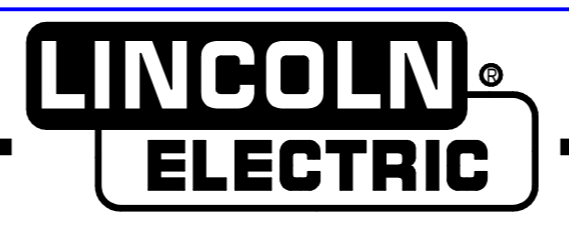
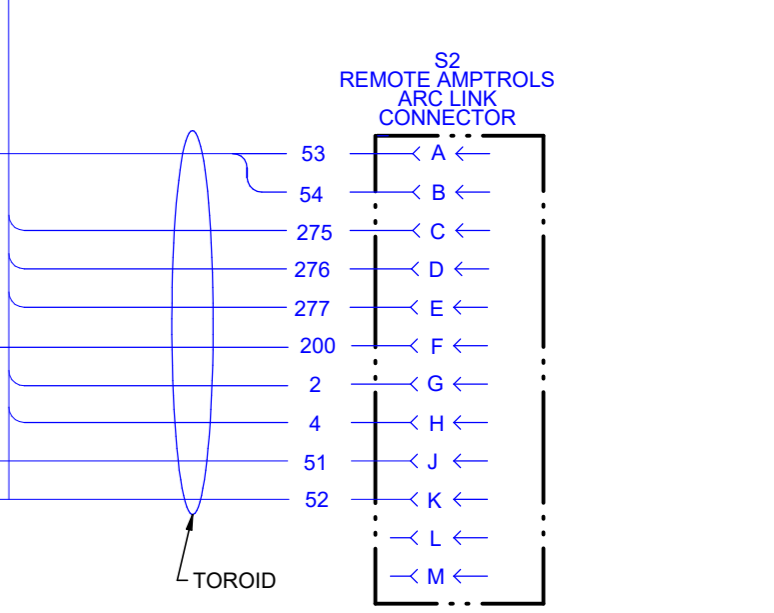
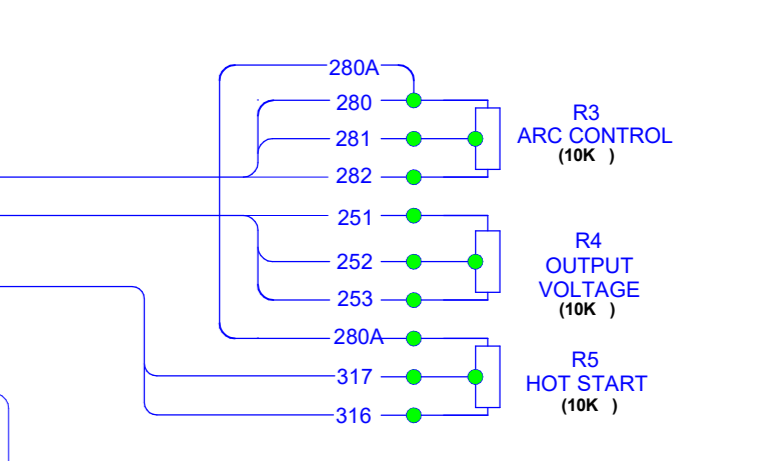
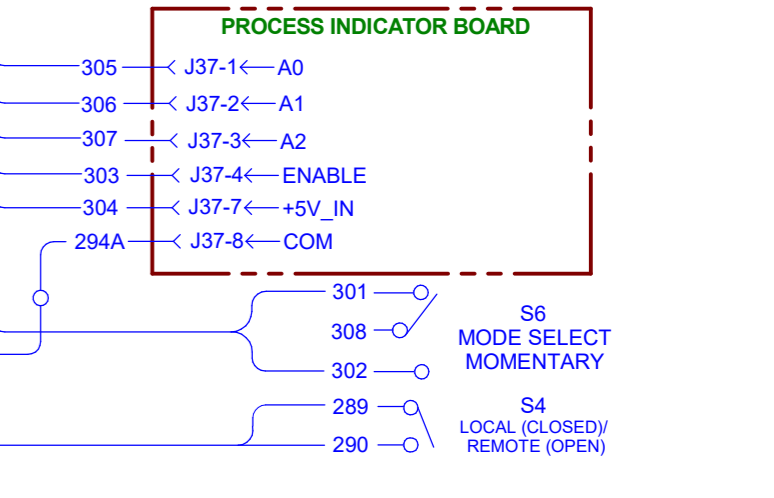
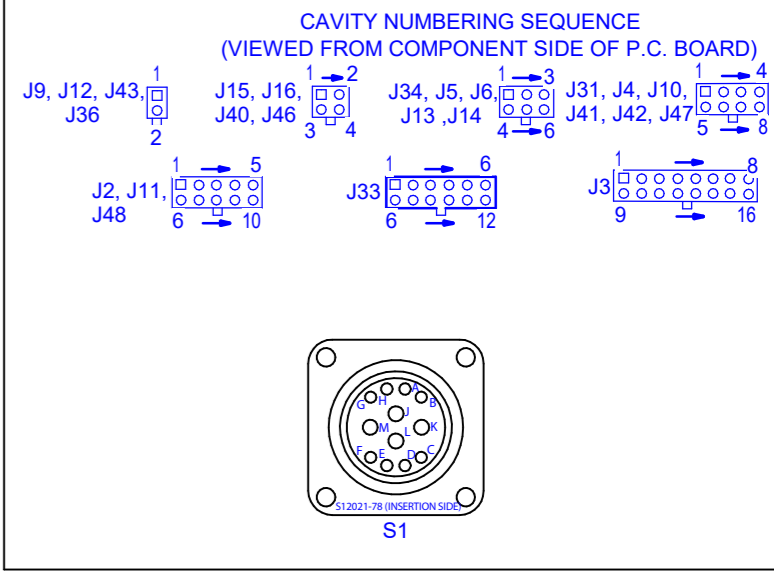

### SWITCHBOARD

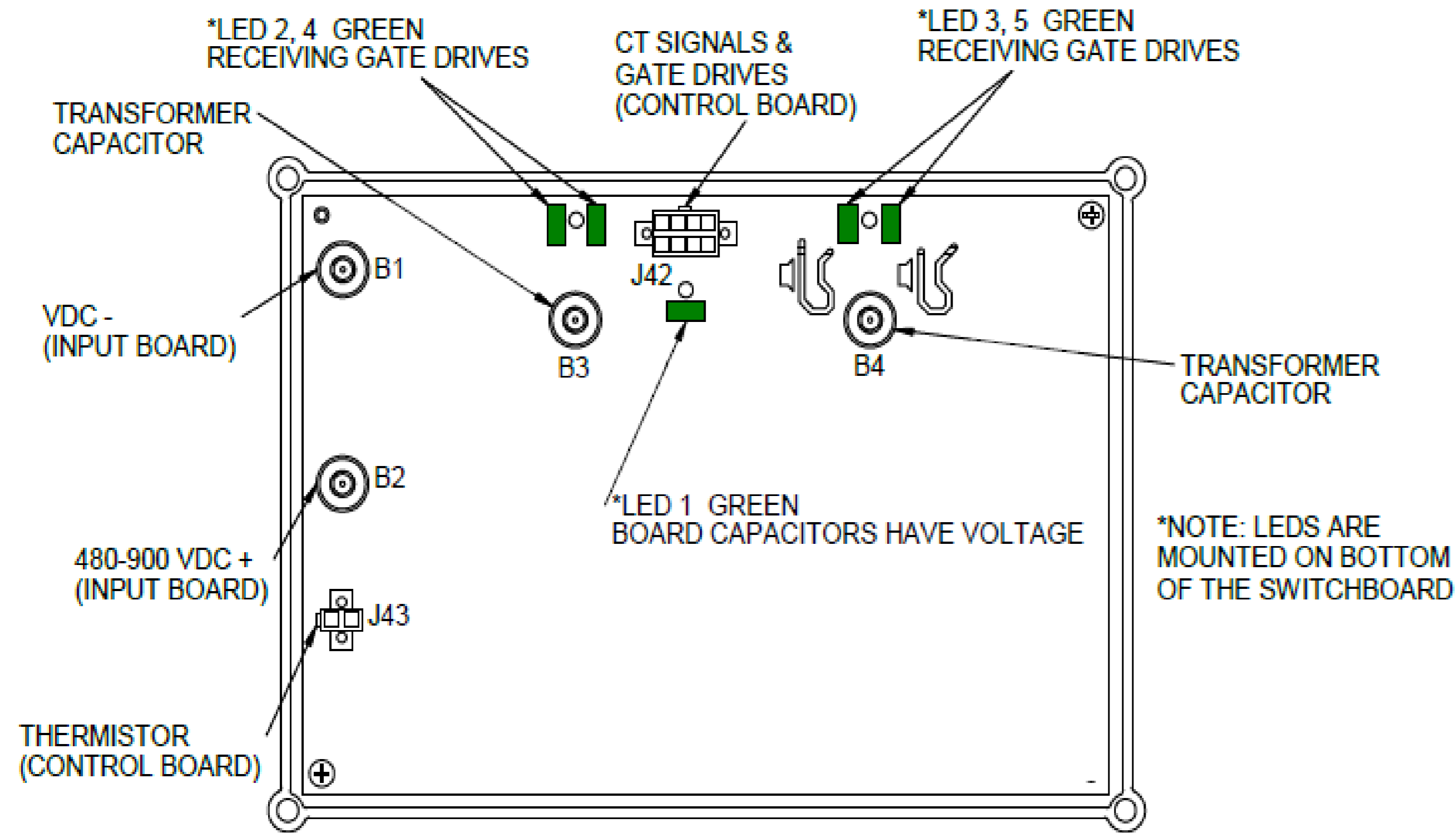

### INPUT P.C. BOARD

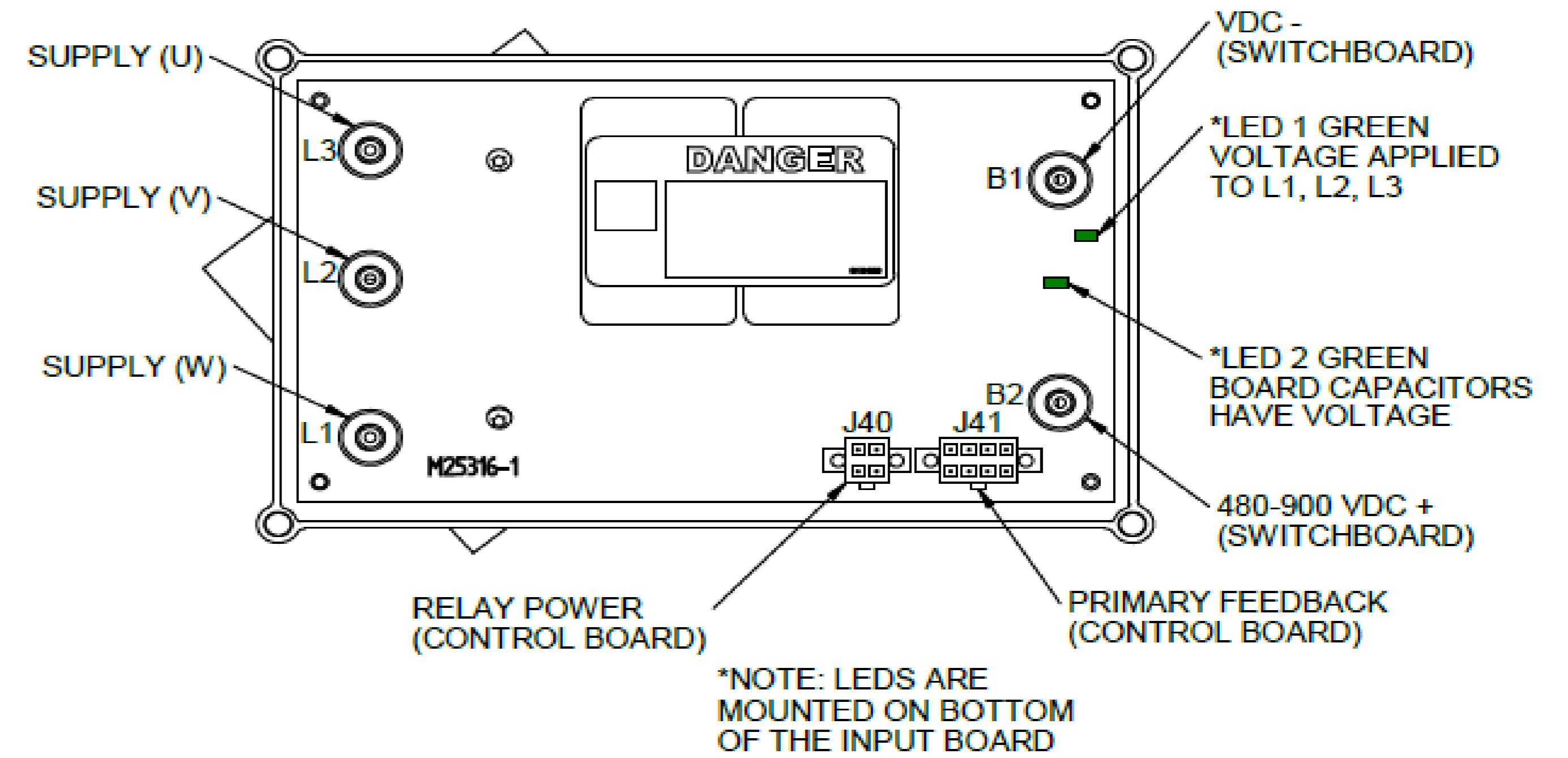

### CONTROL BOARD

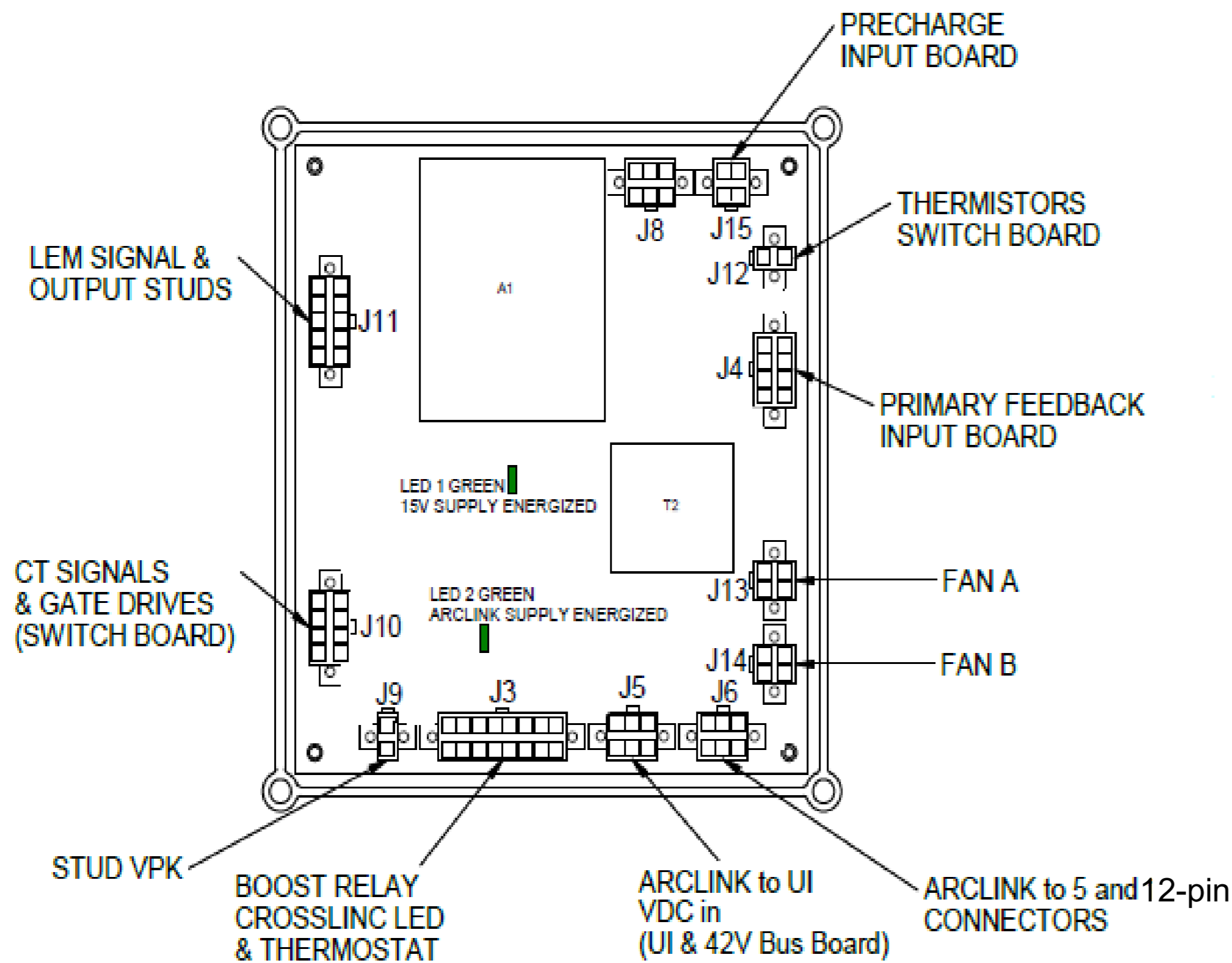

### BRAIN BOARD (A1)

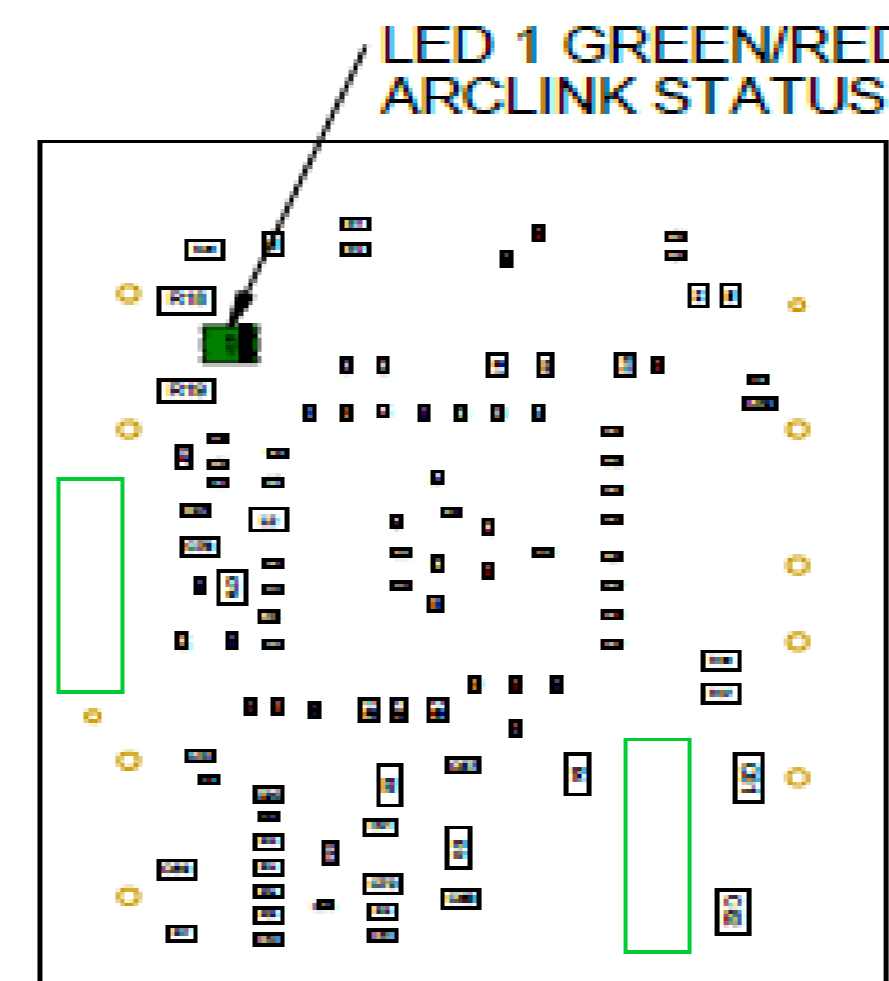

2:1

### 42V DC BUS BOARD

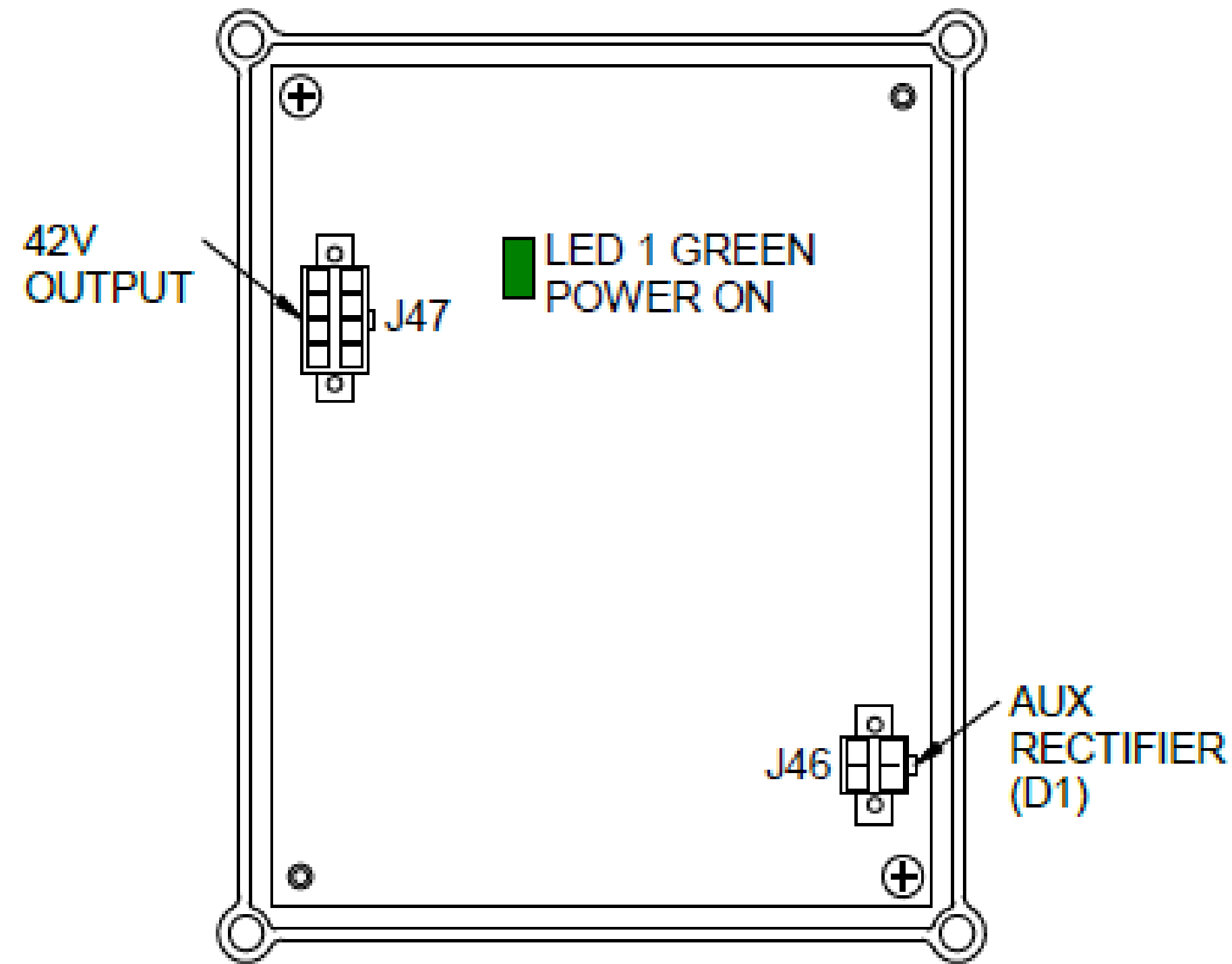

### USER INTERFACE BOARD (FRONT)

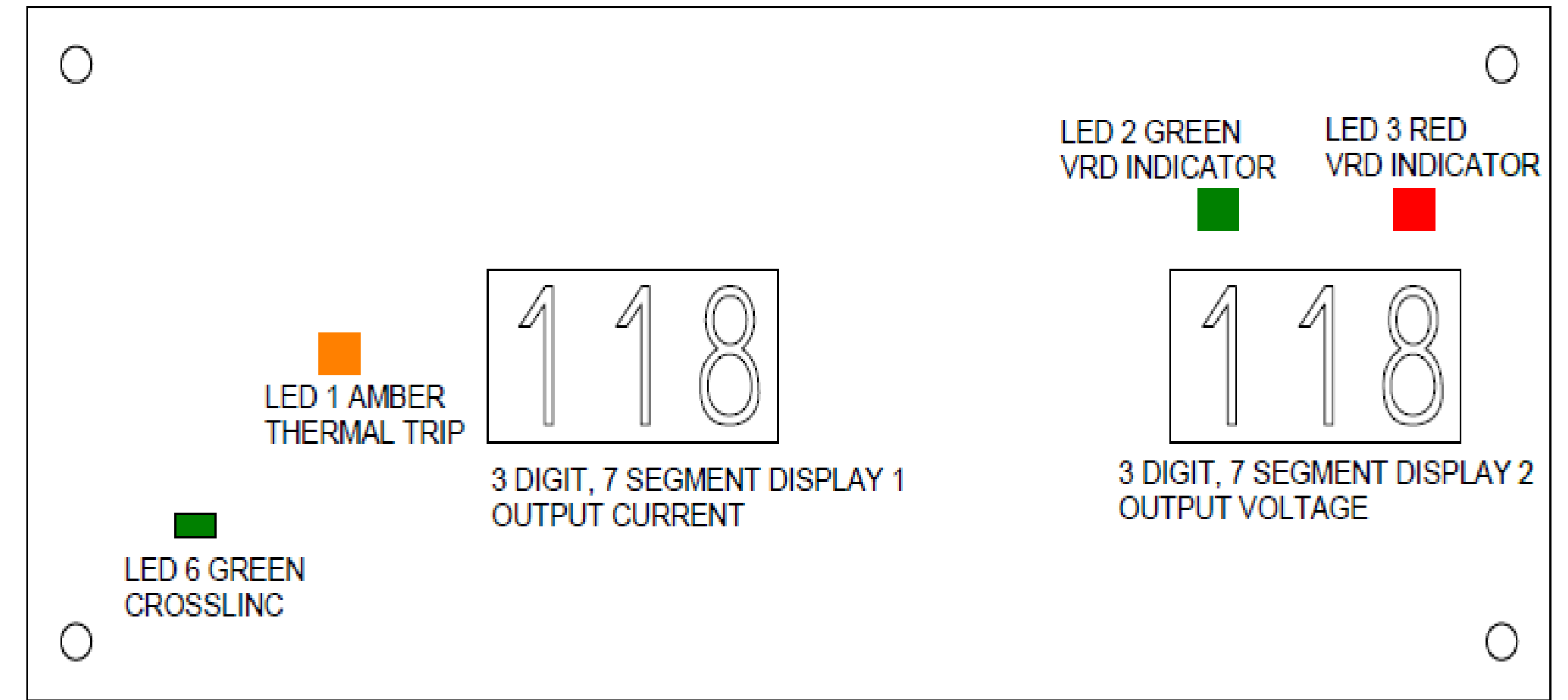

### USER INTERFACE BOARD (BACK)

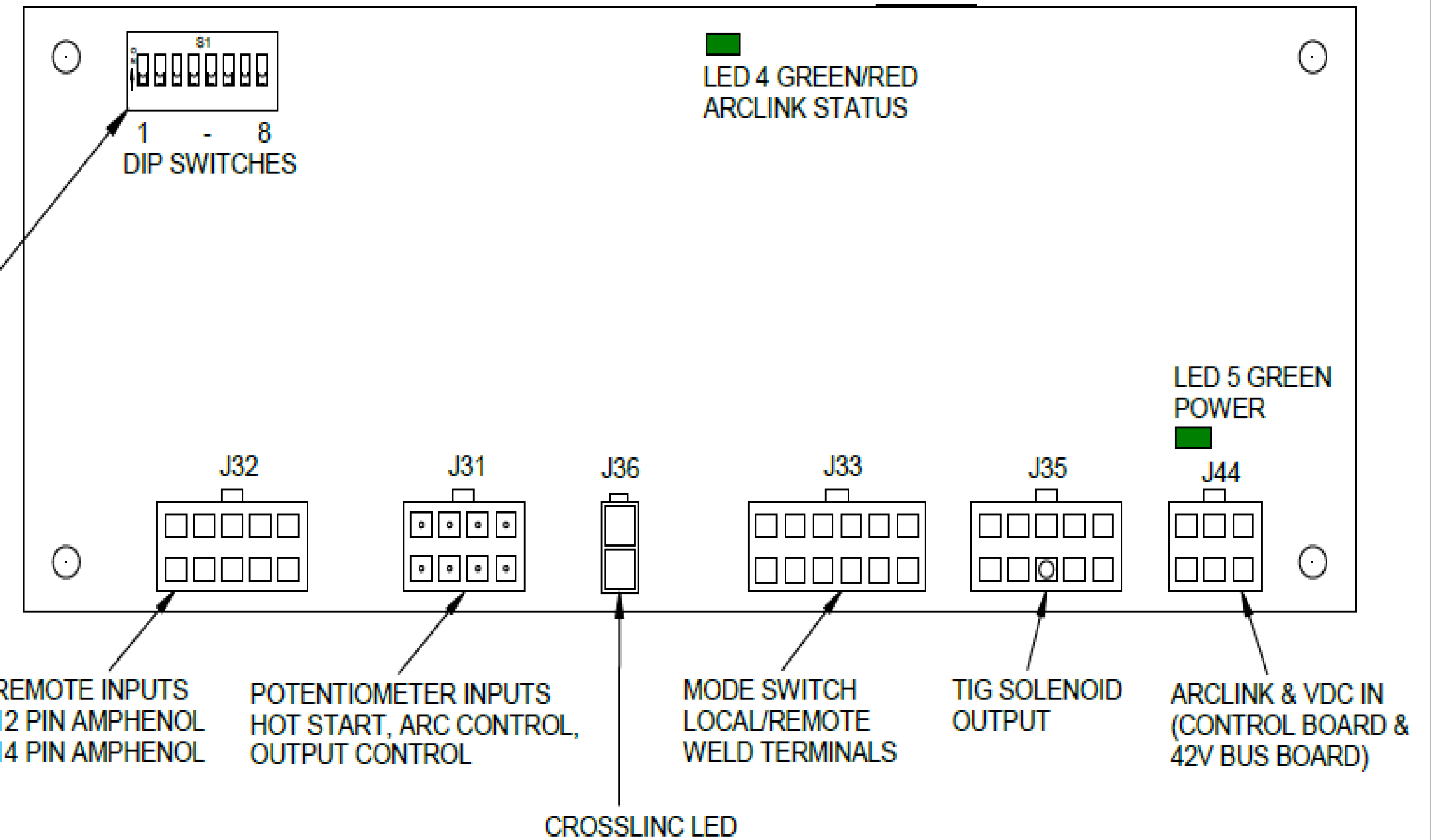

### DIP SWITCH FUNCTIONS

SWITCH	FUNCTION	DEFAULT
1	CALIBRATION MODE	OFF
2	NOT USED	OFF
3	NOT USED	OFF
4	CC (MODE 200) & CV (MODE 201) TEST MODES	OFF
5	VRD	OFF
6	NOT USED	OFF
7	NOT USED	OFF
8	FRONT PANEL CHECK, SOFTWARE VERSION, & ERROR LOGS	OFF