

IM3132
05/2023
REV03

POWERTEC® i400S

OPERATOR'S MANUAL



ENGLISH



Lincoln Electric Bester Sp. z o.o.
ul. Jana III Sobieskiego 19A, 58-260 Bielawa, Poland
www.lincolnelectric.eu



THANKS! For having chosen the QUALITY of the Lincoln Electric products.

- Please Examine Package and Equipment for Damage. Claims for material damaged in shipment must be notified immediately to the dealer.
- For future reference record in the table below your equipment identification information. Model Name, Code & Serial Number can be found on the machine rating plate.

Model Name:	
.....	
Code & Serial number:	
.....
Date & Where Purchased:	
.....

ENGLISH INDEX

Technical Specifications.....	1
ECO design information.....	2
Electromagnetic Compatibility (EMC).....	4
Safety.....	5
Intoduction.....	7
Installation and Operator Instructions.....	7
WEEE.....	11
Spare Parts.....	11
Authorized Service Shops Location.....	11
Electrical Schematic.....	11
Accessories Suggested.....	12
Connection Diagram.....	13
Dimension Diagram.....	14

Technical Specifications

NAME		INDEX		
POWERTEC® i400S		K14241-1		
INPUT				
Input Voltage U ₁	EMC Class		Frequency	
400V ± 15% 3-phase	A		50/60Hz	
Input Power at Rated Cycle	Input Amperes I _{1max}		PF	
15 kVA @ 50% Duty Cycle (40°C)	21A		0,90	
RATED OUTPUT				
Open Circuit Voltage		Duty Cycle 40°C (based on a 10 min. period)	Output Current	Output Voltage
U _{0peak} = 54Vdc U _{0rms} = 54Vdc	GMAW	50%	350A	31,5Vdc
		60%	340A	31,0Vdc
		100%	300A	29,0Vdc
	FCAW	50%	350A	31,5Vdc
		60%	340A	31,0Vdc
		100%	300A	29,0Vdc
	SMAW	30%	350A	34,0Vdc
		60%	320A	32,8Vdc
		100%	275A	31,0Vdc
WELDING CURRENT RANGE				
GMAW	FCAW		SMAW	
20A÷350A	20A÷350A		10A÷350A	
WELDING VOLTAGE REGULATION RANGE				
GMAW		FCAW		
15V÷ 33,5V		15V÷ 33,5V		
RECOMMENDED INPUT CABLE AND FUSE SIZES				
Fuse Type: Time-Delay or Circuit Breaker Type D		Power Lead		
400V				
25A		4 Conductor, 2,5mm ²		
DIMENSION				
Weight	Height	Width	Length	
68kg	932 mm	560 mm	925 mm	
OTHERS				
Protection Rating	Operating Humidity (t=20°C)	Operating Temperature	Storage Temperature	
IP23	≤ 90 %	from -10 °C to +40 °C	from -25 °C to +55 °C	

ECO design information

The equipment has been designed in order to be compliant with the Directive 2009/125/EC and the Regulation 2019/1784/EU.

Efficiency and idle power consumption:

Index	Name	Efficiency when max power consumption / Idle power consumption	Equivalent model
K14241-1	POWERTEC® i400S	86,7% / 29W	No equivalent model

Idle state occurs under the condition specified in below table

IDLE STATE	
Condition	Presence
MIG mode	X
TIG mode	
STICK mode	
After 30 minutes of non-working	
Fan off	X

The value of efficiency and consumption in idle state have been measured by method and conditions defined in the product standard EN 60974-1:20XX.

Manufacturer's name, product name, code number, product number, serial number and date of production can be read from rating plate.

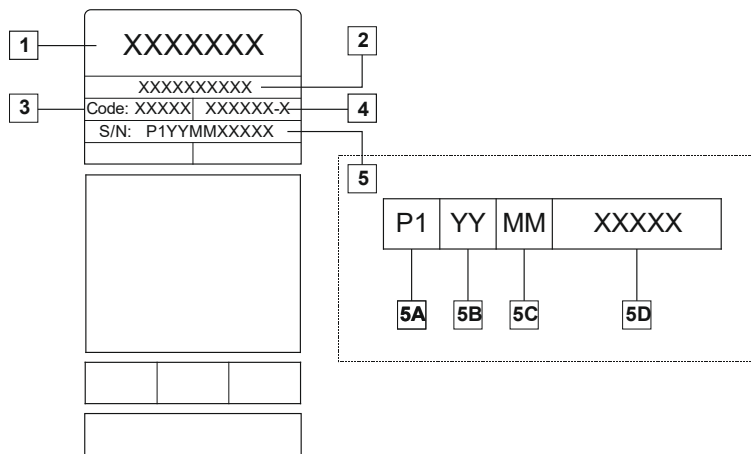

Where:

- 1- Manufacturer name and address
- 2- Product name
- 3- Code number
- 4- Product number
- 5- Serial number
 - 5A- country of production
 - 5B- year of production
 - 5C- month of production
 - 5D- progressive number different for each machine

Typical gas usage for **MIG/MAG** equipment:

Material type	Wire diameter [mm]	DC electrode positive		Wire Feeding [m/min]	Shielding Gas	Gas flow [l/min]
		Current [A]	Voltage [V]			
Carbon, low alloy steel	0,9 ÷ 1,1	95 ÷ 200	18 ÷ 22	3,5 – 6,5	Ar 75%, CO ₂ 25%	12
Aluminium	0,8 ÷ 1,6	90 ÷ 240	18 ÷ 26	5,5 – 9,5	Argon	14 ÷ 19
Austenitic stainless steel	0,8 ÷ 1,6	85 ÷ 300	21 ÷ 28	3 - 7	Ar 98%, O ₂ 2% / He 90%, Ar 7,5% CO ₂ 2,5%	14 ÷ 16
Copper alloy	0,9 ÷ 1,6	175 ÷ 385	23 ÷ 26	6 - 11	Argon	12 ÷ 16
Magnesium	1,6 ÷ 2,4	70 ÷ 335	16 ÷ 26	4 - 15	Argon	24 ÷ 28

Tig Process:

In TIG welding process, gas usage depends on cross-sectional area of the nozzle. For commonly used torches:

Helium: 14-24 l/min.

Argon: 7-16 l/min.

Notice: Excessive flow rates causes turbulence in the gas stream which may aspirate atmospheric contamination into the welding pool.

Notice: A cross wind or draft moving can disrupt the shielding gas coverage, in the interest of saving of protective gas use screen to block air flow.



End of life

At end of life of product, it has to be disposal for recycling in accordance with Directive 2012/19/EU (WEEE), information about the dismantling of product and Critical Raw Material (CRM) present in the product, can be found at <https://www.lincolnelectric.com/en-gb/support/Pages/operator-manuals-eu.aspx>.

Electromagnetic Compatibility (EMC)

01/11

This machine has been designed in accordance with all relevant directives and standards. However, it may still generate electromagnetic disturbances that can affect other systems like telecommunications (telephone, radio, and television) or other safety systems. These disturbances can cause safety problems in the affected systems. Read and understand this section to eliminate or reduce the amount of electromagnetic disturbance generated by this machine.



This machine has been designed to operate in an industrial area. The operator must install and operate this equipment as described in this manual. If any electromagnetic disturbances are detected the operator must put in place corrective actions to eliminate these disturbances with, if necessary, assistance from Lincoln Electric.

WARNING

Provided that the public low voltage system impedance at the point of common coupling is lower than:

- 105 mΩ for the **POWERTEC® i400S**

This equipment is compliant with IEC 61000-3-11 and IEC 61000-3-12 and can be connected to public lowvoltage systems. It is the responsibility of the installer or user of the equipment to ensure, by consultation with the distribution network operator if necessary, that the system impedance complies with the impedance restrictions.

Before installing the machine, the operator must check the work area for any devices that may malfunction because of electromagnetic disturbances. Consider the following.

- Input and output cables, control cables, and telephone cables that are in or adjacent to the work area and the machine.
- Radio and/or television transmitters and receivers. Computers or computer controlled equipment.
- Safety and control equipment for industrial processes. Equipment for calibration and measurement.
- Personal medical devices like pacemakers and hearing aids.
- Check the electromagnetic immunity for equipment operating in or near the work area. The operator must be sure that all equipment in the area is compatible. This may require additional protection measures.
- The dimensions of the work area to consider will depend on the construction of the area and other activities that are taking place.

Consider the following guidelines to reduce electromagnetic emissions from the machine.

- Connect the machine to the input supply according to this manual. If disturbances occur it may be necessary to take additional precautions such as filtering the input supply.
- The output cables should be kept as short as possible and should be positioned together. If possible connect the work piece to ground in order to reduce the electromagnetic emissions. The operator must check that connecting the work piece to ground does not cause problems or unsafe operating conditions for personnel and equipment.
- Shielding of cables in the work area can reduce electromagnetic emissions. This may be necessary for special applications.

WARNING











The Class A equipment is not intended for use in residential locations where the electrical power is provided by the public low-voltage supply system. There can be potential difficulties in ensuring electromagnetic compatibility in those locations, due to conducted as well as radio-frequency disturbances.







WARNING

This equipment must be used by qualified personnel. Be sure that all installation, operation, maintenance and repair procedures are performed only by qualified person. Read and understand this manual before operating this equipment. Failure to follow the instructions in this manual could cause serious personal injury, loss of life, or damage to this equipment. Read and understand the following explanations of the warning symbols. Lincoln Electric is not responsible for damages caused by improper installation, improper care or abnormal operation.

	<p>WARNING: This symbol indicates that instructions must be followed to avoid serious personal injury, loss of life, or damage to this equipment. Protect yourself and others from possible serious injury or death.</p>
	<p>READ AND UNDERSTAND INSTRUCTIONS: Read and understand this manual before operating this equipment. Arc welding can be hazardous. Failure to follow the instructions in this manual could cause serious personal injury, loss of life, or damage to this equipment.</p>
	<p>ELECTRIC SHOCK CAN KILL: Welding equipment generates high voltages. Do not touch the electrode, work clamp, or connected work pieces when this equipment is on. Insulate yourself from the electrode, work clamp and connected work pieces.</p>
	<p>ELECTRICALLY POWERED EQUIPMENT: Turn off input power using the disconnect switch at the fuse box before working on this equipment. Ground this equipment in accordance with local electrical regulations.</p>
	<p>ELECTRICALLY POWERED EQUIPMENT: Regularly inspect the input, electrode, and work clamp cables. If any insulation damage exists replace the cable immediately. Do not place the electrode holder directly on the welding table or any other surface in contact with the work clamp to avoid the risk of accidental arc ignition.</p>
	<p>ELECTRIC AND MAGNETIC FIELDS MAY BE DANGEROUS: Electric current flowing through any conductor creates electric and magnetic fields (EMF). EMF fields may interfere with some pacemakers and welders having a pacemaker shall consult their physician before operating this equipment.</p>
	<p>CE COMPLIANCE: This equipment complies with the European Community Directives.</p>
	<p>ARTIFICIAL OPTICAL RADIATION: According with the requirements in 2006/25/EC Directive and EN 12198 Standard, the equipment is a category 2. It makes mandatory the adoption of Personal Protective Equipment (PPE) having filter with a protection degree up to a maximum of 15, as required by EN169 Standard.</p>
	<p>FUMES AND GASES CAN BE DANGEROUS: Welding may produce fumes and gases hazardous to health. Avoid breathing these fumes and gases. To avoid these dangers the operator must use enough ventilation or exhaust to keep fumes and gases away from the breathing zone.</p>
	<p>ARC RAYS CAN BURN: Use a shield with the proper filter and cover plates to protect your eyes from sparks and the rays of the arc when welding or observing. Use suitable clothing made from durable flame-resistant material to protect you skin and that of your helpers. Protect other nearby personnel with suitable, non-flammable screening and warn them not to watch the arc nor expose themselves to the arc.</p>
	<p>WELDING SPARKS CAN CAUSE FIRE OR EXPLOSION: Remove fire hazards from the welding area and have a fire extinguisher readily available. Welding sparks and hot materials from the welding process can easily go through small cracks and openings to adjacent areas. Do not weld on any tanks, drums, containers, or material until the proper steps have been taken to insure that no flammable or toxic vapors will be present. Never operate this equipment when flammable gases, vapors or liquid combustibles are present.</p>
	<p>WELDED MATERIALS CAN BURN: Welding generates a large amount of heat. Hot surfaces and materials in work area can cause serious burns. Use gloves and pliers when touching or moving materials in the work area.</p>

	<p>CYLINDER MAY EXPLODE IF DAMAGED: Use only compressed gas cylinders containing the correct shielding gas for the process used and properly operating regulators designed for the gas and pressure used. Always keep cylinders in an upright position securely chained to a fixed support. Do not move or transport gas cylinders with the protection cap removed. Do not allow the electrode, electrode holder, work clamp or any other electrically live part to touch a gas cylinder. Gas cylinders must be located away from areas where they may be subjected to physical damage or the welding process including sparks and heat sources.</p>
	<p>SAFETY MARK: This equipment is suitable for supplying power for welding operations carried out in an environment with increased hazard of electric shock.</p>

The manufacturer reserves the right to make changes and/or improvements in design without upgrade at the same time the operator's manual.

Introduction

POWERTEC® i400S inverter source have to be connected with wire feeder **LF52Ds**. Signal from the power source will be displayed on wire feeders user interface. For communication, inverter source-wire feeder is used CAN protocol.

Inverter source-wire feed configuration allows the welding:

- GMAW (MIG/MAG);
- FCAW;
- SMAW (MMA).

The complete packaging includes the following items:

- Inverter source;
- USB with Operator's Manual;
- Work lead - 3m;
- Slow-blow fuse – 2A (2 units);
- Gas hose -2m;
- Chain.

Recommended equipment, which can be bought by the user, was mentioned in the chapter "Accessories Suggested".

Installation and Operator Instructions

Read this entire section before installation or operation of the machine.

Location and Environment

This machine can be operate in harsh environment. However, it is important to use simple preventative measures, which provide long life and reliable operation.

- Do not place or operate this machine on a surface with an incline higher than 15° from horizontal.
- Do not use this machine for pipe thawing.
- This machine must be located in a place where there is free circulation of clean air without restrictions for air movement to and from the air vents. Do not cover the machine with paper, cloth or rags when switched on.
- Keep away from dirt and dust that can be drawn into the machine should be kept to a minimum.
- This machine has a protection rating of IP23. Keep it dry when possible and do not place it on a wet ground or in puddles.
- Locate the machine away from radio controlled machinery. Normal operation may adversely affect the operation of nearby radio controlled machinery, which may result in injury or equipment damage. Read the section on electromagnetic compatibility in this manual.
- Do not operate in areas with an ambient temperature higher than 40°C.

Duty cycle and Overheating

The duty cycle of a welding machine is the percentage of time in a 10 minute cycle at which the welder can operate the machine at rated welding current.

Example: 60% duty cycle

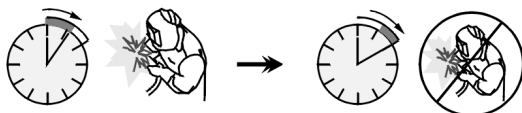

Welding for 6 minutes.

Break for 4 minutes.

Excessive extension of the duty cycle will cause the thermal protection circuit to activate.

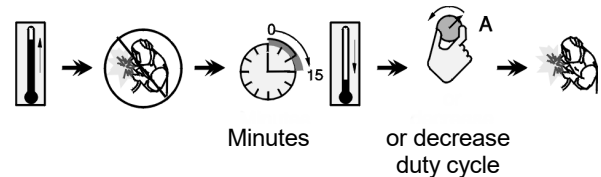

Input Supply Connection

⚠ WARNING

Only a qualified electrician can connect the welding machine to the supply network. Installation the outlet plug to power lead and connecting the welding machine had to be made in accordance with the appropriate National Electrical Code and local regulations.

Check the input voltage, phases, and frequency supplied to this machine before turning it on. Verify the connection of grounding wires from the machine to the input power source. **POWERTEC® i400S** can only be connected to a mating grounded receptacle.

Input voltages is 3x400V 50/60Hz. For more information about input supply please refer to the technical specification section of this manual and to the rating plate of the machine.

Make sure that the amount of mains power available from the input supply is adequate for normal operation of the machine. The type of protection and cable sizes are indicated in the technical specification section of this manual.

⚠ WARNING

The welding machine can be supplied from a power generator of output power at least 30% larger than input power of the welding machine. See "Technical Specifications" chapter.

⚠ WARNING

In case of powering welder from a generator make sure to turn off welding machine first, before generator is shut down, in order to prevent damage to welding machine!

Output Connections

Refer to points [2], [3] and [4] of the figures below.

Controls and Operational Features

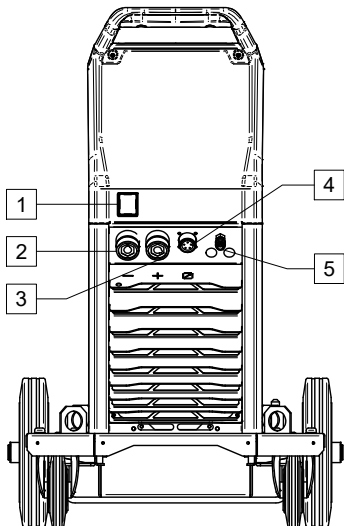

Figure 1.

1. **Power Switch ON/OFF (I/O):** Controls the input power. Make sure the power source is properly connected to the mains supply before turning power on ("I").
2. **Negative Output Socket for the Welding Circuit:** Depending on the configuration of power source, for connecting a work lead, the electrode holder with lead or the source/wire feeder welding cable.
3. **Positive Output Socket for the Welding Circuit:** Depending on the configuration of power source, for connecting a work lead, the electrode holder with lead or the source/wire feeder welding cable.
4. **Control Receptacle:** 5 pins receptacle for wire feeder or remote controller connection. To communication wire feeder or remote controller with power source is used CAN protocol.
5. **Gas Connector:** For connection a gas hose from interconnecting cable.

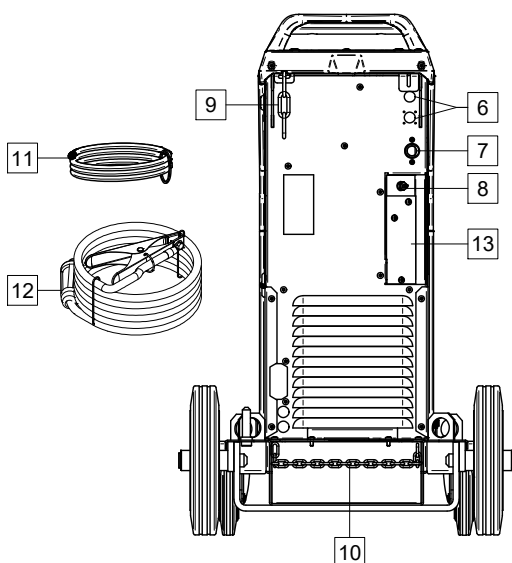

Figure 2.

6. **Supply Plug:** for gas heater kit (see "Accessories Suggested" chapter).
7. **Power Lead (5 m):** Connect the supply plug to the existing input cable that is rated for the machine as indicated in this manual, and conforms to all applicable standards. This connection shall be performed by a qualified person only.
8. **Gas Connector:** For connection a gas hose from cylinder.
9. **Top Chain:** To protect gas bottle.
10. **Bottom chain:** For properly securing the gas cylinder.

WARNING

Not using both chains at the same time to secure the gas cylinder may result in damage to the cylinder, the device and personal injury.

11. **Gas hose:** For connection between the cylinder and machine.
12. **Mass welding cable.**
13. **Cover bracket:** To install the welding and control sockets on the rear panel of the device (see chapter "Accessories Suggested") to connect the wire feeder.

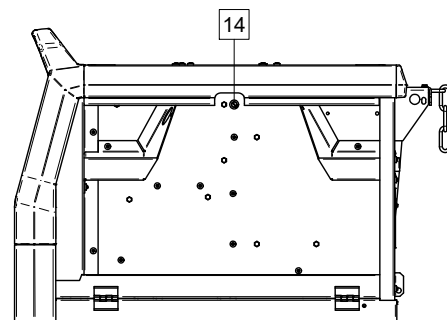

Figure 3.

14. **Fuse F1:** Use the 2A/400V (6,3x32mm) low blow fuse.

Welding Cables Connection

Insert the plug of the work lead into the socket [2]. The other end of this lead connect to the work piece with the work clamp.

Connect the wire feeder to the power source:

- Insert the positive welding cable into the output socket [3].
- Insert the wire feeder control cable into the socket [4] (see "Accessories Suggested" chapter).

Use the possible shortest cable lengths.

Machine and Circuit Protection

Power Source is protected against overheating, overload and accidental short-circuits.

If the machine is overheated, the thermal protection circuit will decrease the output current to 0. This information will be shown by wire feeder user interface. Please refer to wire feeder user manual.

Transport & Lifting

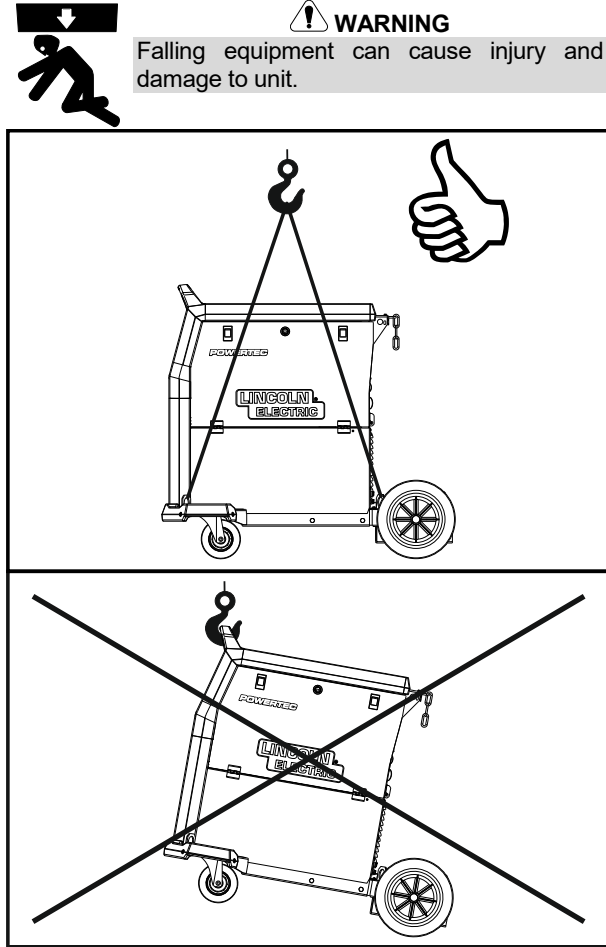

Figure 4.

During transportation and lifting with a crane, adhere to the following rules:

- The device contains elements adapted for transport.
- For lifting a suitable lifting equipment capacity.
- For lifting and transport use minimum four belts.
- Lift and transport only power source without gas cylinder, cooler and wire feeder, or/and any other accessories.

Maintenance

! WARNING

For any repair operations, modifications or maintenances, it is recommended to contact the nearest Technical Service Center or Lincoln Electric. Repairs and modifications performed by unauthorized service or personnel will cause, that the manufacturer's warranty will be lost.

Any noticeable damage should be reported immediately and repaired.

Routine maintenance (everyday)

- Check condition of insulation and connections of the work leads and insulation of power lead. If any insulation damage exists replace the lead immediately.
- Remove the spatters from the welding gun nozzle. Spatters could interfere with the shielding gas flow to the arc.
- Check the welding gun condition: replace it, if necessary.
- Check condition and operation of the cooling fan. Keep clean its airflow slots.

Periodic maintenance (every 200 working hours, but at list once a year)

Perform the routine maintenance and, in addition:

- Keep the machine clean. Using a dry (and low pressure) airflow, remove the dust from the external case and from the cabinet inside.
- If it is required, clean and tighten all weld terminals.

The frequency of the maintenance operations may vary according to the working environment where the machine is placed.

! WARNING

Do not touch electrically live parts.

! WARNING

Before the case of welding machine will be removed, the welding machine has to be turned off and the power lead had to be disconnected from mains socket.

! WARNING

Mains supply network must be disconnected from the machine before each maintenance and service. After each repair, perform proper tests to ensure safety.

Customer Assistance Policy

The business of The Lincoln Electric Company is manufacturing and selling high quality welding equipment, consumables, and cutting equipment. Our challenge is to meet the needs of our customers and to exceed their expectations. On occasion, purchasers may ask Lincoln Electric for advice or information about their use of our products. We respond to our customers based on the best information in our possession at that time. Lincoln Electric is not in a position to warrant or guarantee such advice, and assumes no liability, with respect to such information or advice. We expressly disclaim any warranty of any kind, including any warranty of fitness for any customer's particular purpose, with respect to such information or advice. As a matter of practical consideration, we also cannot assume any responsibility for updating or correcting any such information or advice once it has been given, nor does the provision of information or advice create, expand or alter any warranty with respect to the sale of our products.

Lincoln Electric is a responsive manufacturer, but the selection and use of specific products sold by Lincoln Electric is solely within the control of, and remains the sole responsibility of the customer. Many variables beyond the control of Lincoln Electric affect the results obtained in applying these types of fabrication methods and service requirements.

Subject to Change – This information is accurate to the best of our knowledge at the time of printing. Please refer to www.lincolnelectric.com for any updated information.

WEEE

07/06



Do not dispose of electrical equipment together with normal waste!

In observance of European Directive 2012/19/EC on Waste Electrical and Electronic Equipment (WEEE) and its implementation in accordance with national law, electrical equipment that has reached the end of its life must be collected separately and returned to an environmentally compatible recycling facility. As the owner of the equipment, you should get information on approved collection systems from our local representative.

By applying this European Directive you will protect the environment and human health!

Spare Parts

12/05

Part List reading instructions

- Do not use this part list for a machine if its code number is not listed. Contact the Lincoln Electric Service Department for any code number not listed.
- Use the illustration of assembly page and the table below to determine where the part is located for your particular code machine.
- Use only the parts marked "X" in the column under the heading number called for in the assembly page (# indicate a change in this printing).

First, read the Part List reading instructions above, then refer to the "Spare Part" manual supplied with the machine, that contains a picture-descriptive part number cross-reference.

Authorized Service Shops Location

09/16

- The purchaser must contact a Lincoln Authorized Service Facility (LASF) about any defect claimed under Lincoln's warranty period.
- Contact your local Lincoln Sales Representative for assistance in locating a LASF or go to www.lincolnelectric.com/en-gb/Support/Locator.

Electrical Schematic

Refer to the "Spare Part" manual supplied with the machine.

Accessories Suggested

K14186-2	LF 52Ds
GRD-400A-70-xM*	Ground cable 400A/70 mm ² ; x=5/10/15 m
K14196-1	OUTPUT CONNECTION KIT
K14201-1	CABLE MANAGEMENT KIT
K14176-1	GAS HEATER KIT (POWERTEC®-i)
INTERCONNECTION CABLE	
K14198-PG-30M-S	CABLE PACK 5PIN G 95MM2 30M (SHIPYARD)
K14198-PG-40M-S	CABLE PACK 5PIN G 95MM2 40M (SHIPYARD)

Connection Diagram

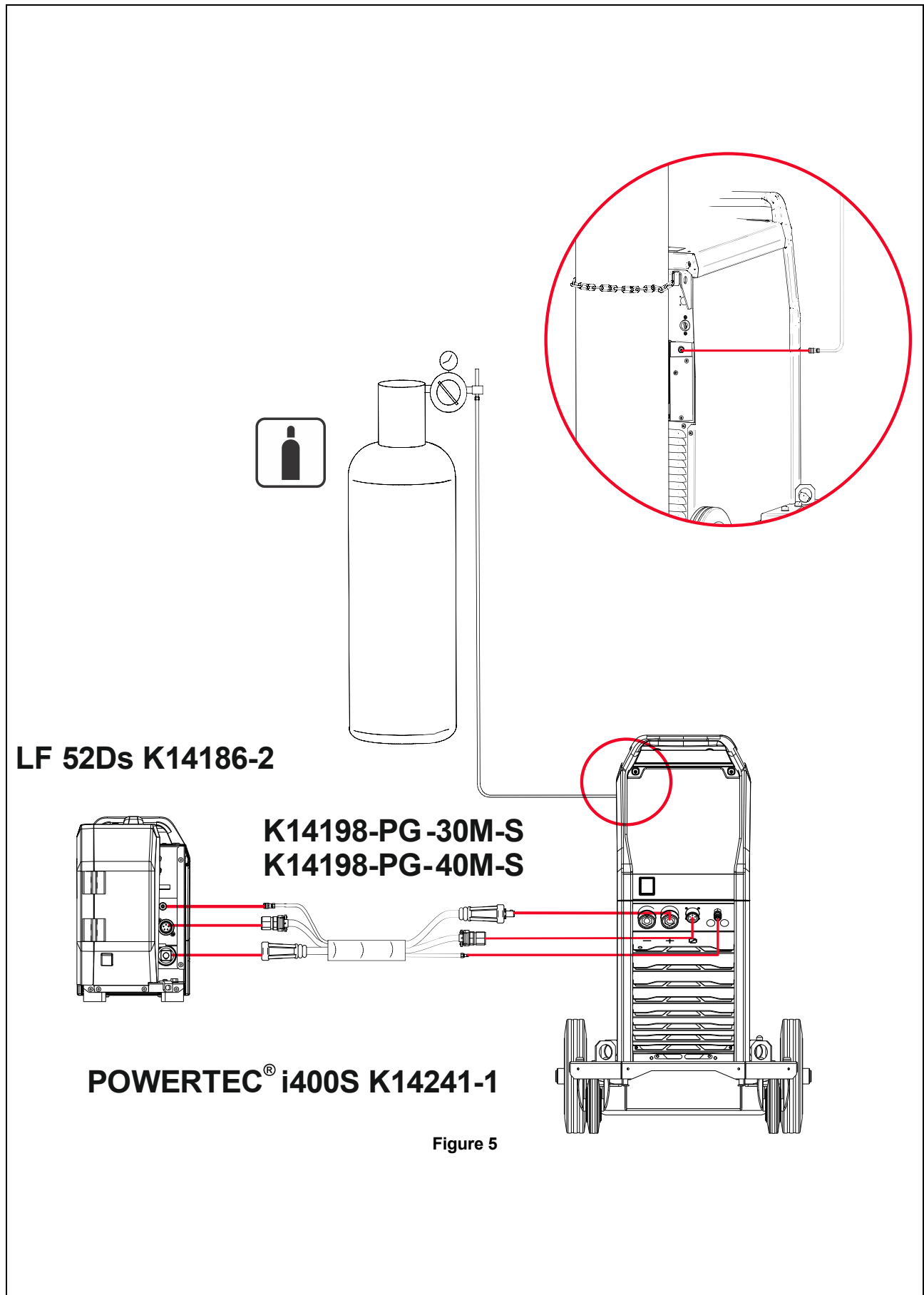

Dimension Diagram

