

INVERTEC V275-S WIRING DIAGRAM G4365-1 REV: B

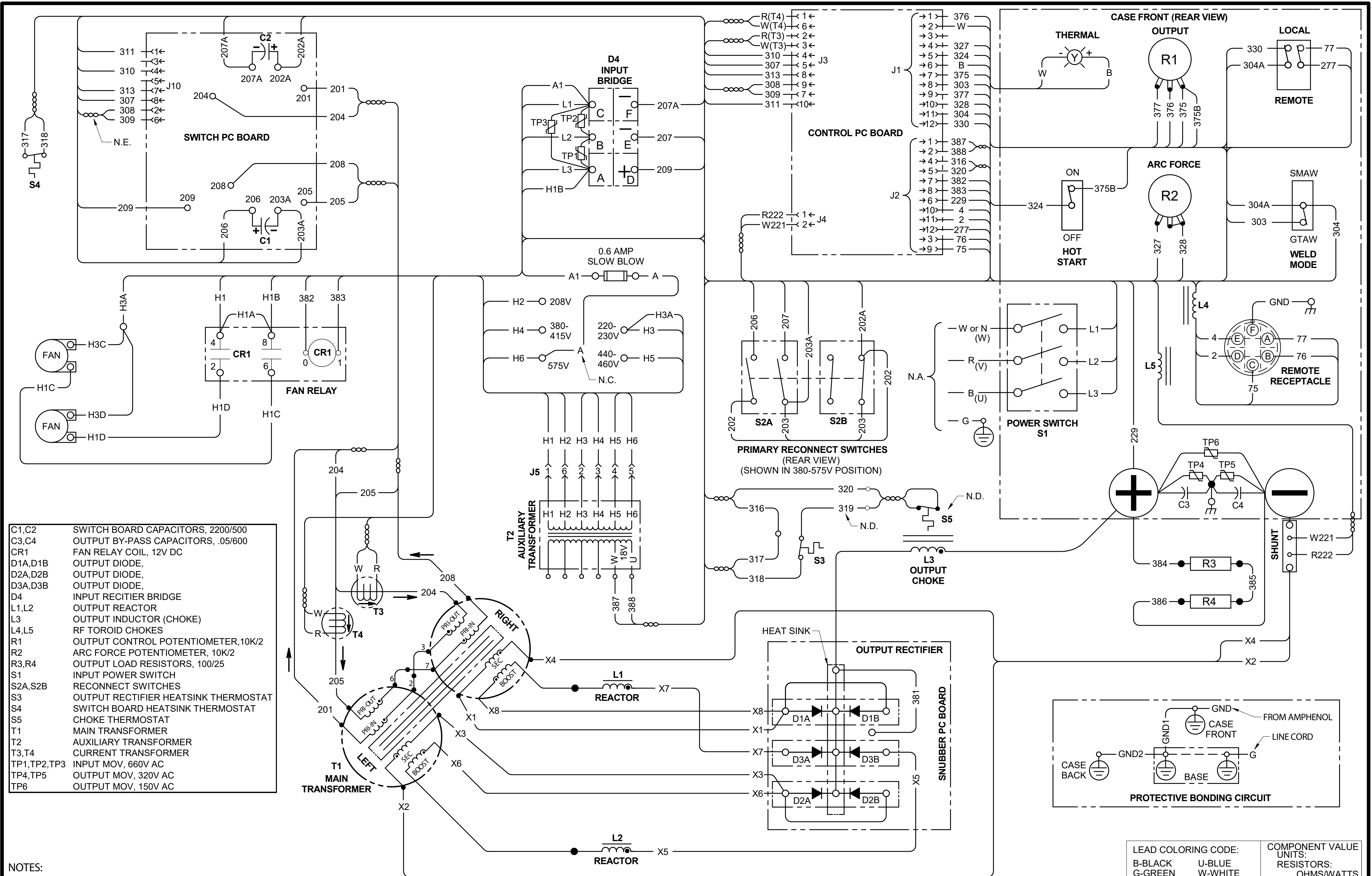

- C1,C2 SWITCH BOARD CAPACITORS, 2200/500
- C3,C4 OUTPUT BY-PASS CAPACITORS, .05/600
- CR1 FAN RELAY COIL, 12V DC
- D1A,D1B OUTPUT DIODE,
- D2A,D2B OUTPUT DIODE,
- D3A,D3B OUTPUT DIODE,
- D4 INPUT RECTIFIER BRIDGE
- L1,L2 OUTPUT REACTOR
- L3 OUTPUT INDUCTOR (CHOKE)
- L4,L5 RF TOROID CHOKES
- R1 OUTPUT CONTROL POTENTIOMETER, 10K/2
- R2 ARC FORCE POTENTIOMETER, 10K/2
- R3,R4 OUTPUT LOAD RESISTORS, 100/25
- S1 INPUT POWER SWITCH
- S2A,S2B RECONNECT SWITCHES
- S3 OUTPUT RECTIFIER HEATSINK THERMOSTAT
- S4 SWITCH BOARD HEATSINK THERMOSTAT
- S5 CHOKES THERMOSTAT
- T1 MAIN TRANSFORMER
- T2 AUXILIARY TRANSFORMER
- T3,T4 CURRENT TRANSFORMER
- TP1,TP2,TP3 INPUT MOV, 660V AC
- TP4,TP5 OUTPUT MOV, 320V AC
- TP6 OUTPUT MOV, 150V AC

NOTES:

N.A. MACHINES WITH RED, BLACK AND WHITE OR BROWN WIRE CORDS:
FOR SINGLE PHASE INPUT: CONNECT GREEN LEAD TO GROUND PER NATIONAL ELECTRICAL CODE.
 CONNECT BLACK AND WHITE OR BROWN LEADS TO SUPPLY CIRCUIT.
 WRAP RED LEAD WITH TAPE TO PROVIDE 600V. INSULATION.
FOR THREE PHASE INPUT: CONNECT GREEN LEAD TO GROUND PER NATIONAL ELECTRICAL CODE.
 CONNECT BLACK, RED & WHITE OR BROWN LEADS TO SUPPLY CIRCUIT.

N.B. SINCE COMPONENTS OR CIRCUITRY OF A PRINTED CIRCUIT BOARD MAY CHANGE WITHOUT AFFECTING THE INTERCHANGEABILITY OF A COMPLETE BOARD THIS DIAGRAM MAY NOT SHOW THE EXACT COMPONENTS OR CIRCUITRY HAVING A COMMON CDE NUMBER.

N.C. PLACE "A" LEAD ON APPROPRIATE CONNECTION FOR INPUT VOLTAGE.
 CONNECTION SHOWN IS FOR 575V OPERATION.

N.D. CHOKES THERMOSTAT AND LEAD #319 NOT PRESENT ON EARLIER MODELS.

N.E. LEADS #308 AND #309 MAY BE INTERCHANGED IN CONNECTOR PINS 2 AND 6.

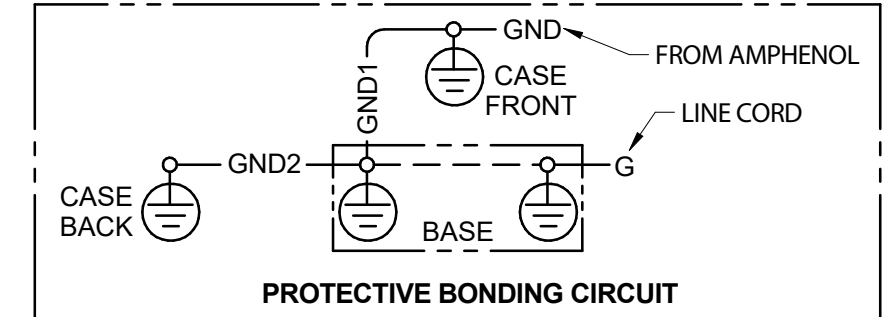

LEAD COLORING CODE:		COMPONENT VALUE UNITS:
B-BLACK	U-BLUE	RESISTORS:
G-GREEN	W-WHITE	OHMS/WATTS
O-ORANGE	Y-YELLOW	CAPACITORS:
R-RED	N-BROWN	MFD/VOLTS

