

# LF 33S

## OPERATOR'S MANUAL



ENGLISH





**THANK YOU!** For choosing the **QUALITY** of the Lincoln Electric products.

- Please check packaging and equipment for damage. Claims for material damaged in shipment must be notified immediately to the dealer.
- For ease of use, please enter your product identification data in the table below. Model Name, Code & Serial Number can be found on the machine rating plate.

Model Name:	
Code & Serial number:	
Date & Where Purchased:	

## ENGLISH INDEX

Technical Specifications .....	1
Electromagnetic Compatibility (EMC) .....	2
Safety .....	3
Installation and Operator Instructions .....	5
WEEE .....	10
Spare Parts .....	10
Authorized Service Shops Location .....	10
Electrical Schematic .....	10
Accessories .....	11
Connection configuration .....	12

# Technical Specifications

NAME		INDEX	
LF 33S		K14051-1	
INPUT VOLTAGE		WIRE FEED SPEED	
34-44 Vac		1.0-20 m/min	
RATED OUTPUT AT 40°C			
Duty Cycle 40°C (based on a 10 min. period)		Output Current	
100%		385 A	
60%		500 A	
OUTPUT RANGE			
Welding Current Range		Maximum Open Circuit Voltage	
20-500 A		113 Vdc or Vac peak	
WIRE SIZES (mm)			
Solid wires	Cored wires	Aluminium wires	
0.6 to 1.6	1.2 to 2.4	1.0 to 1.6	
PHYSICAL DIMENSIONS			
Height	Width	Length	Weight
350 mm	195 mm	530 mm	12 Kg
OTHERS			
Protection Rating		Maximum Gas Pressure	
IP23		0,5 MPa (5 bar)	
Operating Temperature		Storage Temperature	
from -10°C to +40°C		from -25°C to 55°C	

# Electromagnetic Compatibility (EMC)

01/11

This machine has been designed in accordance with all relevant directives and standards. However, it may still generate electromagnetic disturbances that can affect other systems like telecommunications (telephone, radio, and television) or other safety systems. These disturbances can cause safety problems in the affected systems. Read and understand this section to eliminate or reduce the amount of electromagnetic disturbance generated by this machine.



This machine has been designed to operate in an industrial area. To operate in a domestic area it is necessary to observe particular precautions to eliminate possible electromagnetic disturbances. The operator must install and operate this equipment as described in this manual. If any electromagnetic disturbances are detected the operator must put in place corrective actions to eliminate these disturbances, if necessary with assistance from Lincoln Electric.

Before installing the machine, the operator must check the work area for any devices that may malfunction because of electromagnetic disturbances. Consider the following.

- Input and output cables, control cables, and telephone cables that are in or adjacent to the work area and the machine.
- Radio and/or television transmitters and receivers. Computers or computer controlled equipment.
- Safety and control equipment for industrial processes. Equipment for calibration and measurement.
- Personal medical devices like pacemakers and hearing aids.
- Check the electromagnetic immunity for equipment operating in or near the work area. The operator must be sure that all equipment in the area is compatible. This may require additional protection measures.
- The dimensions of the work area to consider will depend on the construction of the area and other activities that are taking place.

Consider the following guidelines to reduce electromagnetic emissions from the machine.

- Connect the machine to the input supply according to this manual. If disturbances occur it may be necessary to take additional precautions such as filtering the input supply.
- The output cables should be as short as possible and positioned together as close as possible to each other. If possible connect the work piece to ground in order to reduce the electromagnetic emissions. The operator must check that connecting the work piece to ground does not cause problems or unsafe operating conditions for personnel and equipment.
- Shielding of cables in the work area can reduce electromagnetic emissions. This may be necessary for special applications.

## **WARNING**

EMC classification of this product is class A in accordance with electromagnetic compatibility standard EN 60974-10 which means that the product is designed to be used in an industrial environment only.









## **WARNING**





The Class A equipment is not intended for use in residential locations where the electrical power is provided by the public low-voltage supply system. There may be potential difficulties in ensuring electromagnetic compatibility in those locations, due to conducted as well as radiated disturbances.



## WARNING

This equipment have to be used by qualified personnel. Be sure that all installation, operation, maintenance and repair procedures are performed only by qualified person. Read and understand this manual before operating this equipment. Failure to follow the instructions in this manual could cause serious personal injury, loss of life, or equipment damage. Read and understand the following explanations of the warning symbols. Lincoln Electric is not responsible for damages caused by improper installation, improper care or abnormal operation.

	<p><b>WARNING:</b> This symbol indicates that instructions must be followed to avoid serious personal injury, loss of life, or equipment damage. Protect yourself and others from possible serious injury or death.</p>
	<p><b>READ AND UNDERSTAND INSTRUCTIONS:</b> Read and understand this manual before operating this equipment. Arc welding can be hazardous. Failure to follow the instructions in this manual could cause serious personal injury, loss of life, or equipment damage.</p>
	<p><b>ELECTRIC SHOCK CAN KILL:</b> Welding equipment generates high voltages. Do not touch the electrode, work clamp, or connected work pieces when this equipment is turned on. Insulate yourself from the electrode, work clamp, and connected work pieces.</p>
	<p><b>ELECTRICALLY POWERED EQUIPMENT:</b> Turn off the input power using the disconnect switch at the fuse box before working on this equipment. Ground this equipment in accordance with local electrical regulations.</p>
	<p><b>ELECTRICALLY POWERED EQUIPMENT:</b> Regularly inspect the input, electrode, and work clamp cables. If any insulation damage exists replace the cable immediately. Do not place the electrode holder directly on the welding table or any other surface in contact with the work clamp to avoid the risk of accidental arc ignition.</p>
	<p><b>ELECTROMAGNETIC FIELD MAY BE DANGEROUS:</b> Electric current flowing through any conductor creates electromagnetic field (EMF). EMF fields may interfere with some pacemakers, and welders having a pacemaker shall consult their physician before operating this equipment.</p>
	<p><b>CE COMPLIANCE:</b> This equipment complies with the European Community Directives.</p>
 <p style="font-size: small;">Optical radiation emission Category 2 (EN 12185)</p>	<p><b>ARTIFICIAL OPTICAL RADIATION:</b> According with the requirements in 2006/25/EC Directive and EN 12198 Standard, the equipment is a category 2. It makes mandatory the adoption of Personal Protective Equipment (PPE) having filter with a protection degree up to a maximum of 15, as required by EN169 Standard.</p>
	<p><b>FUMES AND GASES CAN BE DANGEROUS:</b> Welding may produce fumes and gases hazardous to health. Avoid breathing these fumes and gases. To avoid these dangers the operator must use enough ventilation or exhaust to keep fumes and gases away from the breathing zone.</p>
	<p><b>ARC RAYS CAN BURN:</b> Use a shield with the proper filter and cover plates to protect your eyes from sparks and the rays of the arc when welding or observing. To protect the skin, use suitable clothing made of durable, fireproof material. Protect other nearby personnel with suitable, non-flammable screening and warn them not to watch the arc nor expose themselves to the arc.</p>

	<p><b>WELDING SPARKS CAN CAUSE FIRE OR EXPLOSION:</b> Remove fire hazards from the welding area and have a fire extinguisher easily accessible. Welding sparks and hot materials from the welding process can easily go through small cracks and openings to adjacent areas. Do not weld on any tanks, drums, containers, or material until the proper steps have been taken to insure that no flammable or toxic vapors will be present. Never use this equipment when flammable gases, vapors or flammable liquids are present.</p>
	<p><b>WELDED MATERIALS CAN BURN:</b> Welding generates a large amount of heat. Hot surfaces and materials in work area can cause serious burns. Use gloves and pliers when touching or moving materials in the work area.</p>
	<p><b>CYLINDER MAY EXPLODE IF DAMAGED:</b> Use only certificate, compressed gas cylinders containing the correct shielding gas for the process used and properly operating regulators designed for the gas and pressure used. Always keep cylinders in an upright position securely chained to a fixed support. Do not move or transport gas cylinders with the protection cap removed. Do not allow the electrode, electrode holder, work clamp or any other electrically live part to touch a gas cylinder. Gas cylinders must be located away from areas where they may be subjected to physical damage or the welding process including sparks and heat sources.</p>
	<p><b>MOVING PARTS ARE DANGEROUS:</b> There are moving mechanical parts in this machine, which can cause serious injury. Keep your hands, body and clothing away from those parts during machine starting, operating and servicing.</p>
	<p><b>SAFETY MARK:</b> This equipment is suitable for supplying power for welding operations carried out in an environment with increased risk of electric shock.</p>

The manufacturer reserves the right to make changes and/or improvements in design without upgrade at the same time the operator's manual.

# Installation and Operator Instructions

Read this entire section before installation or operating the machine.

## Exploitation conditions

This machine can operate in harsh environments. However, it is important to use the following simple preventive measures that will ensure its long life and reliable operation:

- Do not place or operate this machine on a surface with an incline higher than 15° from horizontal.
- Do not use this machine for pipe thawing.
- This machine must be located where there is free circulation of clean air without restrictions for air movement. Do not cover the machine with paper, cloth or rags when switched on.
- Dirt and dust that can be drawn into the machine should be kept away from the item.
- This machine has a protection rating of IP23. Keep it dry when possible and do not place it on a wet ground or in puddles.
- Locate the machine away from a radio controlled machinery. Normal operation may adversely affect the operation of a nearby radio controlled machinery, which may result in injury or equipment damage. Read the section on electromagnetic compatibility in this manual.
- Do not operate in areas with an ambient temperature greater than 40°C.

## Duty cycle and Overheating

The duty cycle of a welding machine is the percentage of time in a 10 minute cycle at which the welder can operate the machine at rated welding current.

Example: 60% duty cycle:

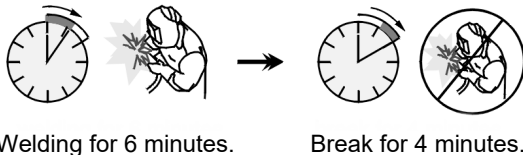

Excessive extension of the duty cycle will cause the thermal protection circuit to activate.

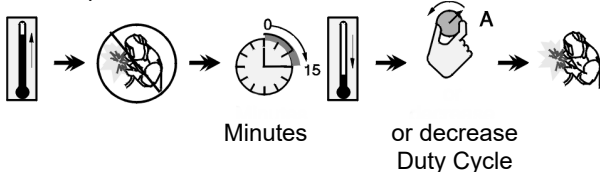

## Input Supply Connection

Check the input voltage, phase, and frequency of the power source that will be connected to this wire feeder. The allowable input voltage of the power source is indicated on the rating plate of the wire feeder. Verify the connection of grounding wires from the power source to the input source.

## Controls and Operational Features



1. EURO Socket: or connecting welding torch.
2. WFS (Wire Feed Speed) Control Knob: It enables continuous control of wire feeding speed in the range from 1.0 to 20m/min.

### ! WARNING

Before welding beginning and during Cold Inch Switch using the Pro-welding Wire Speed Control Knob [16] has also an influence on the wire feeding speed.

3. Output Voltage Control Knob: It enables continuous control of welding voltage.
4. Local/Remote Switch: It changes the control of the Output Voltage from the wire feeder Output Control [3] to Remote Control Unit and vice versa.
5. Remote Control Receptacle: If a remote control is used, it will be connected to the remote receptacle (see Accessories for ordering the desired unit).
6. Quick Connect Couplings (For water cooled model only): For connecting water cooled torches.

Warm water from torch.



Cool water to torch.



7. Digital Display A: It shows the actual welding current value (in A), and after finishing welding process, it shows the average value of the welding current.
8. Digital Display V: It shows the actual value of welding voltage (in V), and after finishing welding process, it shows the average value of welding voltage.
9. Fast-Mate Adapter: For connecting electrode touch.

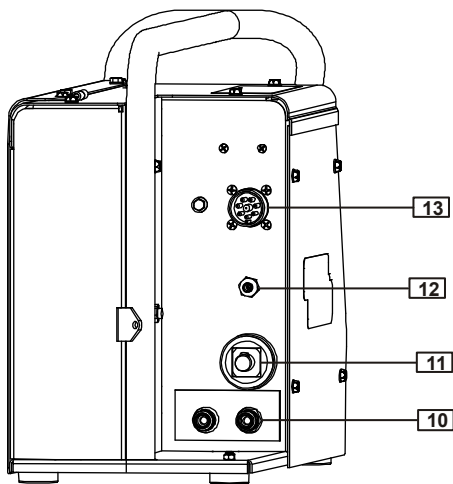

10. **Quick Connect Couplings:** If water cooled torches are used, connect water lines from water cooler here. Refer to torch and water cooler guidelines for recommended cooling liquid and flow rates.
11. **Fast-Mate Adapter:** Input power connection.
12. **Gas Connector:** Connection for gas line.
13. **Amphenol Connection:** 8-Pin connection to power source.

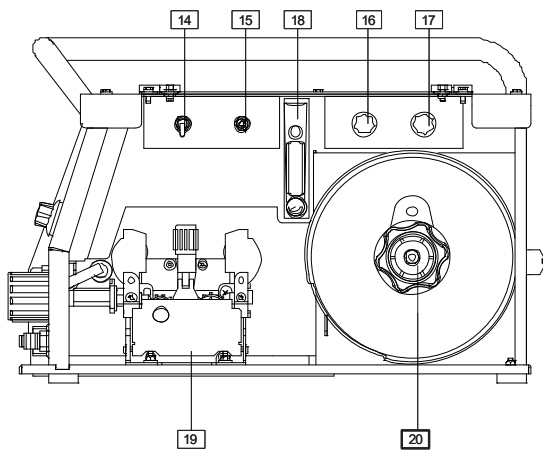

14. **Torch Mode Switch:** It enables selection of 2-step or 4-step torch mode. The functionality of 2T/4T mode is shown in the picture below:

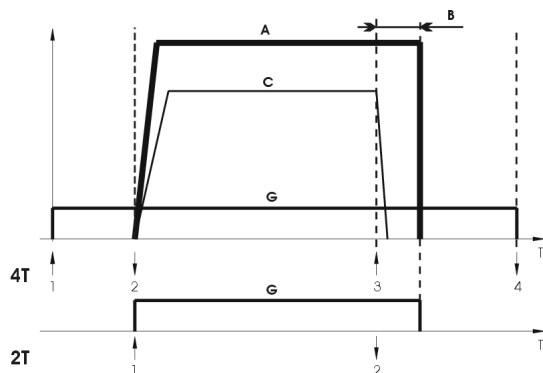

↑ Trigger pressed  
 ↓ Trigger released

- A. Welding Current.  
 B. Burnback time.  
 C. WFS.  
 G. Gas.

15. **Cold Inch / Gas Purge Switch:** This switch enables wire feeding or gas flow without turning on output voltage.
16. **Pre-welding wire speed control knob:** Enables change of the wire feed speed before starting welding process in a range from 1,0 [m/min] to the value which was set by WFS knob [2].
17. **Burnback Time Control Knob:** It enables to obtain the desired length of electrode wire, which protrudes from the tip of the torch after ending welding; adjusting range from 20 to 320ms.
18. **Gas Flow Regulator:** Regulate flow between 0-25 LPM (liter/min.).
19. **Wire Drive:** 4-Roll wire drive compatible with 37mm drive rolls.
20. **Wire Spool Support:** Maximum 5kg spools. Accepts plastic, steel and fiber spools onto 51mm spindle.

**⚠ WARNING**

The Linc Feed wire feeders must be used with the door completely closed during welding.

**Loading the Electrode Wire**

Open the side cover of the machine.

Unscrew the fastening cap of the sleeve.

Load the spool with the wire on the sleeve such that the spool turns clockwise when the wire is fed into the wire feeder.

Make sure that the spool locating pin goes into the fitting hole on the spool.

Screw in the fastening cap of the sleeve.

Put on the wire roll using the correct groove corresponding to the wire diameter.

Free the end of the wire and cut off the bent end making sure it has no burr.

**⚠ WARNING**

Sharp end of the wire can hurt.

Rotate the wire spool clockwise and thread the end of the wire into the wire feeder as far as the Euro socket.

Adjust force of pressure roll of the wire feeder properly.



## Adjustments of Brake Torque of Sleeve

To avoid spontaneous unrolling of the welding wire the sleeve is fitted with a brake.

Adjustment is carried by rotation of its screw M8, which is placed inside of the sleeve frame after unscrewing the fastening cap of the sleeve.

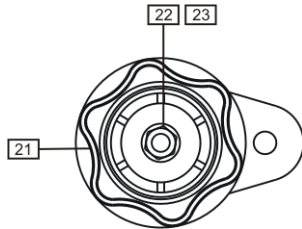

- 21. Fastening cap.
- 22. Adjusting screw M8.
- 23. Pressing spring.

Turning the screw M8 clockwise increases the spring tension and you can increase the brake torque.

Turning the screw M8 counterclockwise decreases the spring tension and you can decrease the brake torque.

## Adjusting of Force of Pressure Roll Force

Pressure force is adjusted by turning the adjustment nut clockwise to increase force, counterclockwise to decrease force.

### WARNING

If the roll pressure is too low the roll will slide on the wire. If the roll pressure is set too high the wire may be deformed, which will cause feeding problems in the welding gun. The pressure force should be set properly. Decrease the pressure force slowly until the wire just begins to slide on the drive roll and then increase the force slightly by turning of the adjustment nut by one turn.

## Inserting Electrode Wire into Welding Torch

Connect the proper welding torch to the Euro socket, the rated parameters of the torch and of the welding source shall match.

Remove the gas diffuser and contact tip from the welding torch.

Set the wire feeding speed in the position of about 10m/min by the WFS knob [2].

Switch the Cold Inch / Gas Purge switch [15] in the position "Cold Inch" and keep in this position until the electrode wire leaves the contact tip of the welding torch.

### WARNING

Take precaution to keep eyes and hands away from the end of the torch while feeding wire.

### WARNING

Once the wire has finished feeding through the welding gun turn the wire supply off before replacing to contact tip and gas diffuser.

## Welding methods

### Welding with MIG / MAG method

To begin welding process with MIG/MAG method in manual mode you should:

- Switch ON the machine which supplies the wire feeder.
- Insert the electrode wire into the torch using "Cold Inch" switch [15].
- Check gas flow with "Gas Purge" switch [15].
- According to selected welding mode and material thickness set the proper welding voltage with knob [3] and the wire feeding speed with WFS knob [2].
- Obeying the appropriate rules, you can begin to weld.

### Welding with MMA (SMAW) method

The LF33S wire feeder enable Manual Metal Arc welding process that uses a consumable electrode coated in flux by cooperating with CC (constant current) power sources like DC 400, DC 655 or V350 PRO.

In order to start welding process with MMA method you should:

- Connect the wire feeder to over mentioned CC power source by the combined cable.
- Connect welding torch into output socket [9].
- Switch the power source in CC mode.
- Set required welding current by adjusting knob [3].
- Obeying appropriate rules you can begin to weld.

### LF33S compatibility functions with source

		LF33S + CC/CV source					
		DC 400		DC 655		V 350 PRO	
		LF 33S Knob [3] Settings before welding					
		CC	CV	CC	CV	CC	CV
V	No	√	No	√	No	√	
A	√	No	√	No	On source	No	
		LF 33S Display during and after welding					
		CC	CV	CC	CV	CC	CV
V	√	√	√	√	√	√	
A	√	√	√	√	√	√	

## Changing Driving Rolls

The wire feeder is equipped with drive rolls for the wire of 1.0 and 1.2mm. For others wire sizes, is available the proper drive rolls kit (see chapter Accessories for ordering the desired kit). Below the drive rolls replacement procedure:

- Switch off the machine which supplies the wire feeder.
- Release the pressure roll lever [24].
- Unscrew the fastening cap [25].
- Open the protection cover [27].
- Change the drive rolls [26] with the compatible ones corresponding to the used wire.

### **WARNING**

For wires with the diameter greater than 1.6mm, the following parts are to be changed:

- The guide tube of the feeding console [28].
  - The guide tube of the Euro socket [29].
- Replace and tighten the protection cover [27] to the drive rolls.
  - Screw the protection cover by fastening screws [25].

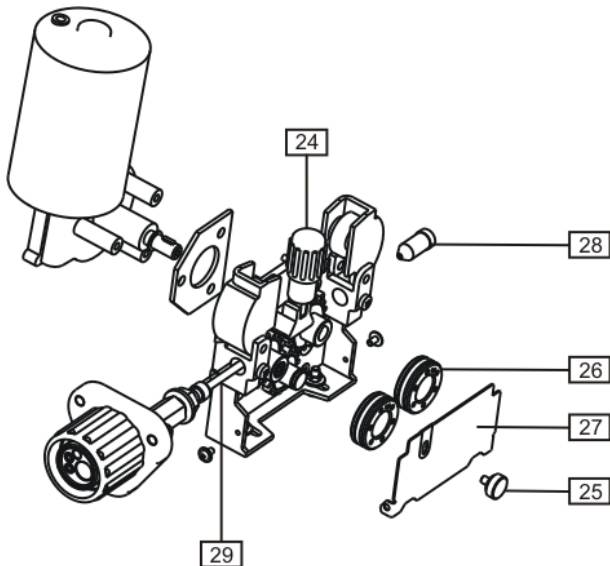

## Gas Connection

### **WARNING**



- CYLINDER may explode if damaged.
- Always fix the gas cylinder securely in an upright position, against a cylinder wall rack or purpose-made cylinder cart.
- Keep cylinder away from areas where it may be damaged, heated or electrical circuits to prevent possible explosion or fire.
- Keep cylinder away from welding or other live electrical circuits.
- Never lift welder with cylinder attached.
- Never allow welding electrode to touch cylinder.
- Build up of shielding gas may harm health or kill. Use in a well-ventilated area to avoid gas accumulation.
- Close the gas cylinder valves thoroughly when not in use to avoid leaks.

### **WARNING**

Welding machine supports all suitable shielding gases at a maximum pressure of 5,0 bar.

### **WARNING**

Before use, make sure that the gas cylinder contains gas suitable for the intended purpose.

- Turn off input power at the welding power source.
- Install a proper gas flow regulator to the gas cylinder.
- Connect the gas hose to the regulator using the hose clamp.
- The other end of the gas hose connect to the gas connector on the power source rear panel or directly to the quick connector located on the rear panel of the wire feeder [12]. More details you will find in power source instruction manual.
- Connect by dedicated interconnection cable (see „Accessories“ chapter) wire feeder and power source.
- Turn on input power at the welding power source.
- Open the gas cylinder valve.
- Adjust the shielding gas flow of the gas regulator.
- Check gas flow with Gas Purge Switch [15].

### **WARNING**

To weld GMAW process with CO<sub>2</sub> shielding gas, CO<sub>2</sub> gas heater should be used.

## Maintenance

### **WARNING**

For any repair operations, modifications or maintenances, it is recommended to contact the nearest Technical Service Center or Lincoln Electric. Repairs and modifications performed by unauthorized service or personnel will cause the loss of the manufacturer's warranty

Any noticeable damage should be reported immediately and repaired.

#### **Routine maintenance (everyday)**

- Check condition of insulation and connections of the work leads and insulation of power lead. If any insulation damage exists replace the lead immediately.
- Remove the spatters from the welding gun nozzle. Spatters could interfere with the shielding gas flow to the arc.
- Check the welding gun condition: replace it, if necessary.
- Check condition and operation of the cooling fan. Keep clean its airflow slots.

#### **Periodic maintenance (every 200 working hours but at least once a year)**

Perform the routine maintenance and, in addition:

- Keep the machine clean. Using a dry (and low pressure) airflow, remove the dust from the external case and from the cabinet inside.
- If it is required, clean and tighten all weld terminals.

The frequency of the maintenance operations may vary in accordance with the working environment where the machine is placed.

### **WARNING**

Do not touch electrically live parts.

### **WARNING**

Before removed case, machine has to be turned off and the power lead has to be disconnected from mains socket.

### **WARNING**

Mains supply network must be disconnected from the machine before each maintenance and service. After each repair, perform proper tests to ensure safety.

## Customer Assistance Policy

The business of The Lincoln Electric Company is manufacturing and selling high quality welding equipment, consumables, and cutting equipment. Our challenge is to meet the needs of our customers and to exceed their expectations. On occasion, purchasers may ask Lincoln Electric for advice or information about their use of our products. We respond to our customers based on the best information in our possession at that time. Lincoln Electric is not in a position to warrant or guarantee such advice, and assumes no liability, with respect to such information or advice. We expressly disclaim any warranty of any kind, including any warranty of fitness for any customer's particular purpose, with respect to such information or advice. As a matter of practical consideration, we also cannot assume any responsibility for updating or correcting any such information or advice once it has been given, nor does the provision of information or advice create, expand or alter any warranty with respect to the sale of our products

Lincoln Electric is a responsive manufacturer, but the selection and use of specific products sold by Lincoln Electric is solely within the control of, and remains the sole responsibility of the customer. Many variables beyond the control of Lincoln Electric affect the results obtained in applying these types of fabrication methods and service requirements.

Subject to Change – This information is accurate to the best of our knowledge at the time of printing. Please refer to [www.lincolnelectric.com](http://www.lincolnelectric.com) for any updated information.

# WEEE

07/06



Do not dispose of electrical equipment together with normal waste!  
In observance of European Directive 2012/19/EC on Waste Electrical and Electronic Equipment (WEEE) and its implementation in accordance with national law, electrical equipment that has reached the end of its life must be collected separately and returned to an environmentally compatible recycling facility. As the owner of the equipment, you should get information on approved collection systems from our local representative.  
By applying this European Directive you will protect the environment and human health!

# Spare Parts

12/05

## Part List reading instructions

- Do not use this part list for a machine if its code number is not listed. Contact the Lincoln Electric Service Department for any code number not listed.
- Use the illustration of assembly page and the table below to determine where the part is located for your particular code machine.
- Use only the parts marked "X" in the column under the heading number called for in the assembly page (# indicate a change in this printing).

First, read the Part List reading instructions above, then refer to the "Spare Part" manual supplied with the machine that contains a picture-descriptive part number cross-reference.

# Authorized Service Shops Location

09/16

- The purchaser must contact a Lincoln Authorized Service Facility (LASF) about any defect claimed under Lincoln's warranty period.
- Contact your local Lincoln Sales Representative for assistance in locating a LASF or go to [www.lincolnelectric.com/en-gb/Support/Locator](http://www.lincolnelectric.com/en-gb/Support/Locator).

# Electrical Schematic

Refer to the "Spare Part" manual supplied with the machine.

## Accessories

<b>OPTIONS &amp; ACCESSORIES</b>	
K10347-PG-xxM	Source/wire feeder cable (gas). Available in 5, 10 or 15m.
K10347-PGW-xxM	Source/wire feeder cable (gas and water). Available in 5, 10 or 15m.
K14070-1	Hand Amptrol (welding voltage & wire feeder speed WFS).
K-14068-1	Skid to LF33S.
K-14069-1	Limit Switch.
<b>ROLL KIT FOR SOLID WIRES</b>	
KP10344-0.8	0,6-0,8mm
KP10344-1.0	0,8-1,0mm
KP10344-1.2	1,0-1,2mm
KP10344-1.6	1,2-1,6mm
<b>ROLL KIT FOR CORED WIRES</b>	
KP10344-1.6C	1.0-1.6mm
KP10344-2.4C	1.6-2.4mm
<b>ROLL KIT FOR ALUMINIUM WIRES</b>	
KP10344-1.2A	1,0-1,2mm
KP10344-1.6A	1,2-1,6mm

# Connection configuration

