

# CLASSIC 300 MP MACHINE SCHEMATIC L17022 REV: B

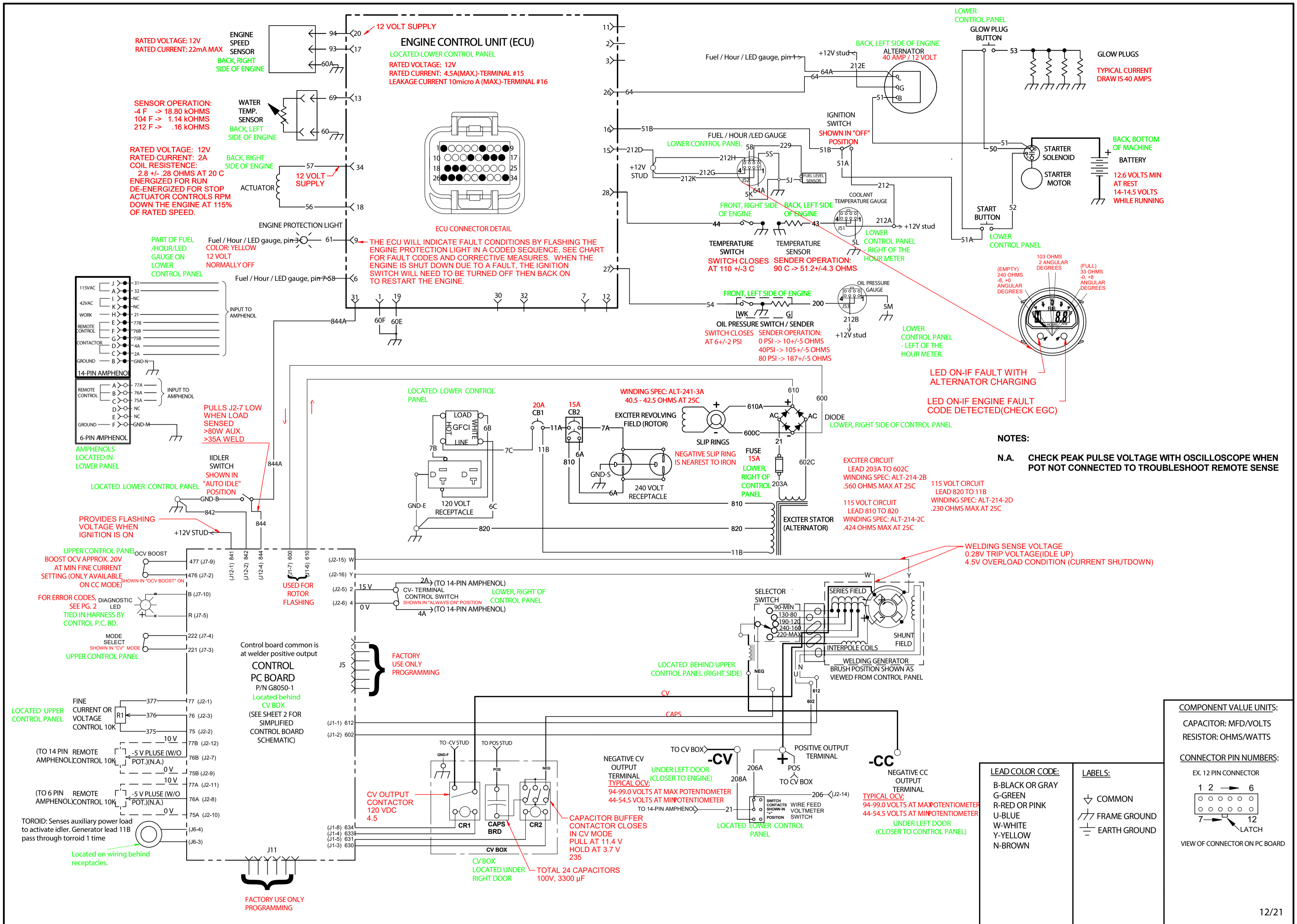

*Diagnostic LED Flash Codes		
Long Flash	Short Flash	Description
2	1	Field coil shorted- fault can only be reset by re-starting welder
2	3	Welder output short circuit or overload, fault resets by re-starting welder
3	2	Negative armature in cvmode code
3	3	VArm>90V in cvmode code after CR2enable
4	2	Control board 18V Supply is under 16.2V
4	1	Control board 36V Supply is under 29.2V
5	1	Control board serial communication error
4	3	Control board 15V supply under code

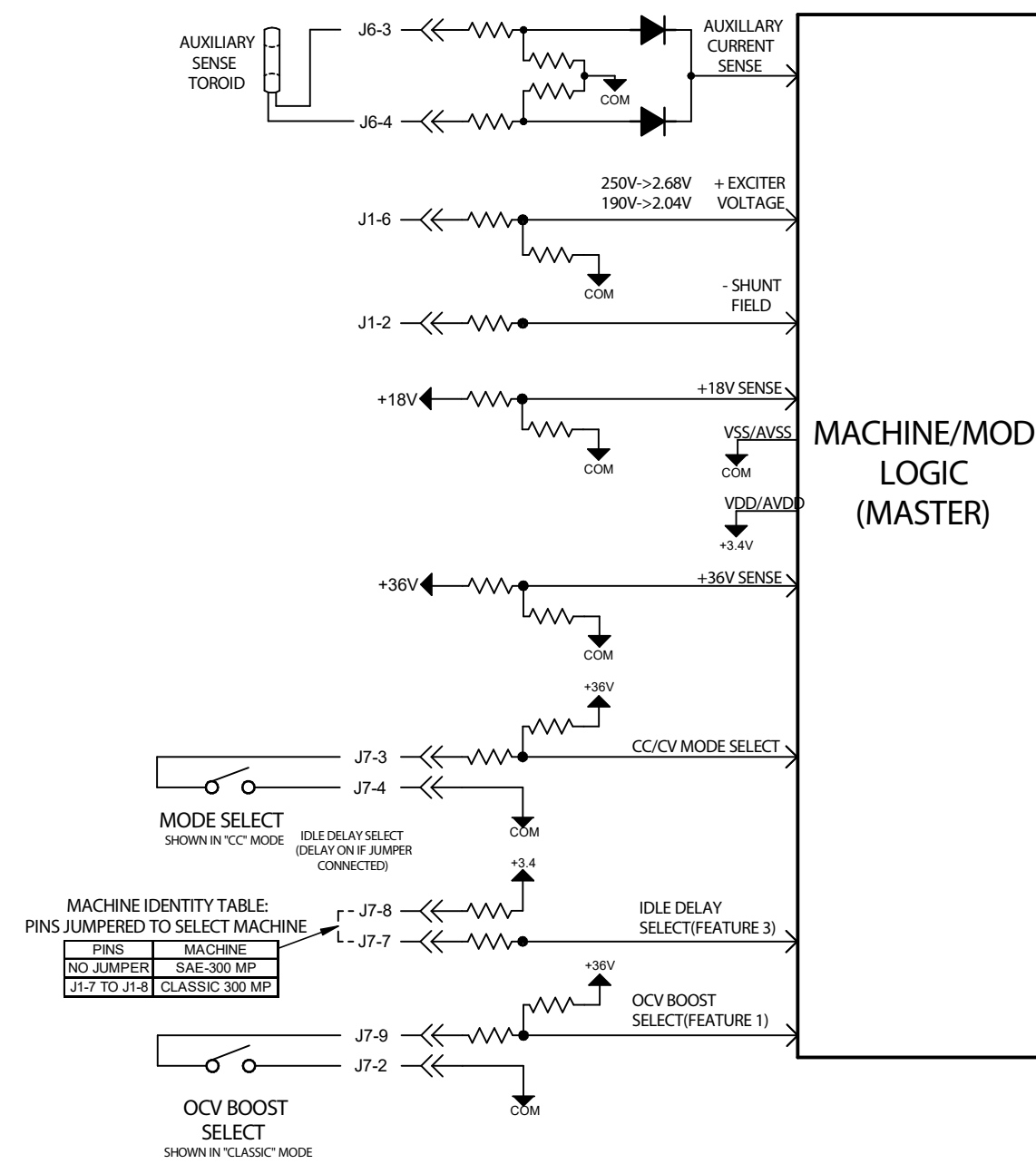

### CONNECTORS

- J1 FIELD, EXCITER, CR1, CR2
- J2 WELD CIRCUIT
- J6 TOROID
- J7 MACH. SELECT, OCV MODE, DIAG. LED
- J12 FLASHING, IDLER

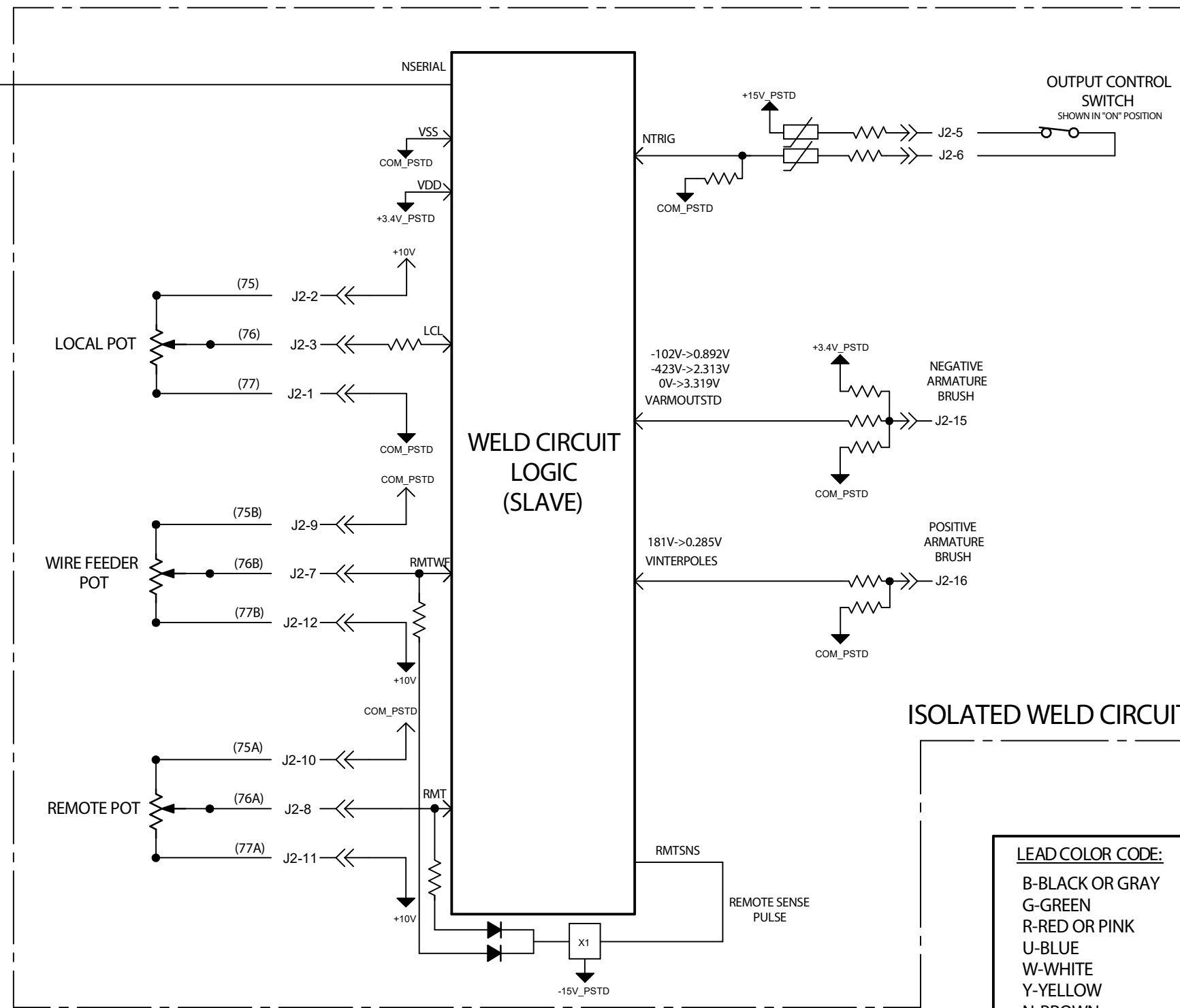
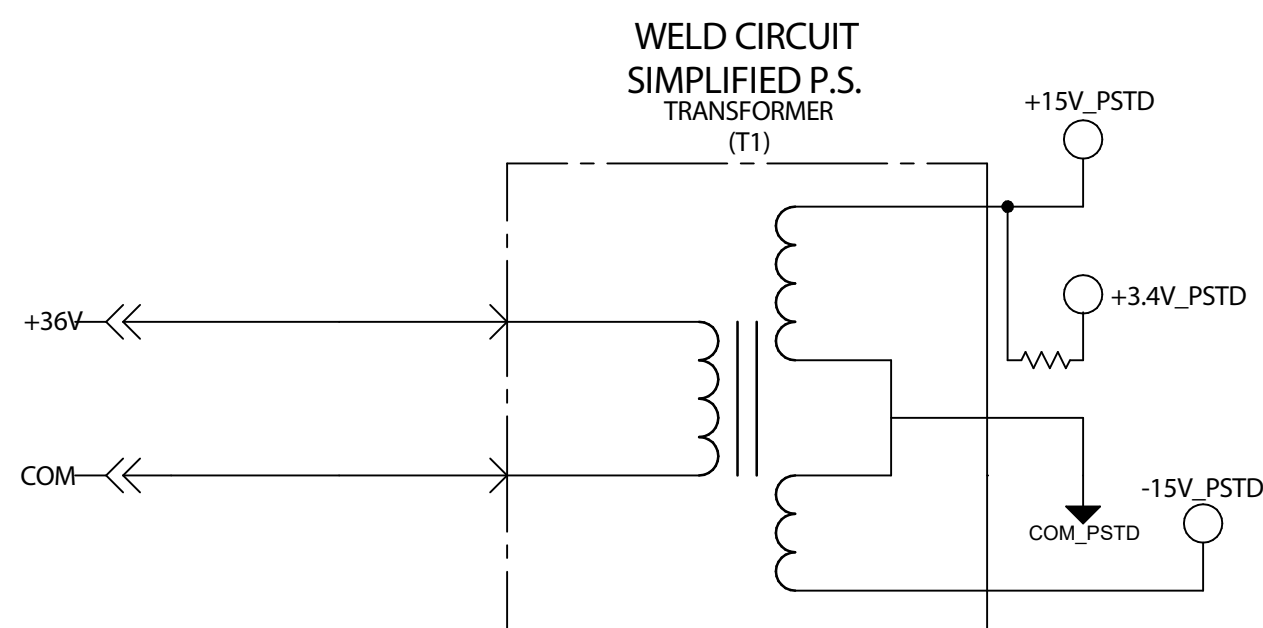

**LEAD COLOR CODE:**  
 B-BLACK OR GRAY  
 G-GREEN  
 R-RED OR PINK  
 U-BLUE  
 W-WHITE  
 Y-YELLOW  
 N-BROWN

**LABELS:**  
 COMMON  
 FRAME GROUND  
 EARTH GROUND

**COMPONENT VALUE UNITS:**  
 CAPACITOR: MFD/VOLTS  
 RESISTOR: OHMS/WATTS

**CONNECTOR PIN NUMBERS:**  
 EX. 12 PIN CONNECTOR

VIEW OF CONNECTOR ON PC BOARD