

Operator's Manual

ACTIV8X[®] PIPE[™]

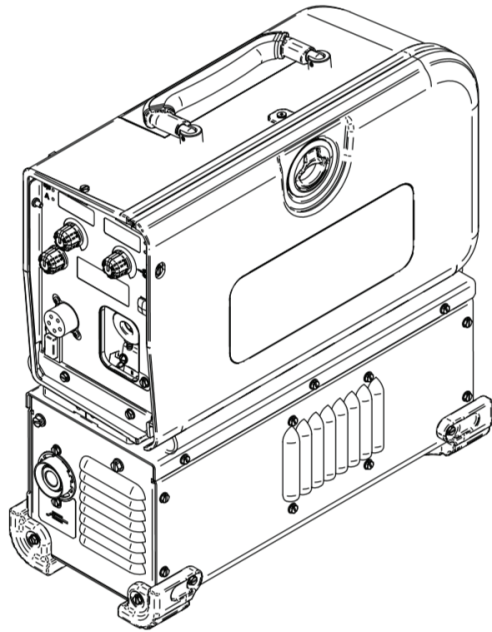

For use with machines having Code Numbers:

Activ8X Pipe: 13020

Activ8X Pipe CE: 13205



Register your machine:

www.lincolnelectric.com/register

Authorized Service and Distributor Locator:

www.lincolnelectric.com/locator

Save for future reference

Date Purchased

Code: (ex: 10859)

Serial: (ex: U1060512345)

THANK YOU FOR SELECTING A QUALITY PRODUCT BY LINCOLN ELECTRIC.

PLEASE EXAMINE CARTON AND EQUIPMENT FOR DAMAGE IMMEDIATELY

When this equipment is shipped, title passes to the purchaser upon receipt by the carrier. Consequently, claims for material damaged in shipment must be made by the purchaser against the transportation company at the time the shipment is received.

SAFETY DEPENDS ON YOU

Lincoln arc welding and cutting equipment is designed and built with safety in mind. However, your overall safety can be increased by proper installation ... and thoughtful operation on your part. **DO NOT INSTALL, OPERATE OR REPAIR THIS EQUIPMENT WITHOUT READING THIS MANUAL AND THE SAFETY PRECAUTIONS CONTAINED THROUGHOUT.** And, most importantly, think before you act and be careful.

WARNING

This statement appears where the information must be followed exactly to avoid serious personal injury or loss of life.

CAUTION

This statement appears where the information must be followed to avoid minor personal injury or damage to this equipment.



KEEP YOUR HEAD OUT OF THE FUMES.

DON'T get too close to the arc. Use corrective lenses if necessary to stay a reasonable distance away from the arc.

READ and obey the Safety Data Sheet (SDS) and the warning label that appears on all containers of welding materials.

USE ENOUGH VENTILATION or exhaust at the arc, or both, to keep the fumes and gases from your breathing zone and the general area.

IN A LARGE ROOM OR OUTDOORS, natural ventilation may be adequate if you keep your head out of the fumes (See below).

USE NATURAL DRAFTS or fans to keep the fumes away from your face.

If you develop unusual symptoms, see your supervisor. Perhaps the welding atmosphere and ventilation system should be checked.

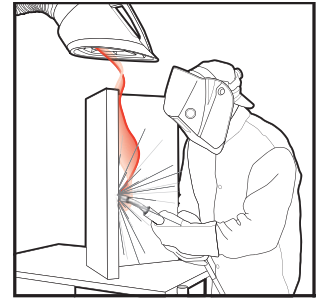

WEAR CORRECT EYE, EAR & BODY PROTECTION

PROTECT your eyes and face with welding helmet properly fitted and with proper grade of filter plate (See ANSI Z49.1).

PROTECT your body from welding spatter and arc flash with protective clothing including woolen clothing, flame-proof apron and gloves, leather leggings, and high boots.

PROTECT others from splatter, flash, and glare with protective screens or barriers.

IN SOME AREAS, protection from noise may be appropriate.

BE SURE protective equipment is in good condition.

Also, wear safety glasses in work area **AT ALL TIMES.**



SPECIAL SITUATIONS

DO NOT WELD OR CUT containers or materials which previously had been in contact with hazardous substances unless they are properly cleaned. This is extremely dangerous.

DO NOT WELD OR CUT painted or plated parts unless special precautions with ventilation have been taken. They can release highly toxic fumes or gases.

Additional precautionary measures

PROTECT compressed gas cylinders from excessive heat, mechanical shocks, and arcs; fasten cylinders so they cannot fall.

BE SURE cylinders are never grounded or part of an electrical circuit.

REMOVE all potential fire hazards from welding area.

ALWAYS HAVE FIRE FIGHTING EQUIPMENT READY FOR IMMEDIATE USE AND KNOW HOW TO USE IT.



SECTION A: WARNINGS



CALIFORNIA PROPOSITION 65 WARNINGS



WARNING: Breathing diesel engine exhaust exposes you to chemicals known to the State of California to cause cancer and birth defects, or other reproductive harm.

- Always start and operate the engine in a well-ventilated area.
- If in an exposed area, vent the exhaust to the outside.
- Do not modify or tamper with the exhaust system.
- Do not idle the engine except as necessary.

For more information go to www.P65warnings.ca.gov/diesel

WARNING: This product, when used for welding or cutting, produces fumes or gases which contain chemicals known to the State of California to cause birth defects and, in some cases, cancer. (California Health & Safety Code § 25249.5 *et seq.*)



WARNING: Cancer and Reproductive Harm
www.P65warnings.ca.gov

ARC WELDING CAN BE HAZARDOUS. PROTECT YOURSELF AND OTHERS FROM POSSIBLE SERIOUS INJURY OR DEATH. KEEP CHILDREN AWAY. PACEMAKER WEARERS SHOULD CONSULT WITH THEIR DOCTOR BEFORE OPERATING.

Read and understand the following safety highlights. For additional safety information, it is strongly recommended that you purchase a copy of "Safety in Welding & Cutting - ANSI Standard Z49.1" from the American Welding Society, P.O. Box 351040, Miami, Florida 33135 or CSA Standard W117.2. A Free copy of "Arc Welding Safety" booklet E205 is available from the Lincoln Electric Company, 22801 St. Clair Avenue, Cleveland, Ohio 44117-1199.

BE SURE THAT ALL INSTALLATION, OPERATION, MAINTENANCE AND REPAIR PROCEDURES ARE PERFORMED ONLY BY QUALIFIED INDIVIDUALS.



FOR ENGINE POWERED EQUIPMENT.

- Turn the engine off before troubleshooting and maintenance work unless the maintenance work requires it to be running.
- Operate engines in open, well-ventilated areas or vent the engine exhaust fumes outdoors.
- Do not add the fuel near an open flame welding arc or when the engine is running. Stop the engine and allow it to cool before refueling to prevent spilled fuel from vaporizing on contact



with hot engine parts and igniting. Do not spill fuel when filling tank. If fuel is spilled, wipe it up and do not start engine until fumes have been eliminated.

- Keep all equipment safety guards, covers and devices in position and in good repair. Keep hands, hair, clothing and tools away from V-belts, gears, fans and all other moving parts when starting, operating or repairing equipment.
- In some cases it may be necessary to remove safety guards to perform required maintenance. Remove guards only when necessary and replace them when the maintenance requiring their removal is complete. Always use the greatest care when working near moving parts.
- Do not put your hands near the engine fan. Do not attempt to override the governor or idler by pushing on the throttle control rods while the engine is running.
- To prevent accidentally starting gasoline engines while turning the engine or welding generator during maintenance work, disconnect the spark plug wires, distributor cap or magneto wire as appropriate.
- To avoid scalding, do not remove the radiator pressure cap when the engine is hot.
- Using a generator indoors CAN KILL YOU IN MINUTES.
- Generator exhaust contains carbon monoxide. This is a poison you cannot see or smell.
- NEVER use inside a home or garage, EVEN IF doors and windows are open.
- Only use OUTSIDE and far away from windows, doors and vents.
- Avoid other generator hazards. READ MANUAL BEFORE USE.



ELECTRIC AND MAGNETIC FIELDS MAY BE DANGEROUS



- Electric current flowing through any conductor causes localized Electric and Magnetic Fields (EMF). Welding current creates EMF fields around welding cables and welding machines
- EMF fields may interfere with some pacemakers, and welders having a pacemaker should consult their physician before welding.
- Exposure to EMF fields in welding may have other health effects which are now not known.
- All welders should use the following procedures in order to minimize exposure to EMF fields from the welding circuit:
 - Route the electrode and work cables together - Secure them with tape when possible.
 - Never coil the electrode lead around your body.
 - Do not place your body between the electrode and work cables. If the electrode cable is on your right side, the work cable should also be on your right side.
 - Connect the work cable to the workpiece as close as possible to the area being welded.
 - Do not work next to welding power source.



ELECTRIC SHOCK CAN KILL.



- 3.a. The electrode and work (or ground) circuits are electrically “hot” when the welder is on. Do not touch these “hot” parts with your bare skin or wet clothing. Wear dry, hole-free gloves to insulate hands.
- 3.b. Insulate yourself from work and ground using dry insulation. Make certain the insulation is large enough to cover your full area of physical contact with work and ground.

In addition to the normal safety precautions, if welding must be performed under electrically hazardous conditions (in damp locations or while wearing wet clothing; on metal structures such as floors, gratings or scaffolds; when in cramped positions such as sitting, kneeling or lying, if there is a high risk of unavoidable or accidental contact with the workpiece or ground) use the following equipment:

- Semiautomatic DC Constant Voltage (Wire) Welder.
 - DC Manual (Stick) Welder.
 - AC Welder with Reduced Voltage Control.
- 3.c. In semiautomatic or automatic wire welding, the electrode, electrode reel, welding head, nozzle or semiautomatic welding gun are also electrically “hot”.
 - 3.d. Always be sure the work cable makes a good electrical connection with the metal being welded. The connection should be as close as possible to the area being welded.
 - 3.e. Ground the work or metal to be welded to a good electrical (earth) ground.
 - 3.f. Maintain the electrode holder, work clamp, welding cable and welding machine in good, safe operating condition. Replace damaged insulation.
 - 3.g. Never dip the electrode in water for cooling.
 - 3.h. Never simultaneously touch electrically “hot” parts of electrode holders connected to two welders because voltage between the two can be the total of the open circuit voltage of both welders.
 - 3.i. When working above floor level, use a safety belt to protect yourself from a fall should you get a shock.
 - 3.j. Also see Items 6.c. and 8.



ARC RAYS CAN BURN.



- 4.a. Use a shield with the proper filter and cover plates to protect your eyes from sparks and the rays of the arc when welding or observing open arc welding. Headshield and filter lens should conform to ANSI Z87.1 standards.
- 4.b. Use suitable clothing made from durable flame-resistant material to protect your skin and that of your helpers from the arc rays.
- 4.c. Protect other nearby personnel with suitable, non-flammable screening and/or warn them not to watch the arc nor expose themselves to the arc rays or to hot spatter or metal.



FUMES AND GASES CAN BE DANGEROUS.



- 5.a. Welding may produce fumes and gases hazardous to health. Avoid breathing these fumes and gases. When welding, keep your head out of the fume. Use enough ventilation and/or exhaust at the arc to keep fumes and gases away from the breathing zone. **When welding hardfacing (see instructions on container or SDS) or on lead or cadmium plated steel and other metals or coatings which produce highly toxic fumes, keep exposure as low as possible and within applicable OSHA PEL and ACGIH TLV limits using local exhaust or mechanical ventilation unless exposure assessments indicate otherwise. In confined spaces or in some circumstances, outdoors, a respirator may also be required. Additional precautions are also required when welding on galvanized steel.**
- 5.b. The operation of welding fume control equipment is affected by various factors including proper use and positioning of the equipment, maintenance of the equipment and the specific welding procedure and application involved. Worker exposure level should be checked upon installation and periodically thereafter to be certain it is within applicable OSHA PEL and ACGIH TLV limits.
- 5.c. Do not weld in locations near chlorinated hydrocarbon vapors coming from degreasing, cleaning or spraying operations. The heat and rays of the arc can react with solvent vapors to form phosgene, a highly toxic gas, and other irritating products.
- 5.d. Shielding gases used for arc welding can displace air and cause injury or death. Always use enough ventilation, especially in confined areas, to insure breathing air is safe.
- 5.e. Read and understand the manufacturer’s instructions for this equipment and the consumables to be used, including the Safety Data Sheet (SDS) and follow your employer’s safety practices. SDS forms are available from your welding distributor or from the manufacturer.
- 5.f. Also see item 1.b.



WELDING AND CUTTING SPARKS CAN CAUSE FIRE OR EXPLOSION.

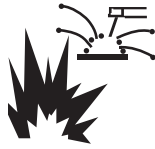

- 6.a. Remove fire hazards from the welding area. If this is not possible, cover them to prevent the welding sparks from starting a fire. Remember that welding sparks and hot materials from welding can easily go through small cracks and openings to adjacent areas. Avoid welding near hydraulic lines. Have a fire extinguisher readily available.
- 6.b. Where compressed gases are to be used at the job site, special precautions should be used to prevent hazardous situations. Refer to "Safety in Welding and Cutting" (ANSI Standard Z49.1) and the operating information for the equipment being used.
- 6.c. When not welding, make certain no part of the electrode circuit is touching the work or ground. Accidental contact can cause overheating and create a fire hazard.
- 6.d. Do not heat, cut or weld tanks, drums or containers until the proper steps have been taken to insure that such procedures will not cause flammable or toxic vapors from substances inside. They can cause an explosion even though they have been "cleaned". For information, purchase "Recommended Safe Practices for the Preparation for Welding and Cutting of Containers and Piping That Have Held Hazardous Substances", AWS F4.1 from the American Welding Society (see address above).
- 6.e. Vent hollow castings or containers before heating, cutting or welding. They may explode.
- 6.f. Sparks and spatter are thrown from the welding arc. Wear oil free protective garments such as leather gloves, heavy shirt, cuffless trousers, high shoes and a cap over your hair. Wear ear plugs when welding out of position or in confined places. Always wear safety glasses with side shields when in a welding area.
- 6.g. Connect the work cable to the work as close to the welding area as practical. Work cables connected to the building framework or other locations away from the welding area increase the possibility of the welding current passing through lifting chains, crane cables or other alternate circuits. This can create fire hazards or overheat lifting chains or cables until they fail.
- 6.h. Also see item 1.c.
- 6.i. Read and follow NFPA 51B "Standard for Fire Prevention During Welding, Cutting and Other Hot Work", available from NFPA, 1 Batterymarch Park, PO box 9101, Quincy, MA 022690-9101.
- 6.j. Do not use a welding power source for pipe thawing.



CYLINDER MAY EXPLODE IF DAMAGED.



- 7.a. Use only compressed gas cylinders containing the correct shielding gas for the process used and properly operating regulators designed for the gas and pressure used. All hoses, fittings, etc. should be suitable for the application and maintained in good condition.
- 7.b. Always keep cylinders in an upright position securely chained to an undercarriage or fixed support.
- 7.c. Cylinders should be located:
 - Away from areas where they may be struck or subjected to physical damage.
 - A safe distance from arc welding or cutting operations and any other source of heat, sparks, or flame.
- 7.d. Never allow the electrode, electrode holder or any other electrically "hot" parts to touch a cylinder.
- 7.e. Keep your head and face away from the cylinder valve outlet when opening the cylinder valve.
- 7.f. Valve protection caps should always be in place and hand tight except when the cylinder is in use or connected for use.
- 7.g. Read and follow the instructions on compressed gas cylinders, associated equipment, and CGA publication P-1, "Precautions for Safe Handling of Compressed Gases in Cylinders," available from the Compressed Gas Association, 14501 George Carter Way Chantilly, VA 20151.



FOR ELECTRICALLY POWERED EQUIPMENT.



- 8.a. Turn off input power using the disconnect switch at the fuse box before working on the equipment.
- 8.b. Install equipment in accordance with the U.S. National Electrical Code, all local codes and the manufacturer's recommendations.
- 8.c. Ground the equipment in accordance with the U.S. National Electrical Code and the manufacturer's recommendations.

Refer to
<http://www.lincolnelectric.com/safety>
for additional safety information.

GENERAL DESCRIPTION	3
RECOMMENDED PROCESSES	3
PROCESS LIMITATIONS.....	3
EQUIPMENT LIMITATIONS	3
RECOMMENDED POWER SOURCES	3
OTHER POWER SOURCES.....	3
DESIGN FEATURES.....	3
INSTALLATION	SECTION A
LOCATION	A-1
TECHNICAL SPECIFICATIONS	A-2
RECOMMENDED ELECTRODE AND WORK CABLE SIZES FOR ARC WELDING	A-3
TRIGGER CONNECTOR.....	A-3
PROCEDURE TO INSTALL DRIVE ROLLS AND WIRE GUIDES	A-4
PRESSURE ARM ADJUSTMENT.....	A-4
CHANGING THE GUN ADAPTER BUSHING	A-5
GUN CONNECTION.....	A-6
SHIELDING GAS CONNECTION	A-6
OPERATION	SECTION B
POWER-UP SEQUENCE	B-1
CONNECTION DIAGRAM.....	B-2
DEFINITION OF WELDING TERMS.....	B-3
ACROSS THE ARC SETUP WITH CROSSLINC™	B-2
DIGITAL METER DISPLAY	B-4
STEEL AND STAINLESS SYNERGIC GMAW-P.....	B-5
DIGITAL METER OPERATION	B-6
WELDING MODES.....	B-7
MEMORIES.....	B-7
SETTINGS MENU.....	B-8
SETUP MENU.....	B-9
ADVANCED.....	B-10
CASE FRONT CONTROLS	B-11
INTERNAL CONTROLS	B-12
REAR CONTROLS	B-13
OPTIONS/ACCESSORIES.....	SECTION C
MAINTENANCE	SECTION D
ROUTINE MAINTENANCE	D-1
PERIODIC MAINTENANCE	D-1
TROUBLESHOOTING	SECTION E
DIAGRAMS	SECTION F
PARTS LIST	PARTS.LINCOLNELECTRIC.COM

CONTENT/DETAILS MAY BE CHANGED OR UPDATED WITHOUT NOTICE. FOR MOST CURRENT INSTRUCTION MANUALS, GO TO PARTS.LINCOLNELECTRIC.COM.

GENERAL DESCRIPTION

The Activ8X Pipe is a rugged, portable, across-the-arc wire feeder with CrossLinc. The Activ8X Pipe has been designed for use in field welding cross-country pipelines and process pipe. Tie-ins and pump stations are areas where fully automatic welding cannot be easily applied and semi-automatic wire welding is advantageous. Process pipe is typically 3xx series carbon, stainless, and chromoly and requires field portability of the wire feeder. With its 8 in. spool, the Activ8X is specifically designed to be lightweight and portable.

The Activ8X Pipe comes factory equipped with a K1500-2 Magnum® Tweco-compatible style #2-#4 gun adapter. Other K1500 series gun adapters are available as field installed options.

In addition to CrossLinc, the Activ8X Pipe wire feeder has the following features:

- Rating- 250 amp, 100% duty cycle rating (275 amp at 60%).
- Gas apparatus – can be used for FCAW-G and GMAW processes.
- The plastic case is molded from a high impact, flame retardant plastic for high durability and low weight.
- The heart of the Activ8X Pipe is the 2 roll MAXTRAC® drive. The patented features on the wire drive offer tool-less changing of the drive rolls and wire guides for quick spool changes. A tachometer controlled motor powers the patented drive rolls for smooth, steady feeding without slippage.

RECOMMENDED PROCESSES

- GMAW
- FCAW

PROCESS LIMITATIONS

- Not recommended for stitch, spot welding or DC- processes.

EQUIPMENT LIMITATIONS

RECOMMENDED POWER SOURCES

- Flextec 350X Power Connect (code 13181 and above)

OTHER POWER SOURCES

- Frontier 400X

DESIGN FEATURES

Loaded with Standard Features Controls

- Digital Displays with large voltage and wire feed speed knobs.
- Electronic Trigger interlock for comfort when making long welds.
- Cold-feed switch for wire feeding without activating welding output.
- Gas Purge switch for purging the gas path without activating welding output.
- The following options are available from the setup menu:
 - Variable run-in for smoother arc starting.
 - Burnback time provides adjustable power source output shutoff to prevent the electrode from sticking in the crater.
 - Preflow and Postflow ensures proper gas shielding coverage before and after each weld.

READ ENTIRE INSTALLATION SECTION BEFORE
INSTALLING THE ACTIV8X PIPE .

INSTALLATION

WARNING

ELECTRIC SHOCK CAN KILL.

- Turn the input power OFF at the disconnect switch or fuse box before attempting to connect or disconnect input power lines, output cables or control cables.
- Only qualified personnel should perform this installation.
- Do not touch metal portions of the Activ8X work clip when the welding power source is on.
- Do not attach the work clip to the wire feeder.
- Connect the work clip directly to the work, as close as possible to the welding arc.
- Turn power off at the welding power source before disconnecting the work clip from the work.
- Only use with recommended power sources with open circuit voltages less than 110 VDC.



SELECT SUITABLE LOCATION

For best wire feeding performance, place the Activ8X Pipe on a stable and dry surface. Keep the wire feeder in a vertical position. Do not operate the wire feeder on an angled surface of more than 15 degrees.

Do not submerge the Activ8X Pipe.

The Activ8X Pipe is rated IP23 and is suitable for outdoor use.

The handle of the Activ8X Pipe is intended for moving the wire feeder about the work place only.

When suspending a wire feeder, insulate the hanging device from the wire feeder enclosure.

CAUTION

High Frequency Interference Protection

Locate the Activ8X Pipe away from radio controlled machinery. The normal operation of the Activ8X Pipe may adversely affect the operation of RF controlled equipment, which may result in bodily injury or damage to the equipment.

TECHNICAL SPECIFICATIONS -

MODEL SUMMARY				
K#	Description	Meters	Drive Roll Kit Included	Feed Plate Gun Adapter Installed
K4717-1	Activ8X Pipe	DIGITAL	.035/.045	K1500-2
K5240-1	Activ8X Pipe CE		(.90/1.2)	

INPUT - SINGLE PHASE	
Input Voltage +/- 10%	Input Amperes @ Rated Output
60 - 90V DC	83 - 134A
RATED OUTPUT (ALL MODELS)	
Duty Cycle	Amperes
100%	250A
60%	275A

PHYSICAL DIMENSIONS				
Model	Height	Width	Depth	Weight
K4717-1	19.54 in	8.14 in	21.02 in	49.5 lbs
K5240-1	(496 mm)	(207 mm)	(534 mm)	(22.45 kg)

TEMPERATURE RANGES	
OPERATING TEMPERATURE RANGE	STORAGE TEMPERATURE RANGE
-14°F to 104°F (-10°C to 40°C)	-40°F to 122°F (-40°C to 50°C)

Thermal tests have been performed at ambient temperature. The duty cycle (duty factor) at 40°C has been determined by simulation.

Process	Wire Diameter Range	Wire Feed Speed Range
GMAW	0.023 - 0.052" (0.6 - 1.3mm)	50 - 700 IPM (1.3 - 20.3 m/minute)
FCAW	0.035 - 5/64" (0.9 - 2.0mm)	

RECOMMENDED ELECTRODE AND WORK CABLE SIZES FOR ARC WELDING

(See Table A.1)

Tabulated below are copper cable sizes recommended for different currents and duty cycles. Lengths stipulated are the distance from the welder through work and back to the welder again. Cable sizes are increased for greater lengths primarily for the purpose of minimizing cable drop.

TABLE A.1

RECOMMENDED CABLE SIZES (RUBBER COVERED COPPER - RATED 167°F OR 75°C)**						
Amperes	PERCENT DUTY CYCLE	CABLE SIZES FOR COMBINED LENGTHS OF ELECTRODE AND WORK CABLES				
		0 to 50Ft. (0 to15m)	50 to 100Ft. (15 to 30m)	100 to 150 Ft. (30 to 46m)	150 to 200 Ft. (46 to 61m)	200 to 250 Ft. (61 to 76m)
200	60	2	2	2	1	1/0
200	100	2	2	2	1	1/0
225	20	4 or 5	3	4 or 5	1	1/0
225	40 & 30	3	3	3	1	1/0
250	30	3	3	3	1	1/0
250	40	2	2	2	1	1/0
250	60	1	1	1	1	1/0
250	100	1	1	1	1	1/0
300	60	1	1	1	1/0	1/0
350	100	2/0	2/0	2/0	2/0	2/0
350	60	1/0	1/0	1/0	2/0	3/0
400	60	2/0	2/0	2/0	3/0	4/0
400	100	3/0	3/0	3/0	3/0	4/0
500	60	2/0	2/0	2/0	3/0	4/0

** Tabled values are for operation at ambient temperatures of 104°F(40°C) and below. Applications above 104°F(40°C) may require cables larger than recommended, or cables rated higher than 167°F(75°C).

TRIGGER CONNECTOR

There is one circular connector for the gun trigger on the front of the Activ8X

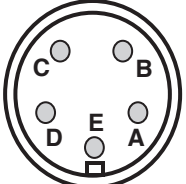
Picture	Function	Pin	Wiring
	5 PIN TRIGGER CONNECTOR FOR PUSH-ONLY GUNS.	A	15 VOLT SUPPLY
		B	NOT USED
		C	TRIGGER
		D	83% WFS SWITCH
		E	15 VOLT SUPPLY

⚠ WARNING

ELECTRIC SHOCK CAN KILL.

- Do not touch electrically live parts.



PROCEDURE TO INSTALL DRIVE ROLLS AND WIRE GUIDES

⚠ WARNING

ELECTRIC SHOCK CAN KILL.

- Turn the input power OFF at the welding power source before installation or changing drive rolls and/or guides.
- Do not touch electrically live parts.
- When inching with the gun trigger, electrode and drive mechanism are "hot" to work and ground and could remain energized several seconds after the gun trigger is released.
- Do not operate with covers, panels or guards removed or open.
- Only qualified personnel should perform maintenance work.



PRESSURE ARM ADJUSTMENT

⚠ WARNING

ELECTRIC SHOCK CAN KILL.

- Turn the input power OFF at the welding power source before installation or changing drive rolls and/or guides.
- Do not touch electrically live parts.
- When inching with the gun trigger, electrode and drive mechanism are "hot" to work and ground and could remain energized several seconds after the gun trigger is released.
- Do not operate with covers, panels or guards removed or open.
- Only qualified personnel should perform maintenance work.



1. Turn power off at the welding power source.
2. Release the idle roll pressure arm.
3. Remove the outer wire guide by turning the knurled thumbscrews counter-clockwise to unscrew them from the feedplate.
4. Rotate the locking hub lock and remove the drive rolls.

The pressure arm controls the amount of force the drive rolls exert on the wire. Proper adjustment of the pressure arm gives the best welding performance.

Set the pressure arm as follows:

FIGURE A.3

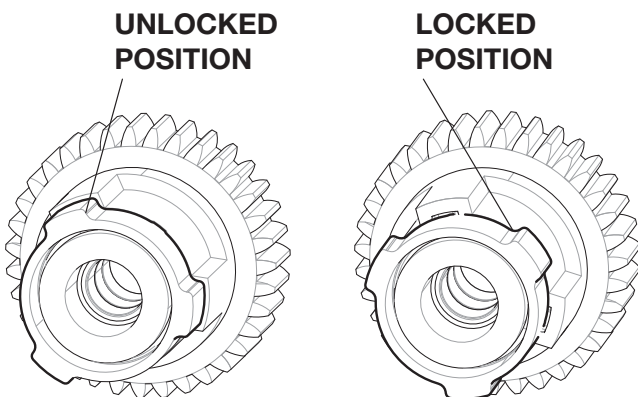

Aluminum wires	between 1 and 3
Cored wires	between 3 and 4
Steel, Stainless wires	between 4 and 6

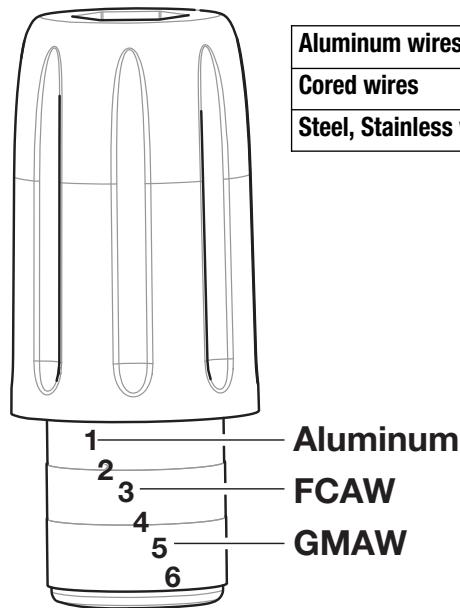

5. Remove the inner wire guide.
6. Insert the new inner wire guide, groove side out, over the two locating pins in the feedplate.
7. Install a drive roll on each hub assembly secure with the locking hub.
8. Install the outer wire guide by aligning it with the pins and tightening the knurled thumbscrews.
9. Close the idle arm and engage the idle roll pressure arm. Adjust the pressure appropriately.

CHANGING THE GUN ADAPTER BUSHING

⚠ WARNING

ELECTRIC SHOCK CAN KILL.

- Turn the input power OFF at the welding power source before installation or changing drive rolls and/or guides.
- Do not touch electrically live parts.
- When inching with the gun trigger, electrode and drive mechanism are "hot" to work and ground and could remain energized several seconds after the gun trigger is released.
- Do not operate with covers, panels or guards removed or open.
- Only qualified personnel should perform maintenance work.



Tools required:

- ¼" hex key wrench

Note: Some gun adapters do not require the use of the thumb screw.

1. Turn power off at the welding power source.
2. Remove the welding wire from the wire drive.
3. Remove the thumb screw from the wire drive.
4. Remove the welding gun from the wire drive.
5. Loosen the socket head cap screw that holds the connector bar against the gun adapter. Important: **Do not attempt to completely remove the socket head cap screw.**
6. Remove the outer wire guide, and push the gun adapter out of the wire drive. Because of the precision fit, light tapping may be required to remove the gun bushing.
7. Disconnect the shielding gas hose from the gun bushing, if required.
8. Connect the shielding gas hose to the new gun adapter, if required.
9. Rotate the gun adapter until the thumb screw hole aligns with the thumb screw hole in the feedplate. Slide the gun receiver bushing into the wire drive and verify the thumb screw holes are aligned.
10. Tighten the socket head cap screw.
11. Insert the welding gun into the gun adapter and tighten the thumb screw.

FIGURE A.2

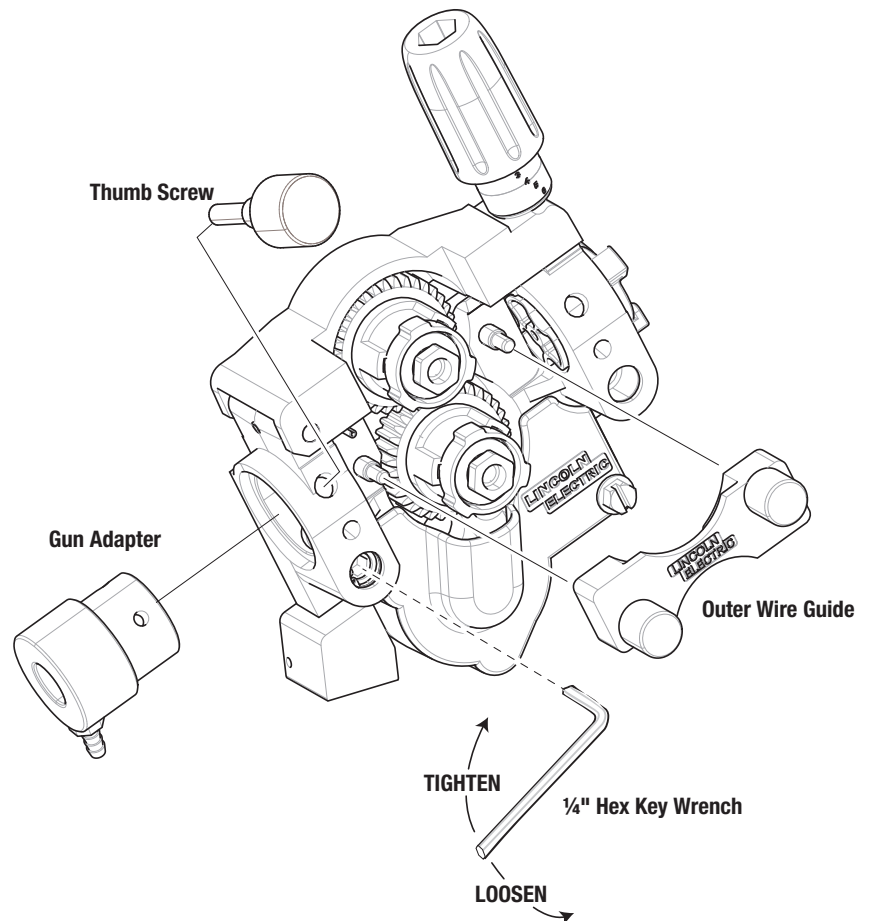

GUN CONNECTION**⚠ WARNING****ELECTRIC SHOCK CAN KILL.**

- Turn the input power OFF at the welding power source before installation or changing drive rolls and/or guides.
- Do not touch electrically live parts.
- When inching with the gun trigger, electrode and drive mechanism are "hot" to work and ground and could remain energized several seconds after the gun trigger is released.
- Do not operate with covers, panels or guards removed or open.
- Only qualified personnel should perform maintenance work.



The Activ8X® Pipe comes with a K1500-2 gun adapter installed, this accepts #2 - #4 guns. To install a gun:

1. Turn power OFF at the welding power source.
2. Remove the thumb screw.
3. Push the gun the completely into the gun bushing.
4. Secure the gun in place with the thumb screw.
5. Connect the trigger cable from the gun to the trigger connector on the front of the feeder.

Note: Not all gun bushings require the use of the thumb screw.

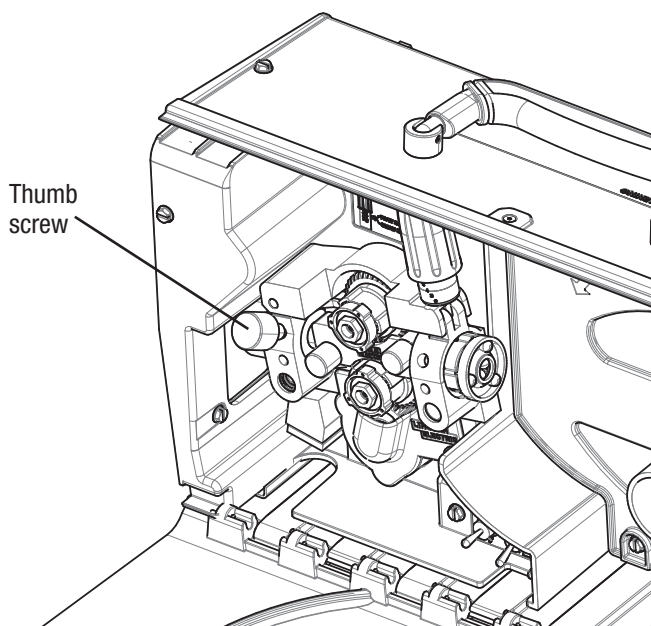
**SHIELDING GAS CONNECTION****⚠ WARNING****CYLINDER may explode if damaged.**

- Keep cylinder upright and chained to support.
- Keep cylinder away from areas where it may be damaged.
- Never lift welder with cylinder attached.
- Never allow welding electrode to touch cylinder.
- Keep cylinder away from welding or other live electrical circuits.

**Build up of shielding gas may harm health or kill.**

- Shut off shielding gas supply when not in use.
- See American National Standard Z-49.1, "Safety in Welding and Cutting" Published by the American Welding Society.

**Maximum inlet pressure is 100 psi. (6.9 bar.)**

Install the shielding gas supply as follows:

1. Secure the cylinder to prevent it from falling.
2. Remove the cylinder cap. Inspect the cylinder valves and regulator for damaged threads, dirt, dust, oil or grease. Remove dust and dirt with a clean cloth. **DO NOT ATTACH THE REGULATOR IF OIL, GREASE OR DAMAGE IS PRESENT!** Inform your gas supplier of this condition. Oil or grease in the presence of high pressure oxygen is explosive.
3. Stand to one side away from the outlet and open the cylinder valve for an instant. This blows away any dust or dirt which may have accumulated in the valve outlet.
4. Attach the flow regulator to the cylinder valve and tighten the union nut(s) securely with a wrench. Note: if connecting to 100% CO₂ cylinder, insert regulator adapter between regulator and cylinder valve. If adapter is equipped with a plastic washer, be sure it is seated for connection to the CO₂ cylinder.
5. Attach one end of the inlet hose to the outlet fitting of the flow regulator. Attach the other end to the welding system shielding gas inlet. Tighten the union nuts with a wrench.
6. Before opening the cylinder valve, turn the regulator adjusting knob counterclockwise until the adjusting spring pressure is released.
7. Standing to one side, open the cylinder valve slowly a fraction of a turn. When the cylinder pressure gage stops moving, open the valve fully.
8. The flow regulator is adjustable. Adjust it to the flow rate recommended for the procedure and process being used before making a weld.

OPERATION

SAFETY PRECAUTIONS

WARNING

ELECTRIC SHOCK can kill.

- Do not touch electrically live parts or electrode with skin or wet clothing.
- Insulate yourself from work and ground.
- Always wear dry insulating gloves.



FUMES AND GASES can be dangerous.

- Keep your head out of fumes.
- Use ventilation or exhaust to remove fumes from breathing zone.



ARC RAYS can burn.

- Wear eye, ear and body protection.











Observe additional Safety Guidelines detailed in the beginning of this manual.

The serviceability of a product or structure utilizing the Activ8X PIPE wirefeeder is and must be the sole responsibility of the builder/user. Many variables beyond the control of The Lincoln Electric Company affect the results obtained in using the Activ8X PIPE wirefeeder. These variables include, but are not limited to, welding procedure, plate chemistry and temperature, weldment design, fabrication methods and service requirements. The available range of the Activ8X wirefeeder may not be suitable for all applications, and the builder/user is and must be solely responsible for welding settings.

POWER-UP SEQUENCE

If the gun trigger is activated during power up, the feeder will not operate until the gun trigger is released.

GRAPHIC SYMBOLS THAT APPEAR ON THIS MACHINE OR IN THIS MANUAL

-  **WARNING OR CAUTION**
-  **INPUT VOLTAGE**
-  **OUTPUT ON**
-  **GAS PURGE**
-  **HIGH TEMPERATURE**
-  **READ INSTRUCTION MANUAL**
-  **PROTECTIVE GROUND**
-  **GAS INPUT**
-  **SINGLE PHASE**

ACROSS THE ARC SET-UP WITH CROSSLINC (RECOMMENDED)

With the power source in Stick, CV-Gas or CV-Innershield, place the Local/Remote switch in the Remote position. In many newer models of CrossLinc compatible power sources, the Local/Remote switch is automatically overridden by CrossLinc and there is no need to set it.

Item	K#	Description
1*	K4717-1	Activ8X® Pipe™ (Tweco)
	K4273-1	K4273-1 Flextec 350X Power Connect (Tweco)
2	KP1696-1	Drive Roll Kit
3	K4531-2-10-45	Welding Gun
4	K2484-2	Work Cable
5	K910-2	Work Clamp
6	K2485-2	Weld Power Cable

*CE Version

Item	K#	Description
1	K5240-1	Activ8X® Pipe CE™ (Dinse)
	K5422-1	K5422-1 Flextec 350XP CE

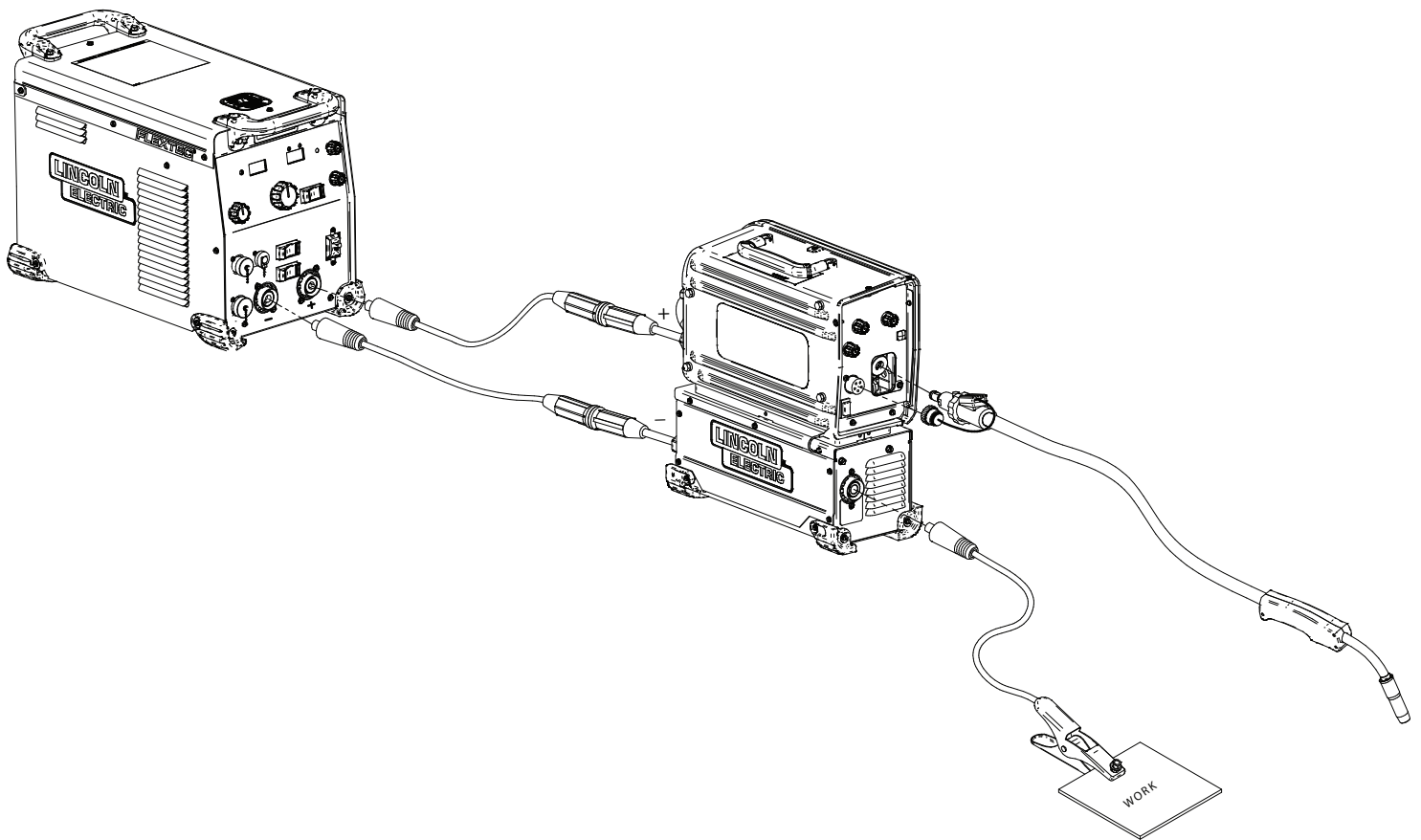

DEFINITION OF WELDING TERMS

NON-SYNERGIC WELDING MODES

- A Non-synergic welding mode requires all welding process variables to be set by the operator.

SYNERGIC WELDING MODES

- A Synergic welding mode offers the simplicity of single knob control. The machine will select the correct voltage and amperage based on the wire feed speed (WFS) set by the operator.

WFS

- Wire Feed Speed

CC

- Constant Current

CV

- Constant Voltage

GMAW

- Gas Metal Arc Welding

GMAW-P

- Gas Metal Arc Welding-(Pulse Arc)

GMAW-STT

- Gas Metal Arc Welding-(Surface Tension Transfer)

SMAW

- Shielded Metal Arc Welding

GTAW

- Gas Tungsten Arc Welding

FCAW

- Flux Core Arc Welding

CAG

- Carbon Arc Gouging

Digital Meter Displays

While Idle:

The left display shows the preset wire feed speed. The right display shows the preset voltage when it is connected to a compatible power source.

While Welding:

The value in the left display will be either amps or actual wire feed speed, depending upon the selection chosen in the set-up menu. The corresponding LED on the sides of the display will light. For non-synergic welding modes, the right display will show actual voltage.

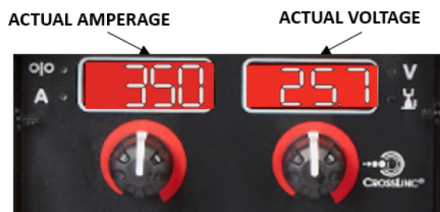

FIGURE B.1

VOLTAGE DISPLAY IN NON-SYNERGIC WELDING

The voltage display is determined by the welding mode. For non-synergic welding modes, the right display will show actual voltage.

VOLTAGE DISPLAY IN SYNERGIC WELDING

For synergic CV modes, the right display will show trim. When the right knob is rotated, the display will show an upper or lower bar if the voltage is above or below the ideal voltage



FIGURE B.2

Preset voltage above ideal (lower bar displayed for 1 second).



FIGURE B.3

Preset voltage is ideal.



FIGURE B.4

Preset voltage below ideal (lower bar displayed for 1 second).

Note: Changing the WFS will result in the preset voltage following the set wire feed speed as a synergic setting.

SYNERGIC PULSE

Pulse welding controls the arc length with "Trim" instead of voltage. When trim (arc length is adjusted with the knob, the machine automatically recalculates the voltage, current and time of each part of the pulse waveform for the best result. Trim adjusts the arc length and ranges from 0.50 to 1.50.

Note: the Trim display can be changed back to showing volts in the set-up menu.

STEEL AND STAINLESS SYNERGIC GMAW-P (PULSED MIG) WELDING

Synergic GMAW-P (Pulsed MIG) welding is ideal for low spatter, out of position and reduced heat input applications. During pulse welding, the welding current continuously switches from a low level to a high level and then back again. Each pulse sends a small droplet of molten metal from the wire to the weld puddle.

Pulse welding controls the arc length with 'Trim' instead of voltage. When trim (arc length) is adjusted, the Power Wave automatically recalculates the voltage, current and time of each part of the pulse waveform for the best result. Trim adjusts the arc length and ranges from 0.50 to 1.50. Increasing the trim value increases the arc length, while decreasing the trim value decreases the arc length. The Arc Control knob or control output equates to - Pinch / Inductance/ Arc Force / Ultimarc / pulse frequency.

FIGURE B.5

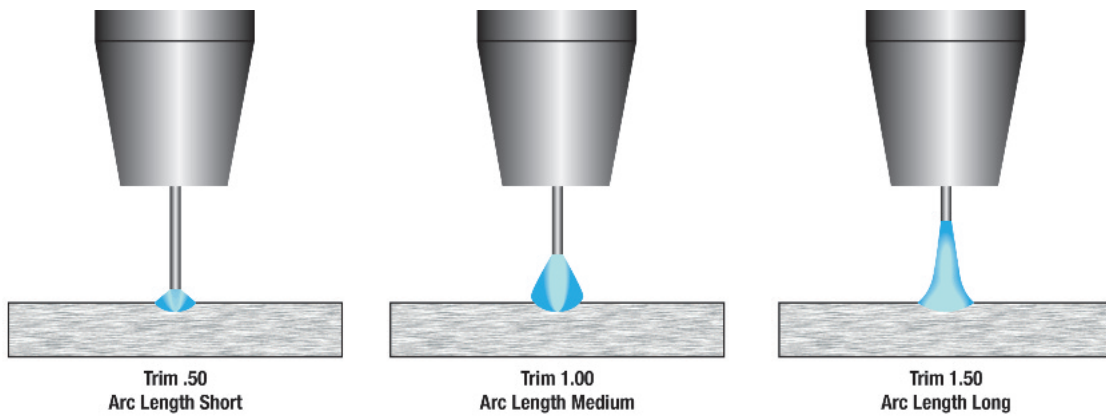

For steel and stainless pulse modes, Arc Control regulates the focus or shape of the arc. Arc Control values greater than 0.0 increase the pulse frequency while decreasing the background current, resulting in a tight, stiff arc best for high speed sheet metal welding. Arc Control values less than 0.0 decrease the pulse frequency while increasing the background current, for a soft arc good for out-of-position welding.

FIGURE B.6

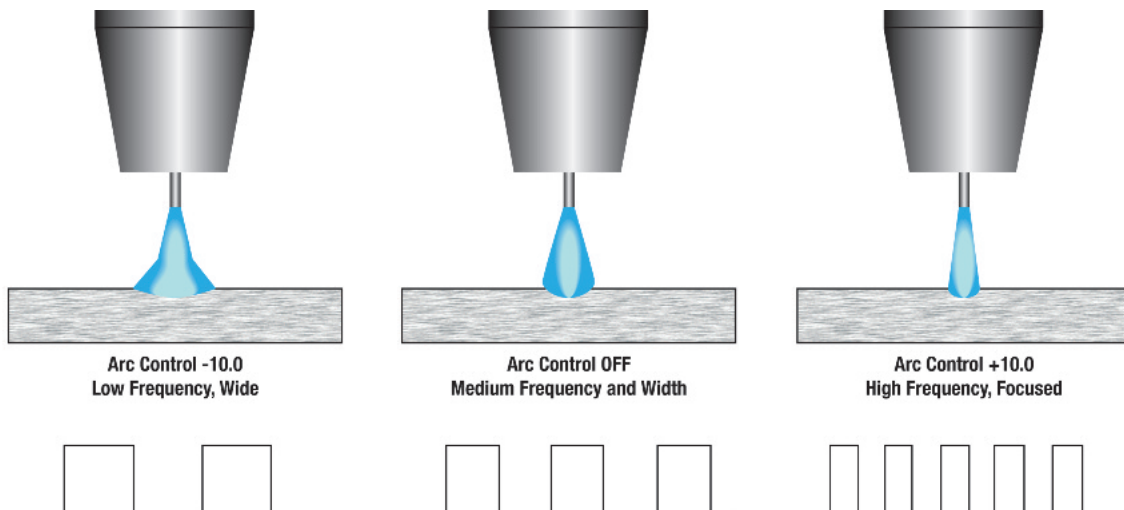

DIGITAL METER OPERATION - WHILE IDLE

The left display shows the preset wire feed speed while the right display shows the preset voltage or trim when it is connected to a power source that supports the Activ8X Pipe and CrossLinc communication has been established (see figure B.1). It will display dashes when connected to an incompatible power source (The lower display will show "CrossLinc Required")

Otherwise, the lower display will show the following welding process info:

- Process name
- Wire type
- Wire size
- Gas type
- Active memory
- Active procedure

During startup, and if enabled, the total recorded arc time will be displayed for 5 seconds.

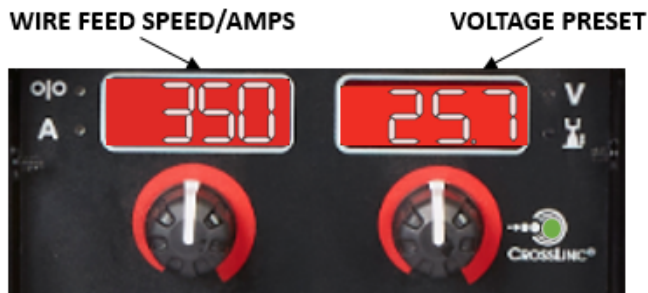

Figure B.7

DIGITAL METER OPERATION - WHILE WELDING

The left display shows amps or WFS based on the selection in the settings menu (the corresponding LED will be illuminated). The right display shows Voltage or Trim, depending on the weather the welding mode is synergic or non-synergic (the corresponding LED will be illuminated).

DIGITAL METER OPERATION - AFTER WELDING

The display continues to hold the value of the amperage or WFS and arc voltage for five seconds after the completion of each weld. The corresponding LEDs (for amperage/WFS or Voltage/Trim will flash at a 1 second rate to identify these as "Look back" values. Turning any of the 3 knobs will cause the displays to show preset information.

TRUE ENERGY

If True Energy display is enabled, the bottom display will show the accumulated energy in kilo joules (KJ) and arc time in seconds for the duration of each weld. The final value for the weld will blink on and off during the 5 second hold time. The values for the energy and arc time are stored for the last 20 welds and can be accessed through the advanced setup menu.

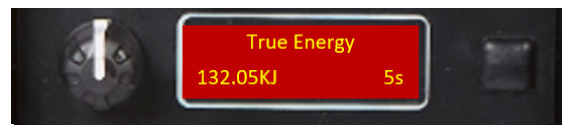

Figure B.8

WELDING MODES

Non-Synergic Welding Modes

In non-synergic weld modes, WFS and Voltage can be chosen independently of each other. There are two non-synergic modes in the Activ8X Pipe:

- Non-synergic GMAW
- Non-synergic FCAW-G

Synergic Welding Modes

In synergic weld modes, the WFS work-point is chosen and the recommended voltage/trim is given for the chosen work-point. If needed, the Voltage/Trim can be adjusted (up or down). If the Voltage/Trim is adjusted above its recommend limit, a dash will appear on the upper-left of the preset Voltage value. If the Voltage/Trim is adjusted below its recommend limit, a dash will appear on the lower-left of the preset Voltage value.

WELD PROCEDURE SETUP

WFS and Volts/Trim are chosen with the upper encoders on the Activ8X Pipe User Interface.

Weld modes are chosen with the lower encoder and displayed on the lower screen.

AUTO SETTINGS

The Activ8X Pipe has an Auto settings feature enabled by default. Auto settings are engineered by Lincoln and vary based on the workpoint of the weld mode and help optimize the welding performance. Auto settings are enabled by default for the following parameters:

- Preflow
- Run-in
- Start procedure
- Crater procedure
- Burnback
- Postflow

Auto settings are enabled on these parameters by default but can be disabled, allowing the parameters to be manually set by the end-user.

MEMORIES

There are four memory storage selections. The active memory is shown in the lower right corner of the bottom display.

If the memory number is blinking, then the active procedure has a setting that does not exactly match the settings stored in that memory.

Pressing the right pushbutton allows you to cycle through and make active any of the 4 memories stored in the Activ8X Pipe®.

After 5 seconds of inactivity (or immediately following a gun trigger, gas purge or cold feed switch engagement), the "M" in the upper right corner will disappear indicating that the memory selection menu has been exited. The number of the selected memory will continue to be displayed in the lower right corner of the bottom display. If changes are made to the settings outside of memory selection, the number will blink.

To save the active procedure settings to a memory, press and hold the right button for 3 seconds. After the memory is stored, the display will indicate the stored memory location. The display will stay on for 2 seconds and then the display will revert to the memory selection display.

All four memory locations and procedure A and B will default to the factory default settings after a factory reset.

Memory saves can be disabled in the setup menu.



FIGURE B.9

SETTINGS MENU

There are 3 levels of menus that can be accessed on the AX8P: process-related settings, feeder settings, and advanced settings

- Settings Menu (welding process related)
- Setup Menu (Determines how the UI displays info)
- Advanced Setup Menu (Factory info and diagnostics)

Settings Menu:

To enter the welding menu system, press and hold the bottom knob pushbutton for at least .5 seconds.

Within settings, rotating the knob will cycle through the "Settings menu" items.

A press of the left push button will select the welding menu item that is blinking. After the press, the parameter value to be set will blink.

Rotating the bottom encoder knob will change the selected value.

Pressing the bottom encoder push button again will store the value that has been set.

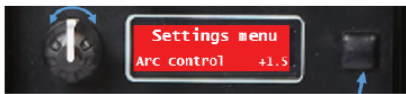

FIGURE B.10

Settings Menu items are:

- Arc Control
- Run-in Speed (as a % of welding WFS)
- Preflow Time
- Postflow Time
- Burnback Time
- Start Settings
- Crater Settings
- Setup Menu

Starting Procedure

Starting procedure has a factory default setting of Auto. If desired, a custom Starting routine can be set. If active, the Activ8X Pipe will strike the arc with the set WFS and Voltage and then ramp over the set amount of time to the welding WFS and Voltage.

A short press of the bottom encoder push button will select the menu item that is blinking ("Start"). After the press, the values to be set will blink on the upper seven-segment displays and the right-hand side of the lower alphanumeric display. Rotations the upper left encoder knob will set the start wire feed speed.

Rotating the upper right encoder knob will set the start volts setting. It will be ignored for synergic weld modes that will automatically calculate the nominal settings based on the wire feed speed.

These settings are unaffected by limits settings.

Start time can be set to a time in seconds. The available settings are OFF to 10s in increments of 1 second.



FIGURE B.11

Crater / Ending Procedure:

Crater / Ending procedure has a factory default setting of Auto. If desired, a custom Crater routine can be set. If active, the Activ8X Pipe will ramp up or down from the welding WFS and Voltage to the Crater WFS and Voltage over the set amount of time.

A short press of the bottom encoder push button will select the menu item that is blinking ("Crater"). After the press, the values to be set will blink on the upper seven-segment displays and the right-hand side of the lower alphanumeric display.

Rotating the upper left encoder knob will set the crater wire feed speed. Rotating the upper right encoder knob will set the crater volts setting.

These settings are unaffected by limits settings.

Crater time can be set to a time in seconds. The available settings are OFF to 10s in increments of 1 second.

Setup Menu:

From the Settings Menu, and when "Enter Setup Menu" is displayed (and blinking) pressing the bottom encoder push button will enter the setup menu.

A press of the right push button exits the setup menu and returns to the top of the settings menu.

A short press of the bottom encoder push button will select the menu item that is blinking. After the press, the value to be set will blink.

Rotating the bottom encoder knob will change the selected value.

Pressing the bottom encoder push button again will store the value that has been set.

The "Setup Menu" items are:

- True Energy Logs
- True Energy Display Setting (default = disabled)
- Metric/Imperial WFS display settings (default = imperial)*
- Arc Current or Actual WFS display during welding (default = Arc Current)
- Trigger selection of memories (default = disabled)
- WFS Limits (default = disabled)
- Volts Limits (default = disabled)
- Arc control Limits (default = disabled)
- Trim Display Setting in Trim versus Volts Display Setting (default = trim)
- Process Selection Lockout (default = unlocked)
- Number of Memories (default = 4)
- Memory Save Enable (default = enabled)

*WFS display settings default = metric on CE Version

Setting High Limits:

A short press of the bottom encoder push button will select the menu item that is blinking ("High Limits"). After the press, the values to be set will blink on the upper seven-segment displays. Rotating the upper left and right encoder knobs will set the high limits for the units indicated by the LEDs to the left and right of the upper displays. These settings will be those associated with the active procedure.

To disable any of the limits, turn the associated encoder clockwise until the display shows "OFF".

The values will be set as they are adjusted.

The limits settings are stored independently for each memory location.



Setting Low Limits:

A short press of the bottom encoder push button will select the menu item that is blinking ("High Limits"). After the press, the values to be set will blink on the upper seven-segment displays. Rotating the upper left and right encoder knobs will set the high limits for the units indicated by the LEDs to the left and right of the upper displays. These settings will be those associated with the active procedure.

To disable any of the limits, turn the associated encoder clockwise until the display shows "OFF".

The values will be set as they are adjusted.

The limits settings are stored independently for each memory location.



Advanced Setup Menu

The Advanced Setup menu can be entered by pressing the bottom encoder push button and the bottom right "memory" push button simultaneously for 5 seconds when not in the menu system or welding.

A press of the right push button exits the advanced setup menu.

The "Advanced Setup Menu" items are:

- Wire Feed Speed Calibration* (default = 1.00)
- Password Setting/Enable (default = disabled)
- Software Versions
- Factory Reset
- Arc Time Display Enable (default = off)
- Test modes Enable
- Current Calibration
- Voltage Calibration
- System Test

CASE FRONT CONTROLS

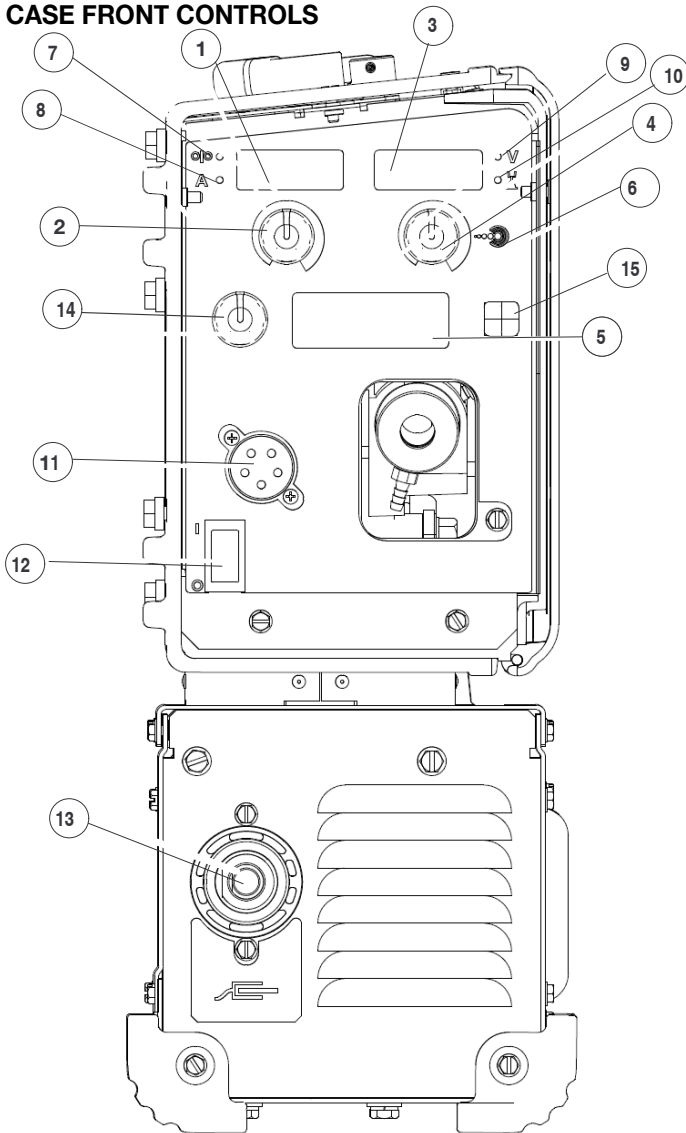

1. **Wire Feed Speed Digital Display** - The Activ8X has a digital display that shows the wire feed speed. This display is also capable of displaying amperage and the setup menu.
2. **Wire Feed Speed Knob** - Use the Wire Feed Speed Knob to set the rate of wire feed speed. The wire feed speed will be displayed on the Wire Feed Speed Digital Display. During CV operation, the wire feed speed will remain a constant value, independent of arc voltage changes, as long as the arc voltage does not drop below the values per the following table.
3. **Voltage Digital Display** - The Activ8X has a digital display that shows the voltage between electrode and work
4. **Voltage/Trim Knob** - Use the Voltage Knob to set the voltage when connected to a CrossLinc™ Power Source. The voltage will be displayed on the Voltage Digital Display. During CV operation, the voltage will remain stable while welding.
5. **Alphanumeric Display** - Shows wire type, wire size, process name, gas type, active procedure and active memory. This display is also capable of displaying settings menu parameters.
6. **CrossLinc™ LED** - The CrossLinc LED displays whether the feeder is connected to a CrossLinc compatible power source. When the feeder has successfully connected to the power source, the LED will illuminate.
7. **Wire Feed Speed LED** - The Wire Feed Speed and Amperage LEDs will communicate what is being displayed on the Wire Feed Speed Digital Display. When the Wire Feed Speed LED is illuminated, wire feed speed is being displayed.
8. **Amperage LED** - When the Amperage LED is illuminated, amperage is being displayed.
9. **Voltage LED** - The Voltage LED will be illuminated when the Voltage Digital Display is displaying actual voltage.
10. **Trim LED** - When the Trim LED is illuminated, a Trim value is being displayed.
11. **Five Pin Gun Trigger Connector** - The 5 Pin Gun Trigger Connector is where the trigger that is attached to the welding gun is connected. This will actuate the welding current when the trigger is pulled.
12. **On/Off Switch**- Enables/Disables power to the Acti8X Pipe. It does not control the power to the welding power source.
13. **Work Clamp Connection**
14. **Menu Selection and Adjustment** - Push for a half second to enter the menu screens, turn knob to display the memory options. Push the knob again to confirm menu selection/
15. **Memory Button** - Push to select between 4 memory locations. Push and hold to save the active weld schedule. The memory button also serves as an exit button while in the menu screen.

INTERNAL CONTROLS

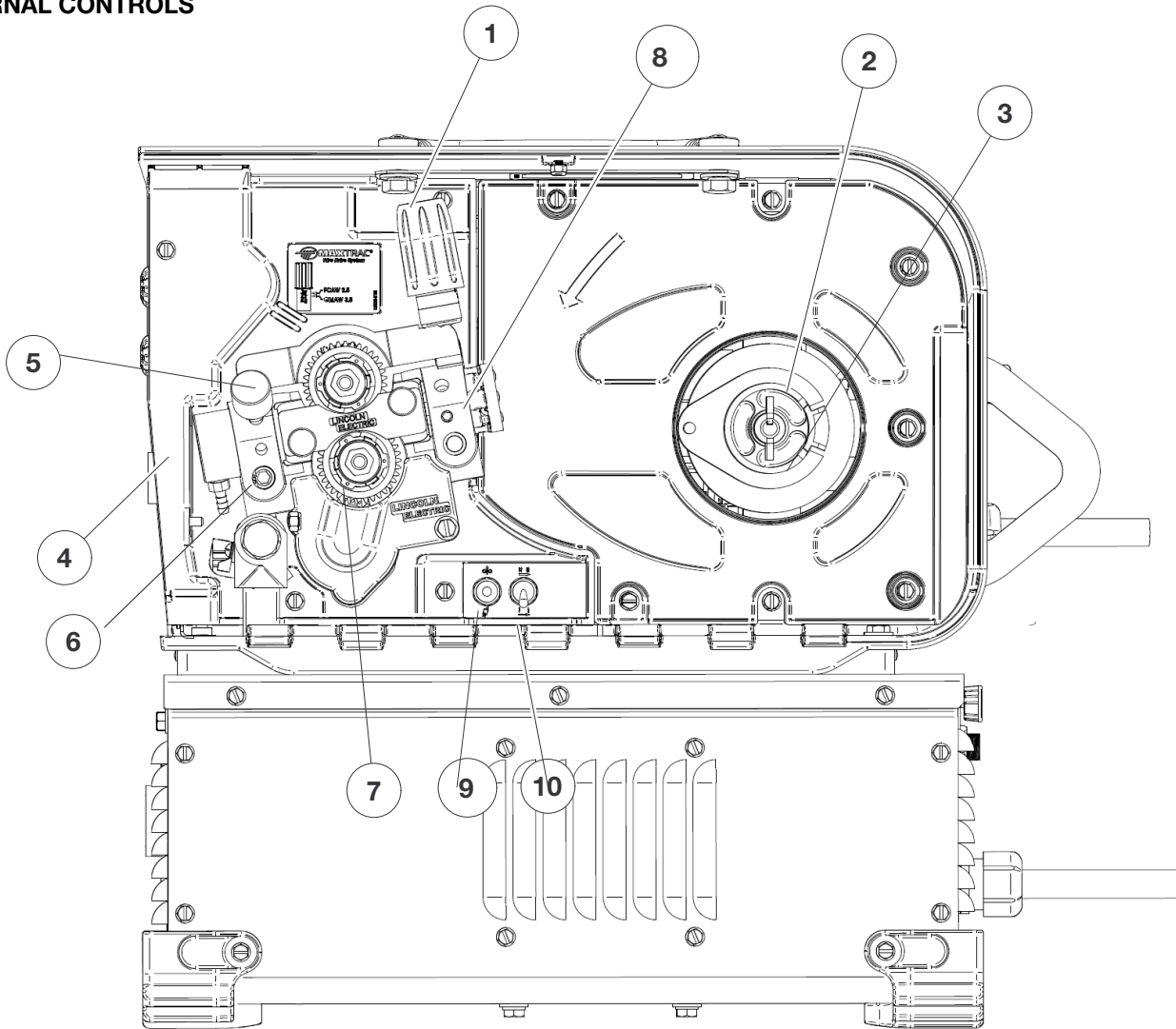

1. **Pressure Arm Adjustment Knob**
2. **Spool Retainer**
3. **Spindle Brake**
4. **Gun Bushing**
5. **Thumb Screw**
6. **Socket Head Cap Screw for Gun Bushing**
7. **Drive Hubs**
8. **Inlet Wire Guide**
9. **COLD FEED / GAS PURGE SWITCH** - Place the toggle (momentary) switch in the UP position for cold feeding, or in the DOWN position for gas purge. When cold feeding, the wire drive will feed electrode but neither the feedplate nor the gas solenoid will be energized. Adjust the speed of cold feeding by rotating the WFS knob. Cold feeding, or "cold inching" the electrode is useful for threading the electrode through the gun. When gas purging, the gas solenoid valve will energize but neither the power source output nor the drive motor will be turned on. The Gas Purge switch is useful for setting the proper flow rate of shielding gas.

10. 2 Step - Trigger Interlock Switch - The 2 Step - Trigger

Interlock switch changes the function of the gun trigger. 2 Step trigger operation turns welding on and off in direct response to the trigger. Trigger Interlock operation allows welding to continue when the trigger is released for comfort on long welds.

Place the toggle switch in the DOWN position for 2 Step operation or in the UP position for Trigger Interlock operation.

2 Step Trigger - 2 Step trigger operation is the most common. When the gun trigger is pulled, the welding power source energizes the electrode output and the wire feeder feeds wire for welding. The power source and wire feeder continue welding until the trigger is released.

Trigger Interlock - Trigger Interlock operation provides for operator comfort when making long welds. When the gun trigger is first pulled, the welding power source energizes the output and the wire feeder feeds wire for welding. The gun trigger is then released while the weld is made. To stop welding, the gun trigger is pulled again, and when it is released the welding power source output turns off and the wire feeder stops feeding wire.

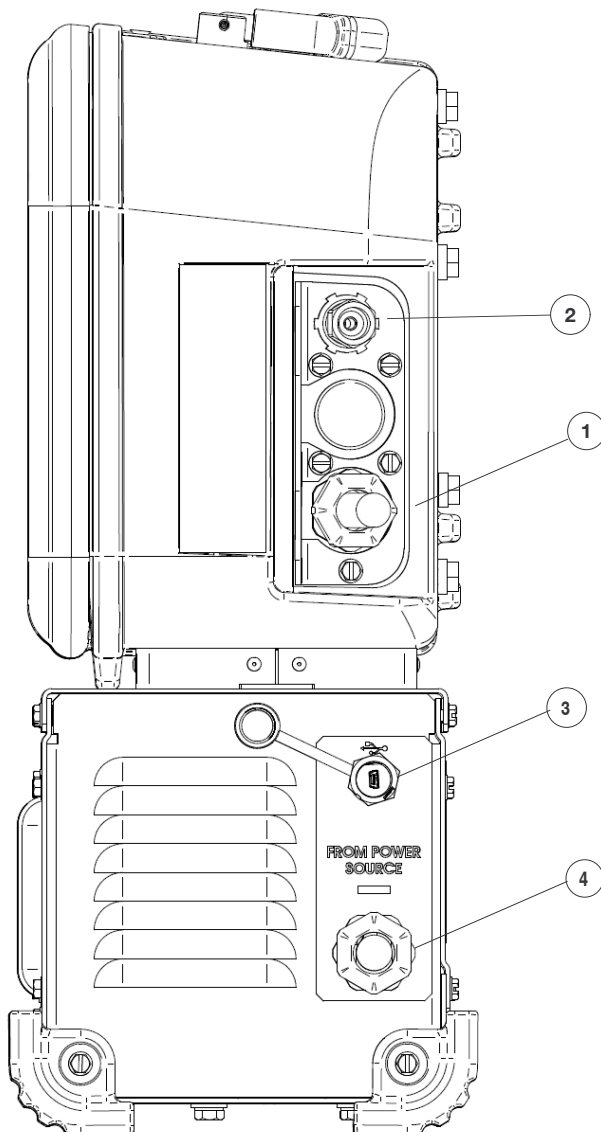
REAR CONTROLS



1. Electrode (+) Lead Connection from power source
2. Shielding Gas Inlet
3. USB Programming Port
4. Work Connection from power source

CAUTION

The serviceability of a product or structure utilizing the Activ8X Pipe wire feeder is and must be the sole responsibility of the builder/user. Many variables beyond the control of The Lincoln Electric Company affect the results obtained in using the Activ8X Pipe wire feeder. These variables include, but are not limited to, welding procedure, plate chemistry and temperature, weldment design, fabrication methods and service requirements. The available range of the Activ8X Pipe wirefeeder may not be suitable for all applications, and the builder/user is and must be solely responsible for welding settings.

OPTIONS/ACCESSORIES

The following options/accessories are available for your Activ8X Pipe from your local Lincoln Electric Distributor.

DRIVE ROLL KITS, 2 ROLL DRIVE			
Steel Wire Drive Roll Kits			
KP1696-030S	.023-.030 (0.6-0.8MM)	INCLUDES: 2 V GROOVE DRIVE ROLLS AND INNER WIRE GUIDE.	
KP1696-035S	.035 (0.9MM)		
KP1696-045S	.045 (1.2MM)		
KP1696-052S	.052 (1.4MM)		
KP1696-1/16S	1/16 (1.6MM)		
KP1696-1*	.035,.045 (0.9, 1.2MM)		
KP1696-2	.040 (1.0MM)		
Cored Wire Drive Roll Kits			
KP1697-035C	.030-.035" (0.8-0.9MM)	INCLUDES: 2 KNURLED DRIVE ROLLS AND INNER WIRE GUIDE.	
KP1697-045C	.040-.045" (1.0-1.2MM)		
KP1697-052C	.052" (1.4MM)		
KP1697-1/16C	1/16" (1.6MM)		
KP1697-068	.068-.072" (1.7-1.8MM)		
KP1697-5/64	5/64" (2.0MM)		

*Included with Activ8X Pipe

Optional Kits & Accessories

K2485-2 Weld Cable Tweco Male to Tweco Female (2/0), 50ft.

K2485-3 Weld Cable Tweco Male to Tweco Female (3/0), 50ft.

K2487-1 Lug to Tweco Female adapter.

K489-7

Feed Plate Adapter

for Lincoln Fast-Mate guns.)

Includes: Gun receiver bushing with trigger connector.



K586-1

Deluxe Adjustable Gas Regulator

Includes: Deluxe Gas Regulator for Mixed Gases, Adapter for CO2 and 10' (3.0m) Hose.



K283

Wire Feed Speed Meter

Includes: A wire feed speed meter with digital display.



K910-1 & K910-2

Work Clamp

Jaws open full 2-1/2 inches (63 mm). Welding cable lug bolts directly to the work clamp. 60% duty cycle. Select K910-1 for 300 Amp applications. K910-2 for 500 Amp.



MAINTENANCE

WARNING

ELECTRIC SHOCK CAN KILL.

- Turn the input power OFF at the welding power source before installation or changing drive rolls and/or guides.
- Do not touch electrically live parts.
- When inching with the gun trigger, electrode and drive mechanism are "hot" to work and ground and could remain energized several seconds after the gun trigger is released.
- Do not operate with covers, panels or guards removed or open.
- Only qualified personnel should perform maintenance work.



ROUTINE MAINTENANCE

- Check weld cables and gas hoses for cuts.
- Clean and tighten all weld terminals.

PERIODIC MAINTENANCE

- Clean the drive rolls and inner wire guide and replace if worn.
- Blow out or vacuum the inside of the feeder.

CURRENT CALIBRATION

1. Connect a resistive load bank to the machine configured for 245A equivalent.
2. Connect a certified calibrated current probe or current meter and shunt to the output circuit.
3. Select "Current Cal" from the advanced setup menu.
4. Selecting yes ("Y") will enable the machine output at a constant current of 245A.
5. With output enabled, the actual output current measured externally should be 245 +/- 2A. The upper displays will show what the Activ8X Pipe believes is the measurement of output voltage and output current.
6. Rotating the bottom encoder knob will increase or decrease the output current trimmer adjustment.
7. Pressing the bottom encoder push button will save the calibration data to memory and display a message for 2 seconds telling the user that the new calibration data has been saved.
8. To exit the Current Calibration procedure (with or without saving the new calibration data) the right push button can be pressed and released at any time.

CURRENT CALIBRATION COMPLETE

TO RESTORE FACTORY CURRENT CALIBRATION

1. With the Current Calibration procedure active, pressing and holding the bottom encoder push button for three seconds will reset the Current Calibration to the factory default.

TROUBLESHOOTING

WARNING

Service and Repair should only be performed by Lincoln Electric Factory Trained Personnel. Unauthorized repairs performed on this equipment may result in danger to the technician and machine operator and will invalidate your factory warranty. For your safety and to avoid Electrical Shock, please observe all safety notes and precautions detailed throughout this manual.

This Troubleshooting Guide is provided to help you locate and repair possible machine malfunctions. Simply follow the three-step procedure listed below.

Step 1. LOCATE PROBLEM (SYMPTOM).

Look under the column labeled “PROBLEM (SYMPTOMS).” This column describes possible symptoms that the machine may exhibit. Find the listing that best describes the symptom that the machine is exhibiting.

Step 2. POSSIBLE CAUSE.

The second column labeled “POSSIBLE CAUSE” lists the obvious external possibilities that may contribute to the machine symptom.

Step 3. RECOMMENDED COURSE OF ACTION

This column provides a course of action for the Possible Cause, generally it states to contact your local Lincoln Authorized Field Service Facility.

If you do not understand or are unable to perform the Recommended Course of Action safely, contact your local Lincoln Authorized Field Service Facility.



If for any reason you do not understand the test procedures or are unable to perform the tests/repairs safely, contact your Lincoln Authorized Service Facility for technical troubleshooting assistance before you proceed.

WWW.LINCOLNELECTRIC.COM/LOCATOR

Observe all Safety Guidelines detailed throughout this manual

PROBLEM	POSSIBLE CAUSE	RECOMMENDED COURSE OF ACTION
Err 81 Motor overload, long term	The wire drive motor has overheated.	<ol style="list-style-type: none"> 1. Check that the electrode slides easily through the gun and cable. 2. Remove tight bends from the gun and cable. 3. Check that the spindle brake is not too tight. 4. Verify a high quality electrode is being used. 5. Wait for the error to reset and the motor to cool (approximately 1 minute). 6. Clean/inspect/replace liner.
Err 82 Motor overload, short term	The wire drive motor current draw has exceeded limits, usually because the motor is in a locked rotor state.	<ol style="list-style-type: none"> 1. Check that motor can turn freely when idle arm is open. 2. Verify that the gears are free of debris and dirt.
Output Problems		
The feeder does power up - no voltage, no cold feed.	<ol style="list-style-type: none"> 1. The power switch is OFF 2. No output from power source. 	<ol style="list-style-type: none"> 1. Connect the work sense lead to the work in a location free of dirt, rust and paint. 2. Won't power up if power source is off.
	<ol style="list-style-type: none"> 1. . 	
No shielding gas.	<ol style="list-style-type: none"> 1. The gas supply is OFF or empty. 2. The gas hose is cut or crushed 3. Dirt or debris is in the solenoid. 4. There is a loose solenoid connection. 5. The solenoid has failed. 	<ol style="list-style-type: none"> 1. Verify the gas supply is ON and flowing. 2. Route the gas hose so it avoids sharp corners and make sure nothing is on top of it. Repair or replace damaged hoses. 3. Open the flow meter valve. 4. Apply filtered shop at 80psi to the solenoid to remove dirt. 5. Remove the cover and check that all connections are in good condition.
Inconsistent wire feeding or wire not feeding but drive rolls turning.	<ol style="list-style-type: none"> 1. The gun cable is kinked and/or twisted 2. The wire is jammed in the gun and cable. 3. The gun liner is dirty or worn. 4. The electrode is rusty or dirty. 5. The contact tip is partially melted or has spatter. 6. Improper gun liner, tip, drive 	<ol style="list-style-type: none"> 1. Keep the gun cable as straight as possible. Avoid sharp corners or bends in the cable. 2. Remove the gun from the wire feeder and pull the jammed wire out of the gun and cable. 3. Blow dirt out of the liner with low pressure (40psi or less). Replace the liner if worn. 4. Replace contact tip.



If for any reason you do not understand the test procedures or are unable to perform the tests/repairs safely, contact your Lincoln Authorized Service Facility for technical troubleshooting assistance before you proceed.

WWW.LINCOLNELECTRIC.COM/LOCATOR

Observe all Safety Guidelines detailed throughout this manual

PROBLEM	POSSIBLE CAUSE	RECOMMENDED COURSE OF ACTION
Inconsistent wire feeding or wire not feeding but drive rolls turning.	<ol style="list-style-type: none"> 6. Improper gun liner, tip, drive rolls and/or inner wire guide. 7. Incorrect tension arm pressure on the drive rolls. 8. The spindle brake is too tight. 9. Worn drive roll. 	<ol style="list-style-type: none"> 6. Verify the proper parts are installed. 7. Adjust the tension arm per the Instruction Manual. Most electrodes feed well at a tension arm setting of "3". 8. Verify the spool of wire moves with minimal effort. 9. Replace the drive rolls if worn or filled with dirt.
Wire feed speed consistently operates at the wrong value. The speed changes when the wire feed speed knob is adjusted.	<ol style="list-style-type: none"> 1. The wrong gear is installed in the wire drive. 2. The brushes on the motor are worn. 	<ol style="list-style-type: none"> 1. Install the proper pinion gear in the wire drive. 2. Replace the motor/gearbox assembly.
The motor runs at max WFS and there is no change when the wire feed speed knob is adjusted.	<ol style="list-style-type: none"> 1. The tachometer is connected improperly. 2. The tachometer has failed. 	<ol style="list-style-type: none"> 1. Verify all of the tachometer leads are properly connected. 2. Replace the motor and tachometer assembly.
Variable or "hunting" arc.	<ol style="list-style-type: none"> 1. Wrong size, worn and/or melted contact tip 2. Worn work cable or poor work connection. 3. Wrong polarity. 4. The gas nozzle is extended beyond the contact tip or the wire stickout is too long. 5. Poor gas shielding on processes requiring gas. 	<ol style="list-style-type: none"> 1. Replace the contact tip. 2. Verify all work and electrode connections are tight and that the cables are in good condition. Clean/replace as necessary. 3. Adjust polarity to the recommended procedure. Verify DIP switch #7 setting matches the electrode polarity. 4. Adjust the gas nozzle and shorten the stickout to ½ to ¾ inches. 5. Check gas flow and mixture. Remove or block sources of drafts.
When the trigger is pulled, the wire feeds slowly.	The Run-In set to "ON"	Use the set-up Push-button to turn Run-in OFF.
Poor arc starts with sticking or "blast-offs", weld porosity, narrow and ropy looking bead.	Improper procedures or techniques.	See "Gas Metal Arc Welding Guide" (GS-100)



If for any reason you do not understand the test procedures or are unable to perform the tests/repairs safely, contact your Lincoln Authorized Service Facility for technical troubleshooting assistance before you proceed.

WWW.LINCOLNELECTRIC.COM/LOCATOR

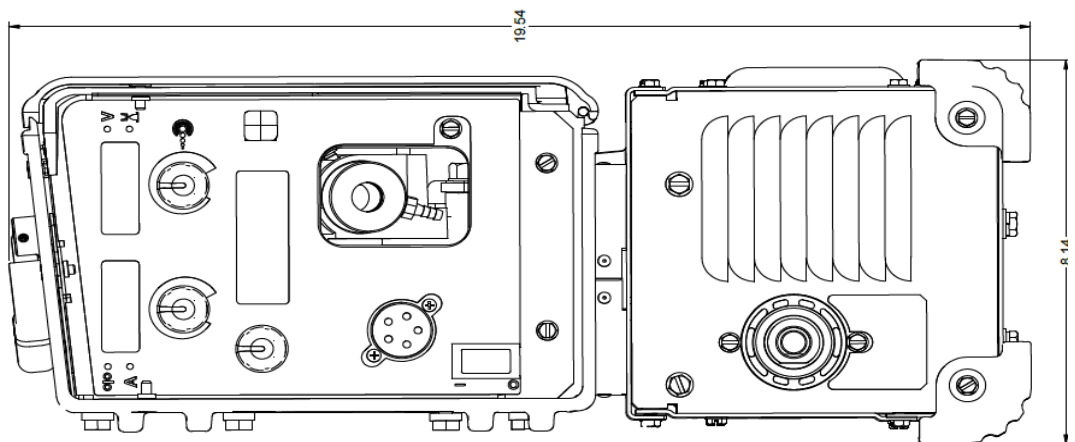
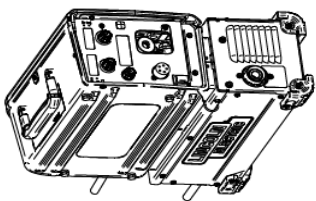
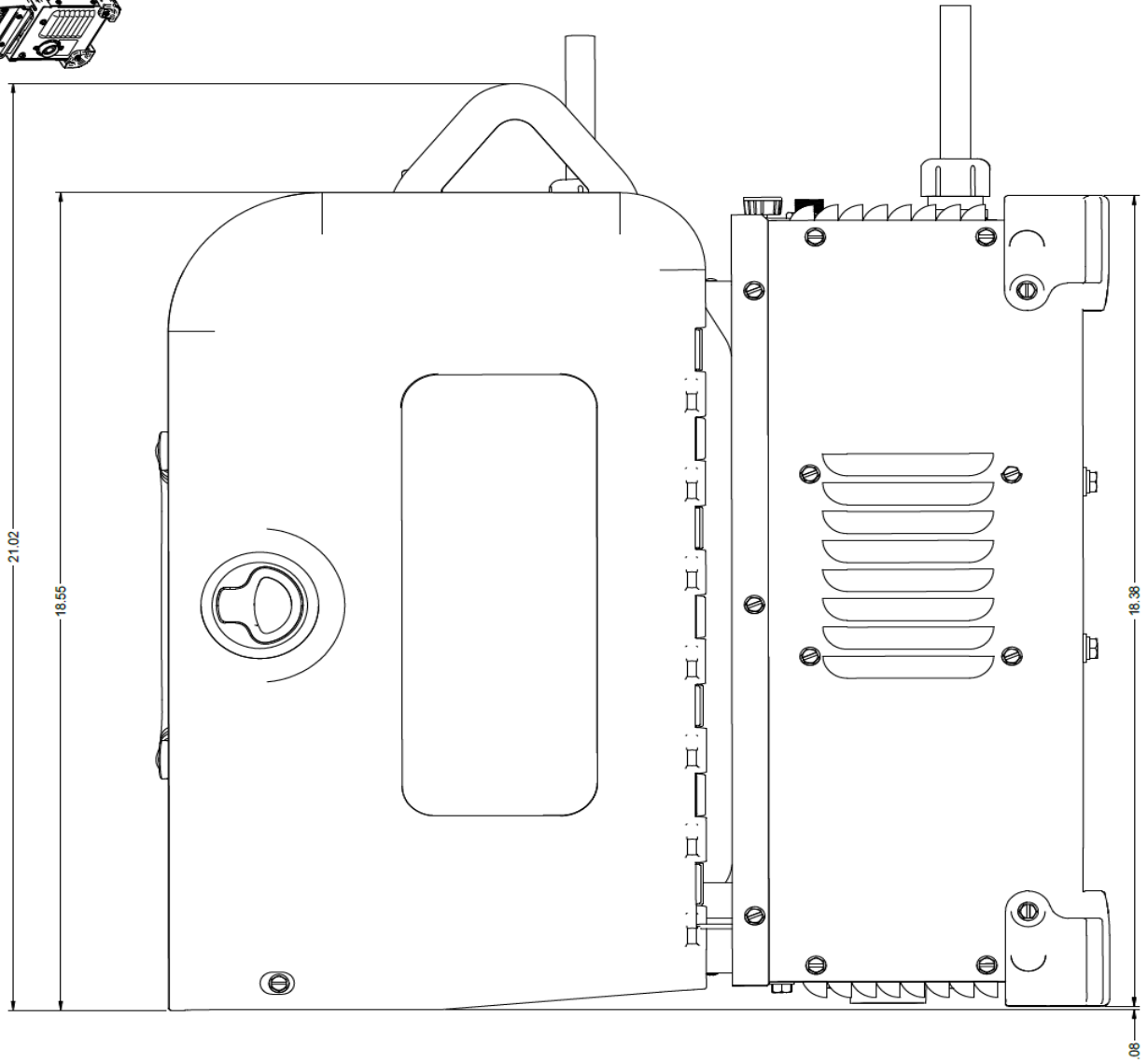
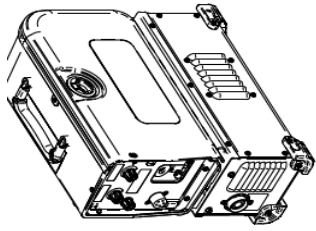

This page intentionally left blank

This page intentionally left blank

This page intentionally left blank

			
WARNING	<ul style="list-style-type: none"> Do not touch electrically live parts or electrode with skin or wet clothing. Insulate yourself from work and ground. 	<ul style="list-style-type: none"> Keep flammable materials away. 	<ul style="list-style-type: none"> Wear eye, ear and body protection.
Spanish AVISO DE PRECAUCION	<ul style="list-style-type: none"> No toque las partes o los electrodos bajo carga con la piel o ropa mojada. Aíslese del trabajo y de la tierra. 	<ul style="list-style-type: none"> Mantenga el material combustible fuera del área de trabajo. 	<ul style="list-style-type: none"> Protéjase los ojos, los oídos y el cuerpo.
French ATTENTION	<ul style="list-style-type: none"> Ne laissez ni la peau ni des vêtements mouillés entrer en contact avec des pièces sous tension. Isolez-vous du travail et de la terre. 	<ul style="list-style-type: none"> Gardez à l'écart de tout matériel inflammable. 	<ul style="list-style-type: none"> Protégez vos yeux, vos oreilles et votre corps.
German WARNUNG	<ul style="list-style-type: none"> Berühren Sie keine stromführenden Teile oder Elektroden mit Ihrem Körper oder feuchter Kleidung! Isolieren Sie sich von den Elektroden und dem Erdboden! 	<ul style="list-style-type: none"> Entfernen Sie brennbares Material! 	<ul style="list-style-type: none"> Tragen Sie Augen-, Ohren- und Körperschutz!
Portuguese ATENÇÃO	<ul style="list-style-type: none"> Não toque partes elétricas e electrodos com a pele ou roupa molhada. Isole-se da peça e terra. 	<ul style="list-style-type: none"> Mantenha inflamáveis bem guardados. 	<ul style="list-style-type: none"> Use proteção para a vista, ouvido e corpo.
Japanese 注意事項	<ul style="list-style-type: none"> 通電中の電気部品、又は溶材にヒフやぬれた布で触れないこと。 施工物やアースから身体が絶縁されている様にして下さい。 	<ul style="list-style-type: none"> 燃えやすいものの側での溶接作業は絶対にしてはなりません。 	<ul style="list-style-type: none"> 目、耳及び身体に保護具をして下さい。
Chinese 警告	<ul style="list-style-type: none"> 皮肤或湿衣物切勿接触带电部件及焊条。 使你自已与地面和工件绝缘。 	<ul style="list-style-type: none"> 把一切易燃物品移离工作场所。 	<ul style="list-style-type: none"> 佩戴眼、耳及身体劳动保护用具。
Korean 위험	<ul style="list-style-type: none"> 전도체나 용접봉을 젖은 형갑 또는 피부로 절대 접촉치 마십시오. 모재와 접지를 접촉치 마십시오. 	<ul style="list-style-type: none"> 인화성 물질을 접근시키지 마십시오. 	<ul style="list-style-type: none"> 눈, 귀와 몸에 보호장구를 착용하십시오.
Arabic تحذير	<ul style="list-style-type: none"> لا تلمس الاجزاء التي يسري فيها التيار الكهربائي أو الألكترود بجسدك أو بالملابس المبللة بالماء. ضع عازلا على جسمك خلال العمل. 	<ul style="list-style-type: none"> ضع المواد القابلة للاشتعال في مكان بعيد. 	<ul style="list-style-type: none"> ضع أدوات وملابس واقية على عينيك وأذنيك وجسمك.

READ AND UNDERSTAND THE MANUFACTURER'S INSTRUCTION FOR THIS EQUIPMENT AND THE CONSUMABLES TO BE USED AND FOLLOW YOUR EMPLOYER'S SAFETY PRACTICES.

SE RECOMIENDA LEER Y ENTENDER LAS INSTRUCCIONES DEL FABRICANTE PARA EL USO DE ESTE EQUIPO Y LOS CONSUMIBLES QUE VA A UTILIZAR, SIGA LAS MEDIDAS DE SEGURIDAD DE SU SUPERVISOR.

LISEZ ET COMPRENEZ LES INSTRUCTIONS DU FABRICANT EN CE QUI REGARDE CET EQUIPMENT ET LES PRODUITS A ETRE EMPLOYES ET SUIVEZ LES PROCEDURES DE SECURITE DE VOTRE EMPLOYEUR.

LESEN SIE UND BEFOLGEN SIE DIE BETRIEBSANLEITUNG DER ANLAGE UND DEN ELEKTRODENEINSATZ DES HERSTELLERS. DIE UNFALLVERHÜTUNGSVORSCHRIFTEN DES ARBEITGEBERS SIND EBENFALLS ZU BEACHTEN.

			
<ul style="list-style-type: none"> ● Keep your head out of fumes. ● Use ventilation or exhaust to remove fumes from breathing zone. 	<ul style="list-style-type: none"> ● Turn power off before servicing. 	<ul style="list-style-type: none"> ● Do not operate with panel open or guards off. 	WARNING
<ul style="list-style-type: none"> ● Los humos fuera de la zona de respiración. ● Mantenga la cabeza fuera de los humos. Utilice ventilación o aspiración para gases. 	<ul style="list-style-type: none"> ● Desconectar el cable de alimentación de poder de la máquina antes de iniciar cualquier servicio. 	<ul style="list-style-type: none"> ● No operar con panel abierto o guardas quitadas. 	Spanish AVISO DE PRECAUCION
<ul style="list-style-type: none"> ● Gardez la tête à l'écart des fumées. ● Utilisez un ventilateur ou un aspirateur pour ôter les fumées des zones de travail. 	<ul style="list-style-type: none"> ● Débranchez le courant avant l'entretien. 	<ul style="list-style-type: none"> ● N'opérez pas avec les panneaux ouverts ou avec les dispositifs de protection enlevés. 	French ATTENTION
<ul style="list-style-type: none"> ● Vermeiden Sie das Einatmen von Schweißrauch! ● Sorgen Sie für gute Be- und Entlüftung des Arbeitsplatzes! 	<ul style="list-style-type: none"> ● Strom vor Wartungsarbeiten abschalten! (Netzstrom völlig öffnen; Maschine anhalten!) 	<ul style="list-style-type: none"> ● Anlage nie ohne Schutzgehäuse oder Innenschutzverkleidung in Betrieb setzen! 	German WARNUNG
<ul style="list-style-type: none"> ● Mantenha seu rosto da fumaça. ● Use ventilação e exaustão para remover fumo da zona respiratória. 	<ul style="list-style-type: none"> ● Não opere com as tampas removidas. ● Desligue a corrente antes de fazer serviço. ● Não toque as partes elétricas nuas. 	<ul style="list-style-type: none"> ● Mantenha-se afastado das partes moventes. ● Não opere com os painéis abertos ou guardas removidas. 	Portuguese ATENÇÃO
<ul style="list-style-type: none"> ● ヒュームから頭を離すようにして下さい。 ● 換気や排煙に十分留意して下さい。 	<ul style="list-style-type: none"> ● メンテナンス・サービスに取りかかる際には、まず電源スイッチを必ず切して下さい。 	<ul style="list-style-type: none"> ● パネルやカバーを取り外したままで機械操作をしないで下さい。 	Japanese 注意事項
<ul style="list-style-type: none"> ● 頭部遠離煙霧。 ● 在呼吸區使用通風或排風器除煙。 	<ul style="list-style-type: none"> ● 維修前切斷電源。 	<ul style="list-style-type: none"> ● 儀表板打開或沒有安全罩時不準作業。 	Chinese 警告
<ul style="list-style-type: none"> ● 얼굴로부터 용접가스를 멀리하십시오. ● 호흡지역으로부터 용접가스를 제거하기 위해 가스제거기나 통풍기를 사용하십시오. 	<ul style="list-style-type: none"> ● 보수전에 전원을 차단하십시오. 	<ul style="list-style-type: none"> ● 판넬이 열린 상태로 작동치 마십시오. 	Korean 위험
<ul style="list-style-type: none"> ● ابعد رأسك بعيداً عن الدخان. ● استعمل التهوية أو جهاز ضغط الدخان للخارج لكي تبعد الدخان عن المنطقة التي تتنفس فيها. 	<ul style="list-style-type: none"> ● اقطع التيار الكهربائي قبل القيام بأية صيانة. 	<ul style="list-style-type: none"> ● لا تشغيل هذا الجهاز اذا كانت الاغطية الحديدية الواقية ليست عليه. 	Arabic تحذير

LEIA E COMPREENDA AS INSTRUÇÕES DO FABRICANTE PARA ESTE EQUIPAMENTO E AS PARTES DE USO, E SIGA AS PRÁTICAS DE SEGURANÇA DO EMPREGADOR.

使う機械や溶材のメーカーの指示書をよく読み、まず理解して下さい。そして貴社の安全規定に従って下さい。

請詳細閱讀並理解製造廠提供的說明以及應該使用的銀焊材料，並請遵守貴方的有關勞動保護規定。

이 제품에 동봉된 작업지침서를 숙지하시고 귀사의 작업자 안전수칙을 준수하시기 바랍니다.

اقرأ بتمعن وافهم تعليمات المصنع المنتج لهذه المعدات والمواد قبل استعمالها واتبع تعليمات الوقاية لصاحب العمل.

CUSTOMER ASSISTANCE POLICY

The business of Lincoln Electric is manufacturing and selling high quality welding equipment, automated welding systems, consumables, and cutting equipment. Our challenge is to meet the needs of our customers, who are experts in their fields, and to exceed their expectations. On occasion, purchasers may ask Lincoln Electric for information or technical information about their use of our products. Our employees respond to inquiries to the best of their ability based on information and specifications provided to them by the customers and the knowledge they may have concerning the application. Our employees, however, are not in a position to verify the information provided or to evaluate the engineering requirements for the particular weldment, or to provide engineering advice in relation to a specific situation or application. Accordingly, Lincoln Electric does not warrant or guarantee or assume any liability with respect to such information or communications. Moreover, the provision of such information or technical information does not create, expand, or alter any warranty on our products. Any express or implied warranty that might arise from the information or technical information, including any implied warranty of merchantability or any warranty of fitness for any customers' particular purpose or any other equivalent or similar warranty is specifically disclaimed.

Lincoln Electric is a responsive manufacturer, but the definition of specifications, and the selection and use of specific products sold by Lincoln Electric is solely within the control of, and remains the sole responsibility of the customer. Many variables beyond the control of Lincoln Electric affect the results obtained in applying these types of fabrication methods and service requirements.

WELD FUME CONTROL EQUIPMENT

The operation of welding fume control equipment is affected by various factors including proper use and positioning of the equipment, maintenance of the equipment and the specific welding procedure and application involved. Worker exposure level should be checked upon installation and periodically thereafter to be certain it is within applicable OSHA PEL and ACGIH TLV limits.



THE LINCOLN ELECTRIC COMPANY

22801 St. Clair Avenue • Cleveland, OH • 44117-1199 • U.S.A.
Phone: +1.216.481.8100 • www.lincolnelectric.com