

WELDING POSITIONERS

Mechanized Automation



AD2403-1;
AD2403-2



AD2403-4;
AD2403-5;
AD2403-6



AD2403-7;
AD2403-8

Lincoln Electric® positioners can be combined with manipulators or robots to produce a work cell for high quality and efficiency. Positioners feature a heavy duty integrated tilt gear to ensure smooth turning and tilting.

Standard features include:

- AC brake motors
- Solid state controls with dynamic braking on the rotation drives
- Worm gear reducers
- Universal plugs for easy installation and change out of foot switches, hand pendants and tachometers
- High frequency protection

Load Capacity lb (kg) »

350 (159)
4500 (2041)

Input »



Product Number »

See back for complete specs

STANDARD SPECIFICATIONS

Product Name	Product Number	Load Capacity lb (kg)	Input Power Voltage/Phase/Hertz	Swing Radius in (mm)	Weight lb (kg)
Table Top Positioner	AD2403-1	350 (159) Vertical and Horizontal	115/1/60	10 (254)	115 (52)
Table Top Positioner – Slow Speed	AD2403-2			20-33 (508-838) @ 90° tilt	
Floor Positioner 1500 lb (680.3 kg)	AD2403-3	1500 (680) 4 in (102 mm) overhung from face to table, 4 in (102 mm) eccentricity	230/3/60	28-47 (711-1194) @ 90° tilt	1750 (794)
Floor Positioner 3000 lb (1361 kg)	AD2403-4	3000 (1361) 6 in (152 mm) overhung from face to table, 6 in (152 mm) eccentricity	460/3/60		
Floor Positioner 3000 lb (1361 kg)	AD2403-5		600/3/60		
Floor Positioner 3000 lb (1361 kg)	AD2403-6	4500 (2041) 12 in (305 mm) overhung from face to table, 12 in (305 mm) eccentricity	460/3/60	34.6-51.1 (879-1298) @ 90° tilt	3000 (1361)
Floor Positioner 4500 lb (2041 kg)	AD2403-7		600/3/60		
Floor Positioner 4500 lb (2041 kg)	AD2403-8				

ROTATION SPECIFICATIONS

Product Name	Product Number	Rotational Motor Size (HP)	Rotation Speed rpm	Rotation Torque in-lb (Nm)
Table Top Positioner	AD2403-1	1/8 HP Gearmotor	0.65-13	175 (19.7)
Table Top Positioner – Slow Speed	AD2403-2	1/5 HP Gearmotor	0.22-4.4	
Floor Positioner 1500 lb (680.3 kg)	AD2403-3	1/2 HP DC Motor	0.08-1.6 Variable	6000 (6779)
Floor Positioner 3000 lb (1361 kg)	AD2403-4	1 HP Motor	0.046-1.4 Variable	18000 (2033.7)
Floor Positioner 3000 lb (1361 kg)	AD2403-5			
Floor Positioner 3000 lb (1361 kg)	AD2403-6			
Floor Positioner 4500 lb (2041 kg)	AD2403-7	1.5 HP Motor	0.03-0.97 Variable	54000 (6101.1)
Floor Positioner 4500 lb (2041 kg)	AD2403-8			

TILT SPECIFICATIONS

Product Name	Product Number	Tilt Motor Size	Tilt Speed Degrees in/seconds	Tilt Torque in-lb (Nm)	Tilt Range Degrees	Spindle Thru Hole in (mm)
Table Top Positioner	AD2403-1	N/A	N/A	N/A	0-90, pinned @ 15° increments	2.5 (64)
Table Top Positioner – Slow Speed	AD2403-2					
Floor Positioner 1500 lb (680.3 kg)	AD2403-3	1/2 HP AC Brakemotor	135/22	12000 (1355.8) inherent	0-135 Motorized	0.75 (19)
Floor Positioner 3000 lb (1361 kg)	AD2403-4	3/4 HP AC Brakemotor	135/36	35256 (3983.3) inherent		1.5 (38)
Floor Positioner 3000 lb (1361 kg)	AD2403-5					
Floor Positioner 3000 lb (1361 kg)	AD2403-6	1.5 HP AC Brakemotor	135/30	79872 (9024.3) inherent		2.25 (57)
Floor Positioner 4500 lb (2041 kg)	AD2403-7					
Floor Positioner 4500 lb (2041 kg)	AD2403-8					

Top Views

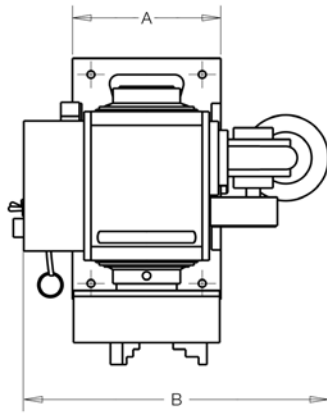

AD2403-1,
AD2403-2

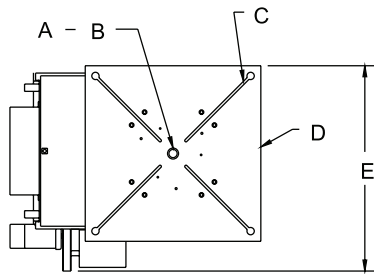

AD2403-3,
AD2403-4,
AD2403-5,
AD2403-6,
AD2403-7,
AD2403-8

Side Views

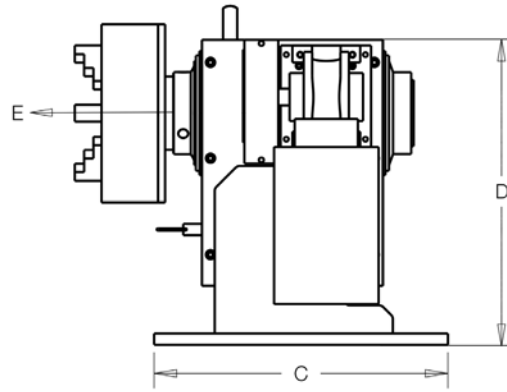

AD2403-1,
AD2403-2

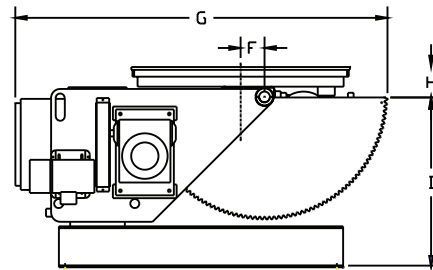

AD2403-3,
AD2403-4,
AD2403-5,
AD2403-6,
AD2403-7,
AD2403-8

QUICKSET SPECIFICATIONS

Product Name	Product Number	A Chuck Diameter in (mm)	B Width in (mm)	C Length in (mm)	D Table Height (min) in (mm)	E Thru Hole in (mm)
Table Top Positioner	AD2403-1	8.25 [210]	16.4 [418]	13 [330]	15 [381]	2.5 [63.5]
Table Top Positioner – Slow Speed	AD2403-2	8 [203]				

Product Name	Product Number	A Pilot Hole Ø x ↓ in (mm)	B Thru Hole in (mm)	C "T" Slot Quantity	C ANSI Std "T" Nut Size in (mm)	D Table Size in (mm)	E Width in (mm)
Floor Positioner 1500 lb [680.3]	AD2403-3	2 x 1 [51 x 25]	3/4 [19]	4	1/2 [13]	24 [610] square table	30.25 [768]
Floor Positioner 3000 lb [1361]	AD2403-4	2.75 x 0.25 [70 x 6]	1/5 [38]		5/8 [16]	60 [762] square table	39.25 [997]
Floor Positioner 3000 lb [1361]	AD2403-5						
Floor Positioner 3000 lb [1361]	AD2403-6						
Floor Positioner 4500 lb [2041]	AD2403-7	3 x 0.25 [76 x 6]	2.25 [57]		48 [1219] square table	54.187 [1376]	
Floor Positioner 4500 lb [2041]	AD2403-8						
Product Name	Product Number	F Rotation Offset in (mm)	G Length in (mm)	H Inherent Overhang in (mm)	I Tilt Axis Height in (mm)	Table Height (min) in (mm)	Positions (max) in (mm)
Floor Positioner 1500 lb [680.3]	AD2403-3	3 [76]	45.75 [1162]	4 [102]	19.5 [495]	23.5 [597]	375 [946]
Floor Positioner 3000 lb [1361]	AD2403-4	4 [102]	58.25 [1479]	5.75 [146]	27.25 [692]	33 [838]	53 [1346]
Floor Positioner 3000 lb [1361]	AD2403-5						
Floor Positioner 3000 lb [1361]	AD2403-6						
Floor Positioner 4500 lb [2041]	AD2403-7	5 [127]	67.687 [1719]	33.25 [845]	39 [991]	57 [1448]	
Floor Positioner 4500 lb [2041]	AD2403-8						

ACCESSORIES

Product Name	Product Number	Table Top Positioner (AD2403-1)	Table Top Positioner – Slow Speed (AD2403-2)	Floor Positioner 1500 lb (680.3 kg) (AD2403-3)	Floor Positioner 3000 lb (1361 kg) (AD2403-4)	Floor Positioner 3000 lb (1361 kg) (AD2403-5)	Floor Positioner 3000 lb (1361 kg) (AD2403-6)	Floor Positioner 4500 lb (2041 kg) (AD2403-7)	Floor Positioner 4500 lb (2041 kg) (AD2403-8)
Jaw Chucks in (mm)									
Jaw Chuck 20 (508)	AD2405-1			.					
Jaw Chuck 31 (787.4)	AD2405-2				.	.	.		
Jaw Chuck 44 (1117.6)	AD2405-3				.	.	.		
Jaw Chuck 68 (1727.2)	AD2405-4				.	.	.		
Jaw Chuck 52 (1320.8)	AD2405-5							.	.
Optional Jaw Chuck	AD2405-6
Pipe Support Stands lb (kg)									
Pipe Support Stand 1500 (680)	AD2406-2			.					
Pipe Support Stand 3000 (1361)	AD2406-1				.	.	.	(qty 2)	(qty 2)
Additional Accessories									
Spring Loaded Copper Grounding Shoe 600 AMPS PT	AD2404-1
Footswitch Forward/Stop/Reverse	AD2404-2
Footswitch Variable Speed Control (Slow/Fast)	AD2404-3
Positioner Linear Weld Speed Controller	AD2404-4
Digital Tachometer	AD2404-5
Control Cable 25 ft (7.6 m)	AD2404-6

CUSTOMER ASSISTANCE POLICY

The business of The Lincoln Electric Company is manufacturing and selling high quality welding equipment, consumables, and cutting equipment. Our challenge is to meet the needs of our customers and to exceed their expectations. On occasion, purchasers may ask Lincoln Electric for information or advice about their use of our products. Our employees respond to inquiries to the best of their ability based on information provided to them by the customers and the knowledge they may have concerning the application. Our employees, however, are not in a position to verify the information provided or to evaluate the engineering requirements for the particular weldment. Accordingly, Lincoln Electric does not warrant or guarantee or assume any liability with respect to such information or advice. Moreover, the provision of such information or advice does not create, expand, or alter any warranty on our products. Any express or implied warranty that might arise from the information or advice, including any implied warranty of merchantability or any warranty of fitness for any customers' particular purpose is specifically disclaimed.

Lincoln Electric is a responsive manufacturer, but the selection and use of specific products sold by Lincoln Electric is solely within the control of, and remains the sole responsibility of the customer. Many variables beyond the control of Lincoln Electric affect the results obtained in applying these types of fabrication methods and service requirements.

Subject to Change – This information is accurate to the best of our knowledge at the time of printing. Please refer to www.lincolnelectric.com for any updated information.

THE ONLY SINGLE-SOURCE AUTOMATION PROVIDER

Lincoln Electric has built a solutions portfolio to include all of the competencies to support your need to improve productivity, quality and safety. Lincoln Electric can modify or completely customize the creation of your weld cell to meet those precise needs.

With a global network of facilities and people, you'll get quick response and personalized attention. Contact one of the below facilities for more information on the types of solutions available to help you produce faster, more repeatable, higher quality results.

UNITED STATES

22221 Saint Clair Ave.
Cleveland, Ohio · 44117-2552
Phone: +1.888.935.3878

CANADA

939 Gana Court
Mississauga, Ontario · L5S 1N9
Phone: +1.905.565.5600

MEXICO

Calzada Azcapotzalco-La Villa 869
Industrial Vallejo, Mexico DF · CP 02330
Phone: +52.55.5063.0330

www.lincolnelectric.com/automated-solutions