



NOTE: This manual will cover most of the troubleshooting and repair procedures for the code numbers listed. Some variances may exist when troubleshooting/repairing later code numbers.

INVERTEC V300-PRO

For use with machines having Code Numbers:

**9555, 9825, 9934, 9965,
10034, 10035, 10130,
10131, 10256, 10257,**

SERVICE MANUAL

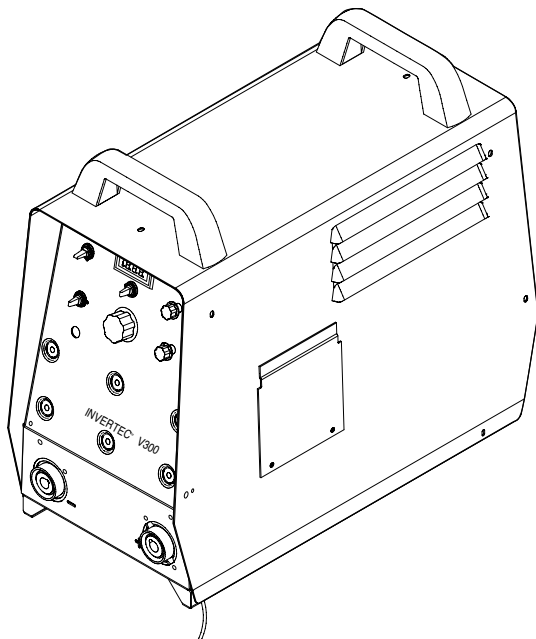

⚠ WARNING

⚠ CALIFORNIA PROPOSITION 65 WARNINGS ⚠

Diesel engine exhaust and some of its constituents are known to the State of California to cause cancer, birth defects, and other reproductive harm.

The Above For Diesel Engines

The engine exhaust from this product contains chemicals known to the State of California to cause cancer, birth defects, or other reproductive harm.

The Above For Gasoline Engines

ARC WELDING CAN BE HAZARDOUS. PROTECT YOURSELF AND OTHERS FROM POSSIBLE SERIOUS INJURY OR DEATH. KEEP CHILDREN AWAY. PACEMAKER WEARERS SHOULD CONSULT WITH THEIR DOCTOR BEFORE OPERATING.

Read and understand the following safety highlights. For additional safety information, it is strongly recommended that you purchase a copy of "Safety in Welding & Cutting - ANSI Standard Z49.1" from the American Welding Society, P.O. Box 351040, Miami, Florida 33135 or CSA Standard W117.2-1974. A Free copy of "Arc Welding Safety" booklet E205 is available from the Lincoln Electric Company, 22801 St. Clair Avenue, Cleveland, Ohio 44117-1199.

BE SURE THAT ALL INSTALLATION, OPERATION, MAINTENANCE AND REPAIR PROCEDURES ARE PERFORMED ONLY BY QUALIFIED INDIVIDUALS.



FOR ENGINE powered equipment.

1.a. Turn the engine off before troubleshooting and maintenance work unless the maintenance work requires it to be running.



1.b. Operate engines in open, well-ventilated areas or vent the engine exhaust fumes outdoors.



1.c. Do not add the fuel near an open flame welding arc or when the engine is running. Stop the engine and allow it to cool before refueling to prevent spilled fuel from vaporizing on contact with hot engine parts and igniting. Do not spill fuel when filling tank. If fuel is spilled, wipe it up and do not start engine until fumes have been eliminated.

1.d. Keep all equipment safety guards, covers and devices in position and in good repair. Keep hands, hair, clothing and tools away from V-belts, gears, fans and all other moving parts when starting, operating or repairing equipment.

1.e. In some cases it may be necessary to remove safety guards to perform required maintenance. Remove guards only when necessary and replace them when the maintenance requiring their removal is complete. Always use the greatest care when working near moving parts.



1.f. Do not put your hands near the engine fan. Do not attempt to override the governor or idler by pushing on the throttle control rods while the engine is running.

1.g. To prevent accidentally starting gasoline engines while turning the engine or welding generator during maintenance work, disconnect the spark plug wires, distributor cap or magneto wire as appropriate.



1.h. To avoid scalding, do not remove the radiator pressure cap when the engine is hot.

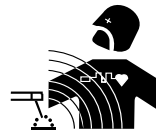

ELECTRIC AND MAGNETIC FIELDS may be dangerous

2.a. Electric current flowing through any conductor causes localized Electric and Magnetic Fields (EMF). Welding current creates EMF fields around welding cables and welding machines

2.b. EMF fields may interfere with some pacemakers, and welders having a pacemaker should consult their physician before welding.

2.c. Exposure to EMF fields in welding may have other health effects which are now not known.

2.d. All welders should use the following procedures in order to minimize exposure to EMF fields from the welding circuit:

2.d.1. Route the electrode and work cables together - Secure them with tape when possible.

2.d.2. Never coil the electrode lead around your body.

2.d.3. Do not place your body between the electrode and work cables. If the electrode cable is on your right side, the work cable should also be on your right side.

2.d.4. Connect the work cable to the workpiece as close as possible to the area being welded.

2.d.5. Do not work next to welding power source.

Mar '95



ELECTRIC SHOCK can kill.

- 3.a. The electrode and work (or ground) circuits are electrically “hot” when the welder is on. Do not touch these “hot” parts with your bare skin or wet clothing. Wear dry, hole-free gloves to insulate hands.
- 3.b. Insulate yourself from work and ground using dry insulation. Make certain the insulation is large enough to cover your full area of physical contact with work and ground.
- In addition to the normal safety precautions, if welding must be performed under electrically hazardous conditions (in damp locations or while wearing wet clothing; on metal structures such as floors, gratings or scaffolds; when in cramped positions such as sitting, kneeling or lying, if there is a high risk of unavoidable or accidental contact with the workpiece or ground) use the following equipment:**
- Semiautomatic DC Constant Voltage (Wire) Welder.
 - DC Manual (Stick) Welder.
 - AC Welder with Reduced Voltage Control.
- 3.c. In semiautomatic or automatic wire welding, the electrode, electrode reel, welding head, nozzle or semiautomatic welding gun are also electrically “hot”.
- 3.d. Always be sure the work cable makes a good electrical connection with the metal being welded. The connection should be as close as possible to the area being welded.
- 3.e. Ground the work or metal to be welded to a good electrical (earth) ground.
- 3.f. Maintain the electrode holder, work clamp, welding cable and welding machine in good, safe operating condition. Replace damaged insulation.
- 3.g. Never dip the electrode in water for cooling.
- 3.h. Never simultaneously touch electrically “hot” parts of electrode holders connected to two welders because voltage between the two can be the total of the open circuit voltage of both welders.
- 3.i. When working above floor level, use a safety belt to protect yourself from a fall should you get a shock.
- 3.j. Also see Items 6.c. and 8.



ARC RAYS can burn.

- 4.a. Use a shield with the proper filter and cover plates to protect your eyes from sparks and the rays of the arc when welding or observing open arc welding. Headshield and filter lens should conform to ANSI Z87.1 standards.
- 4.b. Use suitable clothing made from durable flame-resistant material to protect your skin and that of your helpers from the arc rays.
- 4.c. Protect other nearby personnel with suitable, non-flammable screening and/or warn them not to watch the arc nor expose themselves to the arc rays or to hot spatter or metal.



FUMES AND GASES can be dangerous.

- 5.a. Welding may produce fumes and gases hazardous to health. Avoid breathing these fumes and gases. When welding, keep your head out of the fume. Use enough ventilation and/or exhaust at the arc to keep fumes and gases away from the breathing zone. **When welding with electrodes which require special ventilation such as stainless or hard facing (see instructions on container or MSDS) or on lead or cadmium plated steel and other metals or coatings which produce highly toxic fumes, keep exposure as low as possible and below Threshold Limit Values (TLV) using local exhaust or mechanical ventilation. In confined spaces or in some circumstances, outdoors, a respirator may be required. Additional precautions are also required when welding on galvanized steel.**
5. b. The operation of welding fume control equipment is affected by various factors including proper use and positioning of the equipment, maintenance of the equipment and the specific welding procedure and application involved. Worker exposure level should be checked upon installation and periodically thereafter to be certain it is within applicable OSHA PEL and ACGIH TLV limits.
- 5.c. Do not weld in locations near chlorinated hydrocarbon vapors coming from degreasing, cleaning or spraying operations. The heat and rays of the arc can react with solvent vapors to form phosgene, a highly toxic gas, and other irritating products.
- 5.d. Shielding gases used for arc welding can displace air and cause injury or death. Always use enough ventilation, especially in confined areas, to insure breathing air is safe.
- 5.e. Read and understand the manufacturer's instructions for this equipment and the consumables to be used, including the material safety data sheet (MSDS) and follow your employer's safety practices. MSDS forms are available from your welding distributor or from the manufacturer.
- 5.f. Also see item 1.b.

AUG 06

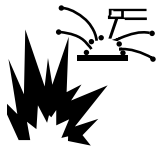

WELDING SPARKS can cause fire or explosion.

6.a. Remove fire hazards from the welding area.

If this is not possible, cover them to prevent the welding sparks from starting a fire.

Remember that welding sparks and hot

materials from welding can easily go through small cracks and openings to adjacent areas. Avoid welding near hydraulic lines. Have a fire extinguisher readily available.

6.b. Where compressed gases are to be used at the job site, special precautions should be used to prevent hazardous situations. Refer to "Safety in Welding and Cutting" (ANSI Standard Z49.1) and the operating information for the equipment being used.

6.c. When not welding, make certain no part of the electrode circuit is touching the work or ground. Accidental contact can cause overheating and create a fire hazard.

6.d. Do not heat, cut or weld tanks, drums or containers until the proper steps have been taken to insure that such procedures will not cause flammable or toxic vapors from substances inside. They can cause an explosion even though they have been "cleaned". For information, purchase "Recommended Safe Practices for the Preparation for Welding and Cutting of Containers and Piping That Have Held Hazardous Substances", AWS F4.1 from the American Welding Society (see address above).

6.e. Vent hollow castings or containers before heating, cutting or welding. They may explode.

6.f. Sparks and spatter are thrown from the welding arc. Wear oil free protective garments such as leather gloves, heavy shirt, cuffless trousers, high shoes and a cap over your hair. Wear ear plugs when welding out of position or in confined places. Always wear safety glasses with side shields when in a welding area.

6.g. Connect the work cable to the work as close to the welding area as practical. Work cables connected to the building framework or other locations away from the welding area increase the possibility of the welding current passing through lifting chains, crane cables or other alternate circuits. This can create fire hazards or overheat lifting chains or cables until they fail.

6.h. Also see item 1.c.

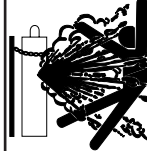

CYLINDER may explode if damaged.

7.a. Use only compressed gas cylinders containing the correct shielding gas for the process used and properly operating regulators designed for the gas and pressure used. All hoses, fittings, etc. should be suitable for the application and maintained in good condition.

7.b. Always keep cylinders in an upright position securely chained to an undercarriage or fixed support.

7.c. Cylinders should be located:

- Away from areas where they may be struck or subjected to physical damage.

- A safe distance from arc welding or cutting operations and any other source of heat, sparks, or flame.

7.d. Never allow the electrode, electrode holder or any other electrically "hot" parts to touch a cylinder.

7.e. Keep your head and face away from the cylinder valve outlet when opening the cylinder valve.

7.f. Valve protection caps should always be in place and hand tight except when the cylinder is in use or connected for use.

7.g. Read and follow the instructions on compressed gas cylinders, associated equipment, and CGA publication P-1, "Precautions for Safe Handling of Compressed Gases in Cylinders," available from the Compressed Gas Association 1235 Jefferson Davis Highway, Arlington, VA 22202.



FOR ELECTRICALLY powered equipment.

8.a. Turn off input power using the disconnect switch at the fuse box before working on the equipment.

8.b. Install equipment in accordance with the U.S. National Electrical Code, all local codes and the manufacturer's recommendations.

8.c. Ground the equipment in accordance with the U.S. National Electrical Code and the manufacturer's recommendations.

Mar '95

PRÉCAUTIONS DE SÛRETÉ

Pour votre propre protection lire et observer toutes les instructions et les précautions de sûreté spécifiques qui paraissent dans ce manuel aussi bien que les précautions de sûreté générales suivantes:

Sûreté Pour Soudage A L'Arc

1. Protégez-vous contre la secousse électrique:
 - a. Les circuits à l'électrode et à la pièce sont sous tension quand la machine à souder est en marche. Eviter toujours tout contact entre les parties sous tension et la peau nue ou les vêtements mouillés. Porter des gants secs et sans trous pour isoler les mains.
 - b. Faire très attention de bien s'isoler de la masse quand on soude dans des endroits humides, ou sur un plancher métallique ou des grilles métalliques, principalement dans les positions assis ou couché pour lesquelles une grande partie du corps peut être en contact avec la masse.
 - c. Maintenir le porte-électrode, la pince de masse, le câble de soudage et la machine à souder en bon et sûr état de fonctionnement.
 - d. Ne jamais plonger le porte-électrode dans l'eau pour le refroidir.
 - e. Ne jamais toucher simultanément les parties sous tension des porte-électrodes connectés à deux machines à souder parce que la tension entre les deux pinces peut être le total de la tension à vide des deux machines.
 - f. Si on utilise la machine à souder comme une source de courant pour soudage semi-automatique, ces précautions pour le porte-électrode s'appliquent aussi au pistolet de soudage.
2. Dans le cas de travail au dessus du niveau du sol, se protéger contre les chutes dans le cas où on recoit un choc. Ne jamais enrouler le câble-électrode autour de n'importe quelle partie du corps.
3. Un coup d'arc peut être plus sévère qu'un coup de soliel, donc:
 - a. Utiliser un bon masque avec un verre filtrant approprié ainsi qu'un verre blanc afin de se protéger les yeux du rayonnement de l'arc et des projections quand on soude ou quand on regarde l'arc.
 - b. Porter des vêtements convenables afin de protéger la peau de soudeur et des aides contre le rayonnement de l'arc.
 - c. Protéger l'autre personnel travaillant à proximité au soudage à l'aide d'écrans appropriés et non-inflammables.
4. Des gouttes de laitier en fusion sont émises de l'arc de soudage. Se protéger avec des vêtements de protection libres de l'huile, tels que les gants en cuir, chemise épaisse, pantalons sans revers, et chaussures montantes.
5. Toujours porter des lunettes de sécurité dans la zone de soudage. Utiliser des lunettes avec écrans latéraux dans les

zones où l'on pique le laitier.

6. Eloigner les matériaux inflammables ou les recouvrir afin de prévenir tout risque d'incendie dû aux étincelles.
7. Quand on ne soude pas, poser la pince à un endroit isolé de la masse. Un court-circuit accidentel peut provoquer un échauffement et un risque d'incendie.
8. S'assurer que la masse est connectée le plus près possible de la zone de travail qu'il est pratique de le faire. Si on place la masse sur la charpente de la construction ou d'autres endroits éloignés de la zone de travail, on augmente le risque de voir passer le courant de soudage par les chaînes de levage, câbles de grue, ou autres circuits. Cela peut provoquer des risques d'incendie ou d'échauffement des chaînes et des câbles jusqu'à ce qu'ils se rompent.
9. Assurer une ventilation suffisante dans la zone de soudage. Ceci est particulièrement important pour le soudage de tôles galvanisées plombées, ou cadmiées ou tout autre métal qui produit des fumées toxiques.
10. Ne pas souder en présence de vapeurs de chlore provenant d'opérations de dégraissage, nettoyage ou pistologie. La chaleur ou les rayons de l'arc peuvent réagir avec les vapeurs du solvant pour produire du phosgène (gas fortement toxique) ou autres produits irritants.
11. Pour obtenir de plus amples renseignements sur la sûreté, voir le code "Code for safety in welding and cutting" CSA Standard W 117.2-1974.

PRÉCAUTIONS DE SÛRETÉ POUR LES MACHINES À SOUDER À TRANSFORMATEUR ET À REDRESSEUR

1. Relier à la terre le châssis du poste conformément au code de l'électricité et aux recommandations du fabricant. Le dispositif de montage ou la pièce à souder doit être branché à une bonne mise à la terre.
2. Autant que possible, l'installation et l'entretien du poste seront effectués par un électricien qualifié.
3. Avant de faire des travaux à l'intérieur de poste, la débrancher à l'interrupteur à la boîte de fusibles.
4. Garder tous les couvercles et dispositifs de sûreté à leur place.

MASTER TABLE OF CONTENTS FOR ALL SECTIONS

Safety	i-iv
Installation	Section A
Operation	Section B
Accessories	Section C
Maintenance	Section D
Theory of Operation	Section E
Troubleshooting and Repair	Section F
Electrical Diagrams	Section G
Parts ManualP243 Series

TABLE OF CONTENTS - INSTALLATION SECTION -

InstallationSection A

Technical SpecificationsA-2
 LocationA-3
 Electrical Installation.....A-3
 Input Connections.....A-4
 Wire feeder and Accessory Connections.....A-4, A-5
 Output Connection.....A-6

Return to Master TOC

Return to Master TOC

Return to Master TOC

Return to Master TOC

V300-PRO



TECHNICAL SPECIFICATIONS - V300-PRO (K1349-3, K1349-4)

INPUT									
THREE PHASE					SINGLE PHASE				
<u>Standard Voltage</u>		<u>Input Current at Rated Output</u>		<u>Code Number</u>	<u>Standard Voltage</u>		<u>Input Current at Rated Output</u>		<u>Code Number</u>
208/230/460/575 50/60		48/43/24/20		9825,9834,9965 10034,10035 10130,10131	208/230/460 50/60		69/62/38-		9825,9936,9965 10034, 10130,
RATED OUTPUT									
THREE PHASE					SINGLE PHASE				
<u>Duty Cycle</u>		<u>Amps</u>		<u>Volts at Rated Amperes</u>	<u>Duty Cycle</u>		<u>Amps</u>		<u>Volts at Rated Amperes</u>
60% Duty Cycle		300		32	60% Duty Cycle		200		28
100% Duty Cycle		250		30	100% Duty Cycle		165		26.5
OUTPUT									
THREE PHASE					SINGLE PHASE				
<u>Welding Current Range</u>		<u>Constant Open Circuit Voltage</u>		<u>Auxiliary Power</u>	<u>Welding Current Range</u>		<u>Constant Open Circuit Voltage</u>		<u>Auxiliary Power</u>
5-300 Amps		60-70 VDC		42 VAC, 5.5 Amps 24 VAC, 1 Amp *115 VAC, 2 Amps *Not on all codes	5-200 Amps		60-70 VDC		42 VAC, 5.5 Amps 24 VAC, 1 Amp *115 VAC, 2 Amps *Not on all codes
RECOMMENDED INPUT WIRE AND FUSE SIZES									
THREE PHASE					SINGLE PHASE				
<u>Input Voltage Frequency⁽¹⁾</u>	<u>Fuse (Superlag) or Breaker Size</u>	<u>Input Ampere Rating on Nameplate</u>	<u>Type 75°C Copper Wire in Conduit AWG (IEC) Sizes</u>	<u>Type 75°C Copper Ground Wire in Conduit AWG (IEC) Sizes</u>	<u>Input Voltage Frequency⁽¹⁾</u>	<u>Fuse (Superlag) or Breaker Size</u>	<u>Input Ampere Rating on Nameplate</u>	<u>Type 75°C Copper Wire in Conduit AWG (IEC) Sizes</u>	<u>Type 75°C Copper Ground Wire in Conduit AWG (IEC) Sizes</u>
208/60	60	48	6 (16mm ²)	10 (6mm ²)	208/60	85	69	6 (16mm ²)	10 (6mm ²)
230/60	60	39	8 (10mm ²)	10 (6mm ²)	230/60	80	62	6 (16mm ²)	10 (6mm ²)
460/60	40	25	10 (6mm ²)	10 (6mm ²)	460/60	50	38	8 (10mm ²)	10 (6mm ²)
575/60	30	25	10 (6mm ²)	10 (6mm ²)					
PHYSICAL DIMENSIONS									
<u>Height</u>			<u>Width</u>			<u>Depth</u>		<u>Weight</u>	
18.7 in.			10.8 in.			22.2 in.		64 lbs.	
475 mm			274 mm			564 mm		29 Kg	

V300-PRO



Return to Section TOC

Return to Section TOC

Return to Section TOC

Return to Section TOC

Return to Master TOC

Return to Master TOC

Return to Master TOC

Return to Master TOC

PRODUCT DESCRIPTION

The Invertec V300-PRO is a 300 amp arc welding power source that utilizes single or three phase input power to produce either constant voltage or constant current outputs. The V300-PRO is designed for 50/60 Hz supply systems. The welding response of the Invertec has been optimized for GMAW, SMAW, TIG and FCAW processes. It is designed to be used with the LN-25 and LN-7 semiautomatic wire feeders.

⚠ WARNING



ELECTRIC SHOCK can kill.

- Have an electrician install and service this equipment.
- Turn the input power off at the fuse box before working on equipment.
- Do not touch electrically hot parts.

LOCATION

The Invertec has been designed with many features to protect it from harsh environments. Even so, it is important that simple preventative measures are followed in order to assure long life and reliable operation.

- The machine must be located where there is free circulation of clean air such that air movement into the sides and out the bottom and front will not be restricted. Dirt and dust that can be drawn into the machine should be kept to a minimum. Failure to observe these precautions can result in excessive operating temperatures and nuisance shutdown of the Invertec.
- Keep machine dry. Shelter from rain and snow. Do not place on wet ground or in puddles.

⚠ CAUTION

DO NOT ATTEMPT TO POWER THIS UNIT FROM THE AUXILIARY POWER SUPPLY OF AN ENGINE WELDER.

- Special protection circuits may operate, causing loss of output.
- The supply from engine welders often has excessive voltage peaks because the voltage waveform is usually triangular shaped instead of sinusoidal.
- If voltage peaks from the engine welder are too high (380v on 230v setting), the input circuits of this machine protecting the filter capacitors, FETS and other components from damage will not be energized.

ELECTRICAL INSTALLATION

1. The Invertec should be connected only by a qualified electrician. Installation should be made in accordance with the U.S. National Electrical Code, all local codes and the information detailed below.
2. When received from the factory, multiple voltage (208/230/460) machines are internally connected for 460 volt input.
3. Single voltage, 575 VAC machines, can only be connected to 575 VAC. No internal reconnection for other input voltages is possible.
4. Initial 208 VAC and 230 VAC operation will require a voltage panel setup, as will later reconnection back to 460 VAC:
 - a. Open the access panel on the right side of the machine.
 - b. For 208 or 230: Position the large switch to 200-230.
For 460: Position the large switch to 380-460.
 - c. Move the "A" lead to the appropriate terminal.

CAUTION: DO NOT CHANGE SWITCH POSITION WITH INPUT POWER APPLIED. MAJOR DAMAGE WILL RESULT.

INPUT VOLTAGE SETUP

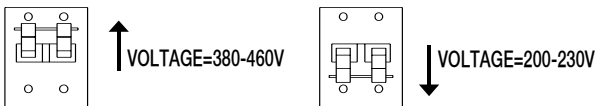
RECONNECT PROCEDURE	⚠ WARNING
1. BE SURE POWER SWITCH IS OFF. 2. CONNECT LEAD 'A' TO DESIRED INPUT VOLTAGE RANGE. 440-460V Ⓣ 380-415V Ⓣ 220-230V Ⓣ 200-208V Ⓣ	 <ul style="list-style-type: none"> • Disconnect input power before inspecting or servicing machine. • Do not operate with wraparound removed. • Do not touch electrically live parts. • Only qualified persons should install, use or service this equipment. <p>ELECTRIC SHOCK CAN KILL.</p> <p>IF MACHINE CEASES TO OPERATE (NO METER, NO FAN) AND THERE IS NO OTHER KNOWN FAILURE: CHECK FUSE; REPLACE WITH A 3 AMP SLOW BLOW ONLY.</p>
3. POSITION SWITCH TO DESIRED INPUT VOLTAGE RANGE. 	
THE LINCOLN ELECTRIC CO. CLEVELAND, OHIO U.S.A. 9-11-92	S20324

V300-PRO



POWER INPUT CONNECTION

Connect terminal marked  to earth ground per any existing local or national electrical codes.

Single Phase Input

Connect the supply lines to the upper and lower terminals of the line switch. Torque to 27.5in.-lbs.(3.0 Nm). Do not use center terminal of the line switch.

Three Phase Input

Connect the supply lines to the line switch. Torque to 27.5in.-lbs.(3.0 Nm).

Install in accordance with all local and national electric codes.

The V300-PRO is supplied with one cord connector to provide strain relief for the input power cord. It is designed for a cord diameter of .310-1.070" (7.9 - 27.2mm). The jacketed portion of the cord must go through the connector before tightening the connector screws.

Recommended Fuse Sizes Based On The U.S. National Electrical Code And Maximum Machine Outputs

	Input Volts ⁽¹⁾	Fuse Size in Amps (Time Delay Fuses)
3 phase 50/60 Hz	208	60
	230	60
	460	40
	575	25
1 phase 50/60 Hz	208	85
	230	80
	460	50

⁽¹⁾ Input voltage must be within $\pm 10\%$ of rated value.

CONNECTION OF WIRE FEEDERS TO THE INVERTEC

LN-25 Connection Instructions

1. Turn the Invertec power switch "off".
2. Connect the electrode cable to the output terminal of polarity required by electrode. Connect the work lead to the other terminal.
3. LN-25 with remote control options K431 and K432. Use K876 adapter with K432 cable or modify K432 cable with K867 universal adapter plug. See connection diagram S19899 and S19309 or S19405 in Operator's Manual.
4. Place the local-remote switch in the "remote" position if output control is desired at the wire feeder rather than the Invertec. (LN-25 must have K431 and K432 options for remote output control operation).

LN-7 Connection Instructions (not applicable to IEC machines with only 42V Aux.)

1. Turn the Invertec power switch "off".
2. Connect the K480 or K1818-10 control cable from the LN-7 to the Invertec control cable connector. The control cable connector is located at the rear of the Invertec.
3. Connect the electrode cable to the output terminal of polarity required by electrode. Connect the work lead to the other terminal.
4. Place the local-remote switch in the "local" position to allow output control at the Invertec. (K864 remote control adapter and K857 remote control are required for remote output control. See connection diagram S19901.
5. Set the meter polarity switch on the rear of the Invertec to coincide with wire feeder polarity used. The wire feeder will now display the welding voltage.
6. If a K480 or K1818-10 is not available, see connection diagram S19404 for modification of K291 or K404 LN-7 input cable with K867 universal adapter plug..

V300-PRO



LN-9 GMA Connection Instructions (Not applicable to machines with only 42V Aux.)

1. Turn the Invertec power switch "off".
2. Connect the K596 or K1820-10 control cable assembly from the LN-9 GMA to the Invertec control cable connector. The control cable connector is located at the rear of the Invertec.
3. Connect the electrode cable to the output terminal of polarity required by electrode. Connect the work lead to the other terminal.
4. Place the local-remote switch in the "remote" position to allow output control at the LN-9 GMA.
5. Set the meter polarity switch on the rear of the Invertec to coincide with wire feeder polarity used. The wire feeder will now display the welding voltage.
6. K608-1* adapter is required in LN-9 GMA for LN-9 type control. K608-1 is installed in line with P10. See connection diagram S20607.
7. K442-1* Pulse Power Filter Board is also required for GMAW, but should be removed for FCAW.
8. If K596 is not available, see connection diagram S20608 for modification of K196 LN-9 GMA input cable with K867 universal adapter plug.

* These kits are no longer available.

GENERAL INSTRUCTIONS FOR CONNECTION OF WIRE FEEDERS TO INVERTEC

Wire feeders other than LN-7 and LN-25 may be used provided that the auxiliary power supply capacity of the Invertec is not exceeded. K867 universal adapter plug is required. See connection diagram S19406 and S19386 for more information.

Remote Control of Invertec

Remote control K857, hand amptrol K963 and foot amptrol K870 require K864 remote control adapter. See connection diagram S19309.

K954-1 MIG PULSER

The MIG Pulser is a hand-held "pendant" type GMAW Pulsing option for the V300-PRO Power Source. See the Mig Pulser's IM manual (IM555) for connection information.

K900-1 DC TIG STARTER CONNECTION

This versatile new kit was made to mate with the Invertec

A control cable assembly is supplied with the kit to connect the kit to an Invertec. The cable can be connected, either end, at the DC TIG Starter kit and at the Invertec by attaching to the 14-pin Amphenols on the backs of each unit. See diagram S20405.

A negative output cable assembly is also supplied with the DC TIG Starter kit to connect the kit with the Invertec's negative output terminal.

All Magnum™ one and two piece water-cooled torches with 7/8 left-hand threads and gas-cooled torches with 7/8 and 5/16 right-hand threads can be connected to the starter kit.

To secure the DC TIG Starter kit to the bottom of the Invertec and for more detailed instructions, see the K900-1 (IM465) manual.

PARALLEL OPERATION

The Invertec is operable in parallel in both CC and CV modes. For best results, the currents of each machine should be reasonably well shared. As an example, with two machines set up in parallel for a 400 amp procedure, each machine should be set to deliver approximately 200 amps, not 300 amps from one and 100 amps from the other. This will minimize nuisance shutdown conditions. In general, more than two machines in parallel will not be effective due to the voltage requirements of procedures in that power range.

To set machine outputs, start with output control pots and arc force/pinch pots in identical positions. If running in a CC mode, adjust output and arc force to maintain current sharing while establishing the proper output current. In CV modes, set the pots to identical positions. Then switch the machine meters to read amps and adjust one of the output control pots for current balance. Check the voltage and if readjustment is necessary, repeat the current balancing step. Pinch settings should also be kept identical on the machines.

V300-PRO



OUTPUT CABLES

Select the output cable size based upon the following chart.

Cable sizes for Combined Length of Electrode and Work Cable (Copper) 75° rated:

Duty Cycle	Current	Length Up 61m (200 ft.)	61-76m (200-250 ft.)
100%	250	1/0	1/0
60%	300	1/0	2/0

QUICK DISCONNECT PLUGS (K852-7)

A quick disconnect system is used for the welding cable connections. The welding plug included with the machine is designed to accept a welding cable size of 1/0 to 2/0.

1. Remove 1 inch (25mm) of welding cable insulation.
2. Slide rubber boot on to the cable end. The boot end may be trimmed to match the cable diameter. Soap or other lubricant will help to slide the boot over the cable.
3. Slide the copper tube into the brass plug.
4. Insert the cable into the copper tube.
5. Tighten set screw to collapse copper tube. The screw must apply pressure against welding cable. The top of the set screw will be well below the surface of the brass plug after tightening.
6. Slide the rubber boot over the brass plug. The rubber boot must be positioned to completely cover all electrical surfaces after the plug is locked into the receptacle.

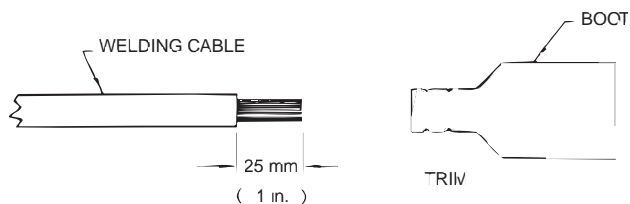

reverse 25mm & 1in

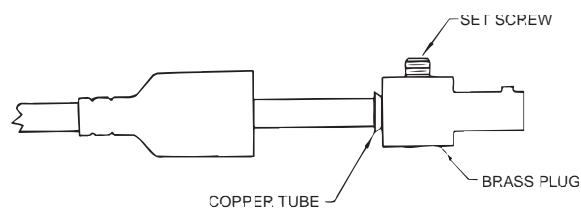

TABLE OF CONTENTS - OPERATION SECTION -

Return to Master TOC

Return to Master TOC

Return to Master TOC

Return to Master TOC

OperationSection B

Operating Instructions B-2
 Controls and Settings B-2, B-4
 Auxillary Power B-4

V300-PRO



OPERATING INSTRUCTIONS

WARNING



ELECTRIC SHOCK can kill.

- Do not touch electrically live parts or electrode with skin or wet clothing.
- Insulate yourself from work and ground.
- Always wear dry insulating gloves.



FUMES AND GASES can be dangerous.

- Keep your head out of fumes.
- Use ventilation or exhaust to remove fumes from breathing zone.

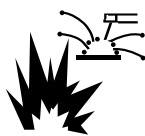

WELDING SPARKS can cause fire or explosion.

- Keep flammable material away.
- Do not weld on closed containers.



ARC RAYS can burn eyes and skin.

- Wear eye, ear and body protection.

See additional warning information at front of this operator's manual.

DUTY CYCLE

The Invertec is rated at 300 amps, 60% duty cycle for 3 phase inputs (based on a 10 minute cycle). It is also rated at 250 amps, 100% duty cycle.

CONTROL FUNCTION / OPERATION

POWER SWITCH - Place the lever in the "ON" position to energize the machine. When the power is on, the digital meter will activate and the fan will operate.

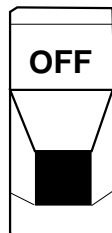

OUTPUT CONTROL - This controls the output voltage in the CV modes and output current in the CC modes.

Control is provided over the entire output range of the power source with 1 turn of the control knob. This control may be adjusted while under load to change power source output.

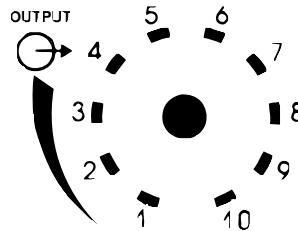

LOCAL/REMOTE SWITCH - Place in the "LOCAL" position to allow output adjustment at the machine. Place in the "REMOTE" position to allow output adjustment at the wire feeder or with a remote control option package.



DIGITAL METER SWITCH - Select either "A" for amps or "V" for volts to display welding current or voltage on the meter.

When welding current is not present, the meter will display the set current for the CC modes or the set voltage for the CV modes. This set reading is an indication of machine control setting. For a more precise process reading, read meter during actual welding.

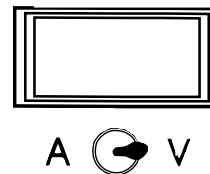

Return to Section TOC
Return to Master TOC

MODE SWITCH

- GTAW** Optimized for both scratch start and Hi-Freq kit use.
- CC SOFT** Best for EXX18 thru EXX28 stick electrodes.
- CC Crisp** Use this mode for stick welding with EXX10 thru EXX14 electrodes. Non-welding applications such as resistive heating or output tests with resistive loads should be done in this mode with Arc Force Control set to minimum.
- CV FCAW** This setting has been optimized for Innershield® and Outershield® flux-cored electrodes.
- CV GMAW** Short circuit, glob and spray transfer solid wire and gas welding are done in this mode. Low end procedures, less than 16V, may operate better in the FCAW mode.

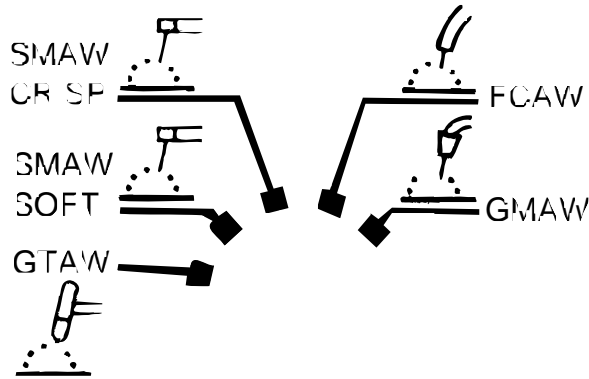

OUTPUT TERMINALS SWITCH

For processes and equipment that require energized machine terminals (stick, TIG, air-carbon arc cutting or hot tip LN-25), set the Output Terminals Switch to “ON” position.

Set to the REMOTE (OFF) position when using LN-25 with K431/K432 or K624-1 options or other wirefeeders which allow the gun trigger to energize the welding terminals.

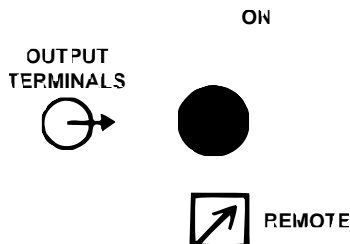

ARC FORCE/INDUCTANCE CONTROL

This control functions in all modes except GTAW. For CC modes, this control acts as an Arc Force adjustment. The arc is soft at the minimum settings and more forceful or driving at the maximum settings. Higher spatter levels may be present at the maximum settings.

For CV modes, this control will set the degree of “pinch effect” which predominantly affects short circuit transfer. In FCAW, the maximum setting is generally preferred. With GMAW, the upper half of the range is preferred with CO₂ or high content CO₂ mixed gas. The **lower half is for inert gas mixes.**

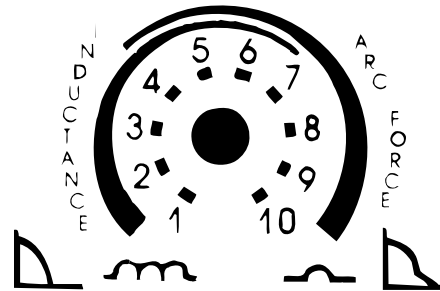

RECOMMENDED SETTINGS FOR SELECTED APPLICATIONS
Full Range Is 1-10,
1 Is Very Soft, 10 Is Very Crisp

Mode	Process	Nominal Setting	Recommended Adjustment Range
CC SMAW 1	EXX18 thru EXX28 stick	5	1 (gentle, may stick) to 9 (forceful, more spatter)
CC SMAW 2	EXX10 thru EXX14 stick	6	3 to 10
	Air Carbon Arc Cutting	1	None
CV FCAW	Innershield or Outershield	10	None
	Air Carbon Arc Cutting	1	None
CV GMAW*	CO ₂ or 25% CO ₂ or similar gas mixes	7.5	5 to 10
	98% Ar-2% O ₂ Ar, 90% He-7.5% Ar 2.5% CO ₂ and other predominantly inert gases	5	1 to 10

* 1 = Lowest pinch, highest inductance and least spatter.
10 = Highest pinch, lowest inductance and most spatter.

Return to Section TOC

Return to Master TOC

Return to Section TOC

Return to Master TOC

Return to Section TOC

Return to Master TOC

Return to Section TOC

Return to Master TOC

TABLE OF CONTENTS - ACCESSORIES SECTION -

AccessoriesSection C

Options/Accessories.....C-2

Return to Master TOC

Return to Master TOC

Return to Master TOC

Return to Master TOC

V300-PRO



OPTIONS / ACCESSORIES

CABLE PLUGS

Cable Plug Kit for 1/0-2/0 cable (K852-70) attaches to welding cable to provide quick disconnect from machine.

Cable Plug Kit for 2.0-3/0 cable (K852-95).

NOTE: Two K852-70 plugs are included with the V300-I.

K864 REMOTE CONTROL ADAPTER

Plugs into the 14-pin receptacle on the rear panel of the Invertec. Adapter splits remote control circuitry to a 6-pin receptacle and to a 14-pin receptacle. Adapter permits remote output control of Invertec by means of K857 Remote Control, K812 Hand Amptrol or K870 Foot Amptrol. Allows remote while using LN-7 K480-7 control cable.

K867 UNIVERSAL ADAPTER PLUG

Consisting of a 14-pin plug connected to labeled wires, the adapter allows user connection of any suitable accessory or wire feeder to the remote control, contactor, and auxiliary power circuitry of the Invertec.

K876 REMOTE CONTROL ADAPTER

For operating an LN-25 wire feeder. The adapter connects to the 14-pin receptacle of Invertec power sources and to the 6-pin connector of the LN-25 K432 remote control cable.

K900-1 DC TIG STARTER

Solid state GTAW starting unit. Rated 300 A, 60%.

V300-PRO



TABLE OF CONTENTS - MAINTENANCE SECTION -

Return to Master TOC

Return to Master TOC

Return to Master TOC

Return to Master TOC

MaintenanceSection D

Input Filter Capacitor Discharge Procedure	D-2
Preventive maintenance.....	D-3
Overload/Thermal Protection	D-3
Printed Circuit Board Replacement.....	D-3

⚠ WARNING



Failure to follow this capacitor discharge procedure can result in electric shock.

INPUT FILTER CAPACITOR DISCHARGE PROCEDURE

1. Turn off input power or disconnect input power lines.
2. Remove 14 5/16" hex head screws from side and top of machine (6 screws on each side and 2 screws on top) and remove wrap-around machine cover.
3. Be careful not to make contact with the capacitor terminals that are located in the center of the Switch Boards.
4. Obtain a high resistance and high wattage resistor (25-1000 ohms and 25 watts minimum). This resistor is not supplied with machine. NEVER USE A SHORTING STRAP FOR THIS PROCEDURE.
5. Locate the two capacitor terminals (large hex head capscrews) shown in Figure D.1.
6. Use electrically insulated gloves and insulated pliers. Hold body of the resistor and connect resistor leads across the two capacitor terminals. Hold resistor in place for 10 seconds. DO NOT TOUCH CAPACITOR TERMINALS WITH YOUR BARE HANDS.
7. Repeat discharge procedure for capacitor on other side of machine. If you are working on a 575 VAC machine, repeat discharge procedure for second capacitor on each side of machine.
8. Check voltage across terminals of all capacitors with a DC voltmeter. Polarity of capacitor terminals is marked on PC board above terminals. Voltage should be zero. If any voltage remains, repeat this capacitor discharge procedure.

FIGURE D.1 — LOCATION OF INPUT FILTER CAPACITOR TERMINALS.

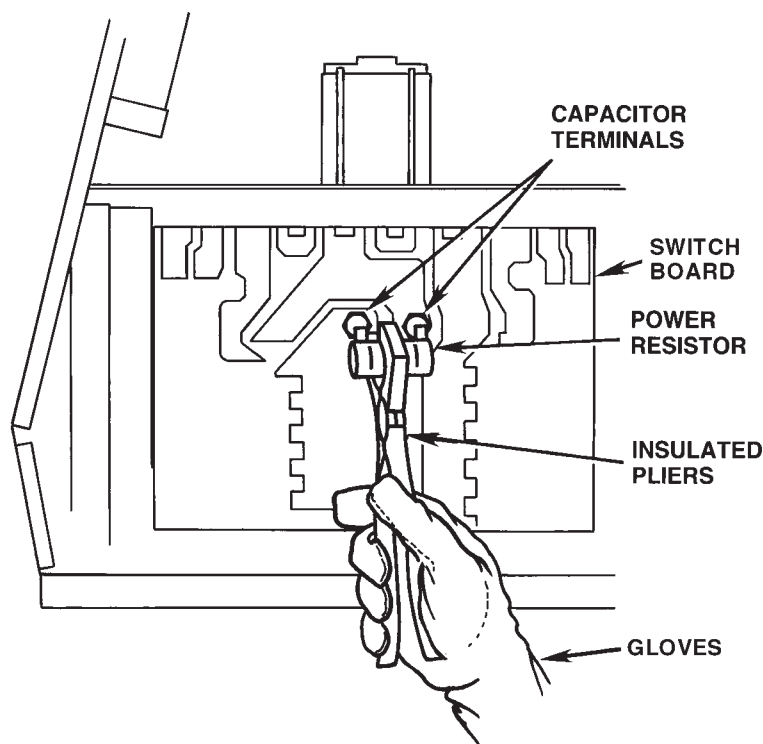

V300-PRO

LINCOLN
ELECTRIC

PREVENTIVE MAINTENANCE

1. Perform the following preventive maintenance procedures at least once every six months. It is good practice to keep a preventive maintenance record; a record tag attached to the machine works best.
2. Remove the machine wrap-around cover and perform the input filter capacitor discharge procedure (detail at the beginning of this chapter).
3. Clean the inside of the machine with a low pressure airstream. Be sure to clean the following components thoroughly. See Figure D.2 for location of these components.
 - Power Switch, Driver, Protection, and Control printed circuit boards
 - Power Switch
 - Main Transformer
 - Input Rectifier
 - Heat Sink Fins
 - Input Filter Capacitors
 - Output Terminals
4. Examine capacitors for leakage or oozing. Replace if needed.
5. Examine wrap-around cover for dents or breakage. Repair as needed. Cover must be kept in good condition to assure high voltage parts are protected and correct spacings are maintained.
6. Check electrical ground continuity. Using an ohmmeter, measure resistance between either output stud and an unpainted surface of the machine case. (See Figure D.2 for locations.) Meter reading should be 500,000 ohms or more. If meter reading is less than 500,000 ohms, check for electrical components that are not properly insulated from the case. Correct insulation if needed.
7. Replace machine cover and screws.

OVERLOAD PROTECTION

The machine is electrically protected from producing high output currents. Should the output current exceed 340-360A, an electronic protection circuit will reduce the current ("Fold Back") to approximately 150A. The machine will continue to produce this low current until the protection circuit is reset. Reset occurs when the output load is removed.

THERMAL PROTECTION

Thermostats protect the machine from excessive operating temperatures. Excessive temperatures may be caused by a lack of cooling air or operating the machine beyond the duty cycle and output rating. If excessive operating temperature should occur, the thermostat will prevent output voltage or current. The meter will remain energized during this time.

PC BOARD REPLACEMENT

1. Handle PC Boards by edges only.
2. Store PC Boards only in the bags that disperse static charges.
3. Inspect PC Board for burned conductors or components. If damage is visible, inspect the machine wiring for grounds or shorts to avoid damaging a new PC Board.
4. If there is no visible damage to the PC Board, install a new PC Board and see if the problem is fixed. If the problem is fixed by the new board, reinstall the old board and see if the problem reoccurs. If the problem does not reoccur, check the wiring harness and plugs for loose connections.

V300-PRO



FIGURE D.2 — LOCATION OF MAINTENANCE COMPONENTS.

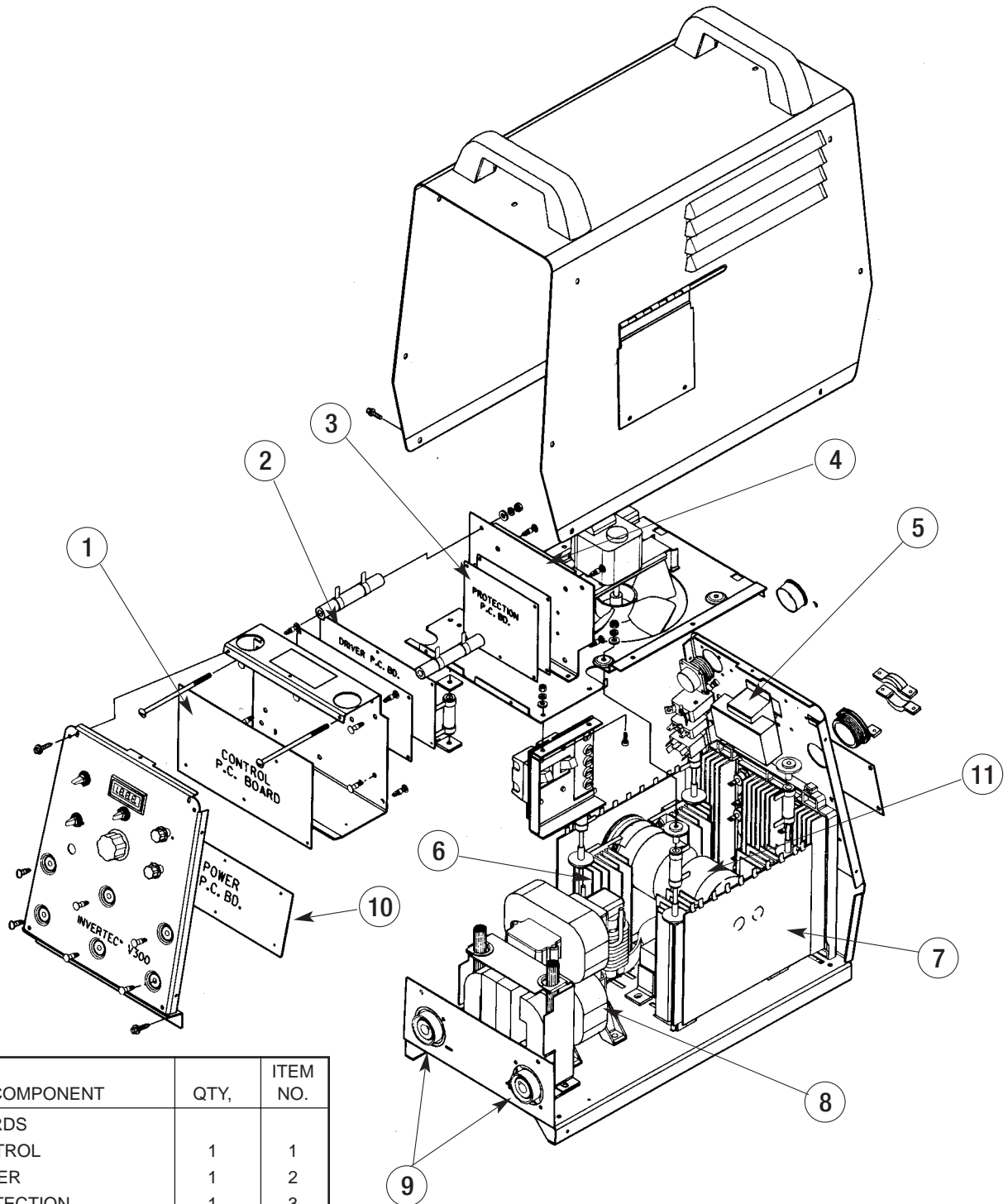

COMPONENT	QTY,	ITEM NO.
PC BOARDS		
CONTROL	1	1
DRIVER	1	2
PROTECTION	1	3
SWITCH	2	7
POWER	1	10
INPUT RECTIFIER	1	4
POWER SWITCH	1	5
HEAT SINK FINS	2	6
MAIN TRANSFORMER	1	8
OUTPUT STUDS	1	9
INPUT FILTER CAPACITORS	2	11

V300-PRO



Return to Section TOC

Return to Section TOC

Return to Section TOC

Return to Section TOC

Return to Master TOC

Return to Master TOC

Return to Master TOC

Return to Master TOC

TABLE OF CONTENTS - THEORY OF OPERATION SECTION -

Return to Master TOC

Return to Master TOC

Return to Master TOC

Return to Master TOC

Theory of OperationSection E

Power Supply OperationE-2

Pre Charge and Protection CircuitryE-3

Switch Board and Main Transformer.....E-4

Control and Output CircuitryE-5

Field Effect Transistor (FET) OperationE-6

Pulse Width ModulationE-7

Protective CircuitsE-8

FIGURE E.1 – V300-PRO BLOCK LOGIC DIAGRAM

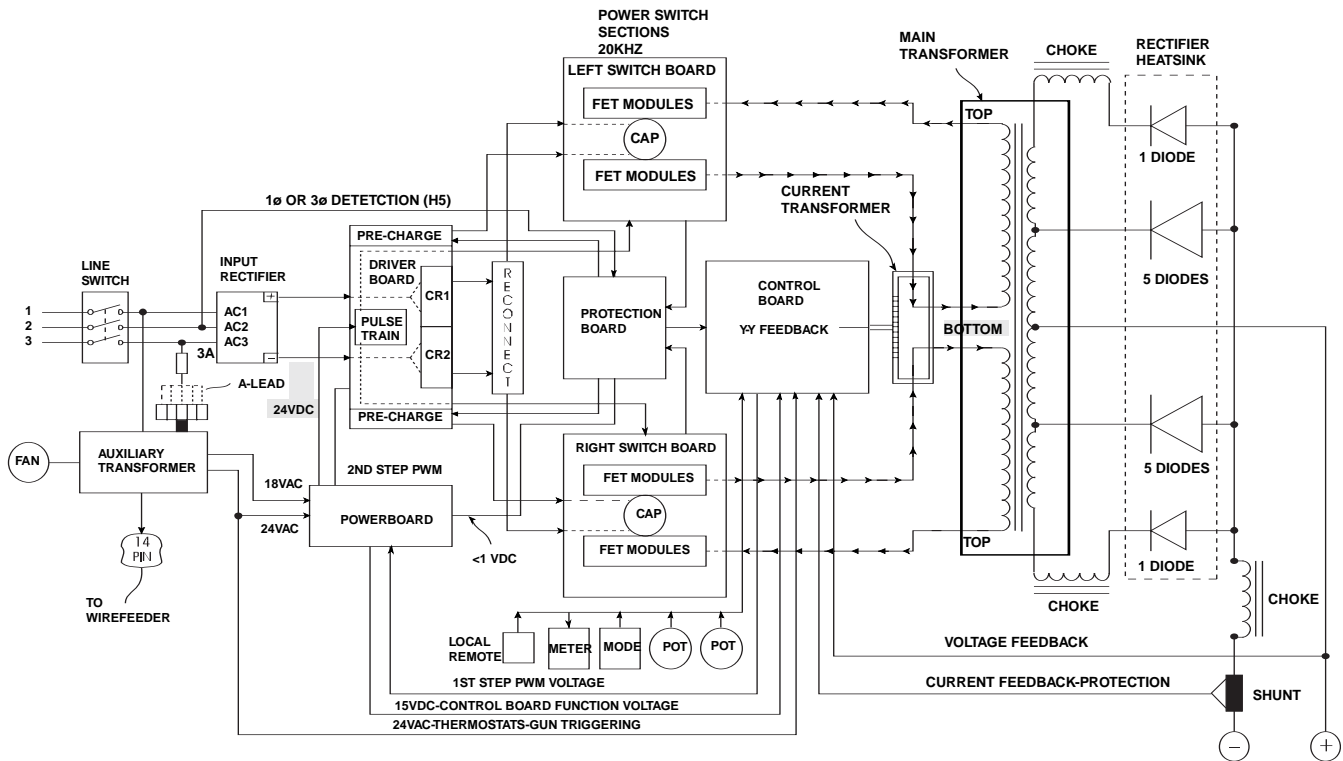
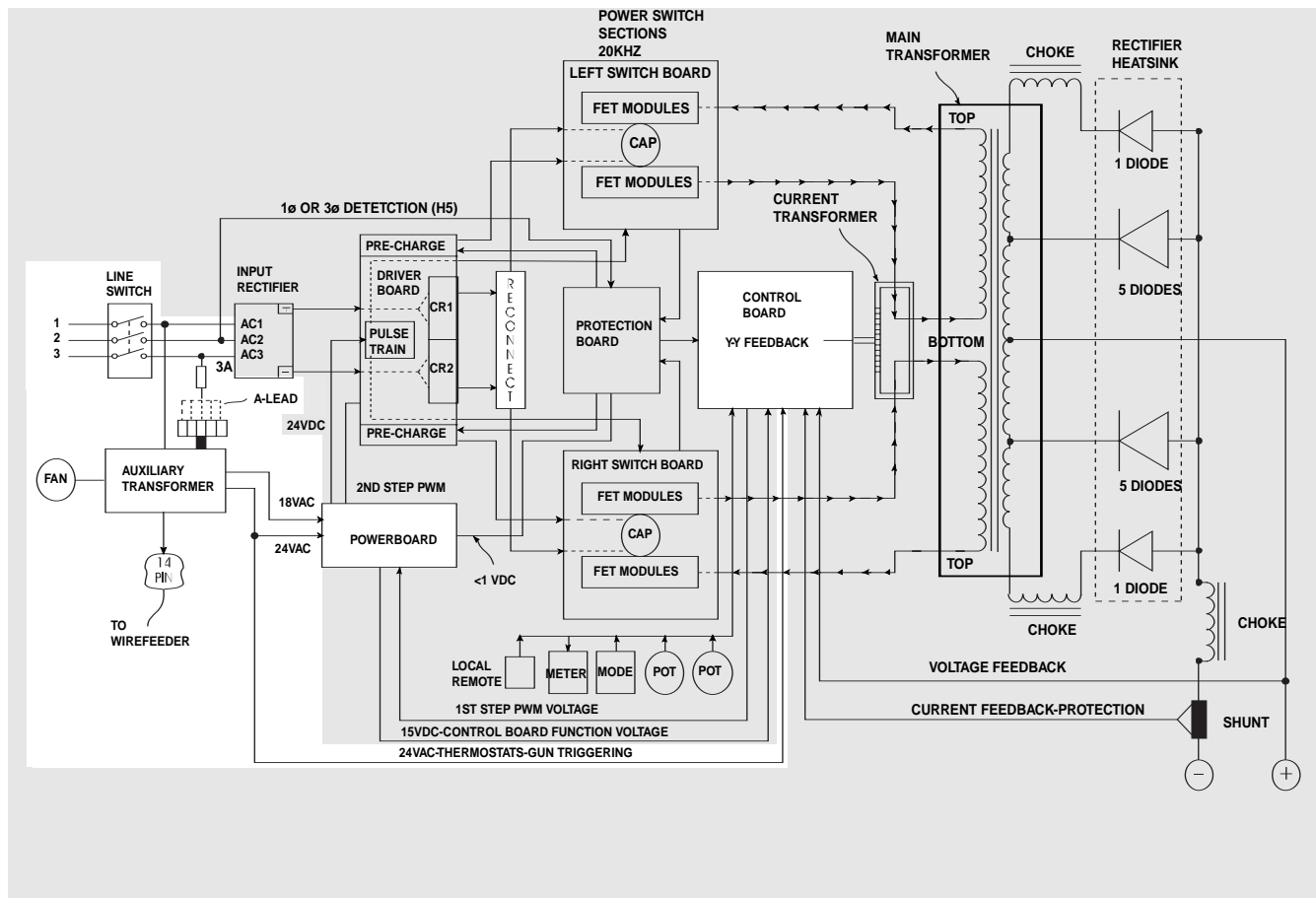

FIGURE E-2 --- INPUT CIRCUITS



INPUT LINE VOLTAGE & AUXILIARY TRANSFORMER

The V300-PRO can be connected for a variety of three phase or single phase input voltages. Power is applied through the Line Switch to the Input Rectifier and the Auxiliary Transformer.

The Reconnect Panel has switches to select high or low operating voltage. The "A" lead must then be set for the proper input voltage. It is important to set the switches and "A" lead to the proper positions before applying input power. **Changing the switch position with the power applied will result in major damage to the machine**

The auxiliary transformer provides 18v.a.c. and 24v.a.c. supplies to the Control and Power Boards. It also provides 115v.a.c., 42v.a.c. and 24v.a.c. supplies to the wirefeeder amphenol. (CE machines do not have 115v.a.c. supply)

The Power Board provides a 15v.d.c. supply to the Control Board and a 24v.d.c. supply to the Driver Board to operate the Pre-charge Relays.

NOTE: Unshaded areas of block logic diagram are the subject of discussion

V300-PRO

LINCOLN
ELECTRIC

FIGURE E-3 ---PRECHARGE & PROTECTION CIRCUITS

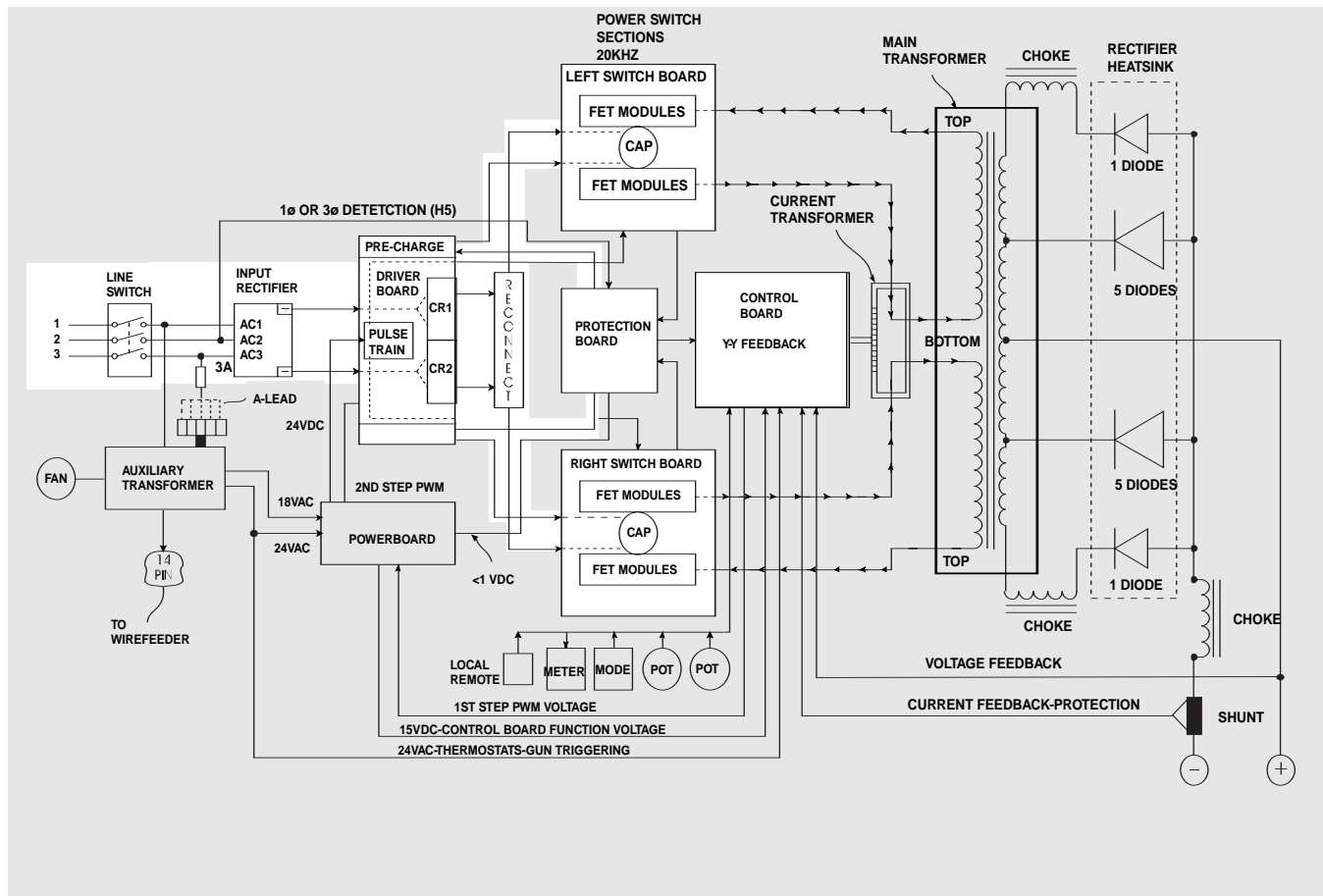

PRECHARGE & PROTECTION CIRCUITS

The DC voltage from the Input Rectifier is applied to the Driver Board to begin charging the Switch Board capacitors at a slow rate. When the pre-charge level is achieved, the input relays close, applying the full DC voltage to the capacitors. Depending on the Code Number of the machine, there will be either two or four relays and they may or may not be mounted on the Driver Board.

The Driver Board is also responsible for gating the Field Effect Transistors (FETs) on the Switch Boards, as directed by the pulse width modulated (PWM) signal from the Control Board.

The Protection Board monitors the capacitors for proper balance and voltage level. If an imbalance or over-voltage condition is detected, the Protection Circuit will de-energize the relays, removing the power from the switch circuits. The machine output will also be disabled.

Another function of the Protection Board is to detect whether the input voltage is single phase or three phase and pass that information to the Control Board. The maximum output of the machine will be limited to approximately 250 amps with single phase input and 360 amps with 3 phase input.

NOTE: Unshaded areas of block logic diagram are the subject of discussion

Return to Section TOC
 Return to Master TOC
 Return to Section TOC
 Return to Master TOC
 Return to Section TOC
 Return to Master TOC
 Return to Section TOC
 Return to Master TOC

FIGURE E-4 ---SWITCH CIRCUITS & TRANSFORMER

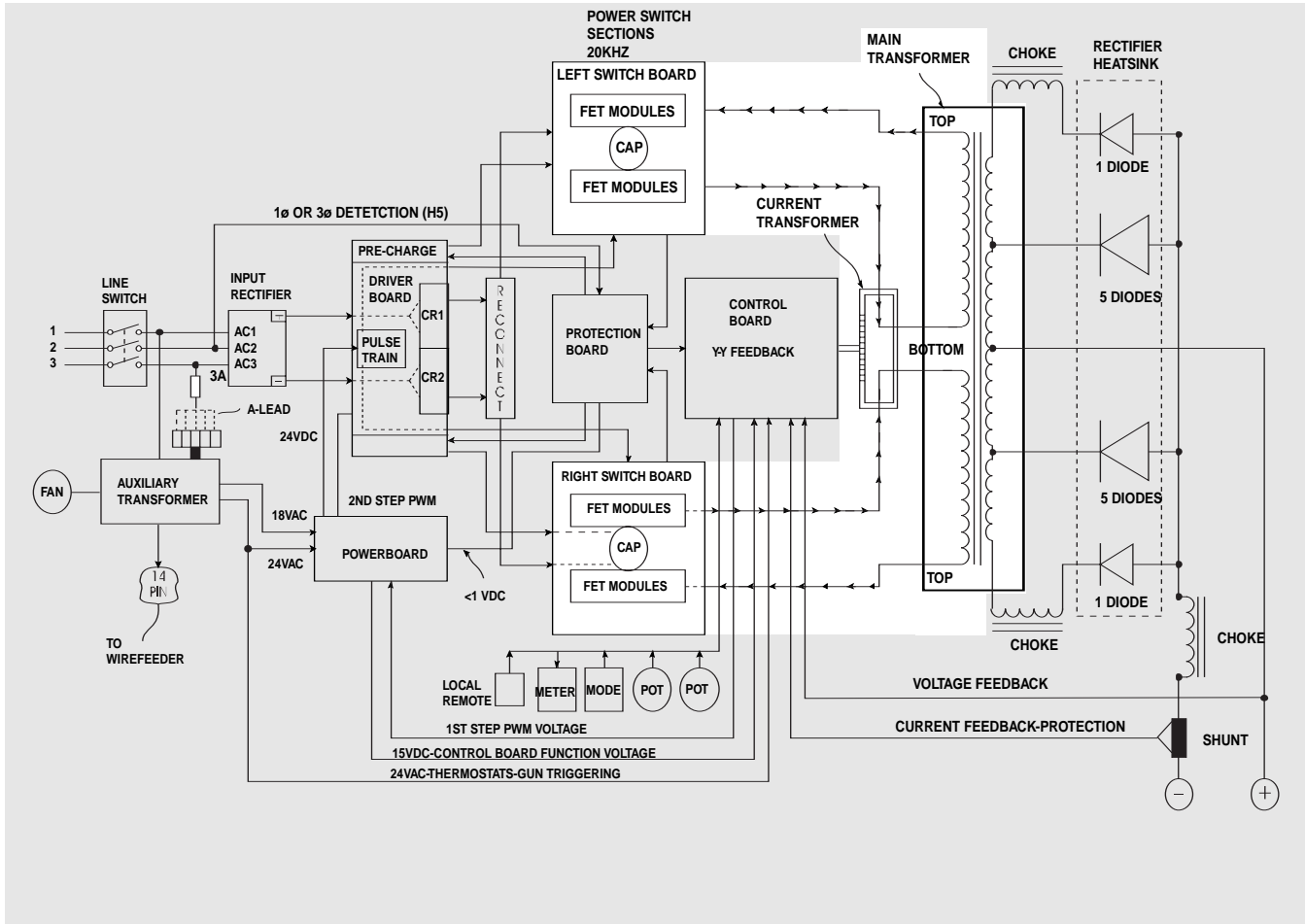

SWITCH BOARDS

The Switch Boards contain the the Field Effect Transistors (FETs) which, when switched ON, supply power to the primary windings of the main transformer. Each Switch Board powers a separate, oppositely wound primary winding. The opposite direction of current flow in those windings and a slight offset in of the FET switching produces a square wave AC signal in the secondary of the transformer.

The DC current of the primaries is clamped back to the respective capacitors through diodes on the board when the FETs turn off. This protects against inductive voltage spikes due to the inductance of the windings and also helps maintain capacitor balance.

The boards are fired during a 50 microsecond interval with respect to a Pulse Width Modulated (PWM) signal from the Control Board through the Driver Board. This creates a constant 20Khz output in the secondary.

NOTE: Unshaded areas of block logic diagram are the subject of discussion

Along with ease of control, the 20Khz operating frequency allows for a much smaller and lighter transformer

Signals from the Current Transformer insure that one switch circuit is turned off before the other is gated on.

Field Effect Transistor operation and Pulse Width Modulation are discussed in more detail later in this section.

FIGURE E-5 --OUTPUT & CONTROL CIRCUITS

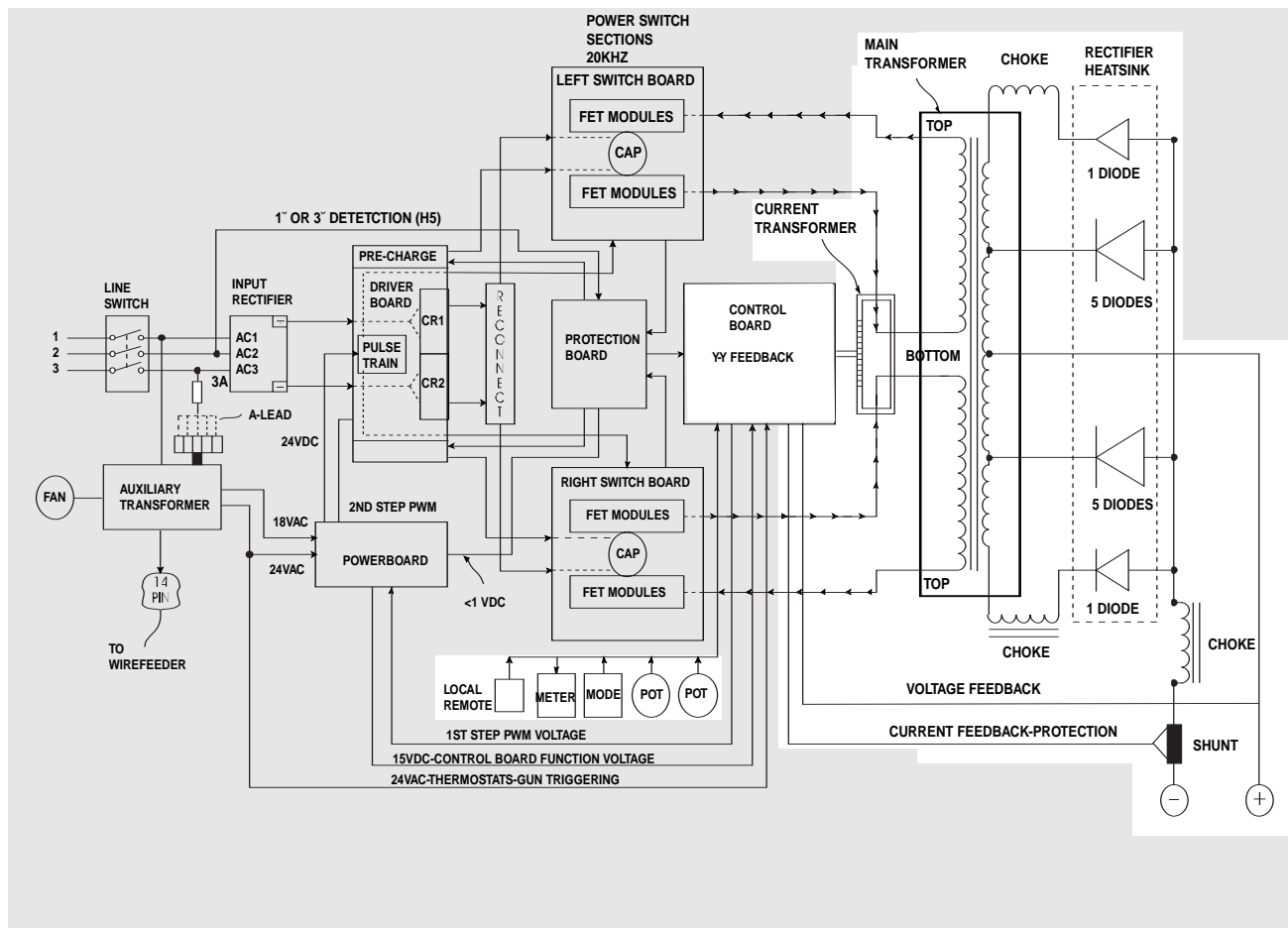

OUTPUT AND CONTROL CIRCUITS

The AC output of the transformer is changed to DC by the Output Rectifier. The Output Choke between the negative side of the rectifier and the negative output stud provides the necessary filtering for DC welding. The two smaller chokes and their series diodes are the OCV boost circuit used to help provide good weld starts.

Current feedback to the Control Board is provided by the shunt in the negative output circuit. It is used for weld control, overcurrent protection and actual ammeter readings. The Voltage feedback lead at the positive output stud also provides information for weld control and actual voltmeter readings.

The Control Board monitors input from the front panel controls (output, arc control, mode switch, etc.). The software on the board processes these inputs, sets up the proper weld information and sends the "set" parameter information to the meter.

When weld output is requested, the Control Board compares the input information to the feedback signals and provides the correct PWM signals to the Switch Boards for optimum welding. The Mode Switch setting determines which feedback signal (voltage or current) will have the most relevance. However, both signals are used in all modes.

The Control Board also monitors signals from the thermostats and the Protection Board and if necessary, shuts off the weld output. The protection circuit information is discussed in more detail later in this section.

NOTE: Unshaded areas of block logic diagram are the subject of discussion

V300-PRO

LINCOLN
ELECTRIC

FIELD EFFECT TRANSISTOR OPERATION

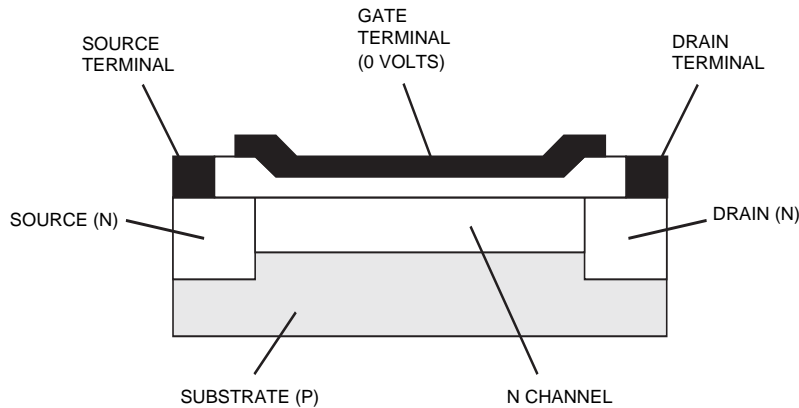

A. PASSIVE

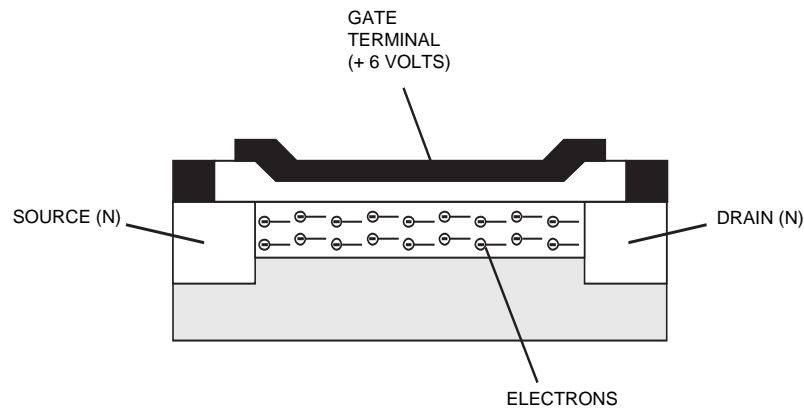

B. ACTIVE

An FET is a type of transistor. FETs are semiconductors well suited for high-frequency switching because they are capable of going from full off to full on much more quickly than other types of semi-conductors.

Drawing A above shows an FET in a passive mode. There is no gate signal, zero volts relative to the source and, therefore, no current flow. The drain terminal of the FET may be connected to a voltage supply; but since there is no conduction, the circuit will not supply current to downstream components connected to the source. The circuit is turned off like a light switch in the OFF position.

Drawing B above shows the FET in an active mode. When the gate signal, a positive DC voltage relative to the source, is applied to the gate terminal of the FET, it is capable of conducting current. A voltage supply connected to the drain terminal will allow the FET to conduct and henceforth supply current to downstream components. Current will flow through the conducting FET to downstream components as long as the gate signal is present. This is similar to turning on a light switch.

PULSE WIDTH MODULATION

FIGURE E.6 — TYPICAL FET OUTPUTS.

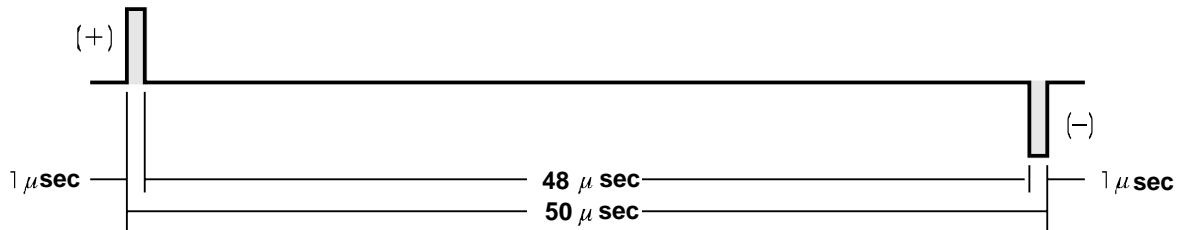

MINIMUM OUTPUT

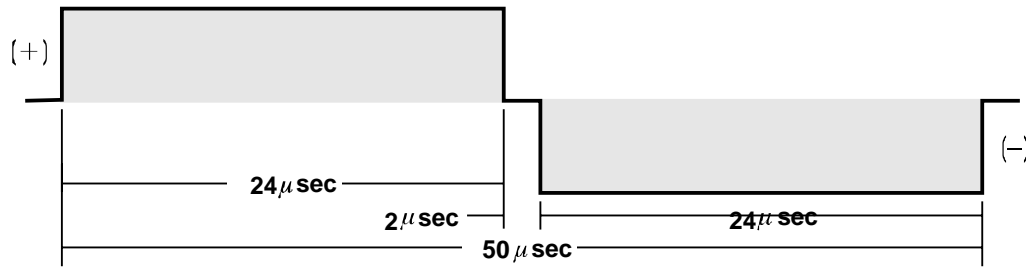

MAXIMUM OUTPUT

The term PULSE WIDTH MODULATION is used to describe how much time is devoted to conduction in the positive and negative portions of the cycle. Changing the pulse width is known as MODULATION. Pulse Width Modulation (PWM) is the varying of the pulse width over the allowed range of a cycle to affect the output of the machine.

MINIMUM OUTPUT

By controlling the duration of the gate signal, the FET is turned on and off for different durations during a cycle. The top drawing above shows the minimum output signal possible over a 50-microsecond time period.

The positive portion of the signal represents one FET group¹ conducting for 1 microsecond. The negative portion is the other FET group¹. The dwell time (off time) is 48 microseconds (both FET groups off).

Since only 2 microseconds of the 50-microsecond time period is devoted to conducting, the output power is minimized.

MAXIMUM OUTPUT

By holding the gate signals on for 24 microseconds each and allowing only 2 microseconds of dwell time (off time) during the 50-microsecond cycle, the output is maximized. The darkened area under the top curve can be compared to the area under the bottom curve. The more dark area under the curve, the more power is present.

¹ An FET group consists of the sets of FET modules grouped onto one switch board.

PROTECTIVE CIRCUITS

Protective circuits are designed into the Invertec machine to sense trouble and shut down the machine before the trouble damages the internal machine components. Both overload and thermal protection circuits are included.

OVERLOAD PROTECTION

The machine is electronically protected from producing excessive output current. Should the output current exceed 340 to 360 amps, an electronic protection circuit will reduce the current to approximately 150 amps. Lincoln Electric refers to this current reduction as "Fold Back." The machine will continue to produce this low current until the protection circuit is reset by removing the load.

Another protection circuit is included to monitor the voltage across input filter capacitors. In the event that the capacitor voltage is too high, the protection circuit will signal the Control Board to prevent output. The protection circuit may prevent output, if any of these circumstances occur:

1. Capacitor conditioning is required
(Required if machine has been off for prolonged periods of time.)
2. Line surges over 500 VAC
3. Internal Component damage
4. Improper connections

THERMAL PROTECTION

Thermostats protect the machine from excessive operating temperatures. Excessive temperatures may be caused by a lack of cooling air or by operating the machine beyond its duty cycle or output rating. If excessive operating temperature should occur, the thermostat will open and prevent output. The meter will remain on during this time. Thermostats will normally self-reset once the machine cools sufficiently.

If the thermal shutdown was caused by excessive output or duty cycle and the fan is operating normally, the Power Switch may be left on and the reset should occur within a 15-minute period. If the fan is not turning or the air intake louvers were obstructed, then the power must be switched off for 15 minutes in order to reset. The fan problem or air obstruction must also be corrected.

TABLE OF CONTENTS

- TROUBLESHOOTING & REPAIR SECTION -

Troubleshooting & Repair SectionSection F

How to Use Troubleshooting Guide.....F-2

PC Board Troubleshooting Procedures and Replacement.....F-3

Additional Troubleshooting ProceduresF-4

Troubleshooting Guide.....F-5

Test Procedures

 Input Filter Capacitor Discharge Procedure.....F-11

 Output Pilot Circuit TestF-13

 Protection Board Output Test.....F-17

 Capacitor Balance TestF-21

 Switch Board Test.....F-25

 Snubber Resistor TestF-29

 Output Diode Test.....F-31

 Input Rectifier Test.....F-33

 OverCurrent Protection Current Trigger Test.....F-35

 Overvoltage Protection DC Trigger Circuit TestF-38

 Thermal Protection AC Trigger Circuit.....F-43

 Power Board TestF-47

Replacement Procedures

 Capacitor ReplacementF-51

 Switch Board ReplacementF-55

 Test After Switch Board or Capacitor ReplacementF-57

 Output Diode ReplacementF-59

 Retest After Any RepairF-62

Return to Master TOC

Return to Master TOC

Return to Master TOC

Return to Master TOC

TROUBLESHOOTING & REPAIR

HOW TO USE TROUBLESHOOTING GUIDE



CAUTION

Service and repair should be performed by only Lincoln Electric Factory Trained Personnel. Unauthorized repairs performed on this equipment may result in danger to the technician and machine operator and will invalidate your factory warranty. For your safety and to avoid Electrical Shock, please observe all safety notes and precautions detailed throughout this manual.

This Troubleshooting Guide is provided to help you locate and repair possible machine malfunctions. Simply follow the three-step procedure listed below.

Step 1. LOCATE PROBLEM (SYMPTOM). Look under the column labeled “PROBLEM (SYMPTOMS)”. This column describes possible symptoms that the machine may exhibit. Find the listing that best describes the symptom that the machine is exhibiting. Symptoms are grouped into categories of typical problems.

Step 2. PERFORM EXTERNAL TESTS. The second column, labeled “POSSIBLE AREAS OF MISADJUSTMENT(S)”, lists the obvious external possibilities that may contribute to the machine symptom. Perform these tests/checks in the order listed. In general, these tests can be conducted without removing the case wrap-around cover.

Step 3. PERFORM COMPONENT TESTS. The last column, labeled “Recommended Course of Action” lists the most likely components that may have failed in your machine. It also specifies the appropriate test procedure to verify that the subject component is either good or bad. If there are a number of possible components, check the components in the order listed to eliminate one possibility at a time until you locate the cause of your problem.

All of the referenced test procedures referred to in the Troubleshooting Guide are described in detail at the end of this chapter. Refer to the Troubleshooting and Repair Table of Contents to locate each specific Test Procedure. All of the referred to test points, components, terminal strips, etc., can be found on the referenced electrical wiring diagrams and schematics. Refer to the Electrical Diagrams Section Table of Contents to locate the appropriate diagram.



CAUTION

If for any reason you do not understand the test procedures or are unable to perform the test/repairs safely, contact the Lincoln Electric Service Department for electrical troubleshooting assistance before you proceed. Call 1-888-935-3877.

V300-PRO



Return to Section TOC
Return to Master TOC
Return to Section TOC
Return to Master TOC
Return to Section TOC
Return to Master TOC
Return to Section TOC
Return to Master TOC
Return to Section TOC
Return to Master TOC

PC BOARD TROUBLESHOOTING PROCEDURES

! WARNING

**ELECTRIC SHOCK
can kill.**

- Have an electrician install and service this equipment. Turn the input power OFF at the fuse box before working on equipment. Do not touch electrically hot parts.

! CAUTION

Sometimes machine failures appear to be due to PC board failures. These problems can sometimes be traced to poor electrical connections. To avoid problems when troubleshooting and replacing PC boards, please use the following procedure:

1. Determine to the best of your technical ability that the PC board is the most likely component causing the failure symptom.
2. Check for loose connections at the PC board to assure that the PC board is properly connected.
3. If the problem persists, replace the suspect PC board using standard practices to avoid static electrical damage and electrical shock. Read the warning inside the static resistant bag and perform the following procedures:

PC board can be damaged by static electricity.

- Remove your body's static charge before opening the static-shielding bag. Wear an anti-static wrist strap. For safety, use a 1 Meg ohm resistive cord connected to a grounded part of the equipment frame.

- If you don't have a wrist strap, touch an un-painted, grounded, part of the equipment frame. Keep touching the frame to prevent static build-up. Be sure not to touch any electrically live parts at the same time.

- Tools which come in contact with the PC board must be either conductive, anti-static or static-dissipative.

- Remove the PC board from the static-shielding bag and place it directly into the equipment. Don't set the PC board on or near paper, plastic or cloth which could have a static charge. If the PC board can't be installed immediately, put it back in the static-shielding bag.
 - If the PC board uses protective shorting jumpers, don't remove them until installation is complete.
 - If you return a PC board to The Lincoln Electric Company for credit, it must be in the static-shielding bag. This will prevent further damage and allow proper failure analysis.
4. Test the machine to determine if the failure symptom has been corrected by the replacement PC board.

NOTE: It is desirable to have a spare (known good) PC board available for PC board troubleshooting. (Some "test" boards are available to Service Facilities through the Parts Department).

NOTE: Allow the machine to heat up so that all electrical components can reach their operating temperature.

5. Remove the replacement PC board and substitute it with the original PC board to recreate the original problem.
 - a. If the original problem does not reappear by substituting the original board, then the PC board was not the problem. Continue to look for bad connections in the control wiring harness, junction blocks, and terminal strips.
 - b. If the original problem is recreated by the substitution of the original board, then the PC board was the problem. Reinstall the replacement PC board and test the machine.
6. Always indicate that this procedure was followed when warranty reports are to be submitted.

NOTE: Following this procedure and writing on the warranty report, "INSTALLED AND SWITCHED PC BOARDS TO VERIFY PROBLEM," will help avoid denial of legitimate PC board warranty claims.

ADDITIONAL INFORMATION

OSCILLOSCOPE WARNING

Do not use oscilloscopes and other pieces of test equipment that are powered by 115 VAC. This equipment should not be used with inverter-type machines, such as Invertec V300-PRO. There are high voltages present, which are “floating” off case ground (floating ground). Connecting the ground lead of a test probe (which may be connected to the case of the test equipment) to a high voltage potential presents a shock hazard as well as the possibility of damage to the equipment in question.

INPUT FILTER CAPACITOR CONDITIONING

Capacitor conditioning may be required if the machine will not produce output after power is applied and the following two conditions exist:

The machine is connected to a supply of 380 v.a.c. or higher

and

Power has not been applied to the machine for an extended period of time (months).

To condition the input filter capacitors:

1. Turn the Power Switch OFF
2. Remove any load and do not load the machine until the capacitor conditioning is completed.
3. Turn the Power Switch ON and leave the machine energized for at least 30 minutes.
4. Cycle the Power Switch OFF and on again .

The machine should now work normally. If not, continue with the Troubleshooting Section of this manual.

MATCHED PARTS

The following parts must be replaced in matched sets:

Output Diodes D1, D2, D3, D4, and D5.

Output Diodes D7, D8, D9, D10, and D11.

Note: On newer codes where Diode Modules are used in place of individual diodes, both modules on a heat sink assembly should be replaced if one fails.

Capacitor Bleeder Resistors: R1 & R9

Capacitors: C1 & C2

Capacitors C1, C2, C14 & C15 on 575 v.a.c. units.

Switch Boards prior to L10598-[]

V300-PRO



TROUBLESHOOTING GUIDE

Observe Safety Guidelines detailed in the beginning of this manual.

PROBLEMS (SYMPTOMS)	POSSIBLE AREAS OF MISADJUSTMENT(S)	RECOMMENDED COURSE OF ACTION
FEEDING PROBLEMS		
Major physical or electrical damage is observed when cover wrap-around is removed.	Contact Lincoln Electric Service Department (1-888-935-3877)	
Machine is dead — no output — no fan — no display.	<p>Power Switch must be in ON position.</p> <p>Check input voltage.</p> <p>If machine is set for single-phase operation, inspect to assure that WHITE and BLACK leads of the Power Cord are connected properly and RED lead is not connected and is insulated.</p> <p>Check that input voltage set-up switch and jumper A (the reconnect, auxiliary jumper) are in proper position for input voltage being used.</p>	<p>Check continuity of 3-amp slow blow fuse located on reconnect panel.</p> <ol style="list-style-type: none"> 1. Check Power Switch (S1). 2. Look for loose or broken wires between Power Switch and Input Rectifier (component D13). 3. Check for broken leads to primary of Auxiliary Transformer T1. 4. Possible open primary coil of Auxiliary Transformer T1.
No output but fan operates and the meter display is on.	<p>Output Terminal Switch or Remote Trigger MUST be in ON position.</p> <p>Local/Remote Switch must be in LOCAL position unless remote control device is attached to remote receptacle.</p> <p>If machine has not been used for a long time and is connected for 380 VAC or higher, Capacitors may need "conditioning." See Input Filter Capacitor Conditioning in this section</p>	<ol style="list-style-type: none"> 1. See Output Pilot Circuit test. 2. See Thermal Protection AC Trigger Circuit test. 3. See Overvoltage Protection DC Trigger Circuit test. 4. See Capacitor Balance test 5. See Switch PC Board test. 6. See Power Board test 7. Look for broken or loose connections on high current-carrying parts of machine (i.e., choke, output bridges, output studs, main transformer.

CAUTION

If for any reason you do not understand the test procedures or are unable to perform the test/repairs safely, contact the Lincoln Electric Service Department for electrical troubleshooting assistance before you proceed. Call 1-888-935-3877.

V300-PRO



Return to Section TOC

Return to Section TOC

Return to Section TOC

Return to Section TOC

Return to Master TOC

Return to Master TOC

Return to Master TOC

Return to Master TOC

TROUBLESHOOTING GUIDE

Observe Safety Guidelines detailed in the beginning of this manual.

PROBLEMS (SYMPTOMS)	POSSIBLE AREAS OF MISADJUSTMENT(S)	RECOMMENDED COURSE OF ACTION
FEEDING PROBLEMS		
No output or reduced output the first time power is applied to machine.	Check input voltages, fuses, and input voltage reconnect procedures. See Installation section. If high input (380 VAC or higher) voltage is applied. Capacitors may need conditioning.	Check continuity of 3-amp slow blow fuse located on reconnect panel. See Input Filter Capacitor Conditioning in this section
Output turns on momentarily, then switches off and repeats cycle.	Check input voltages and reconnection procedures. See Installation section. Check output terminal switch S4 and/or Remote Trigger Options (i.e., wire feeders, guns, cables, etc.).	<ol style="list-style-type: none"> 1. See Thermal Protection AC Trigger Circuit test. 2. See Overvoltage Protection DC Trigger Circuit test. 3. See Capacitor Balance test. NOTE: This test is necessary only if machine is connected for 380 VAC or higher. 4. See Switch PC Board test. 5. See Snubber Resistor test
Remote output control not functioning. Machine performs well on LOCAL control.	Test or replace Output Remote Control Device	<ol style="list-style-type: none"> 1. Test Local/Remote Switch S3 with ohmmeter. See Wiring Diagram in Section G. 2. Check continuity of local/remote circuit. See schematic drawing in Section G.

 **CAUTION**

If for any reason you do not understand the test procedures or are unable to perform the test/repairs safely, contact the Lincoln Electric Service Department for electrical troubleshooting assistance before you proceed. Call 1-888-935-3877.

Return to Section TOC

Return to Section TOC

Return to Section TOC

Return to Section TOC

Return to Master TOC

Return to Master TOC

Return to Master TOC

Return to Master TOC

TROUBLESHOOTING GUIDE

Observe Safety Guidelines detailed in the beginning of this manual.

PROBLEMS (SYMPTOMS)	POSSIBLE AREAS OF MISADJUSTMENT(S)	RECOMMENDED COURSE OF ACTION
FEEDING PROBLEMS		
No output. Main fuses open, indicating excessive current draw.	<p>Inspect input leads for possible shorts or grounds or misconnections.</p> <p>Install new fuses and reapply power. If fuses open again, go to next column of this Guide.</p>	<p>Inspect interior of machine for physical signs of electrical and heat damage. Replace any damaged components after conducting the tests below:</p> <ol style="list-style-type: none"> 1. See Input Rectifier test. 2. See Switch Board test. 3. See Capacitor Balance tests. 4. See Snubber Resistor test.
Machine does not produce more than 250 amps on meter (while welding) when connected to 3-phase supply.	Check input voltages, fuses, and input voltage reconnect procedures. See Installation section of this manual.	<ol style="list-style-type: none"> 1. See Protection Board Output Voltage test. 2. See Control Board test. 3. See Input Rectifier test (component D13).
Machine does not produce more than 250 amps on meter (while welding) while connected to single-phase supply	<p>Normal operation.</p> <p>Nothing is wrong.</p>	No test necessary. The single-phase operation is detected by the Protection Board and the output current is limited accordingly.
Machine operates okay at 230 VAC or lower. No output at 380 VAC or higher	Check input voltage and input voltage reconnect procedures. See Installation section of this manual.	<ol style="list-style-type: none"> 1. Check Re-connect Switches 2. See Protection Board Output test. 3. See Capacitor Balance tests. 4. See Snubber Resistor test. 5. See Switch PC Board test.

**CAUTION**

If for any reason you do not understand the test procedures or are unable to perform the test/repairs safely, contact the Lincoln Electric Service Department for electrical troubleshooting assistance before you proceed. Call 1-888-935-3877.

V300-PRO



TROUBLESHOOTING GUIDE

Observe Safety Guidelines detailed in the beginning of this manual.

PROBLEMS (SYMPTOMS)	POSSIBLE AREAS OF MISADJUSTMENT(S)	RECOMMENDED COURSE OF ACTION
FEEDING PROBLEMS		
Meter reads low voltage (1-2 VDC), and output is extremely low or no output.	Local/Remote Switch must be in LOCAL position unless Remote Control device is attached to remote receptacle.	<ol style="list-style-type: none"> 1. See Output Diodes test. 2. See Capacitor Balance tests. 3. See Switch Board test. 4. See Power Board test. 5. See Control Board test.
Poor welding, weld settings drift, or output power is low.	<p>Check welding procedures and weld cable connections. Check with machine on local control.</p> <p>Check input voltages and input voltage reconnect procedures. See Installation section of this manual.</p>	<ol style="list-style-type: none"> 1. Check Mode Switch S2 for damage and continuity. 2. Check for continuity between Mode Switch S2 and Control Board. See Wiring Diagram in Section G. 3. Check for loose or faulty connections in heavy current-carrying leads (i.e., choke, shunt, output bridge, and output studs). See wiring diagram in Section G. 4. See Overcurrent Protection Current Trigger Circuit tests. 5. See Control Board test
Welding "too hot". Actual weld current is considerably higher than display indicates.	Check condition of the shunt and leads to the Control Board.	<p>See Step 7 of the Overcurrent Protection Current Trigger test</p> <p>If shunt and leads check OK, possible defective Control Board</p>

**CAUTION**

If for any reason you do not understand the test procedures or are unable to perform the test/repairs safely, contact the Lincoln Electric Service Department for electrical troubleshooting assistance before you proceed. Call 1-888-935-3877.

V300-PRO



TROUBLESHOOTING GUIDE

Observe Safety Guidelines detailed in the beginning of this manual.

PROBLEMS (SYMPTOMS)	POSSIBLE AREAS OF MISADJUSTMENT(S)	RECOMMENDED COURSE OF ACTION
FEEDING PROBLEMS		
Poor stick electrode performance. Arc pops out.	Check output welding cables. Is electrode DRY? Try welding with another electrode from a different container. Make sure you have the correct electrode for your application.	1. Check for loose or burned connections at choke, shunt, and output studs. See wiring diagram in Section G. 2. Test and inspect D6, D12, L1 and L2. See Wiring Diagram in Section G.
Machine makes “squealing” noise while under load when welding. Output power is low (less than 20 VDC on meter @ 100 amps). Input voltage 230 VAC or lower.	Check input lines and connections. Check input voltage and reconnection procedures	1. See Switch Board test. 2. See Snubber Resistor test. 3. See Output Diode Test .

CAUTION

If for any reason you do not understand the test procedures or are unable to perform the test/repairs safely, contact the Lincoln Electric Service Department for electrical troubleshooting assistance before you proceed. Call 1-888-935-3877.

Return to Section TOC

Return to Section TOC

Return to Section TOC

Return to Section TOC

Return to Master TOC

Return to Master TOC

Return to Master TOC

Return to Master TOC

Return to Section TOC
Return to Master TOC

Return to Section TOC
Return to Master TOC

Return to Section TOC
Return to Master TOC

Return to Section TOC
Return to Master TOC

V300-PRO



INPUT FILTER CAPACITOR DISCHARGE PROCEDURE



WARNING

Service and repair should be performed by only Lincoln Electric factory trained personnel. Unauthorized repairs performed on this equipment may result in danger to the technician or machine operator and will invalidate your factory warranty. For your safety and to avoid electrical shock, please observe all safety notes and precautions detailed throughout this manual.

If for any reason you do not understand the test procedures or are unable to perform the test / repairs safely, contact the Lincoln Electric Service Department for electrical troubleshooting assistance before you proceed. Call 1-888-935-3877.

TEST DESCRIPTION

This procedure will drain off any charge stored in the capacitors that are part of the Switch Board Assemblies. This procedure **MUST** be performed as a safety precaution before conducting any test or repair that requires you to touch internal components of the machine

MATERIALS NEEDED

- Volt/Ohm Meter (multi-meter)
- Insulated Gloves
- Insulated Pliers
- High Wattage Resistor (25-1000 ohms/25watt)
- Misc. Hand Tools

V300-PRO



INPUT FILTER CAPACITOR DISCHARGE PROCEDURE (cont.)

WARNING



Failure to follow this capacitor discharge procedure can result in electric shock.

INPUT FILTER CAPACITOR DISCHARGE PROCEDURE

1. Turn off input power or disconnect input power lines.
2. Remove 14 5/16" hex head screws from side and top of machine (6 screws on each side and 2 screws on top) and remove wrap-around machine cover.
3. Be careful not to make contact with the capacitor terminals that are located in the center of the Switch Boards.
4. Obtain a high resistance and high wattage resistor (25-1000 ohms and 25 watts minimum). This resistor is not supplied with machine. NEVER USE A SHORTING STRAP FOR THIS PROCEDURE.
5. Locate the two capacitor terminals (large hex head capscrews) shown in Figure F.1.
6. Use electrically insulated gloves and insulated pliers. Hold body of the resistor and connect resistor leads across the two capacitor terminals. Hold resistor in place for 10 seconds. DO NOT TOUCH CAPACITOR TERMINALS WITH YOUR BARE HANDS.
7. Repeat discharge procedure for capacitor on other side of machine. If you are working on a 575 VAC machine, repeat discharge procedure for second capacitor on each side of machine.
8. Check voltage across terminals of all capacitors with a DC voltmeter. Polarity of capacitor terminals is marked on PC board above terminals. Voltage should be zero. If any voltage remains, repeat this capacitor discharge procedure.

FIGURE F.I - LOCATION OF INPUT FILTER CAPACITOR TERMINALS

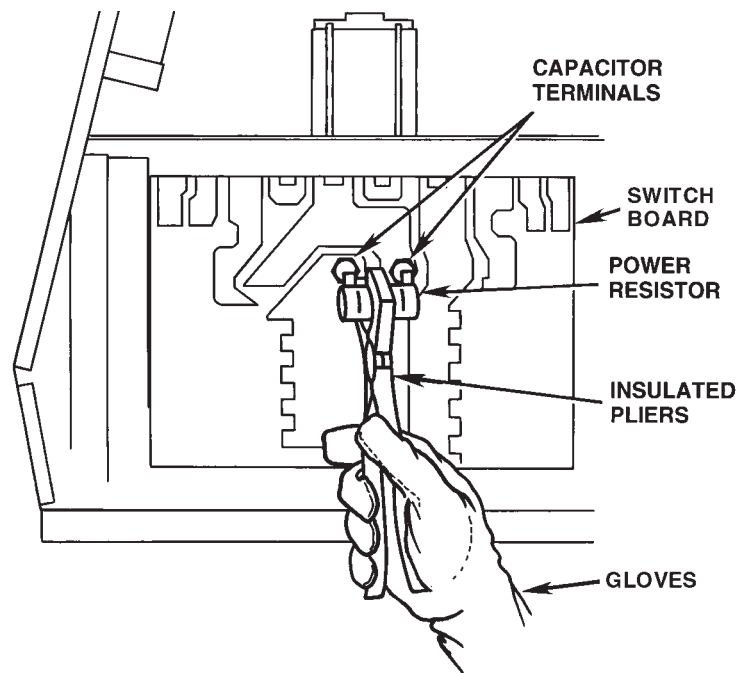

V300-PRO

LINCOLN
ELECTRIC

OUTPUT PILOT CIRCUIT TEST



WARNING

Service and repair should be performed by only Lincoln Electric factory trained personnel. Unauthorized repairs performed on this equipment may result in danger to the technician or machine operator and will invalidate your factory warranty. For your safety and to avoid electrical shock, please observe all safety notes and precautions detailed throughout this manual.

If for any reason you do not understand the test procedures or are unable to perform the test / repairs safely, contact the Lincoln Electric Service Department for electrical troubleshooting assistance before you proceed. Call 1-888-935-3877.

TEST DESCRIPTION

This procedure will determine if the Thermostats, the Auxiliary Transformer (T1) and the Output Terminal Switch (S4) are functioning properly.

MATERIALS NEEDED

- Volt/Ohm Meter (multi-meter)
- Misc. Hand Tools
- Wiring Diagram (Section G)

Return to Section TOC
Return to Master TOC

Return to Section TOC
Return to Master TOC

Return to Section TOC
Return to Master TOC

Return to Section TOC
Return to Master TOC

V300-PRO



OUTPUT PILOT CIRCUIT TEST(cont.)

TEST PROCEDURE

1. Turn Input Power Switch OFF
2. Perform **Input Capacitor Discharge** test as described in the Maintenance Section.
3. Remove the four screws that hold the Control Panel to the frame.
4. Move the Control Panel forward and to the left so that there is access to the Control PC Board. Be careful not to stress any of the connections to the Control Panel.
5. Set the Output Terminals Switch to the ON position.
6. Turn the Input Power Switch ON.

FIGURE F.2 - REMOVING CONTROL PANEL

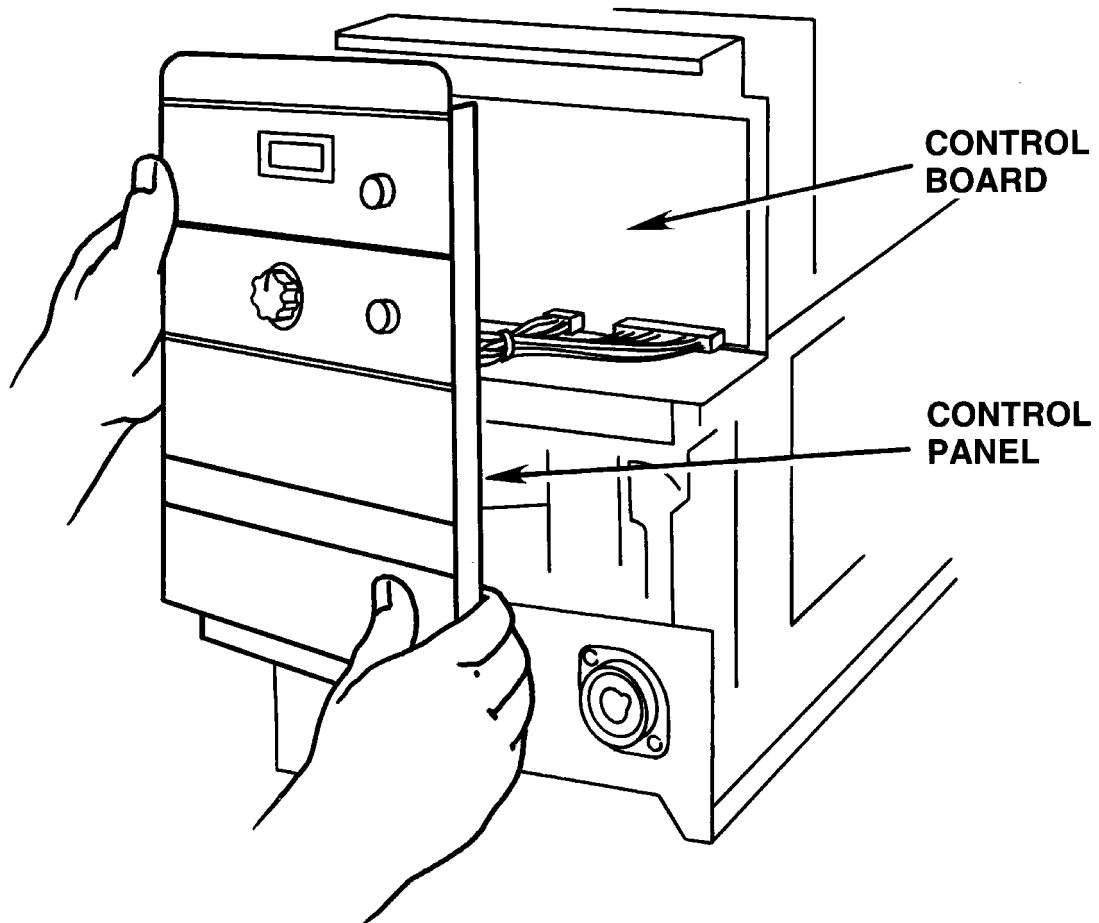

V300-PRO

LINCOLN
ELECTRIC

OUTPUT PILOT CIRCUIT TEST (cont.)

FIGURE F.3 – CONTROL BOARD TEST POINTS

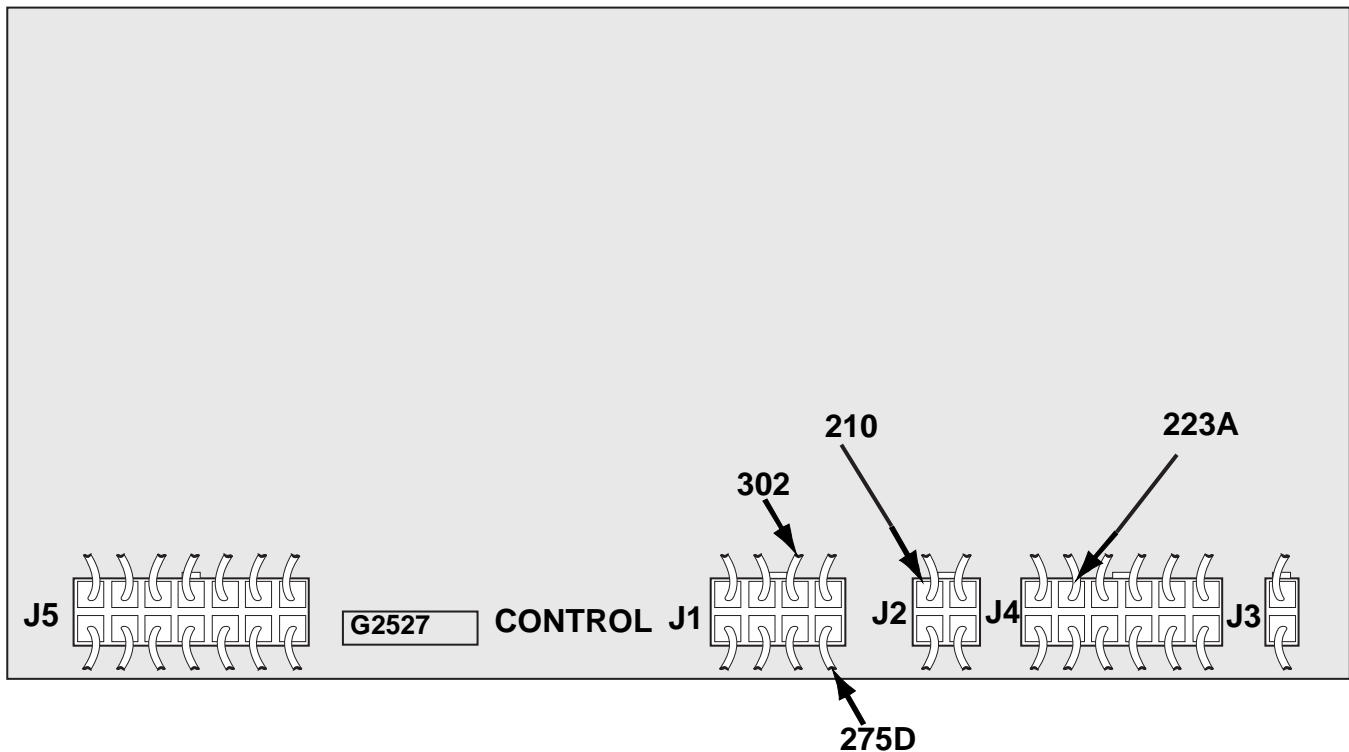

7. Measure voltage from Lead #210 (J2/Pin 4) to Lead # 223A (J4/Pin 11).

- a. If voltage is 24v.a.c., thermostats, transformer T1 and switch (S4) are OK. Go on to Step 8.
- b. If voltage is 0v.a.c. test the following components individually:
 - Auxiliary Transformer T1
 - Fan Thermostat
 - Choke Thermostat
 - Output Terminal Switch (S4)

8. Measure voltage from lead 302 (J1/Pin 6) to Lead 275D (J1 /Pin1).

- a. If voltage is 15v.d.c, Transformer T1 and 15 volt supply are OK. Go to **Protection Board Output** test.
- b. If voltage is 0v.d.c. check Transformer T1 and then go to **Power Board** test

Return to Section TOC Return to Section TOC Return to Section TOC
Return to Master TOC Return to Master TOC Return to Master TOC

V300-PRO



PROTECTION BOARD OUTPUT TEST



WARNING

Service and repair should be performed by only Lincoln Electric factory trained personnel. Unauthorized repairs performed on this equipment may result in danger to the technician or machine operator and will invalidate your factory warranty. For your safety and to avoid electrical shock, please observe all safety notes and precautions detailed throughout this manual.

If for any reason you do not understand the test procedures or are unable to perform the test / repairs safely, contact the Lincoln Electric Service Department for electrical troubleshooting assistance before you proceed. Call 1-888-935-3877.

TEST DESCRIPTION

This procedure will determine if the Protection PC Board is defective , or responding to external signals causing it to prevent the Input Filter Capacitors from charging.

MATERIALS NEEDED

Volt/Ohm Meter (multi-meter)

Misc Hand Tools

Wiring Diagram (Section G)

Return to Section TOC
Return to Master TOC

Return to Section TOC
Return to Master TOC

Return to Section TOC
Return to Master TOC

Return to Section TOC
Return to Master TOC

V300-PRO



PROTECTION BOARD OUTPUT TEST(cont.)

TEST PROCEDURE

1. TURN POWER SWITCH OFF
2. Remove sheetmetal wraparound.
3. Perform Input Filter Capacitor Discharge procedure detailed in Maintenance section
4. Remove the two through bolts that attach the Power/Driver Board bracket to Protection/Input Rectifier bracket. Each through bolt also supports a resistor.
5. Slide the through bolts toward the Control Panel until the brackets are disconnected and resistors are loose. Be careful when loosening these through bolts, as they secure the two resistors. As the through bolts are removed, carefully place the resistors and the connected wires to the side

FIGURE F.4 — REMOVING THROUGH BOLTS & MOUNTING SCREWS

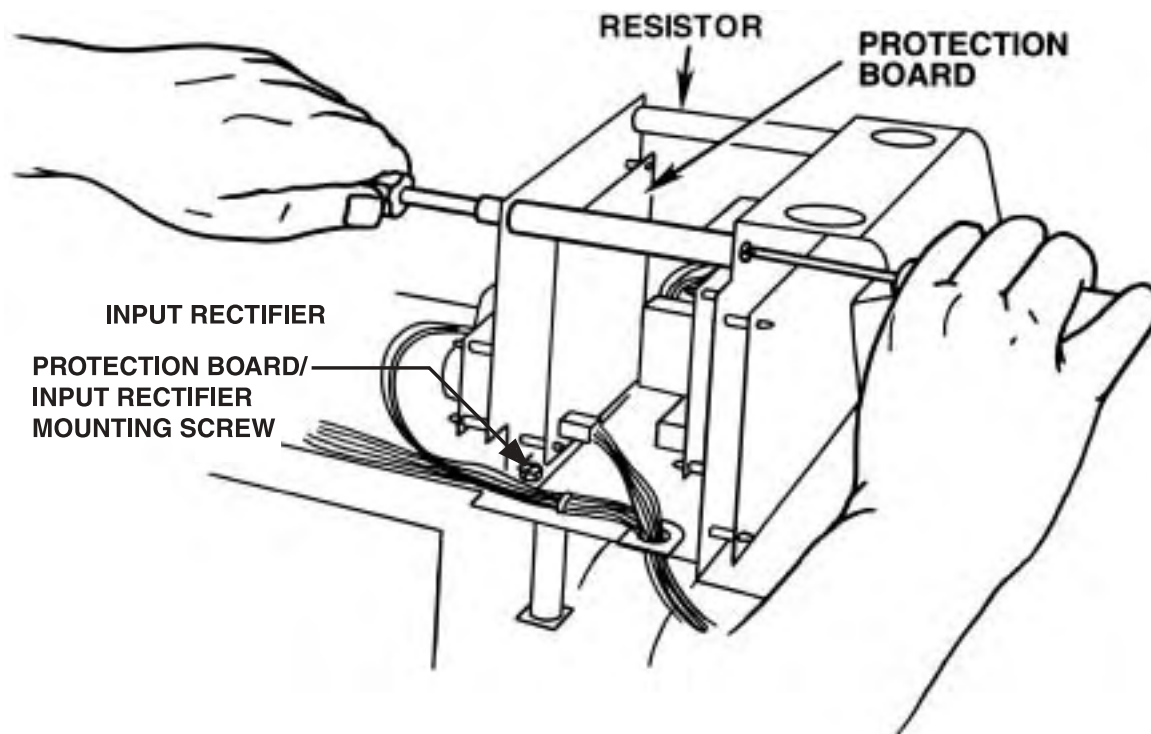

6. Remove the two screws attaching the Protection Board/ Input Rectifier bracket to main assembly bracket.
7. Tilt the top of the Protection Board bracket toward the Power Panel to gain access to test points on the Protection Board.

PROTECTION BOARD OUTPUT TEST(cont.)

TEST PROCEDURE

8. With power OFF, disconnect J8 and attach voltage probes into back of wire harness lead junction block (J8). See Figure F.5.

Insert probes into back of the connection cavities for leads 313 (-) and 311 (+) of Protection Board. Make sure contact is made with conductor material.

NOTE: Right-angle, thin-gauge probes are best for this test.

With probes attached, plug the (J8) block into the PC board.

9. Turn main power ON.
10. Move Output Terminal Switch S4 to ON position on Control Panel.
11. Test for less than 1 VDC between leads 313 (-) and 311 (+).
- If less than 1 VDC is measured, test is OK and Protection Board is functioning properly.
 - If more than 5 VDC is measured, go to Static Capacitor Balance Test.

NOTE:. During voltage test, be cautious when positioning loose components to avoid shorts and damage to equipment.

FIGURE F.5 - INSERTING PROBES

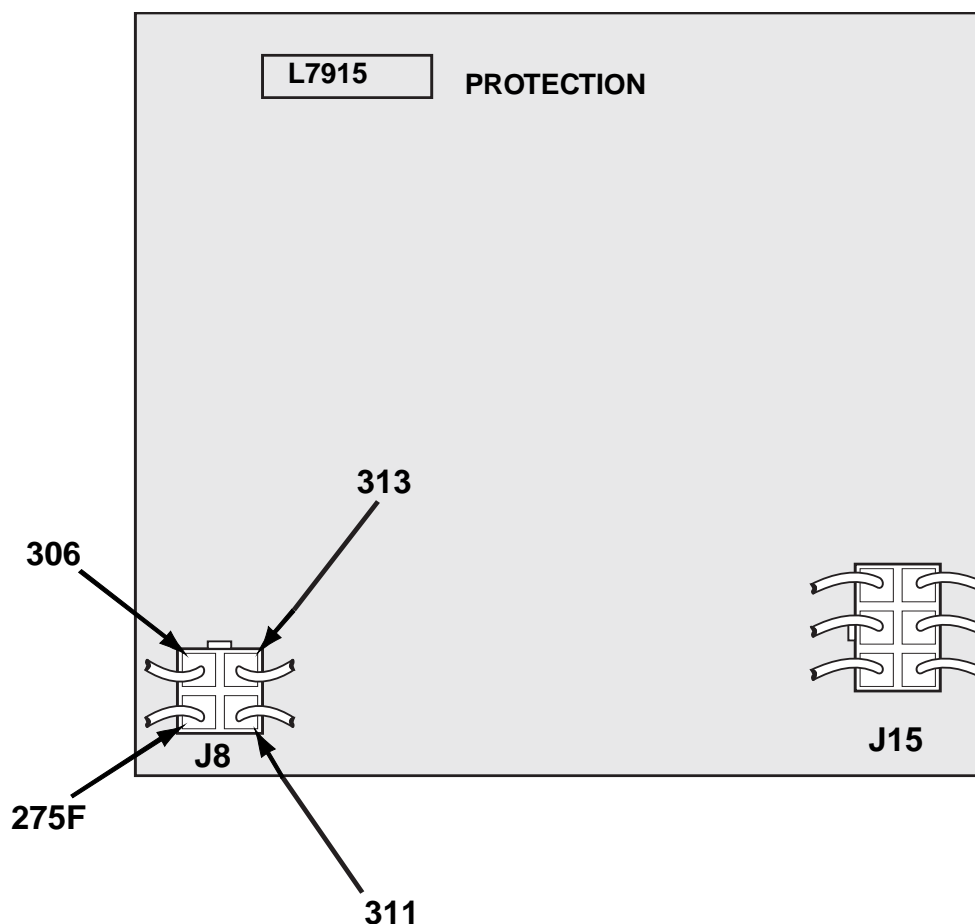

V300-PRO

LINCOLN
ELECTRIC

PROTECTION BOARD OUTPUT TEST(cont.)

FIGURE F.6 - INSERTING PROBES

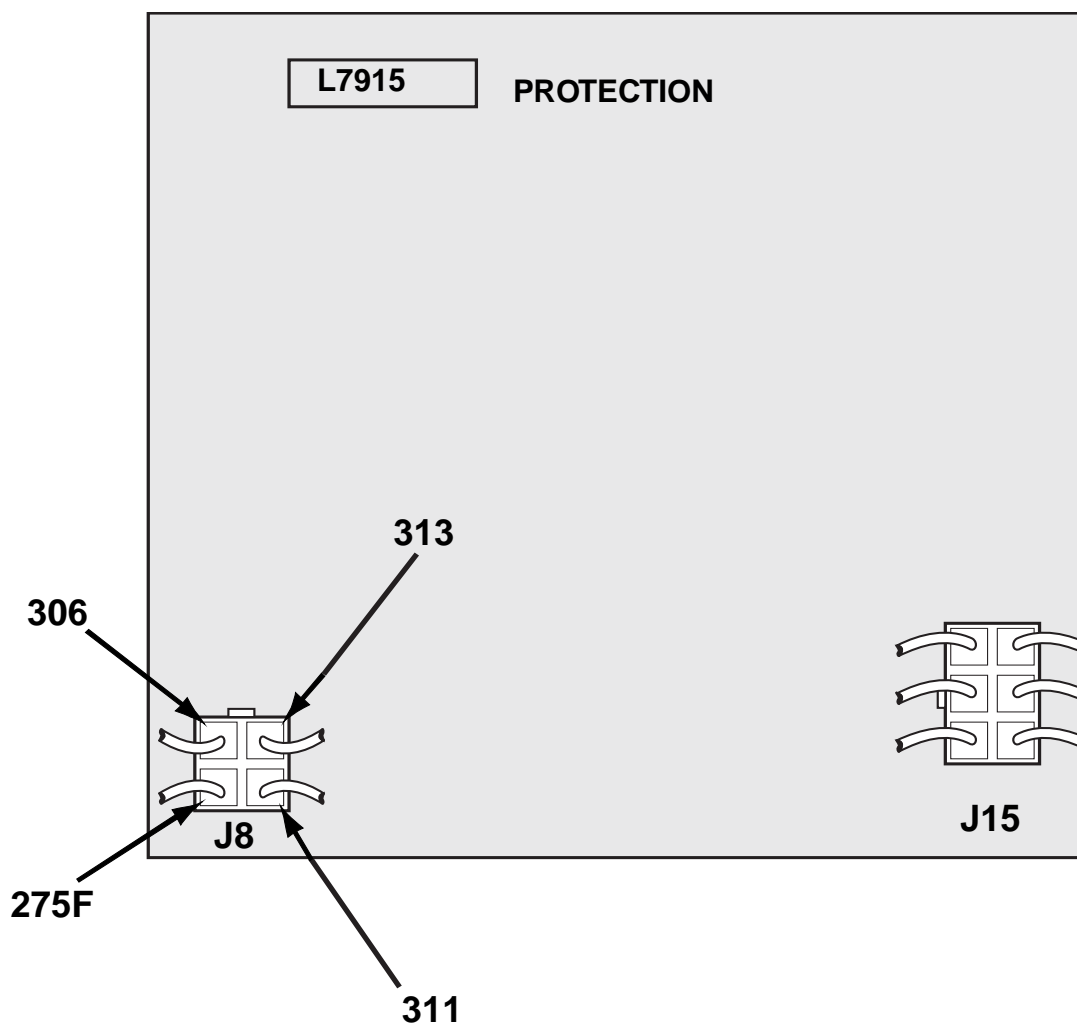

TEST PROCEDURE

12. Open S4 and Turn Power OFF
13. Move probes to test between leads 306 (+) and 275 (-). (See Figure F.6)
14. Turn Power ON and close S4. If voltage is less than 1 VDC, Protection Board is OK. If voltage is greater than 14 VDC, Protection Board may be defective. See **Overvoltage Protection DC Trigger Circuit** test, Step 11.

CAPACITOR BALANCE TEST

**WARNING**

Service and repair should be performed by only Lincoln Electric factory trained personnel. Unauthorized repairs performed on this equipment may result in danger to the technician or machine operator and will invalidate your factory warranty. For your safety and to avoid electrical shock, please observe all safety notes and precautions detailed throughout this manual.

If for any reason you do not understand the test procedures or are unable to perform the test / repairs safely, contact the Lincoln Electric Service Department for electrical troubleshooting assistance before you proceed. Call 1-888-935-3877.

TEST DESCRIPTION

This procedure will determine the condition of the capacitors, bleeder resistors and Switch Boards.

MATERIALS NEEDED

Volt/Ohm Meter (multi-meter)

Misc. Hand Tools

Wiring Diagram (Section G)

NOTE: This procedure should only be done with the reconnect switches and jumper set for “380-460” Volt operation and the proper input voltage applied.

V300-PRO

CAPACITOR BALANCE TEST (cont.)

STATIC CAPACITOR TEST

TEST PROCEDURE:

1. With Output Terminal Switch S4 in REMOTE (OFF) position, turn Power Switch ON.
2. Test VDC across terminals 9 and 12 of one Switch Board (*see Fig F.7*). Repeat the test for the other Switch Board. See Table F.1 in this procedure for expected voltage readings.

NOTE: For 575 VAC only machines, compare voltage across 9A and 13 and 13 and 12A; then 9B and 15 and 15 and 12B.

3. Record VDC measured for each Switch Board and determine the difference in VDC.

NOTE: The following measurements should result based on VAC input.

TABLE F.1 — EXPECTED VOLTAGE READINGS.

If VAC Input is:	VDC at Switch Board Terminals should be approximately:
575VAC	407 VDC
460 VAC	325 VDC
440 VAC	311 VDC
415 VAC	293 VDC
380 VAC	269 VDC

- a. If less than 25 VDC difference is measured between the Switch Boards, then capacitor balance is OK.
 - This indicates that Capacitors C1 and C2, Resistors R1 and R9 are OK.
 - (575 VAC only machines — Capacitors C1, C2, C14, and C15; Resistors R1 and R9 are OK.)

Go to Dynamic Capacitor Balance Test.

- b. If more than 25 VDC difference is measured between the Switch Boards, test each of the following components:

- Capacitors C1 and C2 and Resistors R1 and R9.
- (575 VAC only machines —Capacitors C1, C2, C14, and C15; and Resistors R1 and R9.)

DYNAMIC CAPACITOR TEST

TEST PROCEDURE:

1. Move Output Terminal Switch S4 to ON position.

Adjust the output control to the minimum setting. Place the mode control at the SMAW (soft) position.

2. Test VDC across terminals 9 and 12 of one Switch Board (*see Fig. F.7*). Repeat the test for the other Switch Board. See Table F.1 for expected voltages

NOTE: For 575 VAC ONLY, compare voltage across 9A and 13 and 13 and 12A; then 9B and 15 and 15 and 12B.

3. Record VDC measured for each Switch Board and determine the difference in VDC. (See Table F1).

- a. If less than 15 VDC difference is measured between the Switch Boards, test is OK.
- b. If more than 15 VDC difference is measured between the Switch Boards, the Power Board or Switch Board is damaged. See **SWITCH BOARD** test and **POWER BOARD** test.

CAPACITOR BALANCE TEST (cont.)

FIGURE F.7 - SWITCH BOARD TEST POINTS

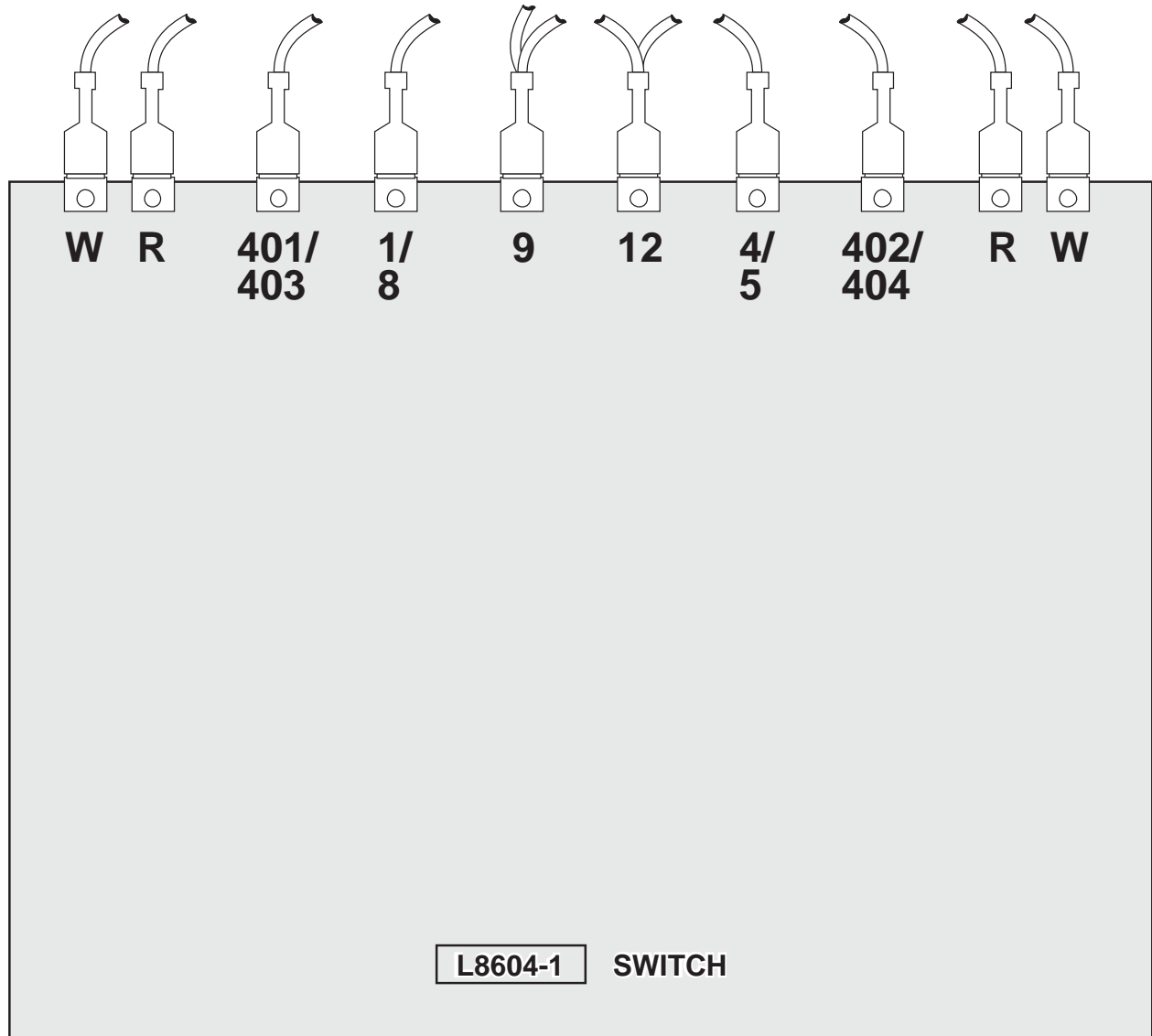

Return to Section TOC
Return to Master TOC
Return to Section TOC
Return to Master TOC
Return to Section TOC
Return to Master TOC
Return to Section TOC
Return to Master TOC

Return to Section TOC
Return to Master TOC
Return to Section TOC
Return to Master TOC
Return to Section TOC
Return to Master TOC
Return to Section TOC
Return to Master TOC

V300-PRO



SWITCH BOARD TEST

**WARNING**

Service and repair should be performed by only Lincoln Electric factory trained personnel. Unauthorized repairs performed on this equipment may result in danger to the technician or machine operator and will invalidate your factory warranty. For your safety and to avoid electrical shock, please observe all safety notes and precautions detailed throughout this manual.

If for any reason you do not understand the test procedures or are unable to perform the test / repairs safely, contact the Lincoln Electric Service Department for electrical troubleshooting assistance before you proceed. Call 1-888-935-3877.

TEST DESCRIPTION

This procedure will determine if the Switch Boards are working properly. This resistance test is preferable to a voltage test with the machine energized because these boards are easily damaged. Also, it is more dangerous to work on these boards when power is applied.

MATERIALS NEEDED

ANALOG Volt/Ohm Meter (multi-meter)

Misc. Hand Tools

Wiring Diagram (Section G)

NOTE: Most digital meters will not supply enough current in the “ohms” mode to do this test effectively.

V300-PRO



SWITCH BOARD TEST (cont.)

TEST PROCEDURE

1. Disconnect power to the machine and perform **Input Filter Capacitor Discharge Procedure** as described in Section F.
2. Disconnect all wiring harness leads (401/403, 1/8, 9, 12, 4/5, 402/404) from the Switch Boards.
3. Fold the leads up so they do not interfere with the exposed PC board terminals. See Figure F.8.
4. Using an ohmmeter, perform the Resistance Tests detailed in **Table F.2** and **Table F.3**. If any test fails, replace both Switch Boards. **See Switch Board replacement procedure.**
5. If the Switch Boards appear to be burned or overheated, or if the machine was supplied by a 380 VAC or higher voltage supply when the failure occurred, replace the Capacitors and the Switch Boards.

FIGURE F.8 - SWITCH BOARD RESISTANCE TEST

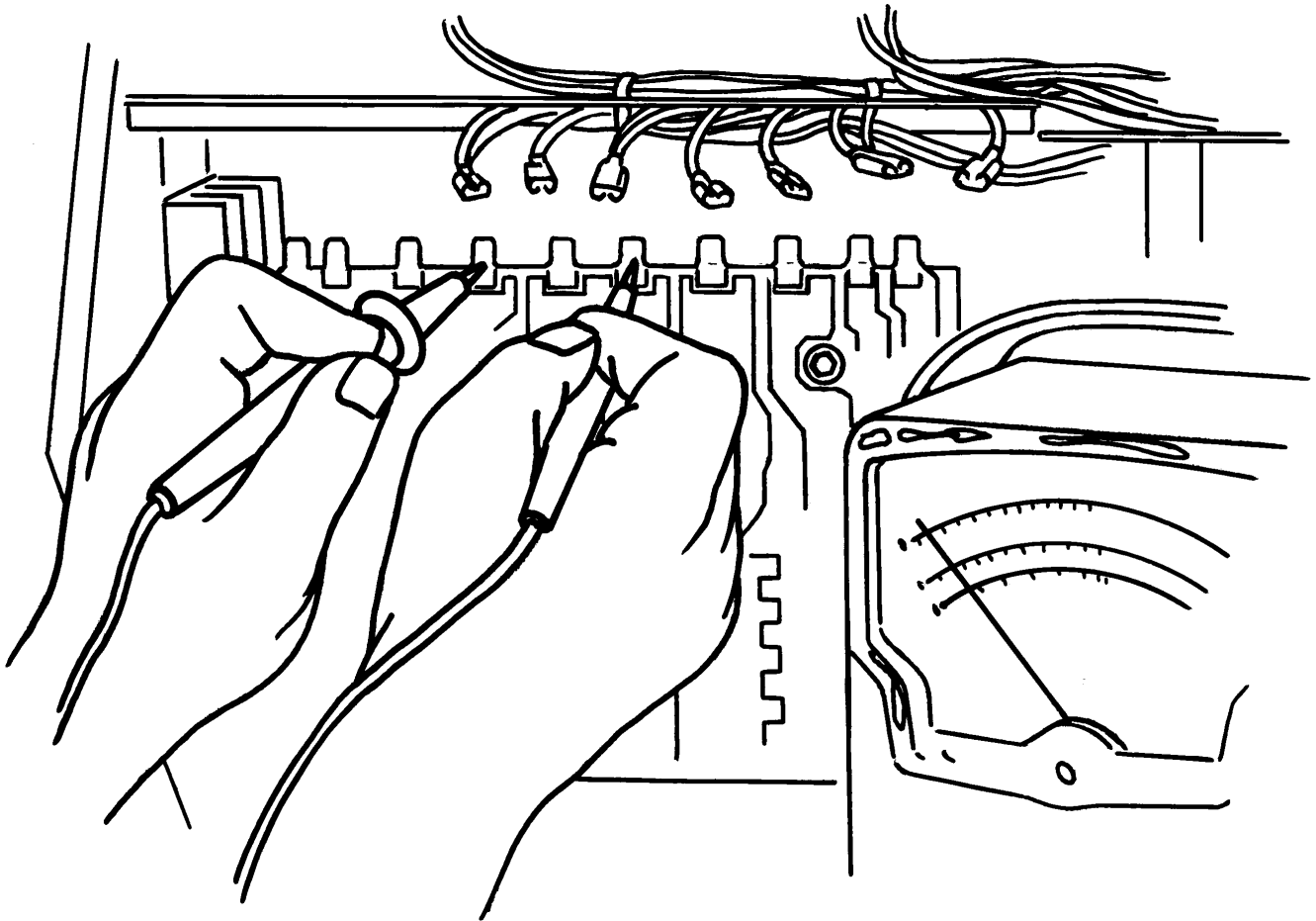

SWITCH BOARD TEST (CONT.)

TABLE F.2
SWITCH BOARD RESISTANCE CHECKS

Apply Positive Test Probe to Terminal	Apply Negative Test Probe to Terminal	Test Result	Conclusion	Repair Action	Next Procedure	Notes
1/8	12	Greater than 1K ohm	OK	None	Continue	
		Less than 100 ohms	Shorted	Replace both Switch Boards	Snubber Test	
12	1/8	Less than 100 ohms	OK	None	Continue	
		Greater than 1K ohm	Open	Replace both Switch Boards	Snubber Test	
9	4/5	Greater than 1K ohm	OK	None	Continue	
		Less than 100 ohms	Shorted	Replace both Switch Boards	Snubber Test	
4/5	9	Less than 100 ohms	OK	None	Continue	
		Greater than 1K ohm	Open	Replace both Switch Boards	Snubber Test	
1/8	9	Less than 100 ohms	OK	None	Continue	
		Greater than 1K ohm	Open	Replace both Switch Boards	Snubber Test	
9	1/8	Greater than 1K ohm	OK	None	Continue	
		Less than 100 ohms	Shorted	Replace both Switch Boards	Snubber Test	
12	4/5	Less than 100 ohms	OK	None	Continue	
		Greater than 1K ohm	Open	Replace both Switch Boards	Snubber Test	
4/5	12	Greater than 1K ohm	OK	None	Continue	
		Less than 100 ohms	Shorted	Replace both Switch Boards	Snubber Test	

NOTE: K ohm = ohm reading multiplied by 1000.

NOTE: Always make sure that Switch Boards are changed in matched pairs. Never mix an old style (different part number) Switch Board with a newer style.

V300-PRO



SWITCH BOARD TEST (CONT.)

**TABLE F.3
SWITCH BOARD RESISTANCE CHECKS**

Apply Positive Test Probe to Terminal	Apply Negative Test Probe to Terminal	Test Result	Conclusion	Repair Action	Next Procedure	Notes
12	401/403	Greater than 1K ohm	OK	None	Continue	
		Less than 100 ohms	Shorted	Replace both Switch Boards	Snubber Test	
401/403	12	Less than 100 ohms	OK	None	Continue	
		Greater than 1K ohm	Open	Replace both Switch Boards	Snubber Test	
9	402/404	Less than 100 ohms	OK	None	Continue	
		Greater than 1K ohm	Open	Replace both Switch Boards	Snubber Test	
402/404	9	Greater than 1K ohm	OK	None	Continue	
		Less than 100 ohms	Shorted	Replace both Switch Boards	Snubber Test	

V300-PRO



Return to Section TOC

Return to Section TOC

Return to Section TOC

Return to Section TOC

Return to Master TOC

Return to Master TOC

Return to Master TOC

Return to Master TOC

SNUBBER RESISTOR TEST**WARNING**

Service and repair should be performed by only Lincoln Electric factory trained personnel. Unauthorized repairs performed on this equipment may result in danger to the technician or machine operator and will invalidate your factory warranty. For your safety and to avoid electrical shock, please observe all safety notes and precautions detailed throughout this manual.

If for any reason you do not understand the test procedures or are unable to perform the test / repairs safely, contact the Lincoln Electric Service Department for electrical troubleshooting assistance before you proceed. Call 1-888-935-3877.

TEST DESCRIPTION

This procedure will determine if the Snubber Resistors are defective.

MATERIALS NEEDED

- Volt/Ohm Meter (multi-meter)
- Misc. Hand Tools
- Wiring Diagram (Section G)

Return to Section TOC
Return to Master TOC

Return to Section TOC
Return to Master TOC

Return to Section TOC
Return to Master TOC

Return to Section TOC
Return to Master TOC

V300-PRO

OUTPUT DIODE TEST



WARNING

Service and repair should be performed by only Lincoln Electric factory trained personnel. Unauthorized repairs performed on this equipment may result in danger to the technician or machine operator and will invalidate your factory warranty. For your safety and to avoid electrical shock, please observe all safety notes and precautions detailed throughout this manual.

If for any reason you do not understand the test procedures or are unable to perform the test / repairs safely, contact the Lincoln Electric Service Department for electrical troubleshooting assistance before you proceed. Call 1-888-935-3877.

TEST DESCRIPTION

This procedure will determine if the Output Diodes are defective.

MATERIALS NEEDED

Volt/Ohm Meter (multi-meter)

Wiring Diagram (Section G)

V300-PRO



OUTPUT DIODE TEST (cont.)

TEST PROCEDURE

1. Locate the Output Terminals on front panel.
2. Remove any cables from Output Terminals.
3. Test for more than 200 ohms resistance between positive and negative Output Terminals: positive meter lead to the positive terminal, negative meter lead to the negative terminal.

NOTE: Polarity of test leads is important.

- a. If reading is more than 200 ohms, Output Diodes are OK.

- b. If reading is less than 100 ohms, one or more Output Diode is shorted. Test all Output Diodes (D-1 thru D-12) or diode modules individually.

NOTE: On codes prior to 10200 the diodes should also be tested individually to check for "Open" diodes. An open diode may cause an imbalance condition when output is activated. Be sure to perform the **Input Filter Capacitor Discharge Procedure** as detailed in this section.

FIGURE F.10 — TESTING OUTPUT DIODES.

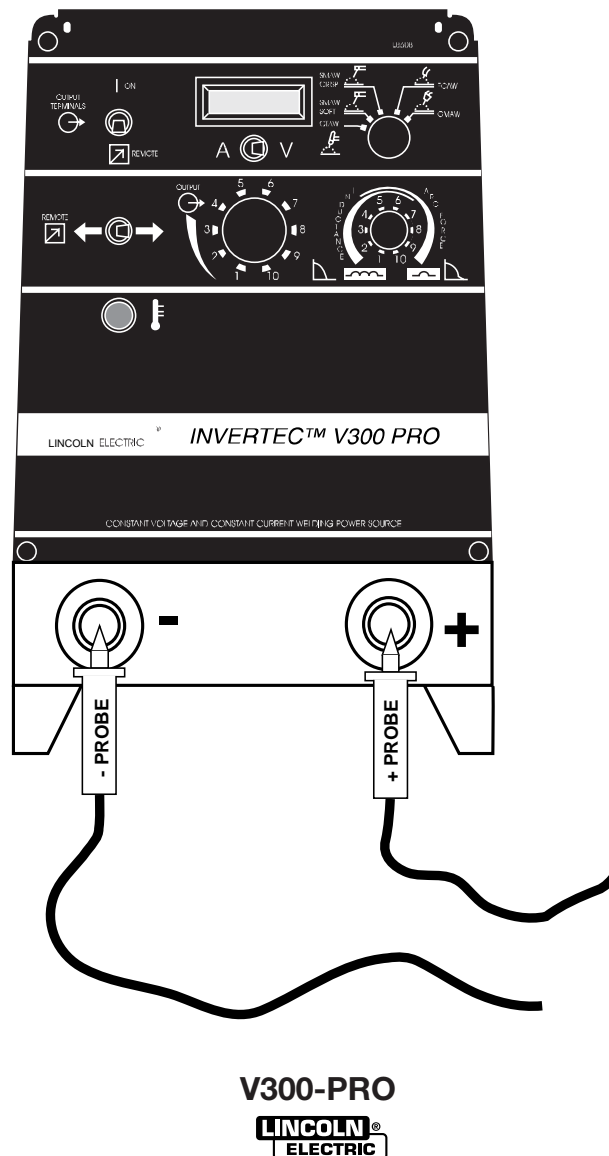

INPUT RECTIFIER TEST

**WARNING**

Service and repair should be performed by only Lincoln Electric factory trained personnel. Unauthorized repairs performed on this equipment may result in danger to the technician or machine operator and will invalidate your factory warranty. For your safety and to avoid electrical shock, please observe all safety notes and precautions detailed throughout this manual.

If for any reason you do not understand the test procedures or are unable to perform the test / repairs safely, contact the Lincoln Electric Service Department for electrical troubleshooting assistance before you proceed. Call 1-888-935-3877.

TEST DESCRIPTION

This procedure will determine if the Input Rectifier is defective.

MATERIALS NEEDED

ANALOG Volt/Ohm Meter (multi-meter)

Misc. Hand Tools

Wiring Diagram (Section G)

V300-PRO

INPUT RECTIFIER TEST

FIGURE F.11 - INPUT RECTIFIER LOCATION

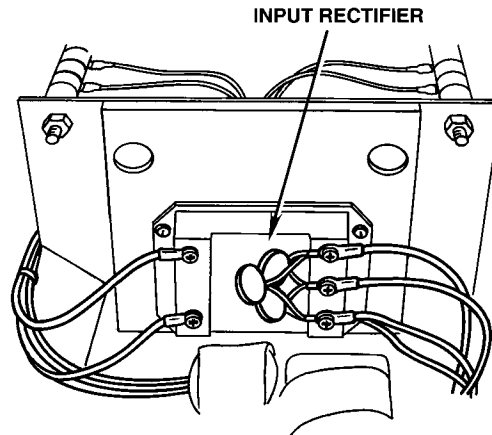

TEST PROCEDURE

1. Perform **Input Filter Capacitor Discharge Procedure** as detailed in this section.
2. Locate Input Rectifier (Component D-13).
3. Locate leads needed to perform tests shown in Figure F.11.
4. Use ohmmeter to perform tests shown in Table F.5. Replace the Input Rectifier if readings are not as indicated.
5. Inspect Main Power Switch S1 and replace if faulty. Go to step 7.
6. Test Capacitors C1 and C2 and replace both Capacitors if either is faulty.

NOTE: Faulty Capacitors could be the reason for a defective Input Rectifier.

Visually inspect Capacitors for leakage, damage, etc., and use appropriate test equipment to determine component integrity (also check/test Switch Boards for damage).

NOTE: When installing a new Input Rectifier, torque mounting nuts (in a cross tightening pattern) to 6 inch-pounds (.7 Nm). Torque terminals to 26 inch-pounds (3 Nm). ALWAYS GO TO STEP 6 TO CHECK RELATED COMPONENTS.

TABLE F.5

Steps	Test Points		Acceptable Meter Reading
	+ Probe	- Probe	
A	9	H1	Greater than 1K ohms
B	9	A	Greater than 1K ohms
C	9	H5	Greater than 1K ohms
D	H1	9	Less than 100 ohms
E	A	9	Less than 100 ohms
F	H5	9	Less than 100 ohms
G	12	H1	Less than 100 ohms
H	12	A	Less than 100 ohms
I	12	H5	Less than 100 ohms
J	H1	12	Greater than 1K ohms
K	A	12	Greater than 1K ohms
L	H5	12	Greater than 1K ohms

V300-PRO



Return to Section TOC

Return to Master TOC

OVERCURRENT PROTECTION CURRENT TRIGGER TEST**WARNING**

Service and repair should be performed by only Lincoln Electric factory trained personnel. Unauthorized repairs performed on this equipment may result in danger to the technician or machine operator and will invalidate your factory warranty. For your safety and to avoid electrical shock, please observe all safety notes and precautions detailed throughout this manual.

If for any reason you do not understand the test procedures or are unable to perform the test / repairs safely, contact the Lincoln Electric Service Department for electrical troubleshooting assistance before you proceed. Call 1-888-935-3877.

TEST DESCRIPTION

This procedure will determine if the overcurrent trigger circuit is working correctly and also if the current limiting portion of the Control Board is working correctly.

MATERIALS NEEDED

- Digital Volt/Ohm Meter (multi-meter)
- Misc. Hand Tools
- Wiring Diagram (Section G)

V300-PRO

OVERCURRENT PROTECTION CURRENT TRIGGER TEST (cont.)

FIGURE F.14 - CONTROL BOARD TEST POINTS

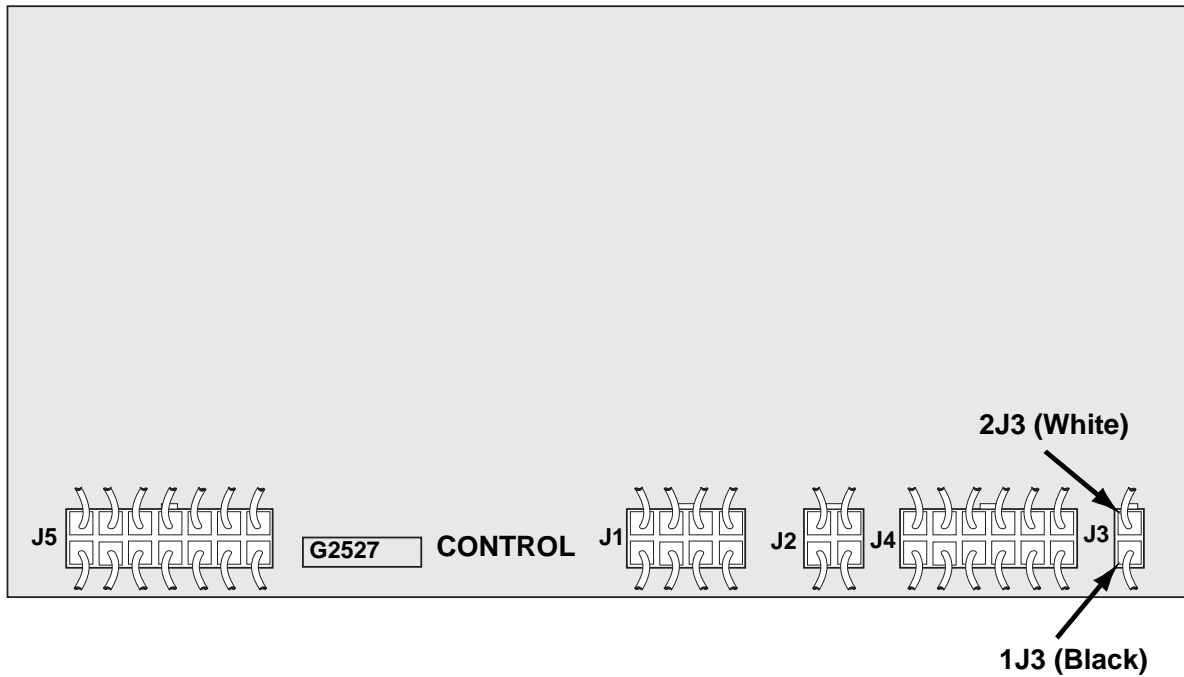

6. Turn main power OFF.

7. Perform **Input Filter Capacitor Discharge Procedure** detailed in this section.

Test resistance of the Black and White leads from 1J3 and 2J3 to the shunt. See Figure F.14.

NOTE: On earlier codes the terminals on the shunt leads were crimped but not soldered. Corrosion may cause inaccurate current readings. Cleaning and soldering the terminals to the leads may eliminate that problem.

- a. If zero ohms resistance (continuity) is shown, test is OK.
- b. If resistance of any value is shown, check wire and connections.

If tests for steps 5, 7, are OK and the machine continues to experience the problem, the Control Board should be replaced.

FIGURE F.15 - OVERCURRENT PROTECTION CURRENT TRIGGER CIRCUIT.

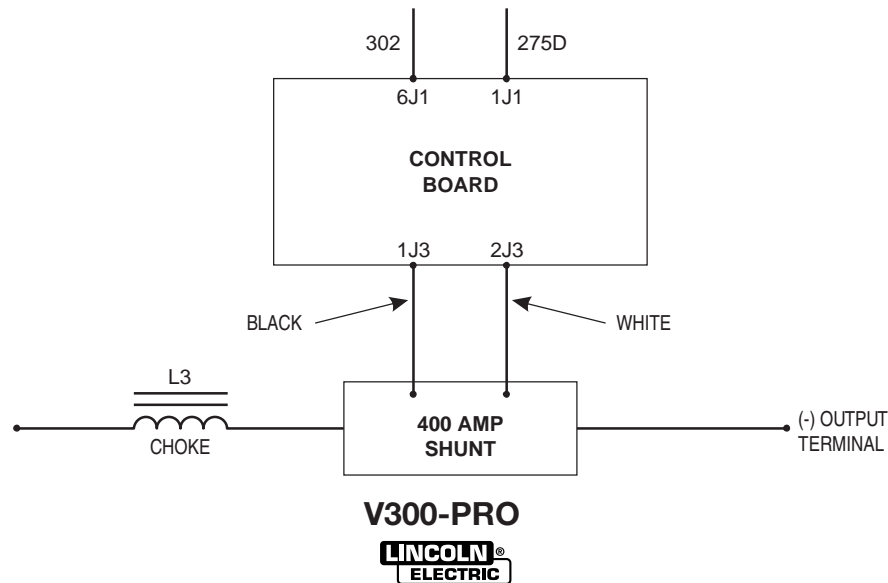

Return to Section TOC

Return to Section TOC

Return to Section TOC

Return to Section TOC

Return to Master TOC

Return to Master TOC

Return to Master TOC

Return to Master TOC

OVERVOLTAGE PROTECTION DC TRIGGER CIRCUIT TEST



WARNING

Service and repair should be performed by only Lincoln Electric factory trained personnel. Unauthorized repairs performed on this equipment may result in danger to the technician or machine operator and will invalidate your factory warranty. For your safety and to avoid electrical shock, please observe all safety notes and precautions detailed throughout this manual.

If for any reason you do not understand the test procedures or are unable to perform the test / repairs safely, contact the Lincoln Electric Service Department for electrical troubleshooting assistance before you proceed. Call 1-888-935-3877.

TEST DESCRIPTION

This procedure will determine if the overvoltage protection and related portions of the Protection Board and Power Board are functioning properly.

MATERIALS NEEDED

- Volt/Ohm Meter (multi-meter)
- Misc. Hand Tools
- Wiring Diagram (Section G)

NOTE: Fig. F.19 shows the Overvoltage Protection DC trigger Circuit.

OVERVOLTAGE PROTECTION DC TRIGGER CIRCUIT TEST (cont.)

FIGURE F.16 - PC BOARDS REMOVED

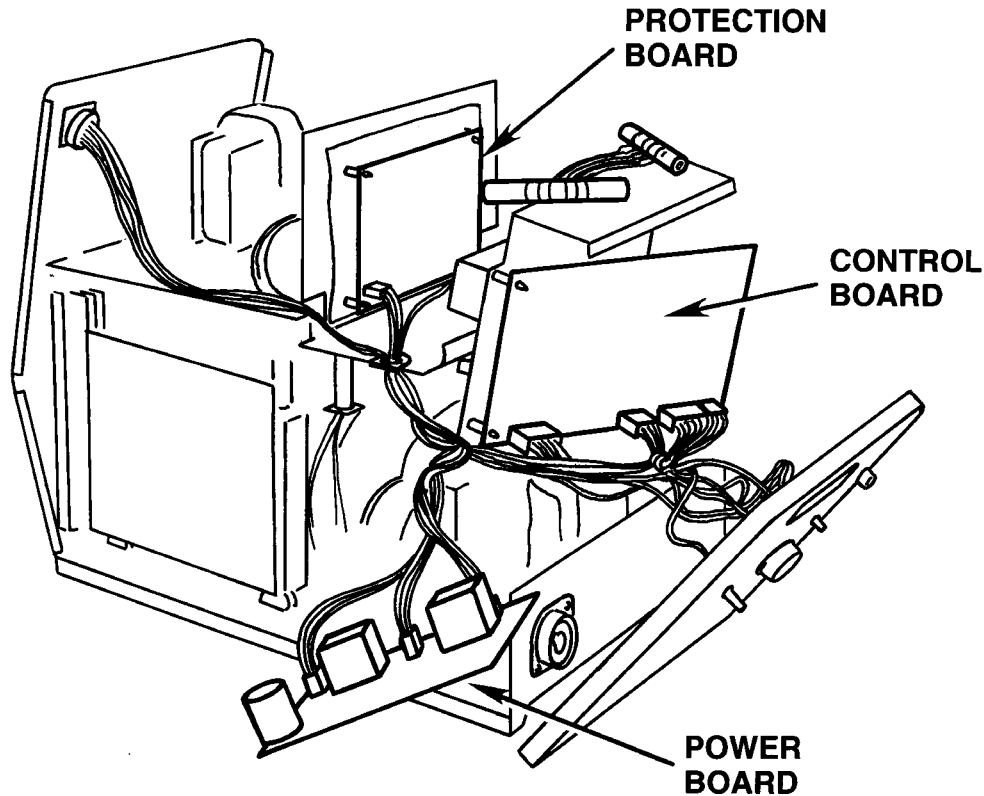

TEST PROCEDURE

1. Turn main power OFF.
2. Perform **Input Filter Capacitor Discharge** procedure detailed in Maintenance section.
3. Detach the following PC boards so you can gain access to and have ample room to perform the tests: (Do not disconnect from wiring harness.)

- Control Board
- Protection Board
- Power Board

NOTE: Do not disconnect any wires. The machine must be functional to perform tests.

4. Arrange the PC boards and wiring so you can easily perform the tests.

NOTE: Do not allow live connections to touch each other.

5. Turn main power ON.
6. Move the Output Terminal Switch S4 to the ON position (closed).

V300-PRO

LINCOLN
ELECTRIC

OVERVOLTAGE PROTECTION DC TRIGGER CIRCUIT TEST (cont.)

FIGURE F.17 — PROTECTION BOARD TEST POINT

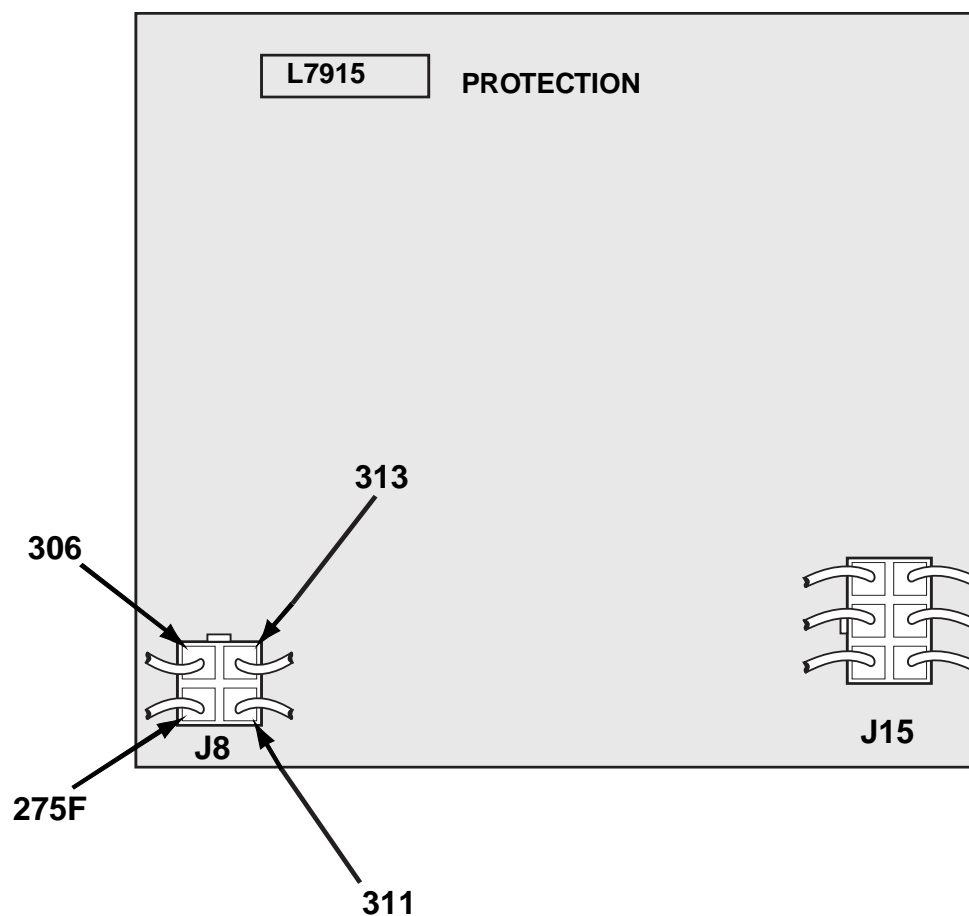

7. Test for 0 VDC between leads 311 and 313 on Protection Board.
 - a. If 0-1 VDC is present, the Protection Board is OK. Go to step 8.
 - b. If 15 VDC is present, go to step 11.

OVERVOLTAGE PROTECTION DC TRIGGER CIRCUIT TEST (cont.)

FIGURE F.18 - POWER BOARD TEST POINTS

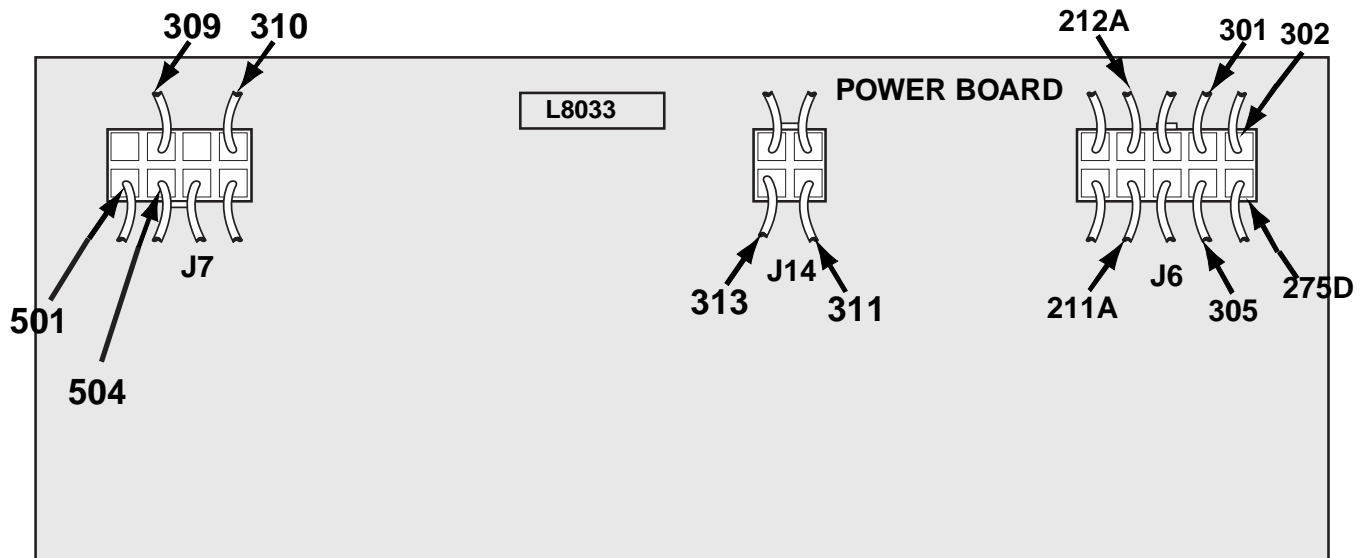

8. Test for 15 VDC supply voltage between leads 302 and 275D on Power Board.
 - a. If 15 VDC is present, test is OK. Go to step 9.
 - b. If 15 VDC is not present, the Power Board may be faulty. Check for 18 VAC input voltage at lead 501 and 504 (J7).

If 18 VAC is present the Power Board is faulty and must be replaced.
9. Test for 0-1 VDC (DC trigger circuit) between leads 305 and 275D on Power Board.
 - a. If 0-1 VDC is present, DC trigger circuit is operating properly.
 - b. If 15 VDC is present, go to step 10.
10. Test for 0-1 VDC between leads 301 and 275D on Power Board.
 - a. If 0-1 VDC is present, AC trigger, Control Board, and Power Board are operating properly.
 - b. If 15 VDC is present, go to Thermal Protection AC Trigger Circuit Test .

OVERVOLTAGE PROTECTION DC TRIGGER CIRCUIT TEST (cont.)

FIG. F.19 - OVERVOLTAGE PROTECTION DC TRIGGER CIRCUIT

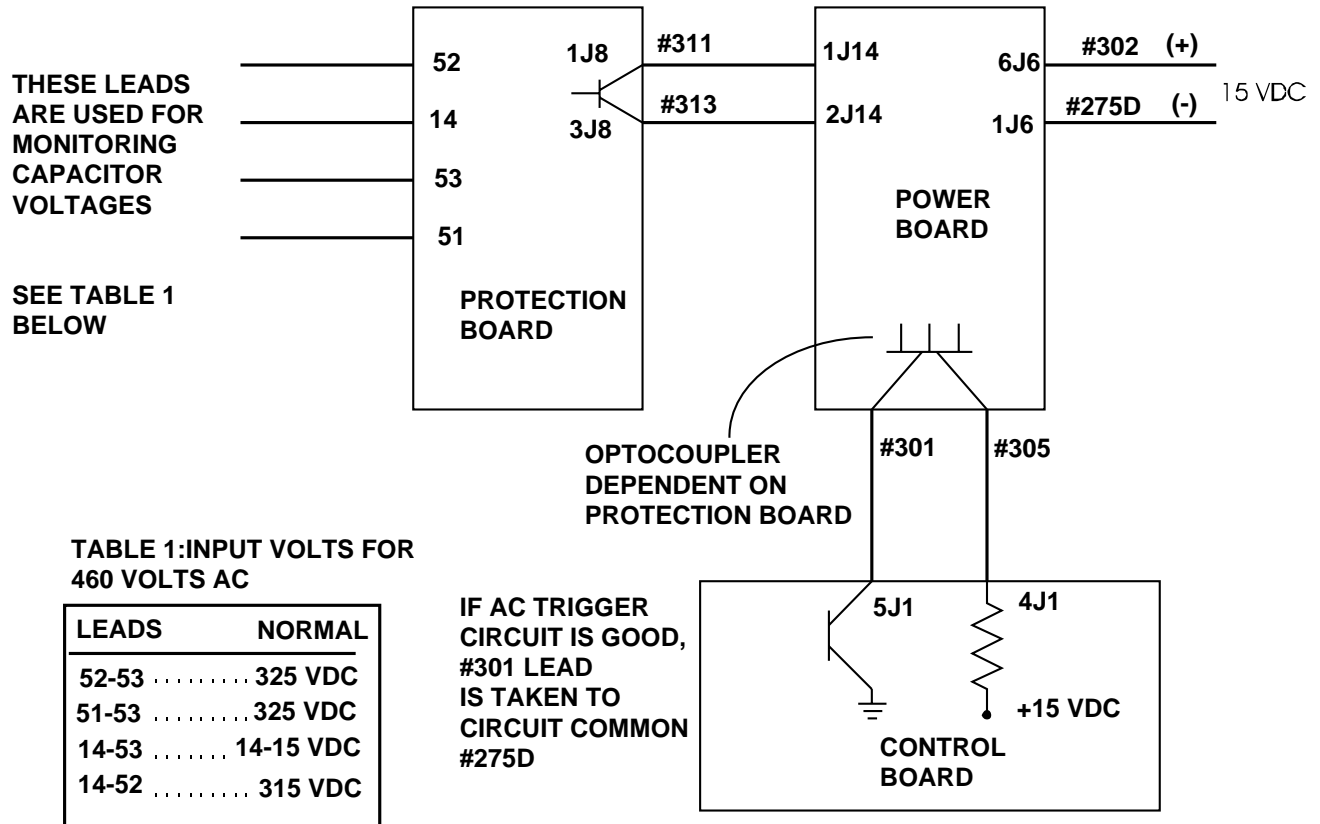

11. If 15 VDC is present at step 7, test Capacitor voltages using leads shown in Figure F.19.

If voltage does not match table, check reconnect switches for proper operation and proper position for voltage applied. Perform **Capacitor Balance Tests**.

Return to Section TOC
Return to Master TOC

THERMAL PROTECTION AC TRIGGER CIRCUIT



WARNING

Service and repair should be performed by only Lincoln Electric factory trained personnel. Unauthorized repairs performed on this equipment may result in danger to the technician or machine operator and will invalidate your factory warranty. For your safety and to avoid electrical shock, please observe all safety notes and precautions detailed throughout this manual.

If for any reason you do not understand the test procedures or are unable to perform the test / repairs safely, contact the Lincoln Electric Service Department for electrical troubleshooting assistance before you proceed. Call 1-888-935-3877.

TEST DESCRIPTION

This procedure will check the two thermostats and associated circuitry through the Auxiliary Transformer, Power Board and Control Board.

MATERIALS NEEDED

Volt/Ohm Meter (multi-meter)

Misc. Hand Tools

Wiring Diagram (Section G)

V300-PRO



THERMAL PROTECTION AC TRIGGER CIRCUIT (cont.)

FIGURE F.20 - PC BOARDS MOVED FOR ACCESS

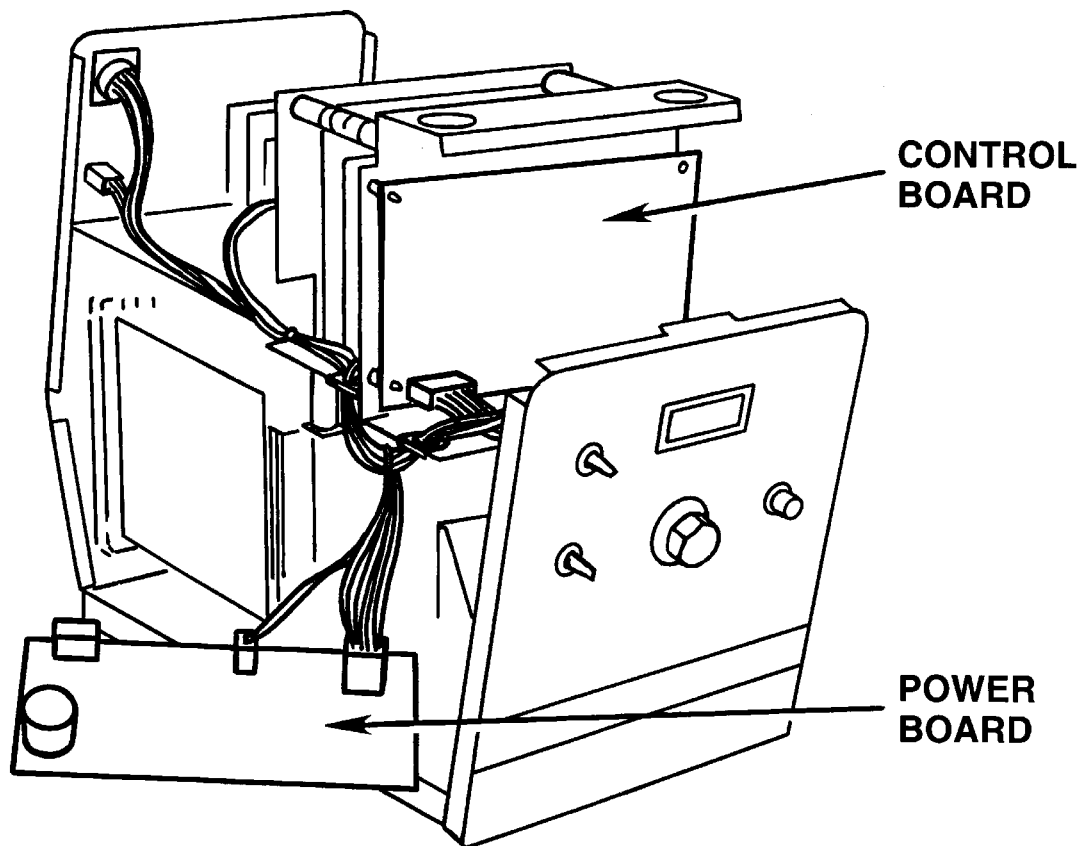

TEST PROCEDURE

1. Turn main power OFF.
2. Perform *Input Filter Capacitor Discharge procedure* detailed in this section.
3. Detach the following PC boards so you can gain access to and have ample room to perform the tests. (Do not disconnect from wiring harness.)
 - Power Board
 - Control Board

NOTE: Do not disconnect any wires. The machine must be functional to perform test.

V300-PRO

LINCOLN
ELECTRIC

THERMAL PROTECTION AC TRIGGER CIRCUIT (cont.)

FIGURE F.21 - THERMAL PROTECTION AC TRIGGER CIRCUIT

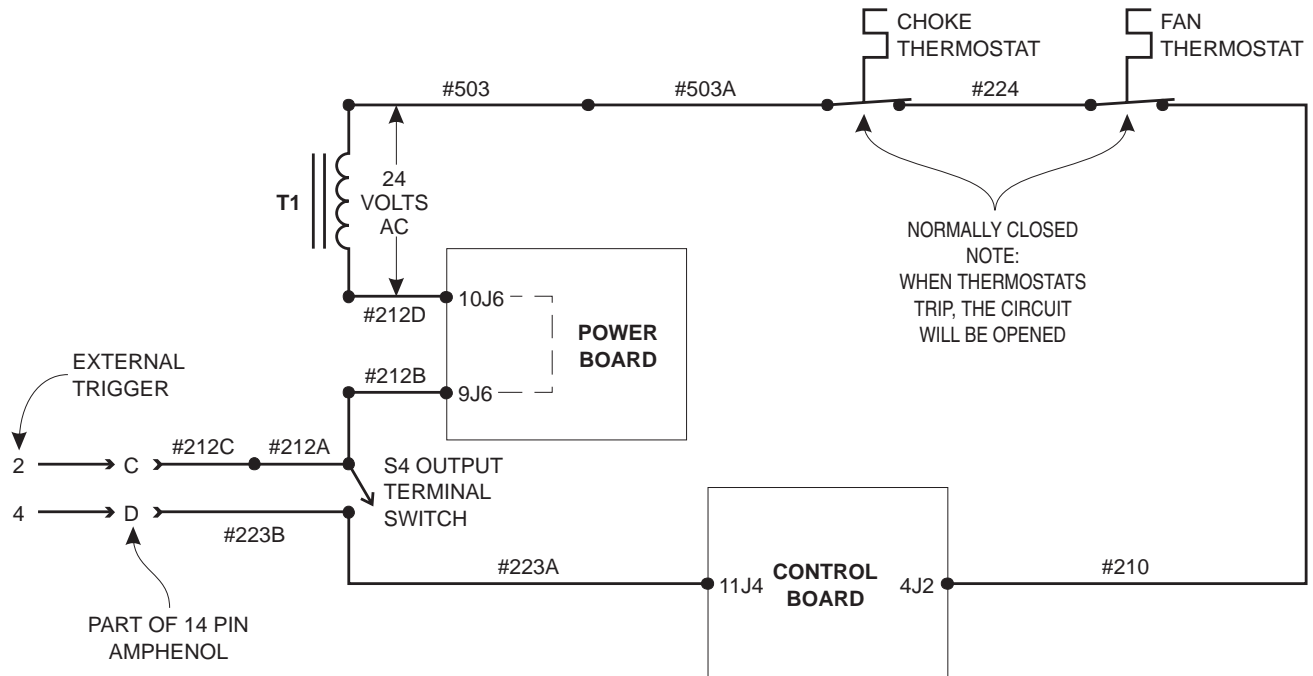

4. Locate the Auxiliary Transformer T1 and leads used for test. See Figure F.21.
5. Turn main power ON.
6. Test Auxiliary Transformer voltage for 24 VAC between leads 503 and 212D. See Figure F.21.
 - a. If 24 VAC is present, transformer is OK. Go to step 7.
 - b. If 0 VAC is present, test input voltage to Auxiliary Transformer.
 - c. If input voltage to Auxiliary Transformer is correct, replace Auxiliary Transformer.
 - d. If input voltage to Auxiliary Transformer is not correct, check Line Switch S12 and connecting leads.
7. Check that Output Terminal Switch S4 is in the ON position (closed).
8. Test for 24 VAC between leads 223A and 210.
 - a. If 24 VAC is present, then AC Trigger Circuit is functioning normally.
 - b. If 0 VAC is present, check Choke Thermostat and Fan Thermostat.

Return to Section TOC

Return to Section TOC

Return to Section TOC

Return to Section TOC

Return to Master TOC

Return to Master TOC

Return to Master TOC

V300-PRO



POWER BOARD TEST



WARNING

Service and repair should be performed by only Lincoln Electric factory trained personnel. Unauthorized repairs performed on this equipment may result in danger to the technician or machine operator and will invalidate your factory warranty. For your safety and to avoid electrical shock, please observe all safety notes and precautions detailed throughout this manual.

If for any reason you do not understand the test procedures or are unable to perform the test / repairs safely, contact the Lincoln Electric Service Department for electrical troubleshooting assistance before you proceed. Call 1-888-935-3877.

TEST DESCRIPTION

This procedure will help to determine if the Power Board or associated circuitry is defective.

MATERIALS NEEDED

- Volt/ohm Meter (multimeter)
- Misc. Hand Tools
- Wiring Diagram (Section G)

V300-PRO



POWER BOARD TEST (cont.)

TEST PROCEDURE

NOTE: Perform Test A before disassembling the unit

Test A

1. Turn main power OFF.
2. Position yourself at Switch Board area of the machine (near Case Back) so as to hear the operation of the control relays.
3. Turn main power ON.

4. Listen for control relays to operate (audible click of contacts closing) after about a 5-second delay.

- a. If audible click of control relay contacts closing is heard, Power Board is probably OK.
- b. If audible click of control relay contacts closing is not heard, Power Board could be faulty. Go to **Test B**.

NOTE: If the relays energize but there is still a suspicion that the Power Board is faulty, go on to **Test B**.

FIGURE F.22 - REMOVING CONTROLPANEL

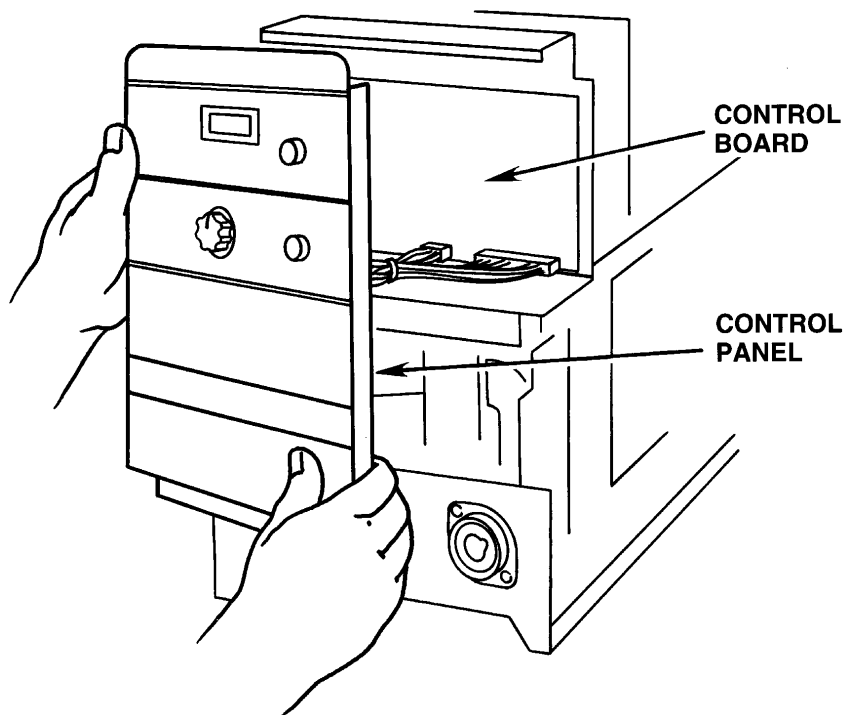

Test B

1. Turn main power OFF.
2. Remove wrap-around cover.
3. Perform *Input Filter Capacitor Discharge* procedure.

4. Detach Control Panel by removing the four mounting screws. Move the panel to the left to gain access to the Power Board.
5. Turn main power ON.

V300-PRO

POWER BOARD TEST (cont.)

FIGURE F.23 - POWER BOARD TEST POINTS

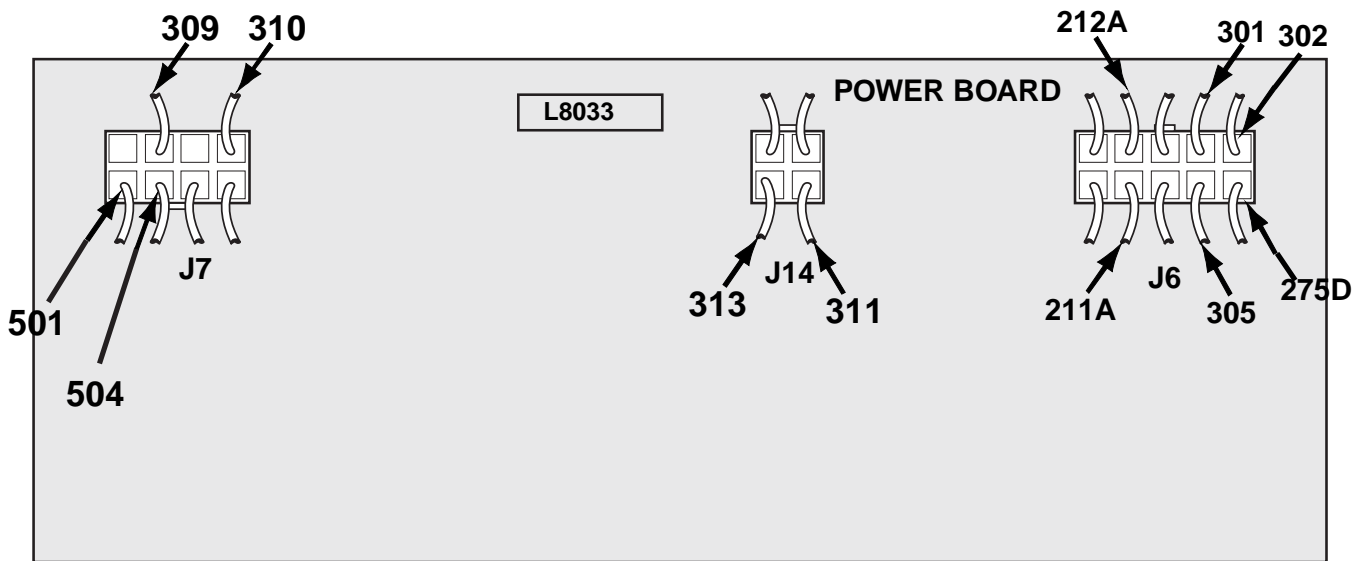

6. Test for 18 VAC input from Auxiliary Transformer between leads 504 and 501 (J7-pin 5 & pin 6) on Power Board.

If 18 VAC is not correct, check the 3 amp fuse, the Auxiliary Transformer and associated wires.

7. Test for 15 VDC output between leads 275D (-) and 302 (+) (J6-pin1 & pin 6) on Power Board.

If 15 VDC output is not present, replace Power Board.

NOTE: If relays energized in Step 4a, skip to Step 10.

8. Test for 24 VAC from lead 211A to lead 212A (J6-pin 4 & pin 9).

If 24VAC is not present, test the Auxiliary transformer and associated wires. The Control Board or thermostats may also be defective. (See Fig. F.24).

9. Test for 24VDC from lead 309 (+) to lead 313 (-) (J7pin 2 to J14 pin 2).

If 24VDC is not present but 24VAC (step 8) is correct, the Power Board is defective.

10. Test for 24VDC from lead 309(+) to lead 310(-) (J7 pin 2 to J7 pin 4).

If 24 VDC is not present, check the voltage from lead 311(+) to lead 313(-).

If the voltage is greater than 1VDC, perform the **Protection Board** test.

If the voltage is approximately 1vdc and the 24vdc is not present between leads 309 & 310, the Power Board is defective

POWER BOARD TEST (cont.)

FIGURE F.24 - SIMPLIFIED TRIGGER CIRCUIT

SIMPLIFIED TRIGGER CIRCUIT

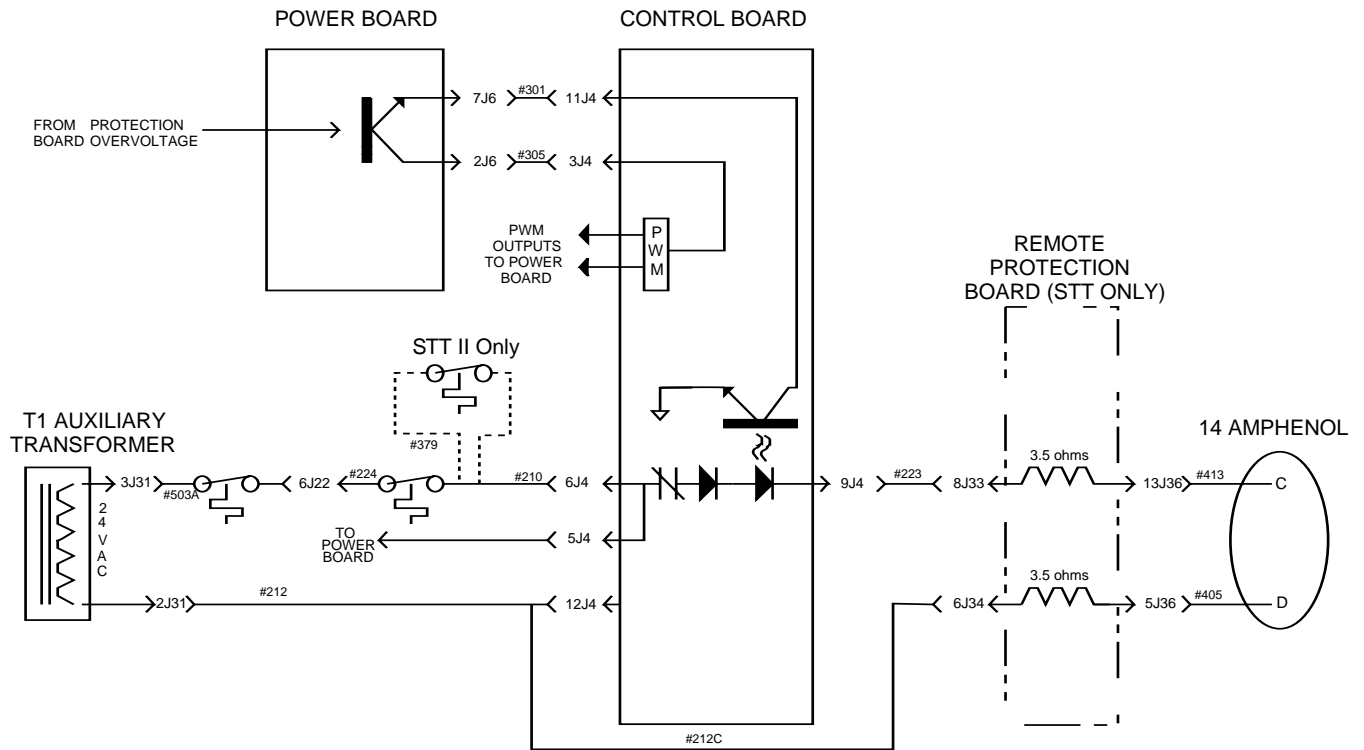

Return to Section TOC

Return to Section TOC

Return to Section TOC

Return to Section TOC

Return to Master TOC

Return to Master TOC

Return to Master TOC

Return to Master TOC

CAPACITOR REMOVAL AND REPLACEMENT PROCEDURE



WARNING

Service and repair should be performed by only Lincoln Electric factory trained personnel. Unauthorized repairs performed on this equipment may result in danger to the technician or machine operator and will invalidate your factory warranty. For your safety and to avoid electrical shock, please observe all safety notes and precautions detailed throughout this manual.

If for any reason you do not understand the test procedures or are unable to perform the test / repairs safely, contact the Lincoln Electric Service Department for electrical troubleshooting assistance before you proceed. Call 1-888-935-3877.

DESCRIPTION

This procedure will aid in the replacement of the Input Filter Capacitors.

MATERIALS NEEDED

- Misc. Hand Tools
- Torque Wrench (60 in./lb.)
- Wiring Diagram (Section G)

NOTE: CAPACITORS MUST ALL BE CHANGED AS A SET IF ANY ARE DEFECTIVE.

V300-PRO



CAPACITOR REMOVAL AND REPLACEMENT (cont.)

PROCEDURE

NOTE: When replacing capacitors, remove the entire FET Heat Sink Assembly as a unit.

Remove and reassemble one side at a time, using the other side as a model to insure that all parts are reinstalled properly

1. Perform the *Input Filter Capacitor Discharge Procedure*.

2. Remove the two 3/8" hex nuts from the top of the through bolts. The hex nuts are located on top of the fan shroud See Figure F.25.

FIGURE F.25 - REMOVING HEX NUTS

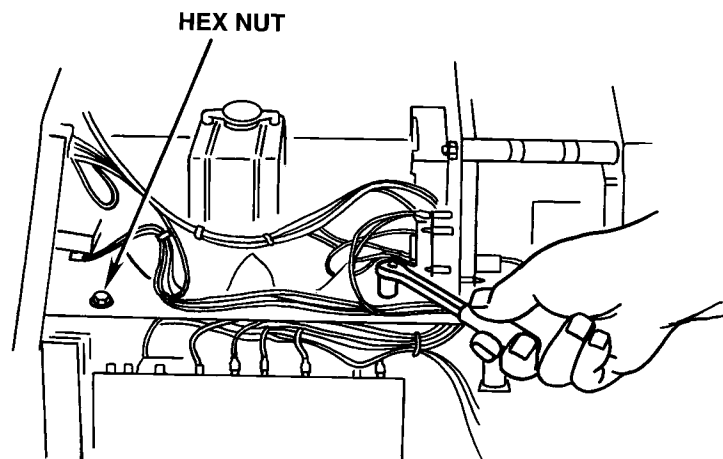

3. Turn the machine on it's side as shown in Figure F.26. Slide the plastic insulators that go through the base to one side and pull out the through bolts, being careful to save all of the insulation and stand-off material. Set aside and save for reassembly.

FIGURE F26 - REMOVING THROUGH BOLTS

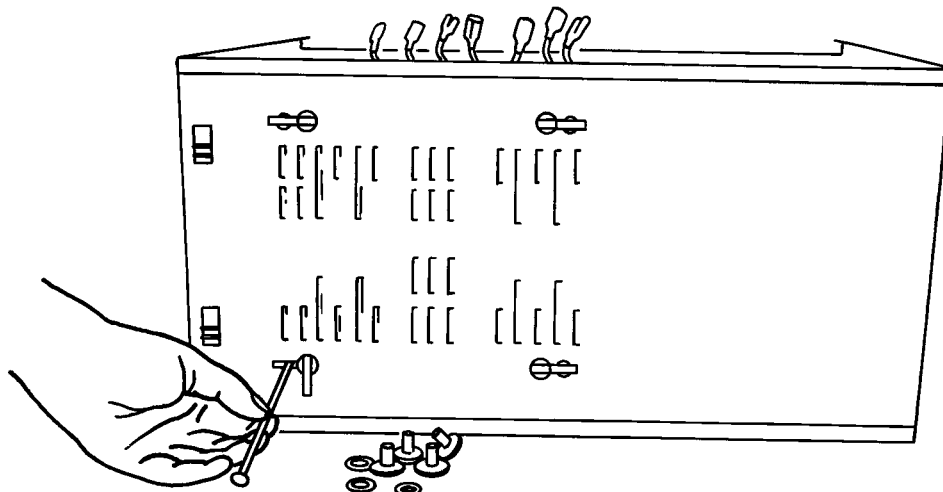

V300-PRO

LINCOLN
ELECTRIC

CAPACITOR REMOVAL AND REPLACEMENT (cont.)

FIGURE F.27 -- REMOVING CAPACITOR NUTS

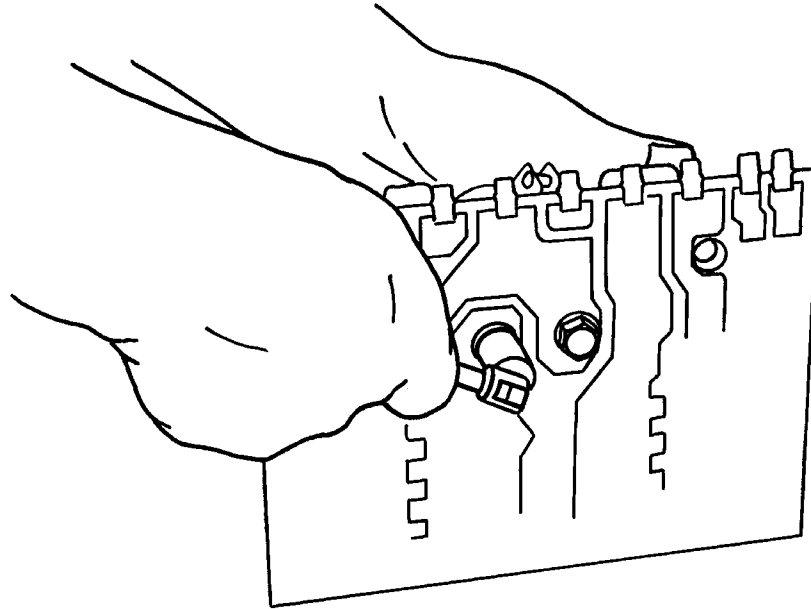

4. Remove the two 1/4-28 hex head bolts that hold the Capacitor to the PC board. See Figure F.27.
5. Loosen the set screw of the Capacitor clamp ring and remove the Capacitor from the clamp ring. See Figure F.28.

FIGURE F.28 — LOOSENING THE CLAMP RING SET SCREW.

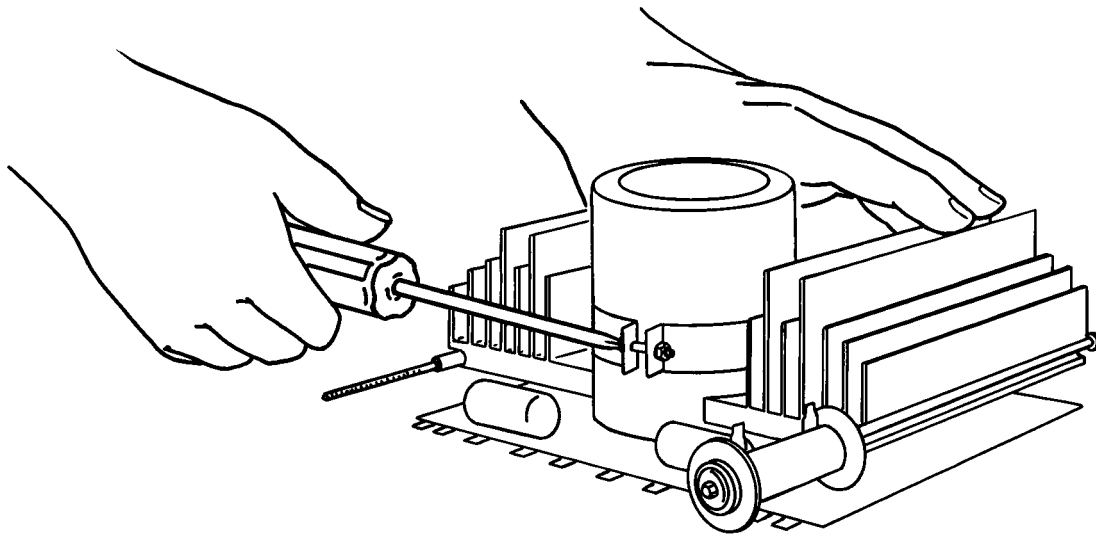

V300-PRO

 LINCOLN
ELECTRIC

CAPACITOR REMOVAL AND REPLACEMENT (cont.)

FIGURE F.29 -- COMPLETE SWITCH BOARD ASSEMBLY READY FOR INSTALLATION

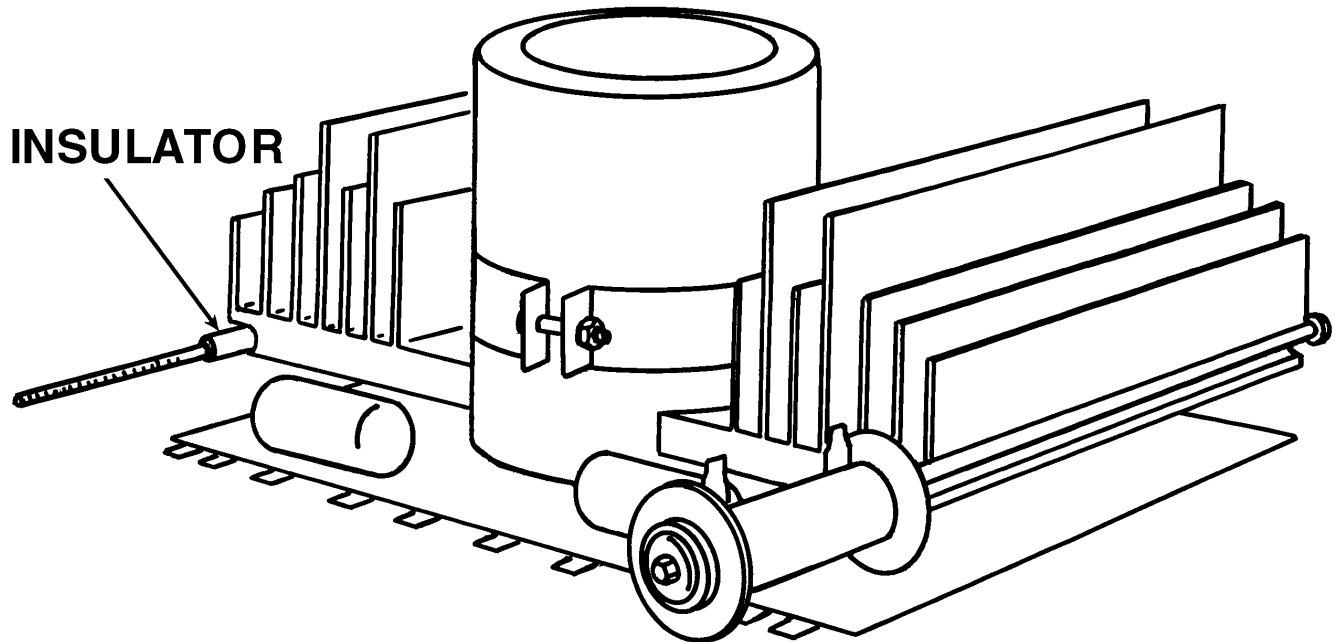

NOTE: Proper capacitor polarity must be noted when attaching the capacitor to the Switch Board assembly.

6. Install the new Capacitor and tighten the two bolts to a torque of 55 inch-pounds (6 Nm). Hand tighten first, then tighten the bolts in increments of 10 inch-pounds, alternating between the two. See *Figure F.27*.
7. Tighten the set screw of the clamping ring
8. Perform the *Test After Repair of Switch Boards and/or Capacitors*.

SWITCH BOARD REMOVAL AND REPLACEMENT PROCEDURE



WARNING

Service and repair should be performed by only Lincoln Electric factory trained personnel. Unauthorized repairs performed on this equipment may result in danger to the technician or machine operator and will invalidate your factory warranty. For your safety and to avoid electrical shock, please observe all safety notes and precautions detailed throughout this manual.

If for any reason you do not understand the test procedures or are unable to perform the test / repairs safely, contact the Lincoln Electric Service Department for electrical troubleshooting assistance before you proceed. Call 1-888-935-3877.

DESCRIPTION

This procedure will aid in the replacement of the Switch Boards.

MATERIALS NEEDED

- Misc. Hand Tools
- Torque Wrench (60 in./lb.)
- Wiring Diagram (Section G)

NOTE: BOTH SWITCH BOARDS IN A MACHINE MUST HAVE IDENTICAL PART NUMBERS. THEY SHOULD ALWAYS BE CHANGED IN PAIRS EXCEPT FOR L10958-[] BOARDS WHICH MAY BE REPLACED INDIVIDUALLY

V300-PRO



SWITCH BOARD REPLACEMENT (cont.)

NOTE: If a test indicates that a Switch Board is defective, unless their part number is **L10958-[]** both Switch Boards must be replaced at the same time. In addition to replacing the Switch Boards, Capacitors C1 and C2 (plus C14 and C15 on 575 VAC models) must also be replaced if the following conditions exist:

- The part number of the Switch Boards is something other than **L10985-[]**
- The machine was operating from 380 VAC or higher when the failure occurred.
- Burned areas are visible on the Switch Boards.

PROCEDURE

- Perform the **Input Filter Capacitor Discharge Procedure**.
- Remove the Switch Board assembly from the machine as directed in the **CAPACITOR REPLACEMENT PROCEDURE**.
- Remove the four socket head screws that hold the Switch Board to the heat sink.
- Remove the 1/4"-28 hex head capacitor mounting screws.
- Remove the Switch Board from the heat sink.
- Clean the heat sink surfaces thoroughly to remove all the heat sink compound. During machine operation, this compound helps conduct heat from the PC board to the heat sinks.
- Apply a thin layer (.002") of Dow 340 or Penetrox A13 Heat Sink Compound to the mounting surfaces of the new PC board and to the Capacitor terminals. DO NOT allow the compound to enter the mounting screw holes because it can distort the torque values.
- Prepare to mount the new PC board on the heat sink by first lining up the mounting holes. Then press the PC board into place.
- Insert each of the four socket head screws into the mounting holes and thread finger tight. The threads are soft — be careful not to cross thread the screws.
- Loosen the capacitor mounting bracket tightening screw. **See Figure F.28.**
- Torque both sets of screws in 10 inch-pound increments using a diagonal tightening sequence. Torque the four socket head screws to 44 inch-pounds (5 Nm). Torque the two hex head capacitor screws to 55 inch-pounds (6 Nm).
- Tighten the capacitor mounting bracket mounting screw
- Remount the assembly into the machine
- Reconnect all the leads to the PC board. Double check that each lead is connected to the correct terminal. Failure to reconnect the leads correctly can result in machine damage when the power is applied.
- Perform the **Test After Repair of Switch Boards and/or Capacitors**.

V300-PRO



TEST AFTER SWITCH BOARD OR CAPACITOR REPLACEMENT



WARNING

Service and repair should be performed by only Lincoln Electric factory trained personnel. Unauthorized repairs performed on this equipment may result in danger to the technician or machine operator and will invalidate your factory warranty. For your safety and to avoid electrical shock, please observe all safety notes and precautions detailed throughout this manual.

If for any reason you do not understand the test procedures or are unable to perform the test / repairs safely, contact the Lincoln Electric Service Department for electrical troubleshooting assistance before you proceed. Call 1-888-935-3877.

DESCRIPTION

This test MUST be performed after replacement of either the Switch Boards or Input Filter Capacitors.

MATERIALS NEEDED

- Misc. Hand Tools
- Small jumper or clip lead
- Wiring Diagram (Section G)

NOTE: BOTH SWITCH BOARDS IN A MACHINE MUST HAVE IDENTICAL PART NUMBERS. THEY SHOULD ALWAYS BE CHANGED IN PAIRS EXCEPT FOR L10958-[] BOARDS WHICH MAY BE REPLACED INDIVIDUALLY

V300-PRO



TEST AFTER SWITCH BOARD OR CAPACITOR REPLACEMENT (cont.)

TEST PROCEDURE

1. Turn main power OFF.
2. Perform **Input Filter Capacitor Dis-charge** procedure detailed in Maintenance section..
3. Connect a shorting conductor across terminals 14 and 53 of Protection Board.
4. Set an ohmmeter to X1000 range and place probes on terminals 9 (+) and 12 (-) of one Switch Board. The meter will show the Capacitors charging up and may take a minute or so to stabilize. The final meter reading should not exceed 8600 ohms (8.6 on the scale).
5. Test the other Switch Board the same way.

NOTE: Repeat the **Input Filter Capacitor Dis-charge** procedure.

6. Remove the shorting conductor set up in step 3.
7. Install 5-amp fuses in the input supply fuse holders.

NOTE: These fuses should be installed to protect against excessive current flow caused by a short circuit during the procedure.

8. Turn on the machine.
9. With the output free of a load, check the open circuit voltages of the output.
10. Connect the machine for 440- or 575-volt operation.
11. With the output free of a load, check open circuit voltages of the output. Voltage should be 70 VDC.
12. Remove the 5-amp fuse from the input supply fuse holders.
13. Install 20-amp fuses and test under load.

NOTE: A resistive-type grid load bank is recommended.

14. Perform **Retest After Repair**.

FIGURE F.30 - PLACEMENT OF SHORTING JUMPER

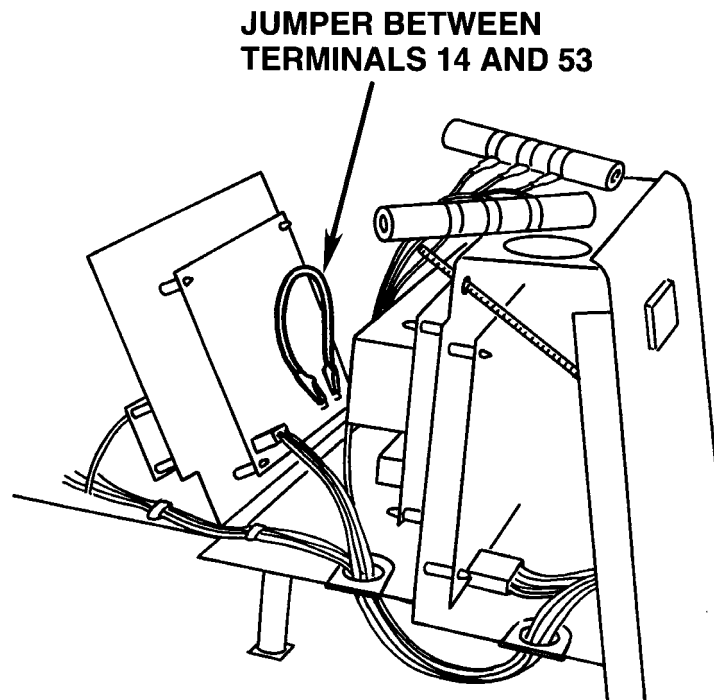

OUTPUT DIODE REPLACEMENT PROCEDURE



WARNING

Service and repair should be performed by only Lincoln Electric factory trained personnel. Unauthorized repairs performed on this equipment may result in danger to the technician or machine operator and will invalidate your factory warranty. For your safety and to avoid electrical shock, please observe all safety notes and precautions detailed throughout this manual.

If for any reason you do not understand the test procedures or are unable to perform the test / repairs safely, contact the Lincoln Electric Service Department for electrical troubleshooting assistance before you proceed. Call 1-888-935-3877.

DESCRIPTION

This procedure will aid in the replacement of the Output Diodes.

MATERIALS NEEDED

- Misc. Hand Tools
- Torque Wrench (60 in./lb.)
- Wiring Diagram (Section G)

NOTE: Most Output Rectifier Assemblies are made with two sets of five individual diodes connected in parallel. If one or more diodes in a set fails, all five must be replaced.

Some Output Rectifier Assemblies are made with Diode Modules. It is only necessary to replace the Defective part on these units

V300-PRO



OUTPUT DIODE REPLACEMENT PROCEDURE (cont.)

FIGURE F.31 - RECTIFIER ASSEMBLY WITH PARALLELED DIODES

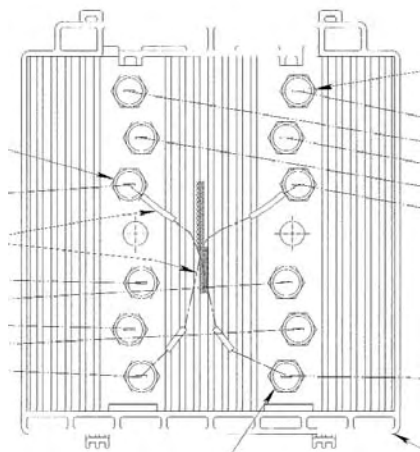
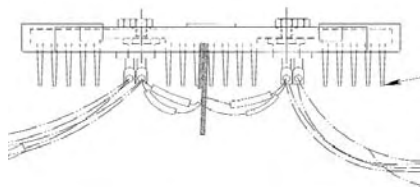

PROCEDURE (Paralleled Individual Diodes)

1. Turn main power OFF.
2. Perform **Input Filter Capacitor Discharge** procedure detailed in Maintenance section..
3. Detach and remove both Switch Board assemblies and attached capacitors. See **Switch Board Removal and Replacement** procedure
4. Detach the fan shroud to gain access to the diode heat sink and mounting bracket. When the fan shroud is lifted, the tabs securing the heat sink mounting bracket will release.
5. Move the diode heat sink and mounting bracket away from the Case Back.
6. Unsolder the leads from each of the diodes to be replaced.
7. Remove the nut that secures each diode to the heat sink and mounting bracket.
8. Mount the replacement diodes to the heat sink.
IMPORTANT: The replacement diodes will come with an instruction sheet that addresses surface preparation and torque values. Failure to follow these instructions may result in subsequent break down.
9. Carefully resolder the leads to the new diodes.
10. Reassemble the unit being careful to use all of the insulating materials. Also make certain to replace all disconnected leads in their proper location. Failure to do so may result in machine damage when the power is applied.
11. Perform the **Test After Switch Board or Capacitor Replacement** .

V300-PRO



OUTPUT DIODE REPLACEMENT PROCEDURE (cont.)

FIGURE F.32 - RECTIFIER ASSEMBLY WITH DIODE MODULES

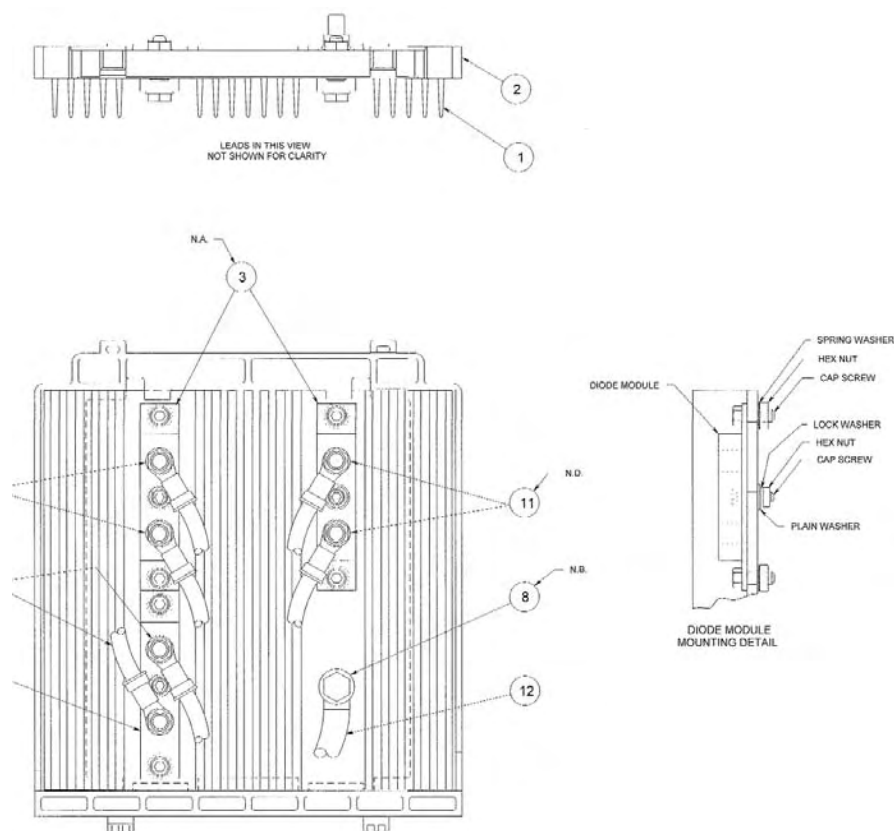

PROCEDURE (Diode Modules)

1. Turn main power OFF.
2. Perform **Input Filter Capacitor Discharge** procedure detailed in Maintenance section..
3. Detach and remove both Switch Board assemblies and attached capacitors. See **Switch Board Removal and Replacement** procedure
4. Detach the fan shroud to gain access to the diode heat sink and mounting bracket. When the fan shroud is lifted, the tabs securing the heat sink mounting bracket will release.
5. Move the diode heat sink and mounting bracket away from the Case Back.
6. Disconnect the leads from the defective Module and remove the module from the heat sink.
7. Mount the new module and re-connect the leads. **IMPORTANT:** The replacement module will come with an instruction sheet that addresses surface preparation, torque values and hardware changes. Failure to follow these instructions may result in subsequent breakdown.
8. Reassemble the unit being careful to use all of the insulating materials. Also make certain to replace all disconnected leads in their proper location. Failure to do so may result in machine damage when the power is applied.
9. Perform the **Test After Switch Board or Capacitor Replacement**.

RETEST AFTER REPAIR

Should a machine under test be rejected for any reason requiring the removal of any mechanical part that could affect the machine's electrical characteristics, or if any electrical components are repaired or replaced, the machine must be retested.

NOTE: 50 Hz machines may be tested using 60 Hz power.

INPUT IDLE AMPS AND IDLE WATTS

Input Volts/Hertz	Single Phase		Three Phase	
	Max. Amps	Max. Watts	Max. Amps	Max. Watts
220/50 or 60	2.75	425	2.75	425
230/60	3.00	450	3.00	450
440/50 or 60	1.38	425		
460/60	1.50	450		
380/50 or 60	1.67	425		
575/60	—	—		

OCV at rated INPUT: V300-PRO, V300-I 60-75V

MAXIMUM ACCEPTABLE OUTPUT AMPS (AT MINIMUM OUTPUT SETTINGS)

Output		
Min. (Max. acceptable), all machines:		
CC modes	12A @ 10V.	(GTAW, SOFT, CRISP)
CV modes	20A @ 19V.	(FCAW, GMAW)

OUTPUT MINIMUM ACCEPTABLE VOLTS (AT MAXIMUM OUTPUT SETTINGS, WITH FULL LOAD)

Min. Acceptable, Max. — All Modes	V300-I		V300-PRO		
	1 phase @ 200A	380V —	220/440V 38V	208V —	230/460V 38V
3 phase @ 300A	32V	36V	34V	38V	36V

AUXILIARY TRANSFORMER — 50 Hz or 60 Hz

TEST POINTS	RANGE
18 VAC winding to Power Board J7 pins 5 and 6 Welding terminals sw. remote	17-20 VAC
24 VAC winding to Control Board J2 pin 4 to lead 212	23-26.5 VAC
STANDARD CODES: (Test at Amphenol)	
24 VAC without load, measure across pins C and D	22-25 VAC
42 VAC without load, measure across pins I and K	39-44 VAC
115 VAC without load, measure across pins A and J	109-120 VAC

V300-PRO



TABLE OF CONTENTS - ELECTRICAL DIAGRAMS SECTION -

Return to Master TOC

Return to Master TOC

Return to Master TOC

Return to Master TOC

Electrical DiagramsSection G

Wiring Diagram (L8657 for Code 9825 & 9965)G-2

Wiring Diagram (L8841 for Code 9934)G-3

Wiring Diagram (L9299 for Code 10034)G-4

Wiring Diagram (L9301 for Code 10035)G-5

Wiring Diagram (L9567 for Code 10130)G-6

Wiring Diagram (L9569 for Code 10131)G-7

Wiring Diagram (L10189 for Code 10256)G-8

Wiring Diagram (L10191 for Code 10257)G-9

Entire Machine SchematicG-10

Driver PC Board Schematic (S20216)G-11

Driver PC Board Assembly (L8660-[])G-12

Driver PC Board Schematic (S20799)G-13

Driver PC Board Assembly (L9134-[])G-14

Switch Board Schematic (L8440)G-15

Switch Board Assembly (L8441)G-16

Switch Board Schematic (L10956)G-17

Switch Board Assembly (L10958-1)G-18

Control PC Board Schematic (G2525)G-19

Control Board Assembly (G2527-3)G-20/G-21

Protection Board Schematic (M16097)G-22

Protectoin Board Assembly (L7915-2)G-23

Power Board Schematic (M16018)G-24

Power Board Assembly (L8033-7)G-25

* NOTE: Many PC Board Assemblies are now totally encapsulated and are therefore considered to be unserviceable. The Assembly drawings are provided for reference only.

WIRING DIAGRAM - ENTIRE MACHINE - CODE 9825 & 9965 (L8657)

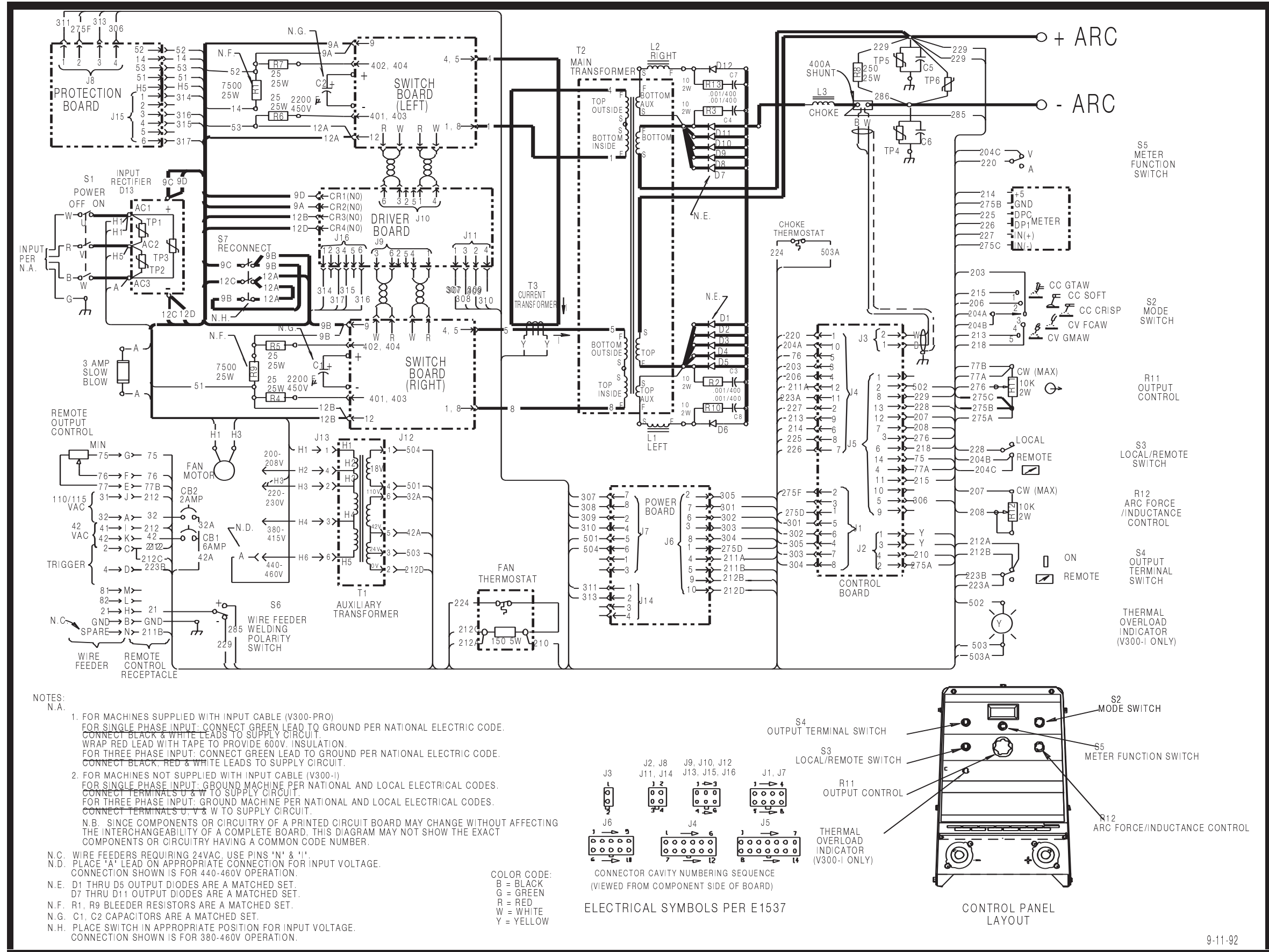

9-11-92

NOTE: This diagram is for reference only. It may not be accurate for all machines covered by this manual. The wiring diagram specific to your code is pasted inside one of the enclosure panels of your machine.



WIRING DIAGRAM - ENTIRE MACHINE CODE 9934 (L8841)

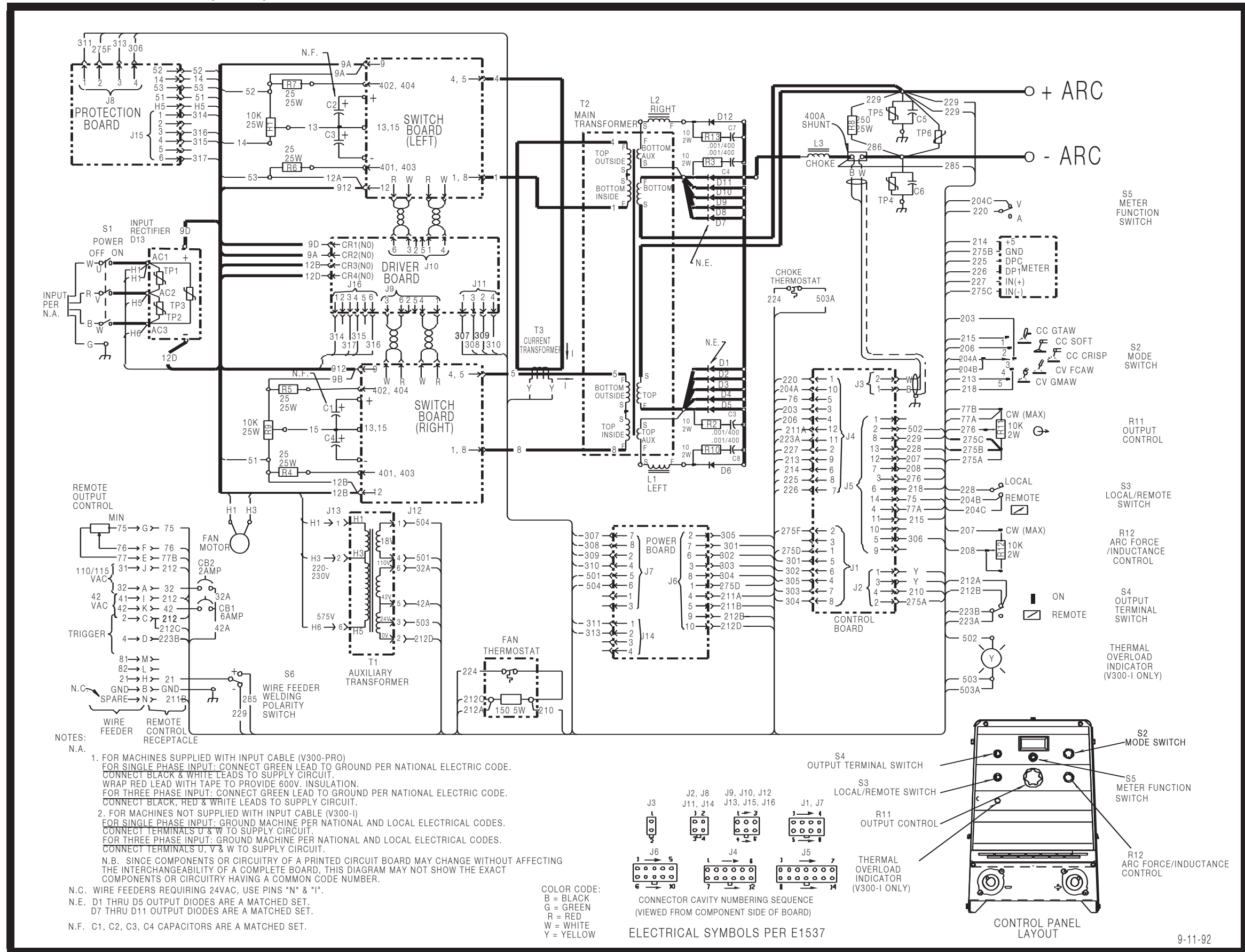

CLEVELAND, OHIO U.S.A.

NOTE: This diagram is for reference only. It may not be accurate for all machines covered by this manual. The wiring diagram specific to your code is pasted inside one of the enclosure panels of your machine.

Return to Section TOC

Return to Master TOC

Return to Section TOC

Return to Master TOC

Return to Section TOC

Return to Master TOC

Return to Section TOC

Return to Master TOC

WIRING DIAGRAM - ENTIRE MACHINE CODE 10034 (L9299)

Return to Section TOC
Return to Master TOC

Return to Section TOC
Return to Master TOC

Return to Section TOC
Return to Master TOC

Return to Section TOC
Return to Master TOC

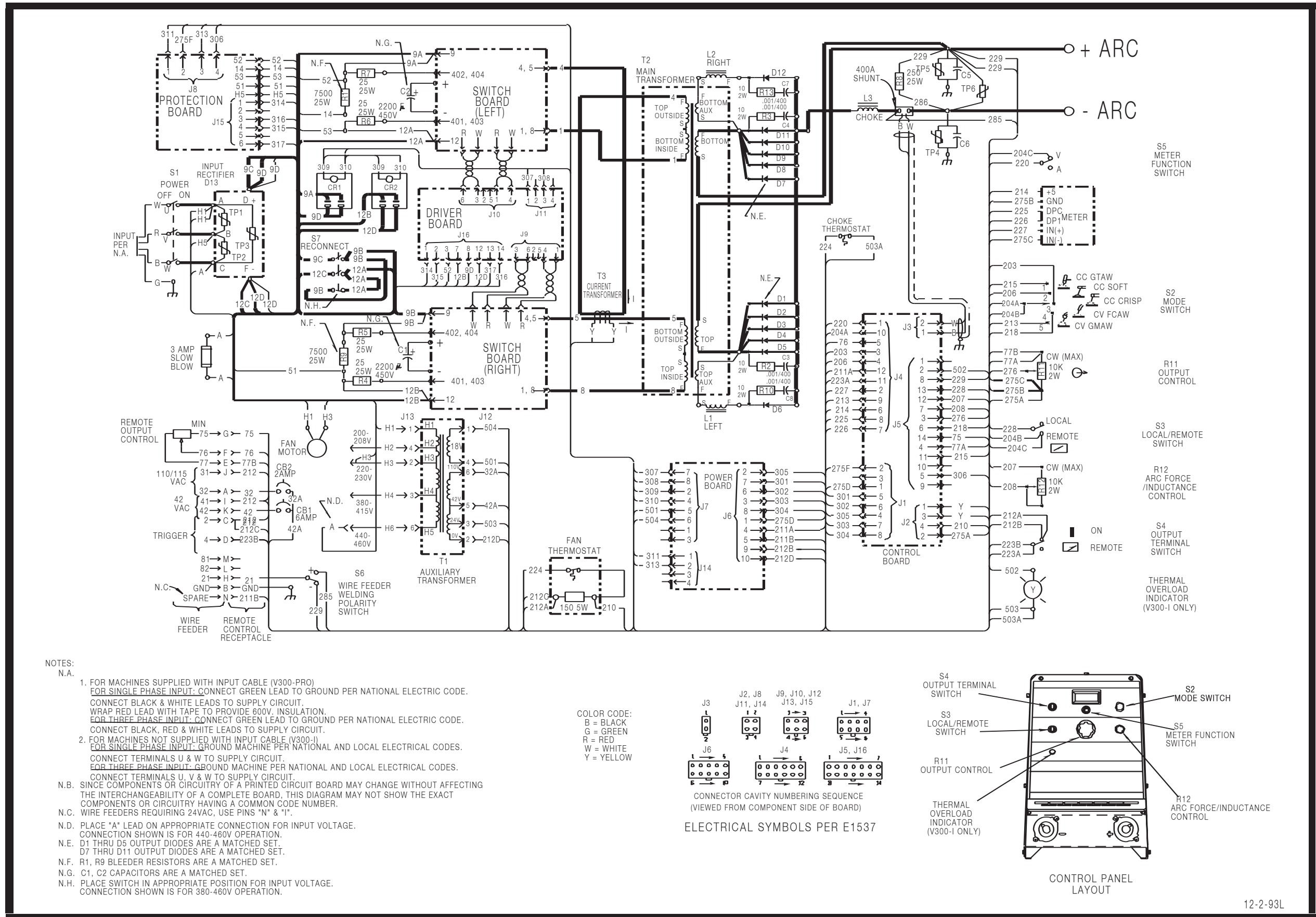

12-2-93L

CLEVELAND, OHIO U.S.A.

L9299

NOTE: This diagram is for reference only. It may not be accurate for all machines covered by this manual. The wiring diagram specific to your code is pasted inside one of the enclosure panels of your machine.

WIRING DIAGRAM - ENTIRE MACHINE CODE 10035 (L9301)

Return to Section TOC
Return to Master TOC

Return to Section TOC
Return to Master TOC

Return to Section TOC
Return to Master TOC

Return to Section TOC
Return to Master TOC

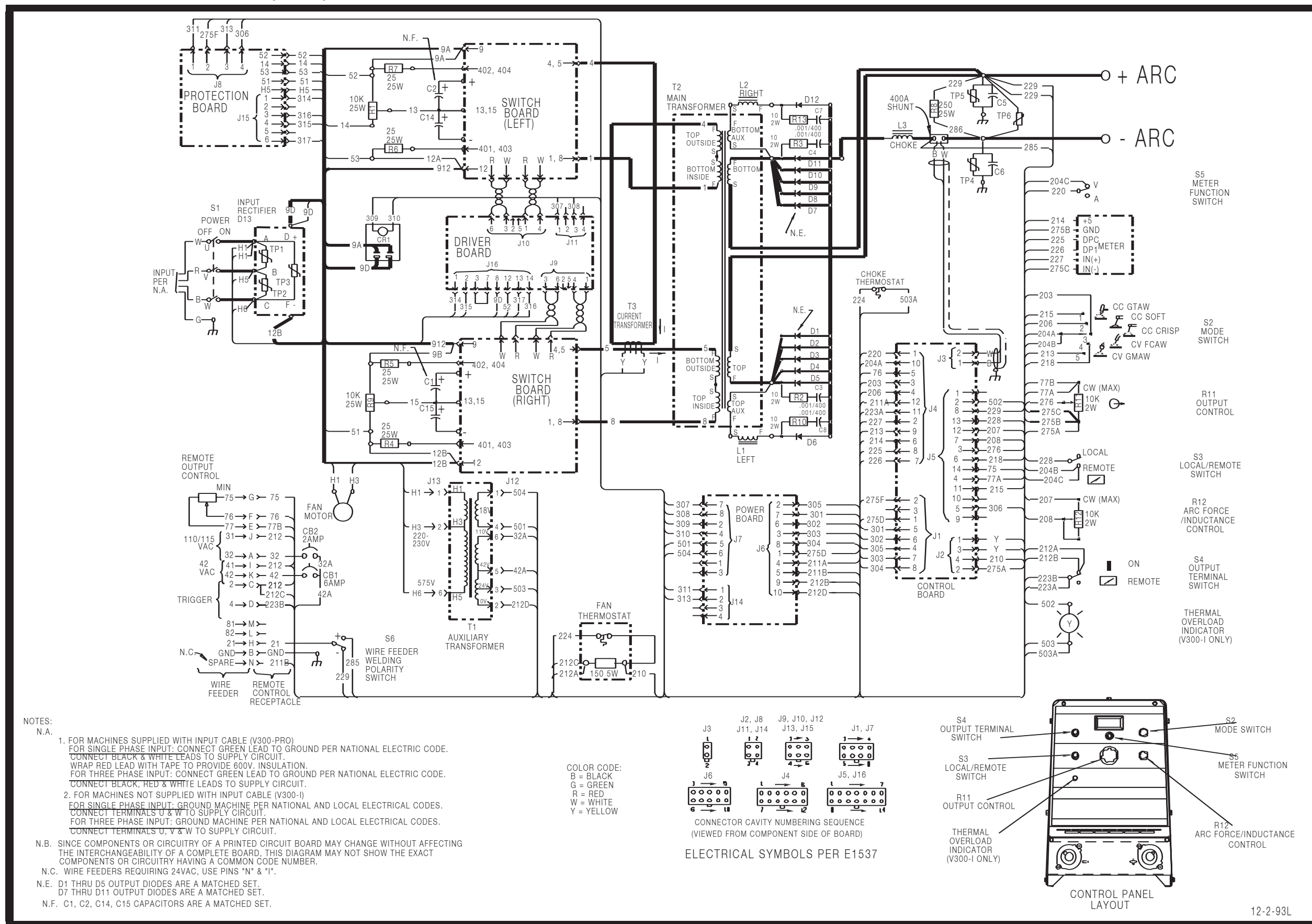

CLEVELAND, OHIO U.S.A.

L9301

NOTE: This diagram is for reference only. It may not be accurate for all machines covered by this manual. The wiring diagram specific to your code is pasted inside one of the enclosure panels of your machine.

WIRING DIAGRAM - ENTIRE MACHINE - CODE 10257 (L10191)

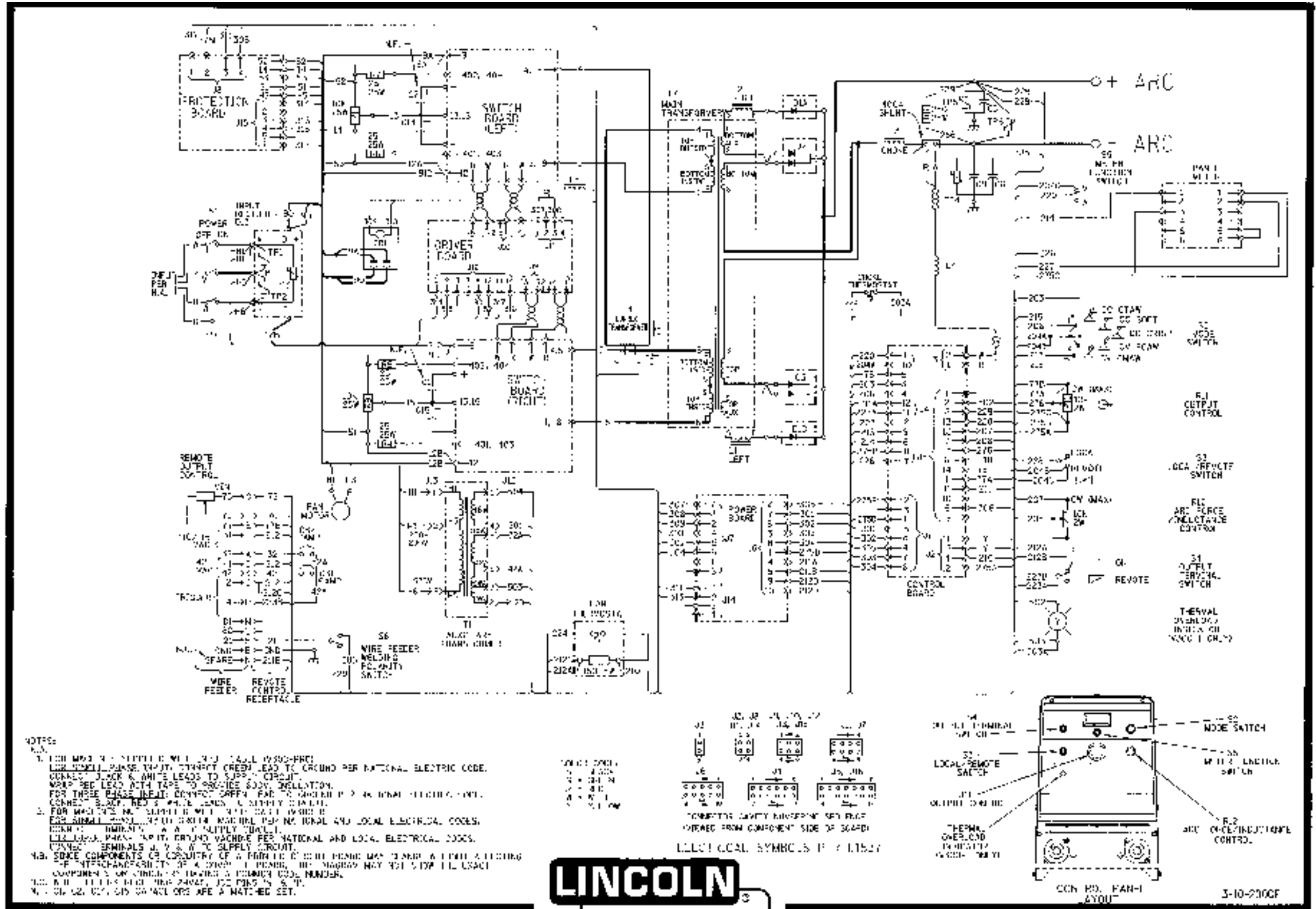

NOTE: This diagram is for reference only. It may not be accurate for all machines covered by this manual. The wiring diagram specific to your code is pasted inside one of the enclosure panels of your machine.



PC BOARD ASSEMBLY - DRIVER - (L8660-[])

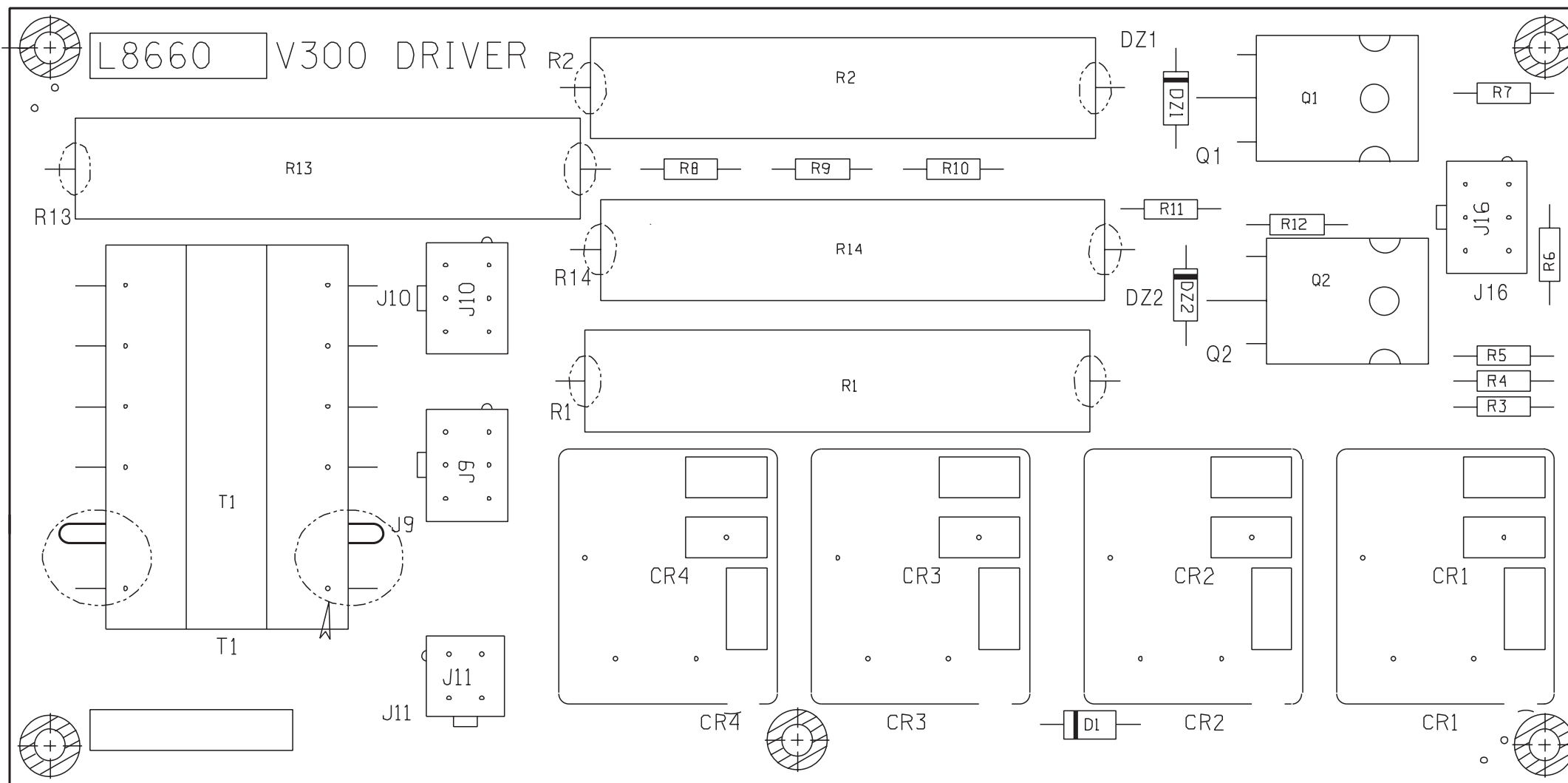

Item	Identification
CR1, CR2, CR3, CR4	RELAY, SPNO 24VDC 6000 ohms AG-CDO
D1	DIODE, AXLDS 1A 400V
DZ1, DZ2	DIODE, Zener 1W 12V 5% 1N4742A
J9, J10, J16	CONNECTOR, Molex mini PCB 6 pin
J11	CONNECTOR, Molex mini PCB 4 pin
P9, P10, P16 (plugs into J9, J10, J16)	PLUG, Molex mini 6 pin
P11 (plugs into J11)	PLUG, Molex mini 4 pin
Q1, Q2	TRANSISTOR, NMFT247 4A 900V
R1, R2, R13, R14	RESISTOR, WW 20W 5% 250K
R3, R4, R5, R6, R8, R9, R7, R12	RESISTOR, MF .25W 1% 150K RESISTOR, MF .25W 1% 100K
T1	TRANSFORMER, PCB

NOTE: Individual parts listed are not available from Lincoln Electric.

NOTE: Lincoln Electric assumes no responsibility for liabilities resulting from board level troubleshooting. PC Board repairs will invalidate your factory warranty. **Individual Printed Circuit Board Components are not available from Lincoln Electric.** This information is provided for reference only. Lincoln Electric discourages board level troubleshooting and repair since it may compromise the quality of the design and may result in danger to the Machine Operator or Technician. Improper PC board repairs could result in damage to the machine.



Return to Section TOC
Return to Master TOC
Return to Section TOC
Return to Master TOC
Return to Section TOC
Return to Master TOC
Return to Section TOC
Return to Master TOC

PC BOARD ASSEMBLY - DRIVER - (9134-[])

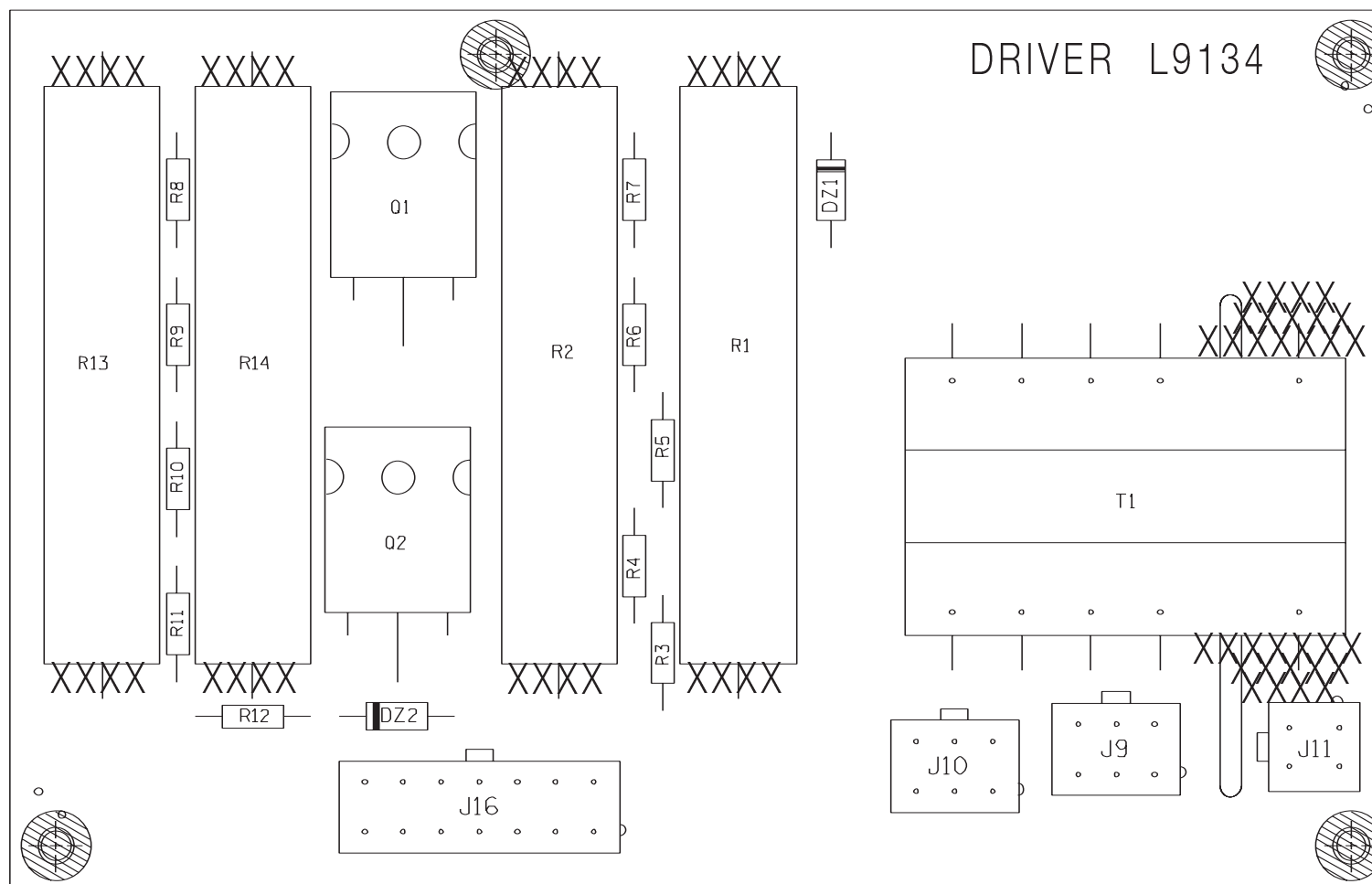

Item	Description
J11	HEADER
J9,J10	HEADER
T1	TRANSFORMER
J16	HEADER
R1,R2,R13,R14	20 WATT 250 OHM RESISTOR
DZ1,DZ2	1N4742A
Q1,Q2	FET (SS)
R7,R12	100 1/4W
R3,R4,R5,R6,R8,R9, R10,R11	150K 1/4W

NOTE: Lincoln Electric assumes no responsibility for liabilities resulting from board level troubleshooting. PC Board repairs will invalidate your factory warranty. **Individual Printed Circuit Board Components are not available from Lincoln Electric.** This information is provided for reference only. Lincoln Electric discourages board level troubleshooting and repair since it may compromise the quality of the design and may result in danger to the Machine Operator or Technician. Improper PC board repairs could result in damage to the machine.

[Return to Section TOC](#)
[Return to Master TOC](#)

SCHEMATIC - SWITCH PC BOARD (L8440)

Return to Section TOC
Return to Master TOC

Return to Section TOC
Return to Master TOC

Return to Section TOC
Return to Master TOC

Return to Section TOC
Return to Master TOC

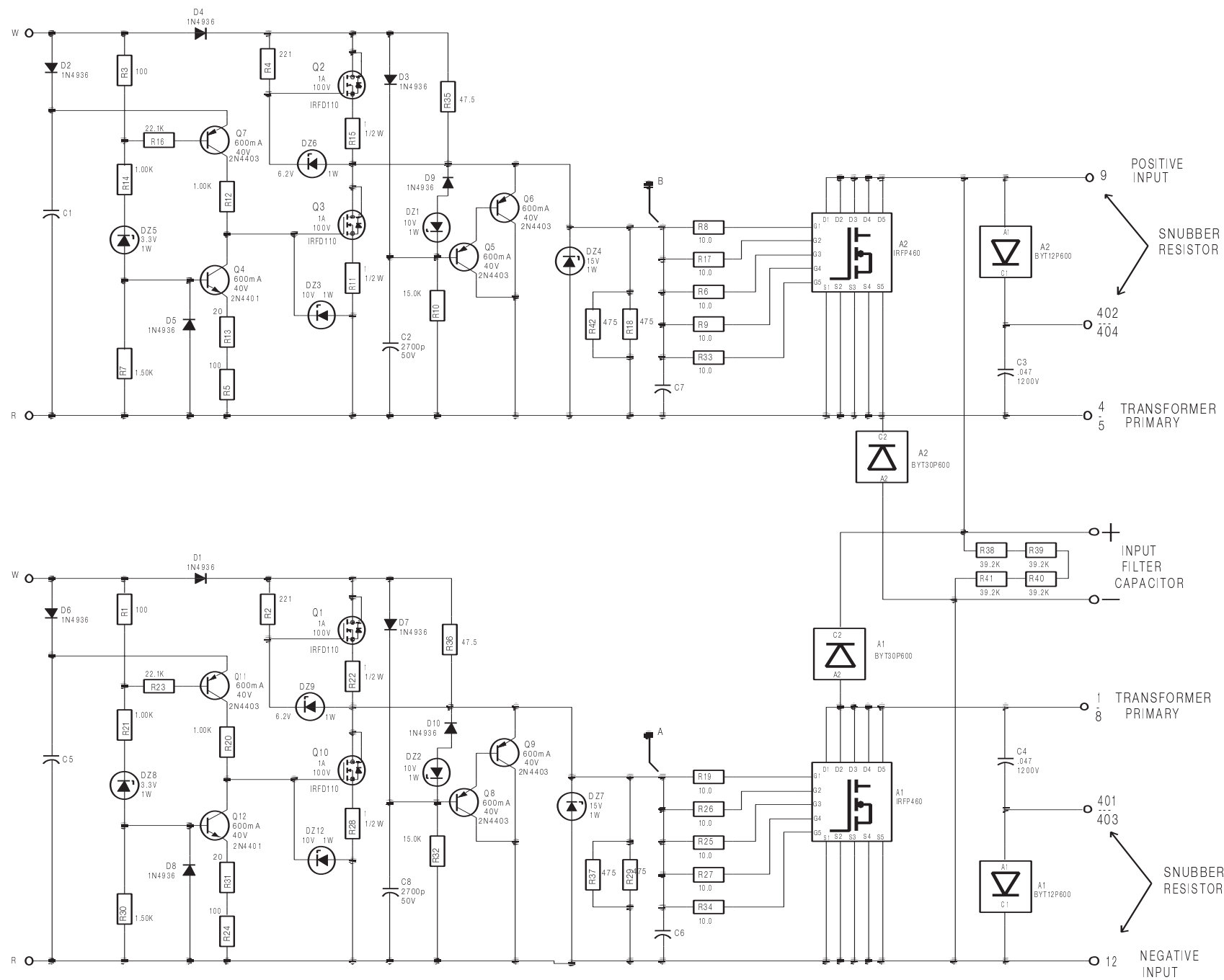

GENERAL INFORMATION

ELECTRICAL SYMBOLS PER E1-1537
 CAPACITORS = MFD (UNLESS OTHERWISE SPECIFIED)
 RESISTORS = Ohms (UNLESS OTHERWISE SPECIFIED)
 DIMENSIONS = IN. (UNLESS OTHERWISE SPECIFIED)

LABELS:

- ⚡ SUPPLY VOLTAGE NET
- ⚡ POWER SUPPLY SOURCE POINT
- ⚡ COMMON CONNECTION
- ⚡ FRAME CONNECTION
- ⚡ EARTH GROUND CONNECTION

INVERTEC V300
 SWITCH BOARD SCHEMATIC
 10-8-88A L 8440

NOTES:

N/A. SINCE COMPONENTS OR SPECIFICITY ON A PRINTED CIRCUIT BOARD MAY CHANGE WITHOUT NOTICE, THIS DIAGRAM MAY NOT SHOW THE EXACT COMPONENTS OR CIRCUITRY OF CONTROLS HAVING A COMMON CODE NUMBER.

NOTE: This diagram is for reference only. It may not be accurate for all machines covered by this manual.



PC BOARD ASSEMBLY - SWITCH - (L8441)

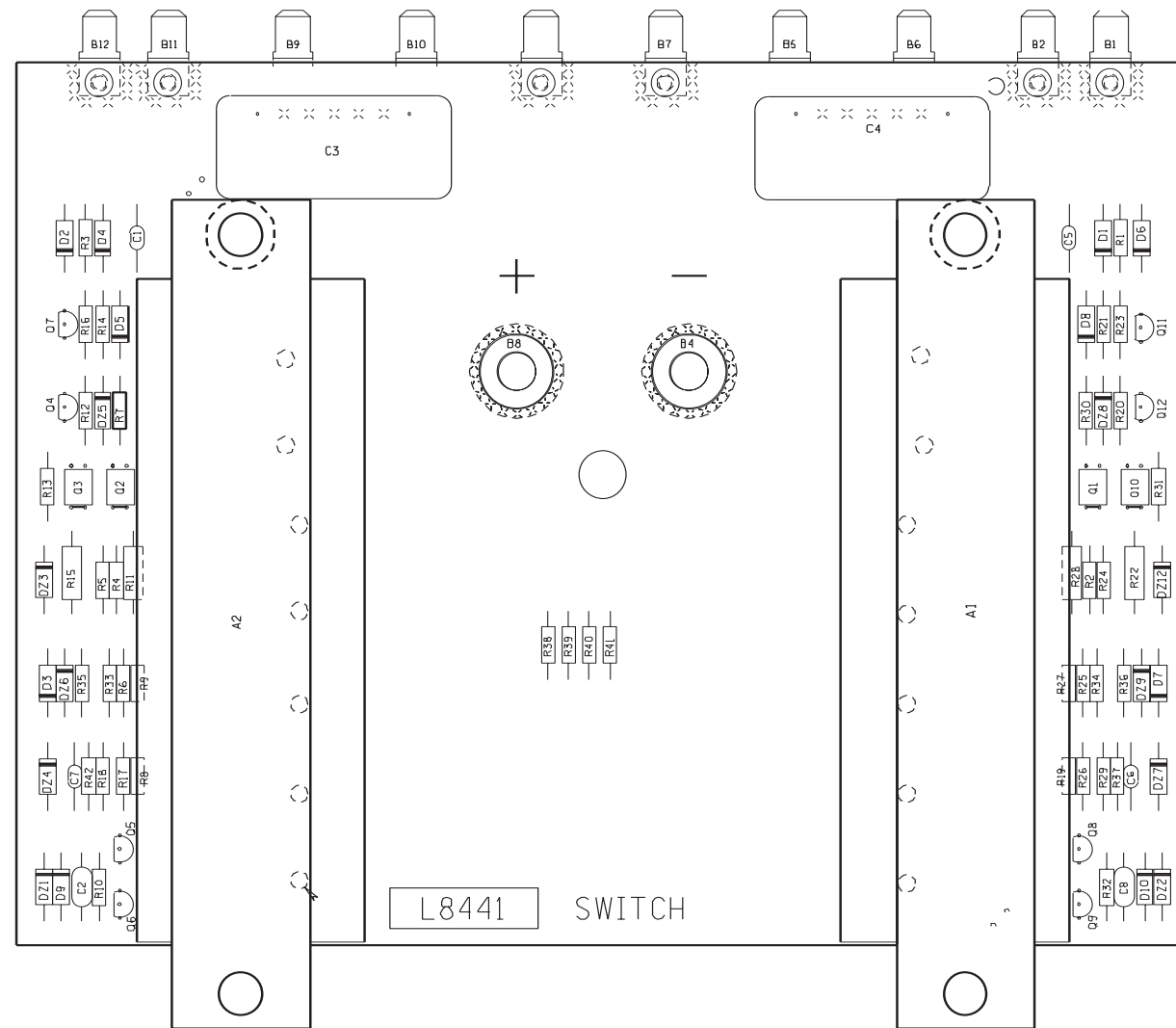

Item	Description
A1	ELECTRONIC MODULE ASSEMBLY
A2	ELECTRONIC MODULE ASSEMBLY
B1, B2, B3, B4, B5, B6, B7, B8, B9, B10, B11, B12	CONNECTOR, tab QC edge offset 1/4"
C1, C5, C6, C7	CAPACITOR,CEMO .022 50V 20%
C2, C8	CAPACITOR, CEMO 2700P 50V 5%
C3, C4	CAPACITOR-PPF, .047 1200V 5%
D1, D2, D3, D4, D5, D6, D7, D8, D9, D10	DIODE, AXLDS 1A 400V FR 1N4936
DZ1, DZ2, DZ3, DZ12	DIODE, Zener 1W 10V 5% 1N4740A
DZ4, DZ7	DIODE, Zener 1W 15V 5% 1N4744A
DZ5, DZ6, DZ8, DZ9	DIODE, Zener 1W 6.2V 5% 1N4735A
Q1, Q2, Q3, Q10	TRANSISTOR-NMF, 4PDIP 1A 100V RFD110
Q4, Q12	TRANSISTOR-N, T226 0.5A 40V 2N4401
Q5, Q6, Q7, Q8, Q9, Q11	TRANSISTOR-P, T226 0.5A 40V 2N4403
R1, R3, R5, R24	RESISTOR-MF, .25W 1% 100 ohm

Item	Description
R2, R4	RESISTOR-MF, .25W 1% 221 ohm
R6, R8, R9, R17, R19, R25, R26, R27, R33, R34	RESISTOR-MF, .25W 1% 10.0 ohm
R7, R30	RESISTOR-MF, .25W 1% 1.50K ohm
R10, R32	RESISTOR-MF, .25W 1% 15.0K ohm
R11, R15, R22, R28	RESISTOR-CC, .50W 5% 1 ohm
R12, R14, R20, R21	RESISTOR-MF, .25W 1% 1.00K ohm
R13, R31	RESISTOR-MF, .25W 1% 20.0 ohm
R16, R23	RESISTOR-MF, .25W 1% 22.1K ohm
R18, R29, R37, R42	RESISTOR-MF, .25W 1% 475 ohm
R35, R36	RESISTOR-MF, .25W 1% 47.5 ohm
R38, R39, R40, R41	RESISTOR-MF, .25W 1% 39.2K ohm

NOTE: Individual parts listed are not available from Lincoln Electric.

NOTE: Lincoln Electric assumes no responsibility for liabilities resulting from board level troubleshooting. PC Board repairs will invalidate your factory warranty. **Individual Printed Circuit Board Components are not available from Lincoln Electric.** This information is provided for reference only. Lincoln Electric discourages board level troubleshooting and repair since it may compromise the quality of the design and may result in danger to the Machine Operator or Technician. Improper PC board repairs could result in damage to the machine.

SCHEMATIC - SWITCH PC BOARD (L10956)

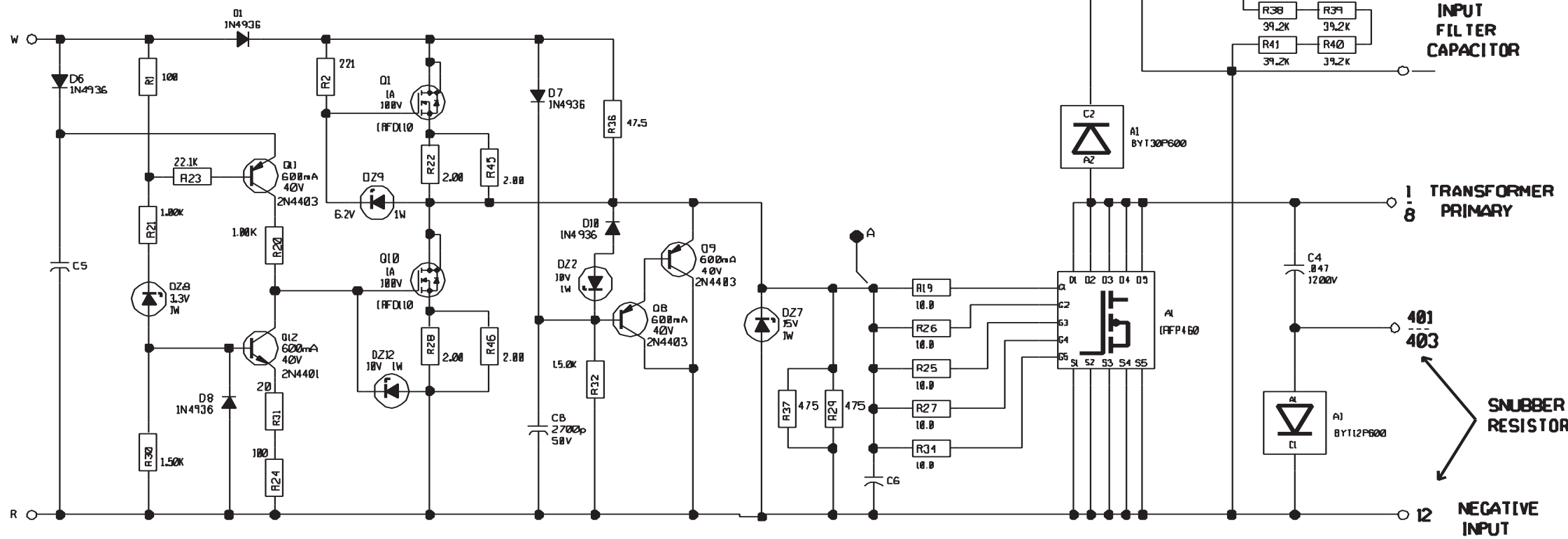
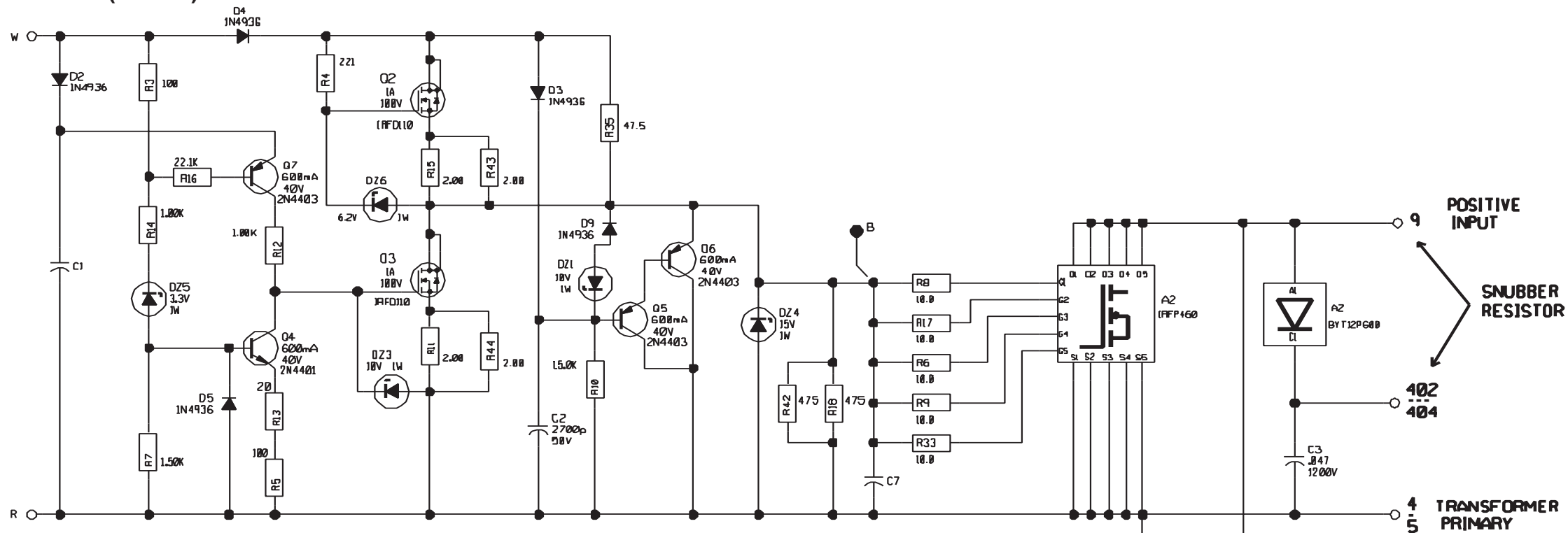

NOTE: This diagram is for reference only. It may not be accurate for all machines covered by this manual.

6-5-98a
L 10956

Return to Section TOC
Return to Master TOC
Return to Section TOC
Return to Master TOC
Return to Section TOC
Return to Master TOC
Return to Section TOC
Return to Master TOC

PC BOARD ASSEMBLY - SWITCH - (L10958-1)

Return to Section TOC
Return to Section TOC
Return to Section TOC
Return to Section TOC
Return to Section TOC
Return to Section TOC
Return to Section TOC
Return to Section TOC

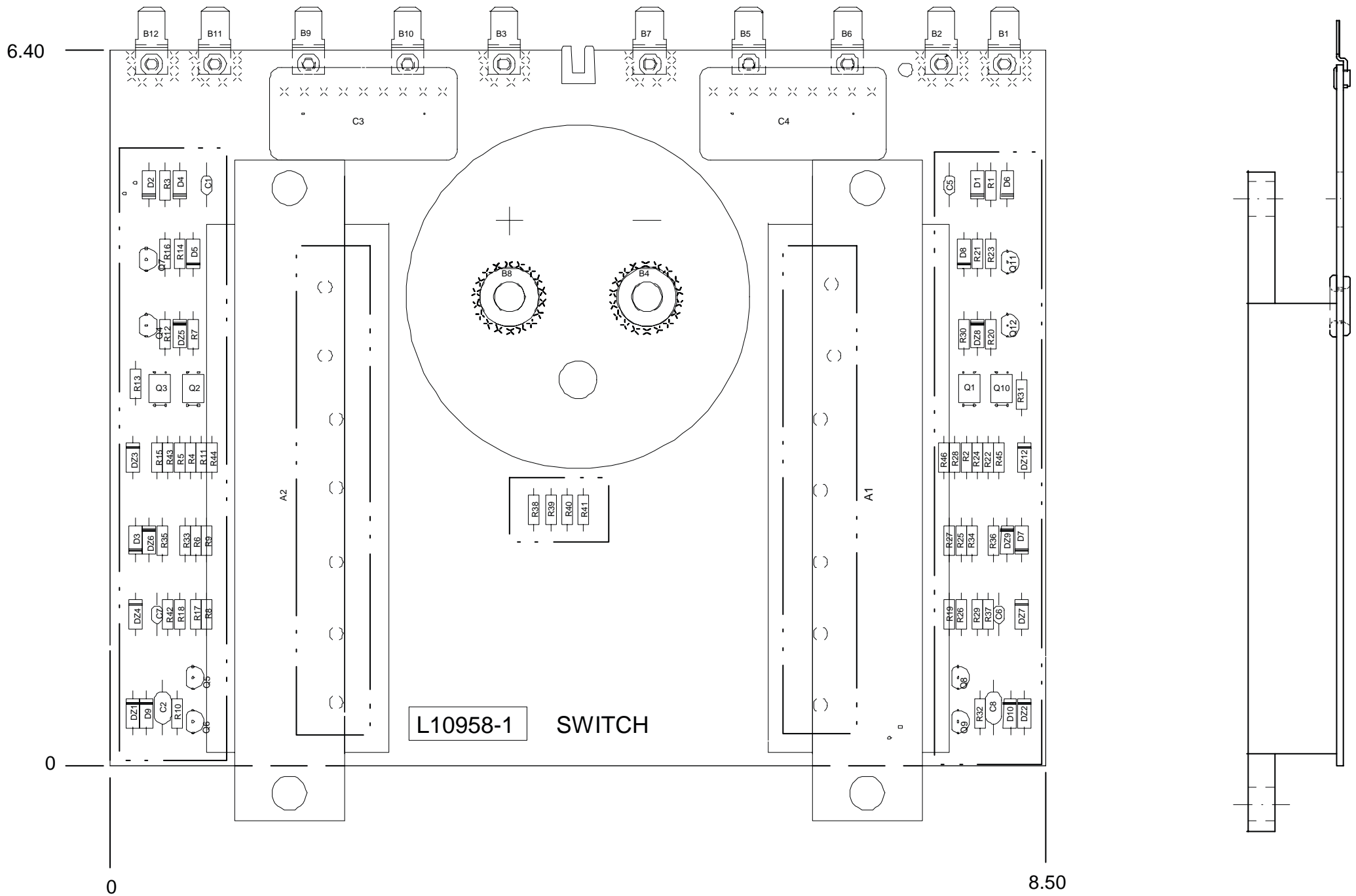

ITEM	REQ'D	PART NO.	IDENTIFICATION
C1,C5,C6,C7	4	S16668-5	.022/50
C2,C8	2	S16668-4	2700pF/50
C3,C4	2	S13490-112	.047/1200
D1,D2,D3,D4,D5,D6,D7,D8, D9,D10	10	T12705-34	1N4936
DZ1,DZ2,DZ3,DZ12	4	T12702-27	1N4740
DZ4,DZ7	2	T12702-29	1N4744A
DZ5,DZ8	2	T12702-53	1N4728A
DZ6,DZ9	2	T12702-40	1N4735
Q1,Q2,Q3,Q10	4	T12704-73	IC PKG MOSFET
Q4,Q12	2	T12704-68	2N4401
Q5,Q6,Q7,Q8,Q9,Q11	6	T12704-69	2N4403
R1,R3,R5,R24	4	S19400-1000	100 1/4W
R2,R4	2	S19400-2210	221 1/4W
R6,R8,R9,R17,R19,R25,R26 R27,R33,R34	10	S19400-10R0	10 1/4W
R7,R30	2	S19400-1501	1.5K 1/4W
R10,R32	2	S19400-1502	15K 1/4W
R11,R15,R22,R28,R43,R44 R45,R46	8	S19400-2R00	2.00 1/4W
R12,R14,R20,R21	4	S19400-1001	1K 1/4W
R13,R31	2	S19400-20R0	20 1/4W
R16,R23	2	S19400-2212	22.1K 1/4W
R18,R29,R37,R42	4	S19400-4750	475 1/4W
R35,R36	2	S19400-47R5	47.5 1/4W
R38,R39,R40,R41	4	S19400-3922	39.2K 1/4W

A
11/012002
L10958-1

NOTE: Lincoln Electric assumes no responsibility for liabilities resulting from board level troubleshooting. PC Board repairs will invalidate your factory warranty. **Individual Printed Circuit Board Components are not available from Lincoln Electric.** This information is provided for reference only. Lincoln Electric discourages board level troubleshooting and repair since it may compromise the quality of the design and may result in danger to the Machine Operator or Technician. Improper PC board repairs could result in damage to the machine.



PC BOARD ASSEMBLY - CONTROL - (G2527-3)

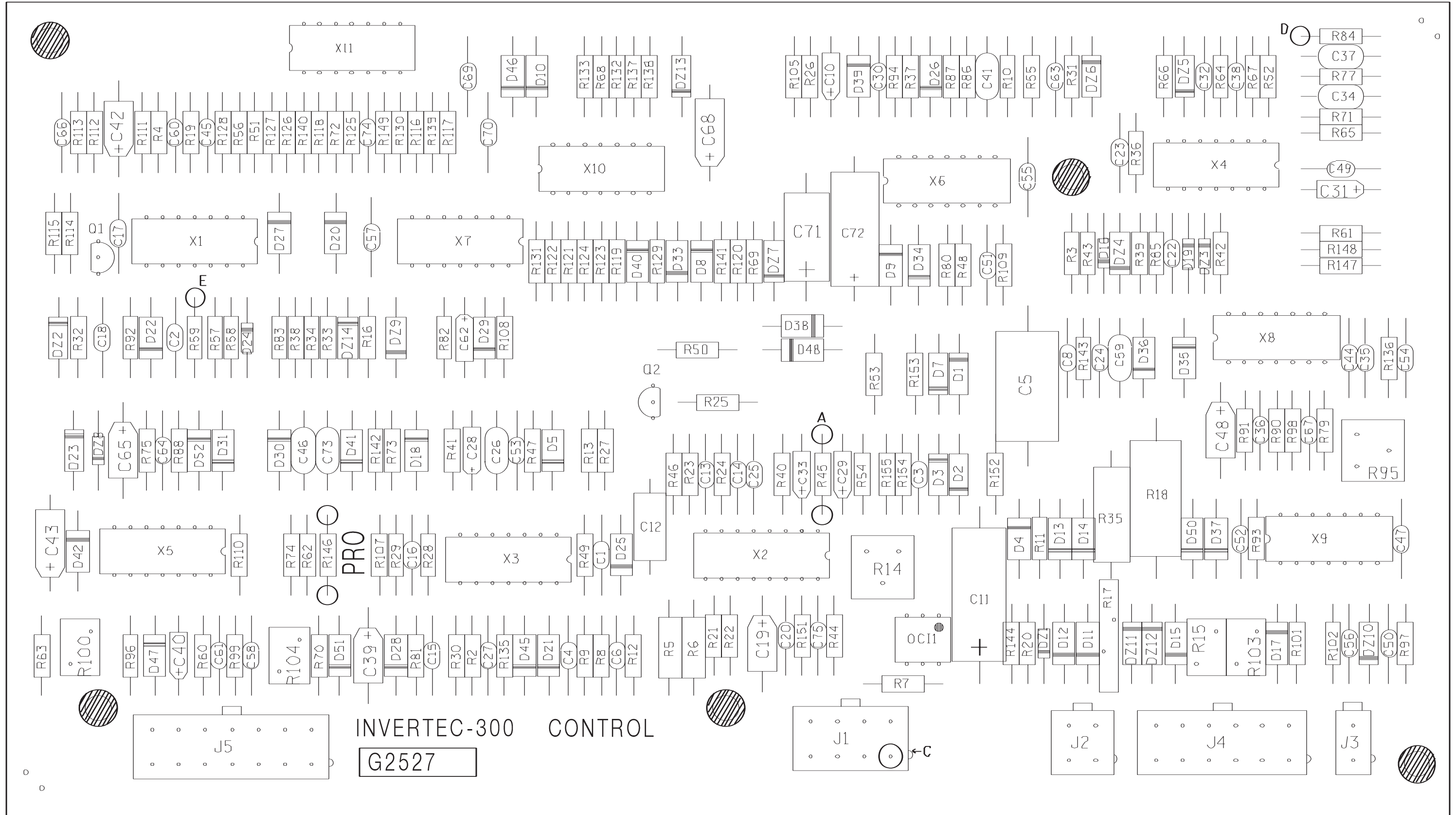

NOTE: Lincoln Electric assumes no responsibility for liabilities resulting from board level troubleshooting. PC Board repairs will invalidate your factory warranty. **Individual Printed Circuit Board Components are not available from Lincoln Electric.** This information is provided for reference only. Lincoln Electric discourages board level troubleshooting and repair since it may compromise the quality of the design and may result in danger to the Machine Operator or Technician. Improper PC board repairs could result in damage to the machine.

Return to Section TOC

Return to Master TOC

Return to Section TOC

Return to Master TOC

Return to Section TOC

Return to Master TOC

Return to Section TOC

Return to Master TOC

Item	Identification
C1, C2, C3, C6, C8, C14, C15, C16, C17, C20, C24, C27, C30, C32, C35, C36, C38, C44, C45, C47, C49, C50, C51, C52, C53, C54, C55, C56, C57, C58, C60, C61, C63, C64, C66, C67, C69, C70, C74	CAPACITOR, CEMO .022 50V 20%
C4, C23, C75	CAPACITOR, CEMO 150P 100V 5%
C5	CAPACITOR, PEMF 0.33 200V 10%
C10, C29, C33	CAPACITOR, TAEL 1.8 20V 10%
C11	CAPACITOR, ALEL 20 50V +75/-10%
C12	CAPACITOR, PFC .018 50V 2%
C13, C22, C25	CAPACITOR, CEMO 330P 100V 5%
C18	CAPACITOR, CEMO 4700P 50V 10%
C19, C39, C42, C48, C65	CAPACITOR, TAEL 4.7 35V 10%
C25	CAPACITOR, CEMO 47P 100V 5%
C26, C41, C46, C59, C73	CAPACITOR, CEMO 0.1 50V 10%
C28, C62	CAPACITOR, TAEL 1.0 35V 10%
C31, C40	CAPACITOR, TAEL 0.33 50V 10%
C34, C37	CAPACITOR, CEMO 2700P 50V 5%
C43, C68	CAPACITOR, TAEL 2.7 50V 10%
C71	CAPACITOR, TAEL 39 20V 10%
C72	CAPACITOR, TAEL 100 20V 10%
D1, D2, D3, D7	DIODE, AXLDS 1A 400V FR 1N4936
D4, D5, D8, D9, D10, D11, D12, D13, D14, D15, D17, D18, D20, D21, D22, D25, D26, D27, D28, D29, D30, D31, D33, D34, D35, D36, D37, D38, D39, D40, D41, D42, D45, D46, D47, D48, D50, D51, D52	DIODE, AXLDS 1A 400V
D16, D19, D24	DIODE, AXLDS 0.15A 75V 1N914
D23	DIODE, AXLDS 1A 30V Schottky
DZ1, DZ3, DZ8	DIODE, Zener 0.5W 3.0V 5% 1N5225B
DZ2, DZ7	DIODE, Zener 1W 10V 5% 1N4740A
DZ4, DZ6, DZ9, DZ10, DZ13, DZ14	DIODE, Zener 1W 5.1V 5% 1N4733A
DZ5	DIODE, Zener 1W 6.2V 5% 1N4735A
DZ11, DZ12	DIODE, Zener 1W 43V 5% 1N4755A

Item	Identification
J1	RECEPTACLE, Molex mini 8 pin
J2	RECEPTACLE, Molex mini 4 pin
J3	RECEPTACLE, Molex mini 2 pin
J4	RECEPTACLE, Molex mini 12 pin
J5	RECEPTACLE, Molex mini 14 pin
OC1	OPTOCOUPLER, Photo Q 70V CNY17-3
P1 (plugs into J1)	PLUG HOUSING, Molex 8 pin
P2 (plugs into J2)	PLUG HOUSING, Molex 4 pin
P3 (plugs into J3)	PLUG HOUSING, Molex 2 pin
P4 (plugs into J4)	PLUG HOUSING, Molex 12 pin
P5 (plugs into J5)	PLUG HOUSING, Molex 14 pin
Q1, Q2	TRANSISTOR-N, T226 0.5A 40V 2N4401
R2, R4, R8, R20, R23, R32, R38, R43, R45, R46, R51, R57, R64, R68, R87, R109, R125, R139, R141, R143, R151	RESISTOR-MF, .25W 1% 10.0K
R3, R10, R26, R42, R129	RESISTOR-MF, .25W 1% 475K
R5, R6	RESISTOR-CC, .50W 5% 1
R7, R9, R30, R47, R71, R11	RESISTOR-MF, .25W 1% 47.5K
R12, R25, R75, R98, R127, R133, R149	RESISTOR-MF, .25W 1% 267
R13, R34, R40, R48, R50, R60, R81, R94, R105, R114, R118, R123, R124	RESISTOR-MF, .25W 1% 22.1K
R14	TRIMMER-ST, .50W 10% 5K linear
R15, R100, R103, R104	THERMISTOR-PT, 56 ohms 9 oma
R16, R19, R28, R41, R113, R17	RESISTOR-MF, .25W 1% 332K
R18	THERMISTOR-PTC, .08-0.19 ohms 1.85A
R21, R73, R102, R119, R144	RESISTOR-CC, 2W 5% 680
R22, R70, R126, R132, R137, R140	RESISTOR-MF, .25W 1% 2.67K
R24, R130	RESISTOR-MF, .25W 1% 26.7K
R27, R37, R53, R55, R58, R92, R115, R136	RESISTOR-MF, .25W 1% 56.2K
R29	RESISTOR-MF, .25W 1% 33.2K
R31, R79, R88, R90, R93, R97, R99, R121, R135, R142	RESISTOR-MF, .25W 1% 392K
R33	RESISTOR-MF, 25W 1% 4.75K
R35	RESISTOR-MF, .25W 1% 3.32K
R36, R66, R85, R91, R110	RESISTOR-CC, 1W 5% 390
R39, R52, R72, R86	RESISTOR-MF, .25W 1% 150K
R44, R101	RESISTOR-MF, .25W 1% 221K
R49, R67, R80, R107, R54	RESISTOR-MF, 25W 1% 100
R54	RESISTOR-MF, .25W 1% 681K
R55	RESISTOR-MF, .25W 1% 16.2K
R56	RESISTOR-MF, .25W 1% 681K
R59	RESISTOR-MF, .25W 1% 16.2K
	RESISTOR-MF, .25W 1% 43.2K
	RESISTOR-MF, .25W 1% 82.5K

Item	Identification
R61, R147, R148	RESISTOR-MF, .25W 1% 10.0
R62	RESISTOR-MF, .25W 1% 8.25K
R63	RESISTOR-MF, .25W 1% 1.00K
R65, R77	RESISTOR-MF, .25W 1% 1.00K
R69	RESISTOR-MF, .25W 1% 475
R74	RESISTOR-MF, .25W 1% 18.2K
R82, R120, R128	RESISTOR-MF, .25W 1% 24.3K
R83	RESISTOR-MF, .25W 1% 301
R95	RESISTOR-MF, .25W 1% 267K
	TRIMMER-ST, .50W 10% 10K linear
R96	RESISTOR-MF, .25W1 825 %
R131	RESISTOR-MF, .25W 1% 68.1K
R146	RESISTOR-MF, .25W 1% 28.0K
R152, R153, R154, R155	RESISTOR-MF, .25W 1% 26.7K
TERMINALS (P1, P2, P3, P4, P5)	TERMINALS, Molex mini
X1, X3, X11	QUAD, IC-OP-AMP. gen. purpose 224J
X2	CONTROLLER, IC-PWM I-mode 3847
X4	QUAD, IC-OP-AMP high-perf 1014
X5, X6, X8, X9, X10	SWITCH, IC-CMOS analog quad 4066
X7	INVERTER, IC-CMOS Schmitt h ex 4584

NOTE: Individual parts listed are not available from Lincoln Electric.

NOTE: This diagram is for reference only. It may not be accurate for all machines covered by this manual. The wiring diagram specific to your code is pasted inside one of the enclosure panels of your machine.

SCHEMATIC - PROTECTION PC BOARD (M16097)

Return to Section TOC
Return to Master TOC

Return to Section TOC
Return to Master TOC

Return to Section TOC
Return to Master TOC

Return to Section TOC
Return to Master TOC

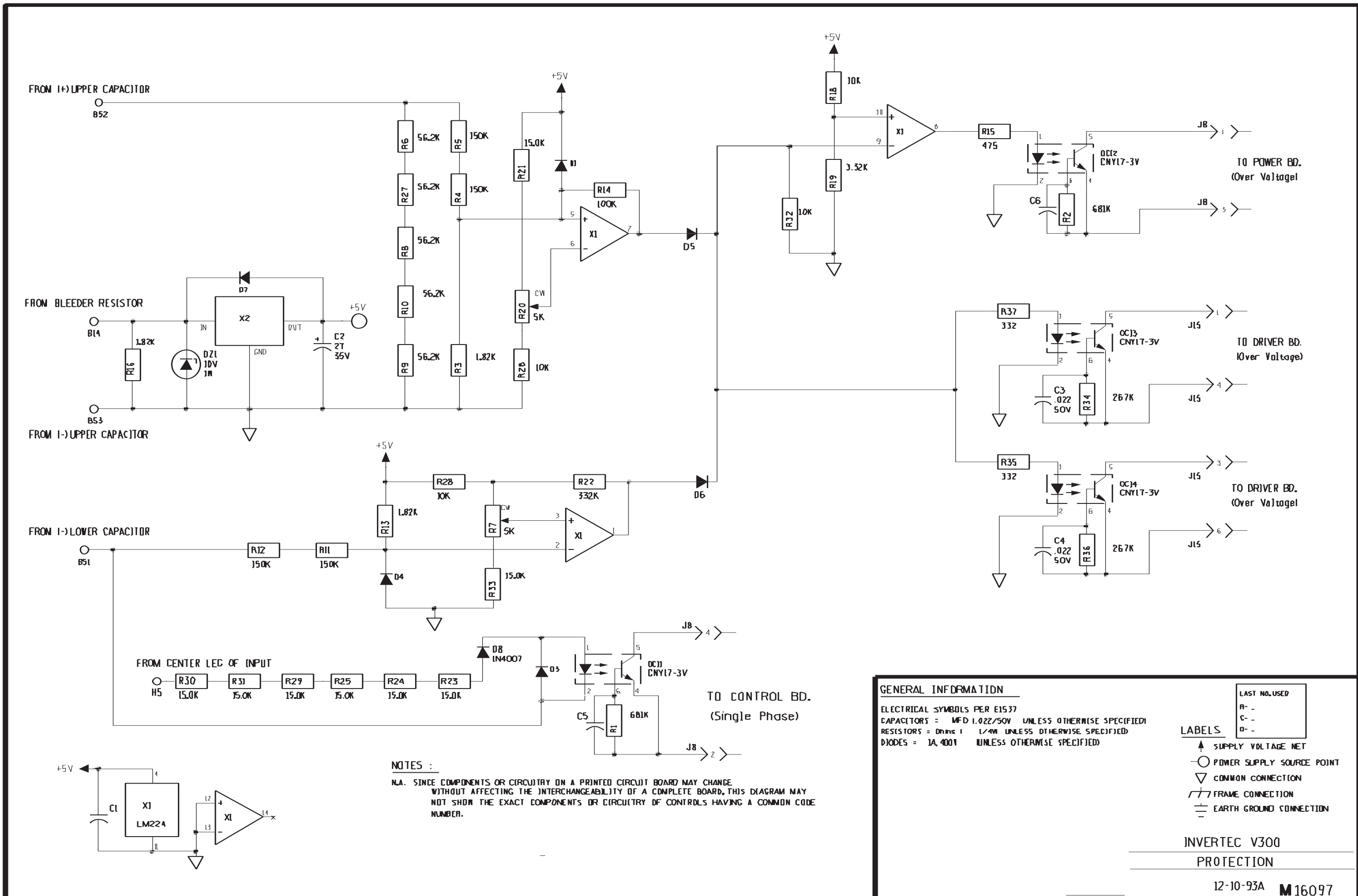

NOTES :
 N/A. SINCE COMPONENTS OR CIRCUITRY ON A PRINTED CIRCUIT BOARD MAY CHANGE WITHOUT AFFECTING THE INTERCHANGEABILITY OF A COMPLETE BOARD, THIS DIAGRAM MAY NOT SHOW THE EXACT COMPONENTS OR CIRCUITRY OF CONTROLS HAVING A COMMON CODE NUMBER.

GENERAL INFORMATION

ELECTRICAL SYMBOLS PER E1537
 CAPACITORS = MFD 0.022/50V UNLESS OTHERWISE SPECIFIED
 RESISTORS = Ohms 1/4W UNLESS OTHERWISE SPECIFIED
 DIODES = 1A, 400V UNLESS OTHERWISE SPECIFIED

LAST NO. USED	
R -	
C -	
D -	

LABELS

- ▲ SUPPLY VOLTAGE NET
- POWER SUPPLY SOURCE POINT
- ▽ COMMON CONNECTION
- FRAME CONNECTION
- ⊥ EARTH GROUND CONNECTION

INVERTEC V300
 PROTECTION
 12-10-93A M16097

NOTE: This diagram is for reference only. It may not be accurate for all machines covered by this manual.

PC BOARD ASSEMBLY - PROTECTION - (L7915-2)

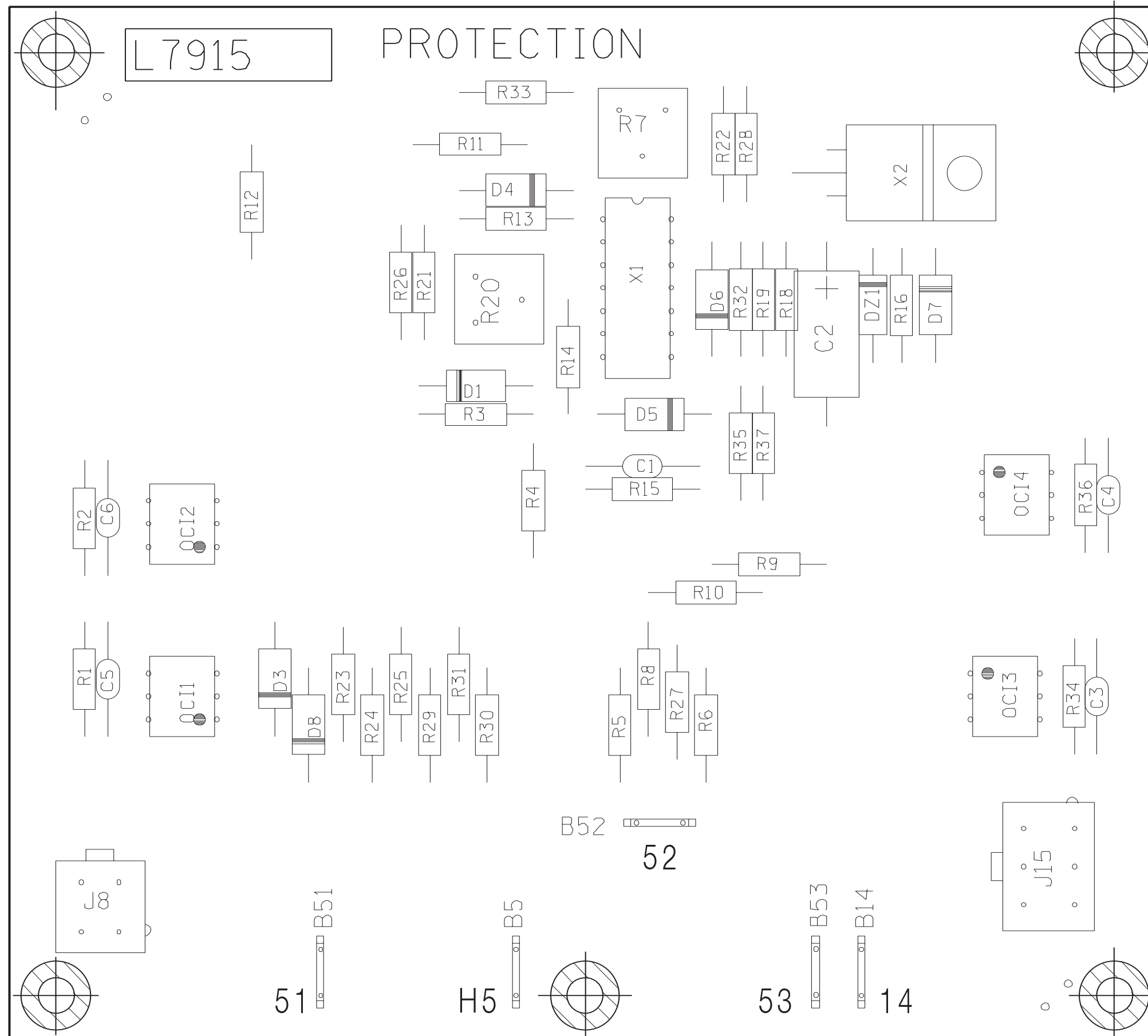

Item	Identification
B5, B14, B51, B52, B53	CONNECTOR, tab 1/4"
C1, C3, C4, C5, C6	CAPACITOR, ceramic
C2	CAPACITOR, tantlm etc. 27µf 35VDC
D1, D3, D4, D5, D6, D7	DIODE, 1A 400V
D8	DIODE, 1A 1000V
DZ1	DIODE, IN4740 Zener 10V 1W
J8	RECEPTACLE, Molex mini 4 pin
J15	RECEPTACLE, Molex mini 6 pin
OCI1, OCI2, OCI3, OCI4	OPTO, Isolator CNY17-3
P8 (plugs into J8)	PLUG HOUSING, Molex mini 4 pin
P15 (plugs into J15)	PLUG HOUSING, Molex mini 6 pin
R1, R2	RESISTOR, MF .25W 1% 681K ohm
R3, R13, R16	RESISTOR, MF .25W 1% 1.82K ohm.
R4, R5, R11, R12	RESISTOR, MF .25W 1% 150K ohm
R6, R8, R9, R10, R27	RESISTOR, MF .25W 1% 56.2K ohm
R7, R20	POTENTIOMETER, Cermet trimr .25W 1% 5K ohm
R14	RESISTOR, MF .25W 1% 100K ohm
R15	RESISTOR, MF .25W 1% 475 ohm
R18, R26, R28, R32	RESISTOR, MF .25W 1% 10K ohm
R19	RESISTOR, MF .25W 1% 3.32K ohm
R21, R23, R24, R25, R29, R30, R31, R33	RESISTOR, MF.25W 1% 15K ohm
R22	RESISTOR, MF .25W 1% 332K ohm
R34, R36	RESISTOR, MF .25W 1% 276K ohm
R35, R37	RESISTOR, MF .25W 1% 332 ohm
TERMINALS (P8, P15)	TERMINALS, Molex mini
X1	QUAD OP-AMP
X2	VOLTAGE REGULATOR, linear 7805 5VDC

NOTE: Individual parts listed are not available from Lincoln Electric.

Return to Section TOC
Return to Section TOC
Return to Section TOC
Return to Section TOC
Return to Section TOC
Return to Section TOC
Return to Section TOC
Return to Section TOC

SCHEMATIC - POWER PC BOARD (M16018)

Return to Section TOC
Return to Master TOC

Return to Section TOC
Return to Master TOC

Return to Section TOC
Return to Master TOC

Return to Section TOC
Return to Master TOC

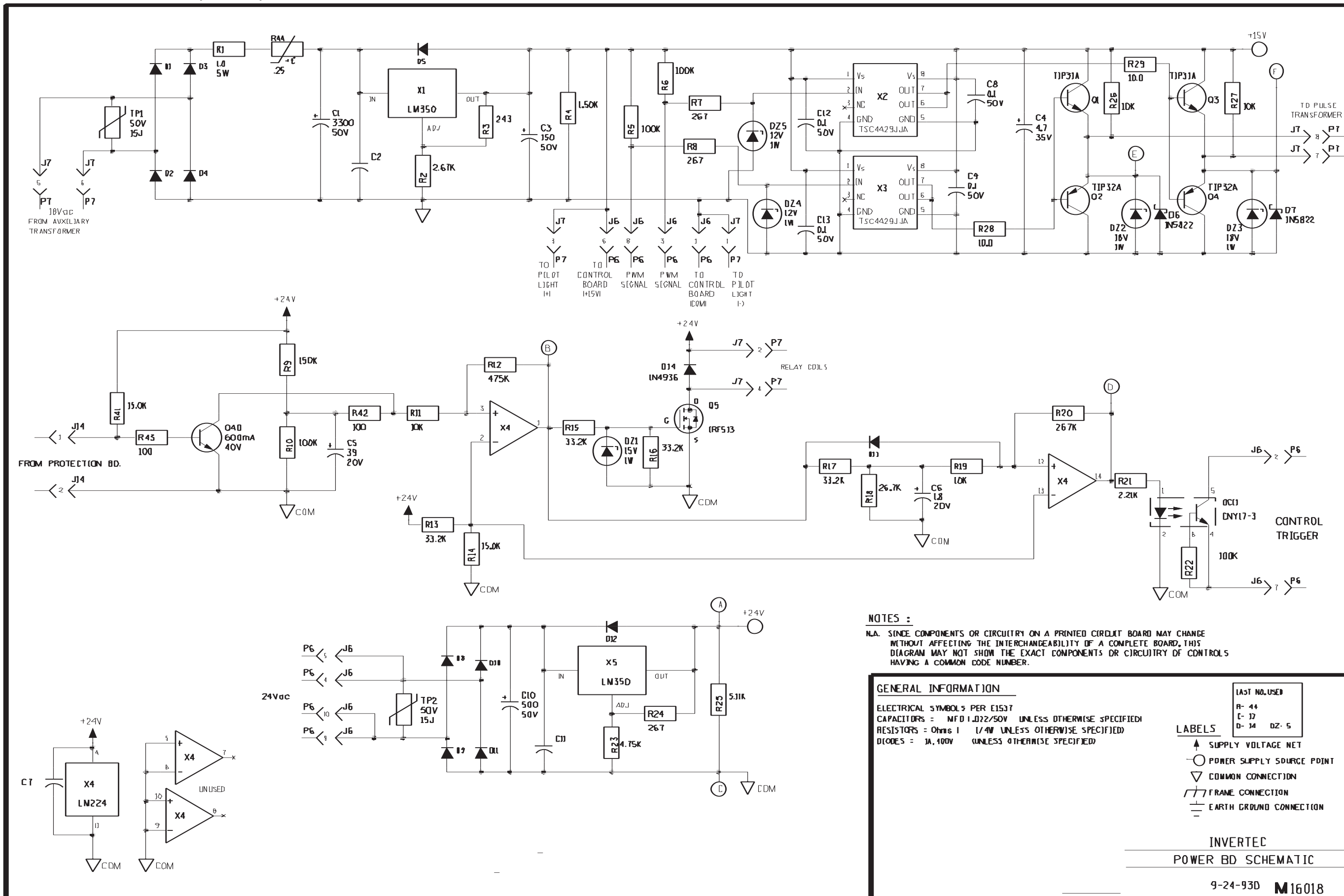

NOTE: This diagram is for reference only. It may not be accurate for all machines covered by this manual.

