

INVERTEC® V100-S & V130-S

For use with machines having Code Numbers: **V100-S 10461**
V130-S 10462

This manual covers equipment which is obsolete and no longer in production by The Lincoln Electric Co. Specifications and availability of optional features may have changed.

Safety Depends on You

Lincoln arc welding and cutting equipment is designed and built with safety in mind. However, your overall safety can be increased by proper installation ... and thoughtful operation on your part. **DO NOT INSTALL, OPERATE OR REPAIR THIS EQUIPMENT WITHOUT READING THIS MANUAL AND THE SAFETY PRECAUTIONS CONTAINED THROUGHOUT.** And, most importantly, think before you act and be careful.

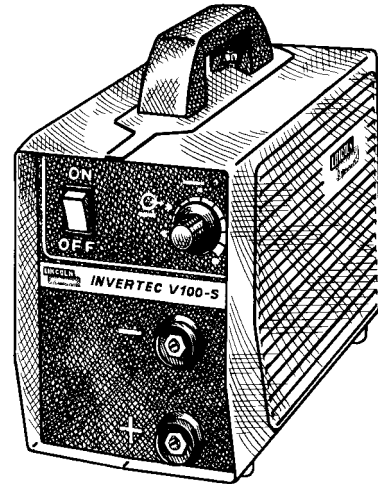
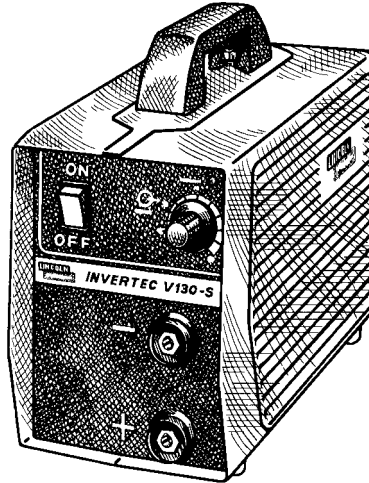

Date of Purchase: _____

Serial Number: _____

Code Number: _____

Model: _____

Where Purchased: _____

OPERATOR'S MANUAL

LINCOLN®
ELECTRIC

Copyright © 2002 Lincoln Global Inc.

• World's Leader in Welding and Cutting Products •

• Sales and Service through Subsidiaries and Distributors Worldwide •

Cleveland, Ohio 44117-1199 U.S.A. TEL: 216.481.8100 FAX: 216.486.1751 WEB SITE: www.lincolnelectric.com

⚠ WARNING

⚠ CALIFORNIA PROPOSITION 65 WARNINGS ⚠

Diesel engine exhaust and some of its constituents are known to the State of California to cause cancer, birth defects, and other reproductive harm.

The Above For Diesel Engines

The engine exhaust from this product contains chemicals known to the State of California to cause cancer, birth defects, or other reproductive harm.

The Above For Gasoline Engines

ARC WELDING CAN BE HAZARDOUS. PROTECT YOURSELF AND OTHERS FROM POSSIBLE SERIOUS INJURY OR DEATH. KEEP CHILDREN AWAY. PACEMAKER WEARERS SHOULD CONSULT WITH THEIR DOCTOR BEFORE OPERATING.

Read and understand the following safety highlights. For additional safety information, it is strongly recommended that you purchase a copy of "Safety in Welding & Cutting - ANSI Standard Z49.1" from the American Welding Society, P.O. Box 351040, Miami, Florida 33135 or CSA Standard W117.2-1974. A Free copy of "Arc Welding Safety" booklet E205 is available from the Lincoln Electric Company, 22801 St. Clair Avenue, Cleveland, Ohio 44117-1199.

BE SURE THAT ALL INSTALLATION, OPERATION, MAINTENANCE AND REPAIR PROCEDURES ARE PERFORMED ONLY BY QUALIFIED INDIVIDUALS.



FOR ENGINE powered equipment.

1.a. Turn the engine off before troubleshooting and maintenance work unless the maintenance work requires it to be running.



1.b. Operate engines in open, well-ventilated areas or vent the engine exhaust fumes outdoors.



1.c. Do not add the fuel near an open flame welding arc or when the engine is running. Stop the engine and allow it to cool before refueling to prevent spilled fuel from vaporizing on contact with hot engine parts and igniting. Do not spill fuel when filling tank. If fuel is spilled, wipe it up and do not start engine until fumes have been eliminated.



1.d. Keep all equipment safety guards, covers and devices in position and in good repair. Keep hands, hair, clothing and tools away from V-belts, gears, fans and all other moving parts when starting, operating or repairing equipment.

1.e. In some cases it may be necessary to remove safety guards to perform required maintenance. Remove guards only when necessary and replace them when the maintenance requiring their removal is complete. Always use the greatest care when working near moving parts.

1.f. Do not put your hands near the engine fan. Do not attempt to override the governor or idler by pushing on the throttle control rods while the engine is running.

1.g. To prevent accidentally starting gasoline engines while turning the engine or welding generator during maintenance work, disconnect the spark plug wires, distributor cap or magneto wire as appropriate.



1.h. To avoid scalding, do not remove the radiator pressure cap when the engine is hot.



ELECTRIC AND MAGNETIC FIELDS may be dangerous

2.a. Electric current flowing through any conductor causes localized Electric and Magnetic Fields (EMF). Welding current creates EMF fields around welding cables and welding machines

2.b. EMF fields may interfere with some pacemakers, and welders having a pacemaker should consult their physician before welding.

2.c. Exposure to EMF fields in welding may have other health effects which are now not known.

2.d. All welders should use the following procedures in order to minimize exposure to EMF fields from the welding circuit:

2.d.1. Route the electrode and work cables together - Secure them with tape when possible.

2.d.2. Never coil the electrode lead around your body.

2.d.3. Do not place your body between the electrode and work cables. If the electrode cable is on your right side, the work cable should also be on your right side.

2.d.4. Connect the work cable to the workpiece as close as possible to the area being welded.

2.d.5. Do not work next to welding power source.

Mar '95



ELECTRIC SHOCK can kill.

- 3.a. The electrode and work (or ground) circuits are electrically "hot" when the welder is on. Do not touch these "hot" parts with your bare skin or wet clothing. Wear dry, hole-free gloves to insulate hands.
- 3.b. Insulate yourself from work and ground using dry insulation. Make certain the insulation is large enough to cover your full area of physical contact with work and ground.

In addition to the normal safety precautions, if welding must be performed under electrically hazardous conditions (in damp locations or while wearing wet clothing; on metal structures such as floors, gratings or scaffolds; when in cramped positions such as sitting, kneeling or lying, if there is a high risk of unavoidable or accidental contact with the workpiece or ground) use the following equipment:

- Semiautomatic DC Constant Voltage (Wire) Welder.
- DC Manual (Stick) Welder.
- AC Welder with Reduced Voltage Control.

- 3.c. In semiautomatic or automatic wire welding, the electrode, electrode reel, welding head, nozzle or semiautomatic welding gun are also electrically "hot".
- 3.d. Always be sure the work cable makes a good electrical connection with the metal being welded. The connection should be as close as possible to the area being welded.
- 3.e. Ground the work or metal to be welded to a good electrical (earth) ground.
- 3.f. Maintain the electrode holder, work clamp, welding cable and welding machine in good, safe operating condition. Replace damaged insulation.
- 3.g. Never dip the electrode in water for cooling.
- 3.h. Never simultaneously touch electrically "hot" parts of electrode holders connected to two welders because voltage between the two can be the total of the open circuit voltage of both welders.
- 3.i. When working above floor level, use a safety belt to protect yourself from a fall should you get a shock.
- 3.j. Also see Items 6.c. and 8.



ARC RAYS can burn.

- 4.a. Use a shield with the proper filter and cover plates to protect your eyes from sparks and the rays of the arc when welding or observing open arc welding. Headshield and filter lens should conform to ANSI Z87.1 standards.
- 4.b. Use suitable clothing made from durable flame-resistant material to protect your skin and that of your helpers from the arc rays.
- 4.c. Protect other nearby personnel with suitable, non-flammable screening and/or warn them not to watch the arc nor expose themselves to the arc rays or to hot spatter or metal.



FUMES AND GASES can be dangerous.

- 5.a. Welding may produce fumes and gases hazardous to health. Avoid breathing these fumes and gases. When welding, keep your head out of the fume. Use enough ventilation and/or exhaust at the arc to keep fumes and gases away from the breathing zone. **When welding with electrodes which require special ventilation such as stainless or hard facing (see instructions on container or MSDS) or on lead or cadmium plated steel and other metals or coatings which produce highly toxic fumes, keep exposure as low as possible and below Threshold Limit Values (TLV) using local exhaust or mechanical ventilation. In confined spaces or in some circumstances, outdoors, a respirator may be required. Additional precautions are also required when welding on galvanized steel.**
- 5.b. Do not weld in locations near chlorinated hydrocarbon vapors coming from degreasing, cleaning or spraying operations. The heat and rays of the arc can react with solvent vapors to form phosgene, a highly toxic gas, and other irritating products.
- 5.c. Shielding gases used for arc welding can displace air and cause injury or death. Always use enough ventilation, especially in confined areas, to insure breathing air is safe.
- 5.d. Read and understand the manufacturer's instructions for this equipment and the consumables to be used, including the material safety data sheet (MSDS) and follow your employer's safety practices. MSDS forms are available from your welding distributor or from the manufacturer.
- 5.e. Also see item 1.b.

Mar '95

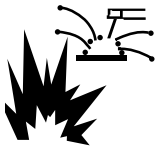

WELDING SPARKS can cause fire or explosion.

6.a. Remove fire hazards from the welding area. If this is not possible, cover them to prevent the welding sparks from starting a fire.

Remember that welding sparks and hot materials from welding can easily go through small cracks and openings to adjacent areas. Avoid welding near hydraulic lines. Have a fire extinguisher readily available.

- 6.b. Where compressed gases are to be used at the job site, special precautions should be used to prevent hazardous situations. Refer to "Safety in Welding and Cutting" (ANSI Standard Z49.1) and the operating information for the equipment being used.
- 6.c. When not welding, make certain no part of the electrode circuit is touching the work or ground. Accidental contact can cause overheating and create a fire hazard.
- 6.d. Do not heat, cut or weld tanks, drums or containers until the proper steps have been taken to insure that such procedures will not cause flammable or toxic vapors from substances inside. They can cause an explosion even though they have been "cleaned". For information, purchase "Recommended Safe Practices for the Preparation for Welding and Cutting of Containers and Piping That Have Held Hazardous Substances", AWS F4.1 from the American Welding Society (see address above).
- 6.e. Vent hollow castings or containers before heating, cutting or welding. They may explode.
- 6.f. Sparks and spatter are thrown from the welding arc. Wear oil free protective garments such as leather gloves, heavy shirt, cuffless trousers, high shoes and a cap over your hair. Wear ear plugs when welding out of position or in confined places. Always wear safety glasses with side shields when in a welding area.
- 6.g. Connect the work cable to the work as close to the welding area as practical. Work cables connected to the building framework or other locations away from the welding area increase the possibility of the welding current passing through lifting chains, crane cables or other alternate circuits. This can create fire hazards or overheat lifting chains or cables until they fail.
- 6.h. Also see item 1.c.

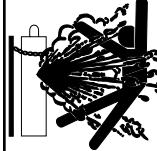

CYLINDER may explode if damaged.

7.a. Use only compressed gas cylinders containing the correct shielding gas for the process used and properly operating regulators designed for the gas and pressure used. All hoses, fittings, etc. should be suitable for the application and maintained in good condition.

- 7.b. Always keep cylinders in an upright position securely chained to an undercarriage or fixed support.
- 7.c. Cylinders should be located:
 - Away from areas where they may be struck or subjected to physical damage.
 - A safe distance from arc welding or cutting operations and any other source of heat, sparks, or flame.
- 7.d. Never allow the electrode, electrode holder or any other electrically "hot" parts to touch a cylinder.
- 7.e. Keep your head and face away from the cylinder valve outlet when opening the cylinder valve.
- 7.f. Valve protection caps should always be in place and hand tight except when the cylinder is in use or connected for use.
- 7.g. Read and follow the instructions on compressed gas cylinders, associated equipment, and CGA publication P-1, "Precautions for Safe Handling of Compressed Gases in Cylinders," available from the Compressed Gas Association 1235 Jefferson Davis Highway, Arlington, VA 22202.



FOR ELECTRICALLY powered equipment.

- 8.a. Turn off input power using the disconnect switch at the fuse box before working on the equipment.
- 8.b. Install equipment in accordance with the U.S. National Electrical Code, all local codes and the manufacturer's recommendations.
- 8.c. Ground the equipment in accordance with the U.S. National Electrical Code and the manufacturer's recommendations.

Mar '95

PRÉCAUTIONS DE SÛRETÉ

Pour votre propre protection lire et observer toutes les instructions et les précautions de sûreté spécifiques qui paraissent dans ce manuel aussi bien que les précautions de sûreté générales suivantes:

Sûreté Pour Soudage A L'Arc

1. Protégez-vous contre la secousse électrique:
 - a. Les circuits à l'électrode et à la pièce sont sous tension quand la machine à souder est en marche. Eviter toujours tout contact entre les parties sous tension et la peau nue ou les vêtements mouillés. Porter des gants secs et sans trous pour isoler les mains.
 - b. Faire très attention de bien s'isoler de la masse quand on soude dans des endroits humides, ou sur un plancher métallique ou des grilles métalliques, principalement dans les positions assis ou couché pour lesquelles une grande partie du corps peut être en contact avec la masse.
 - c. Maintenir le porte-électrode, la pince de masse, le câble de soudage et la machine à souder en bon et sûr état de fonctionnement.
 - d. Ne jamais plonger le porte-électrode dans l'eau pour le refroidir.
 - e. Ne jamais toucher simultanément les parties sous tension des porte-électrodes connectés à deux machines à souder parce que la tension entre les deux pinces peut être le total de la tension à vide des deux machines.
 - f. Si on utilise la machine à souder comme une source de courant pour soudage semi-automatique, ces précautions pour le porte-électrode s'appliquent aussi au pistolet de soudage.
2. Dans le cas de travail au dessus du niveau du sol, se protéger contre les chutes dans le cas où on reçoit un choc. Ne jamais enrouler le câble-électrode autour de n'importe quelle partie du corps.
3. Un coup d'arc peut être plus sévère qu'un coup de soleil, donc:
 - a. Utiliser un bon masque avec un verre filtrant approprié ainsi qu'un verre blanc afin de se protéger les yeux du rayonnement de l'arc et des projections quand on soude ou quand on regarde l'arc.
 - b. Porter des vêtements convenables afin de protéger la peau de soudeur et des aides contre le rayonnement de l'arc.
 - c. Protéger l'autre personnel travaillant à proximité au soudage à l'aide d'écrans appropriés et non-inflammables.
4. Des gouttes de laitier en fusion sont émises de l'arc de soudage. Se protéger avec des vêtements de protection libres de l'huile, tels que les gants en cuir, chemise épaisse, pantalons sans revers, et chaussures montantes.
5. Toujours porter des lunettes de sécurité dans la zone de soudage. Utiliser des lunettes avec écrans latéraux dans les

zones où l'on pique le laitier.

6. Eloigner les matériaux inflammables ou les recouvrir afin de prévenir tout risque d'incendie dû aux étincelles.
7. Quand on ne soude pas, poser la pince à un endroit isolé de la masse. Un court-circuit accidentel peut provoquer un échauffement et un risque d'incendie.
8. S'assurer que la masse est connectée le plus près possible de la zone de travail qu'il est pratique de le faire. Si on place la masse sur la charpente de la construction ou d'autres endroits éloignés de la zone de travail, on augmente le risque de voir passer le courant de soudage par les chaînes de levage, câbles de grue, ou autres circuits. Cela peut provoquer des risques d'incendie ou d'échauffement des chaînes et des câbles jusqu'à ce qu'ils se rompent.
9. Assurer une ventilation suffisante dans la zone de soudage. Ceci est particulièrement important pour le soudage de tôles galvanisées plombées, ou cadmiées ou tout autre métal qui produit des fumées toxiques.
10. Ne pas souder en présence de vapeurs de chlore provenant d'opérations de dégraissage, nettoyage ou pistologie. La chaleur ou les rayons de l'arc peuvent réagir avec les vapeurs du solvant pour produire du phosgène (gas fortement toxique) ou autres produits irritants.
11. Pour obtenir de plus amples renseignements sur la sûreté, voir le code "Code for safety in welding and cutting" CSA Standard W 117.2-1974.

PRÉCAUTIONS DE SÛRETÉ POUR LES MACHINES À SOUDER À TRANSFORMATEUR ET À REDRESSEUR

1. Relier à la terre le châssis du poste conformément au code de l'électricité et aux recommandations du fabricant. Le dispositif de montage ou la pièce à souder doit être branché à une bonne mise à la terre.
2. Autant que possible, l'installation et l'entretien du poste seront effectués par un électricien qualifié.
3. Avant de faire des travaux à l'intérieur de poste, la débrancher à l'interrupteur à la boîte de fusibles.
4. Garder tous les couvercles et dispositifs de sûreté à leur place.

Mar. '93

Thank You — for selecting a **QUALITY** product by Lincoln Electric. We want you to take pride in operating this Lincoln Electric Company product •• as much pride as we have in bringing this product to you!

Please Examine Carton and Equipment For Damage Immediately

When this equipment is shipped, title passes to the purchaser upon receipt by the carrier. Consequently, Claims for material damaged in shipment must be made by the purchaser against the transportation company at the time the shipment is received.

Please record your equipment identification information below for future reference. This information can be found on your machine nameplate.

Model Name & Number _____

Code & Serial Number _____

Date of Purchase _____

Whenever you request replacement parts for or information on this equipment always supply the information you have recorded above.

Read this Operators Manual completely before attempting to use this equipment. Save this manual and keep it handy for quick reference. Pay particular attention to the safety instructions we have provided for your protection. The level of seriousness to be applied to each is explained below:

⚠ WARNING

This statement appears where the information **must** be followed **exactly** to avoid **serious personal injury** or **loss of life**.

⚠ CAUTION

This statement appears where the information **must** be followed to avoid **minor personal injury** or **damage to this equipment**.

Installation.....	Section A
Technical Specifications V100-S.....	A-1
Technical Specifications V130-S.....	A-2
Safety Precautions.....	A-3
Select Suitable Location.....	A-3
Stacking.....	A-3
Tilting.....	A-3
High Frequency Precautions.....	A-3
Input Supply Connections.....	A-3
Input Fuse and Supply Wire.....	A-3
Output Connections.....	A-3
Output Connections.....	A-4
Output Connection for Stick Welding.....	A-4
Output and Gas Connection for TIG Welding.....	A-4
Quick Disconnect Plug.....	A-4
<hr/>	
Operation.....	Section B
Safety Instructions.....	B-1
General Description.....	B-1
Operational Features.....	B-1
Welding Capability.....	B-1
Limitations.....	B-1
Controls and Settings.....	B-2
Constant Current Processes.....	B-3
Manual Arc Welding (Stick).....	B-3
TIG Welding.....	B-3
Overload Protection.....	B-3
Thermal Protection.....	B-3
<hr/>	
Accessories.....	Section C
Options / Accessories.....	C-1
<hr/>	
Maintenance.....	Section D
Safety Precautions.....	D-1
Input Filter Capacitor Discharge Procedure.....	D-1
Routine Maintenance.....	D-1
<hr/>	
Troubleshooting.....	Section E
PC Board Troubleshooting Procedures.....	E-1
Troubleshooting Chart.....	E-2
<hr/>	
Diagrams.....	Section F
Wiring Diagram V100-S.....	F-1
Wiring Diagram V130-S.....	F-2
<hr/>	
Parts Lists.....	Appendix
V100-S.....	P-304
V130-S.....	P-305

Technical Specifications - Invertec V100-S

INPUT					
SINGLE PHASE					
INPUT Voltage⁽²⁾		Input Current at Rated Output		Hertz	
115V		32A @ 100A OUTPUT 25A @ 85A OUTPUT 20A @ 70A OUTPUT		50/60 Hz	
RATED OUTPUT					
Duty Cycle⁽¹⁾		Amps		Volts at Rated Amps	
15% Duty Cycle		100		24	
20% Duty Cycle		85 (20 Amp Circuit)		23.5	
20% Duty Cycle		70 (15 Amp Circuit)		23	
OUTPUT					
Welding Current Range			Maximum Open Circuit Voltage		
8-100 Amps			67 VDC		
RECOMMENDED INPUT CABLE AND FUSE SIZES					
OUTPUT CURRENT	FUSE (SUPERLAG) OR BREAKER SIZE	INPUT CURRENT RATING	POWER CORD	EXTENSION CORD (up to 50 feet)	EXTENSION CORD (more than 50 feet)
100A	30A	32A	30 Amp, 125V, Three-prong plug (NEMA Type 5-30P)	Three Conductor #10 AWG (5.2 mm ²) or larger	Three Conductor #8 AWG (8.2 mm ²) or larger
85A	25A	25A	20Amp, 125V, Three-prong plug (NEMA Type 5-20P)	Three Conductor #12 AWG (3.3 mm ²) or larger	Three Conductor #10 AWG (5.2 mm ²) or larger
70A	20A	20A	15 Amp, 125V, Three-prong plug (NEMA Type 5-15P)	Three Conductor #14 AWG (2.0 mm ²) or larger	Three Conductor #12 AWG (3.3 mm ²) or larger
PHYSICAL DIMENSIONS					
Height		Width		Depth	
10.0 in.		5.4 in.		13.8 in.	
254 mm		138 mm		351 mm	
Weight					
11.0 lbs.					
5.0 Kg					
OPERATING TEMPERATURE			STORAGE TEMPERATURE		
-20°C to +40°C			-25°C to +55°C		

(1) Based on a 10 min. period.

(2) Input voltage must be within ±10% of rated value.

Technical Specifications - Invertec V130-S

INPUT					
SINGLE PHASE					
INPUT Voltage⁽²⁾		Input Current at Rated Output		Hertz	
230V		25A @ 130A OUTPUT 19A @ 105A OUTPUT 16A @ 90A OUTPUT		50/60 Hz	
RATED OUTPUT					
Duty Cycle⁽¹⁾		Amps		Volts at Rated Amps	
20% Duty Cycle		130		25.5	
60% Duty Cycle		105		24.5	
100% Duty Cycle		90		24	
OUTPUT					
Welding Current Range			Maximum Open Circuit Voltage		
3-130 Amps			67 VDC		
RECOMMENDED INPUT CABLE AND FUSE SIZES					
OUTPUT CURRENT	FUSE (SUPERLAG) OR BREAKER SIZE	INPUT CURRENT RATING	POWER CORD	EXTENSION CORD (up to 50 feet)	EXTENSION CORD (more than 50 feet)
130A	40A	25A	50 Amp, 250V, Three-prong plug (NEMA Type 6-50P)	Three Conductor #6 AWG (13.0 mm ²) or larger	Three Conductor #4 AWG (20.7 mm ²) or larger
PHYSICAL DIMENSIONS					
Height		Width		Depth	
10.0 in.		5.4 in.		13.8 in.	
254 mm		138 mm		351 mm	
Weight			Weight		
11.0 lbs.			5.0 Kg		
OPERATING TEMPERATURE			STORAGE TEMPERATURE		
-20°C to +40°C			-25°C to +55°C		

(1) Based on a 10 min. period.

(2) Input voltage must be within ±10% of rated value.

Read this entire installation section before you start installation.

SAFETY PRECAUTIONS



WARNING



ELECTRIC SHOCK can kill.

- Have an electrician install and service this equipment.
- Turn the input power off at the fuse box, disconnect supply lines and allow machine to sit for five minutes minimum to allow the power capacitors to discharge before working inside this equipment.
- Do not touch electrically hot parts.

SELECT SUITABLE LOCATION

The Invertec will operate in harsh environments. Even so, it is important that simple preventative measures are followed in order to assure long life and reliable operation.

- The machine must be located where there is free circulation of clean air such that air movement in the sides and out the sides will not be restricted.
- Dirt and dust that can be drawn into the machine should be kept to a minimum. Failure to observe these precautions can result in excessive operating temperatures and nuisance shutdown.
- The machines have a protection rating of IP23. Keep the machines dry when possible. Do not place them on wet ground or in puddles.

STACKING

These Invertecs cannot be stacked.

TILTING

Place the machine directly on a secure, level surface. The machine may topple over if this procedure is not followed.

HIGH FREQUENCY PRECAUTIONS

If possible locate the Invertec away from radio controlled machinery. The normal operation of the Invertec may adversely affect the operation of RF controlled equipment, which may result in bodily injury or damage to the equipment.

INPUT SUPPLY CONNECTIONS

Be sure the voltage, phase and frequency of the input power is as specified on the rating plate, located on the rear of the machine.

Both models are supplied with an input supply cable with a molded plug. The V130-S has a 50A molded plug and the V100-S is shipped with a molded 15A plug and an additional 20A plug that can replace the 15A plug when necessary to achieve 85A output. To install the supplied 20A plug: Connect the white (neutral) wire under terminal clamp with silver screw, and black (hot) wire under terminal clamp with brass screw. Connect green wire under terminal clamp with green screw. Tighten terminal wire clamp screws securely. **WARNING:** Failure to wire as instructed may cause personal injury or damage to equipment. To be installed or checked by an electrician or qualified person only. In order to achieve full output from the V100-S it is necessary to attach a 30A plug (NEMA 5-30P).

INPUT FUSE AND SUPPLY WIRE

Refer to the *Technical Specifications* pages at the beginning of this chapter for the proper fuse sizes and supply cable sizes.

- Fuse the input circuit with recommended super lag fuses or delay type circuit breakers.
- Install the proper fuse in the fuse holder in the main disconnect panel.

OUTPUT CONNECTIONS

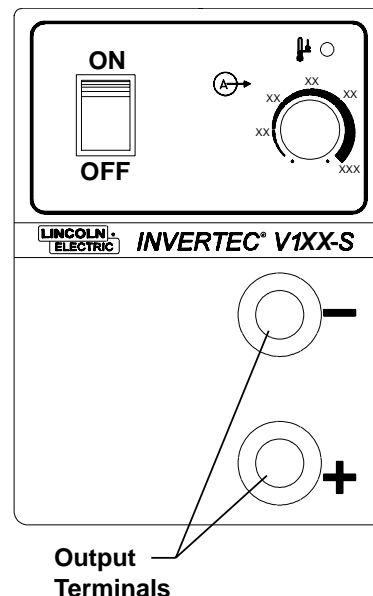

FIGURE A.1 OUTPUT CONNECTIONS

OUTPUT CONNECTIONS

Refer to Figure A.1 for the location of the output terminals. A quick-disconnect system using Twist-Mate™ cable plugs is used for the welding cable connections. The electrode and work cables included with the machine have these plugs. An extra plug is also included with the machine if TIG welding is desired. Refer to the relevant instructions below for more information on connecting the machine for either of these two welding processes.

OUTPUT CONNECTION FOR STICK WELDING

First determine the proper electrode polarity for the electrode to be used. Consult the electrode data for this information. Then connect the output cables to the output terminals corresponding to this polarity. For instance, for DC(+) welding, connect the electrode cable (which is connected to the electrode holder) to the "+" output terminal and the work cable (which is connected to the work clamp) to the "-" output terminal. Insert the connector with the key lining up with the keyway, and rotate approximately 1/4 turn clockwise; until the connection is snug. Do not over tighten.

OUTPUT AND GAS CONNECTION FOR TIG WELDING

These units do not include a TIG torch, but one may be purchased separately and used with these units to do TIG (GTAW) welding. The Lincoln LA-9 (K859-3 or K859-7 only; no gas valve) and LA-17V (K860-11 or K860-15 only; includes gas valve) are recommended for use with these machines for this purpose; however, any similar TIG torch can be used.

If the torch to be used does not have a mating Twist-Mate plug on the end of the power cable, the power cable must be modified to include one. The LA-9 and LA-17V fall in this category. Cut off the lug on the end of the power cable and attach the extra Twist Mate plug included with the machine to the power cable per the instructions following under **QUICK DISCONNECT PLUG**.

Next connect the torch cable to the appropriate output terminal on the machine. Most TIG welding is done with DC(-) polarity. For this polarity, connect the torch plug to the "-" output terminal on the machine. Insert the connector with the key lining up with the keyway, and rotate approximately 1/4 turn clockwise; until the connection is snug. Do not over tighten. Connect the work cable (which is connected to the work clamp) to the "+" output terminal in the same way. Finally, connect the gas hose to the gas regulator on the cylinder of gas to be used.

The machine can easily be switched between stick and TIG welding at any time by simply swapping the stick (electrode) and TIG (torch) cables, and reversing the connection polarity if required.

QUICK DISCONNECT PLUG

A quick disconnect system is used for the welding cable connections. The electrode and work cables have the plug attached, on both machines an additional plug is supplied if TIG welding is to be done. The welding plug included with the machine is designed to accept a welding cable size of #6 to #4 (10mm² to 25mm²).

1. Cut off welding cable lug, if present.
2. Remove .75 in. (19mm) of welding cable insulation.
3. Slide rubber boot onto cable end. The boot end may be trimmed to match the cable diameter. Use soap or other nonpetroleum-based lubricant to help slide the boot over the cable, if needed.

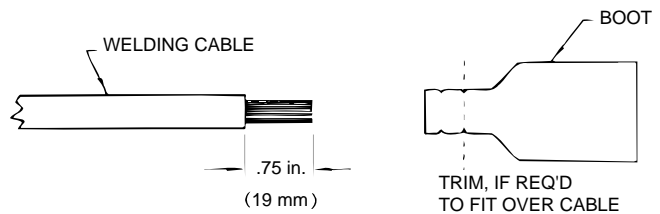

4. Cut 45-50% of the copper strands back 1/4" (6 mm).

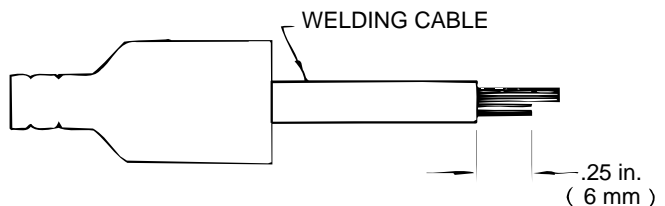

5. Fold copper strands over cut strands and insert into ferrule.

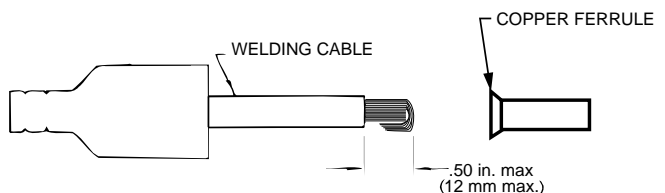

6. Slide the copper ferrule into the brass plug.
7. Tighten set screw to collapse copper tube. Screw must apply pressure against welding cable. The top of the set screw will be well below the surface of the brass plug after tightening.

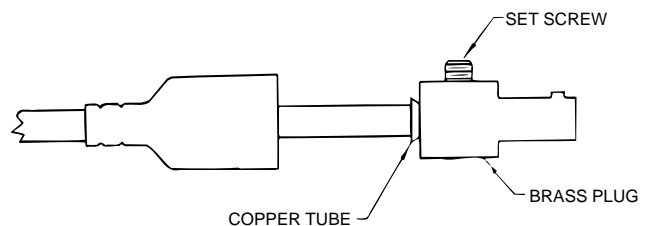

8. Slide rubber boot over brass plug. The rubber boot must be positioned to completely cover all electrical surfaces after the plug is locked into the receptacle.

Read and understand this entire section before operating your machine.

SAFETY INSTRUCTIONS

WARNING



ELECTRIC SHOCK can kill.

- Do not touch electrically live parts such as output terminals or internal wiring.
- Insulate yourself from the work and ground.
- Always wear dry insulating gloves.



FUMES AND GASES can be dangerous.

- Keep your head out of fumes.
- Use ventilation or exhaust to remove fumes from breathing zone.



WELDING, CUTTING and GOUGING SPARKS can cause fire or explosion

- Keep flammable material away.
- Do not weld, cut or gouge on containers that have held combustibles.



ARC RAYS can burn.

- Wear eye, ear and body protection.

Only qualified personnel should operate this equipment. Observe all safety information throughout this manual.

GENERAL DESCRIPTION

The Invertec V100-S is a light industrial 100 amp arc welding power source and the V130-S is a light industrial 130 amp arc welding power source both of which utilize single phase input power, to produce constant current output. The welding response of these Invertecs has been optimized for stick (SMAW) and TIG (GTAW). Both units are perfect for light industrial applications where portability is important.

OPERATIONAL FEATURES

The Invertecs provide continuous total range output current adjustment. Additionally, a “hot start” system has been built into the welding current control, and provides a higher striking current to assist ignition of the arc.

WELDING CAPABILITY

The Invertec V100-S is rated at 100 amps, 15% duty cycle (based on a 10 minute cycle). It is also rated at 85 amps, 20% duty cycle, and 70 amps, 20% duty cycle. The Invertec V130-S is rated at 130 amps, 20% duty cycle (based on a 10 minute cycle). It is also rated at 105 amps, 60% duty cycle, and 90 amps, 100% duty cycle.

LIMITATIONS

The V100-S and V130-S are not recommended for pipe thawing.

The V100-S and V130-S should not be powered from the auxiliary power supply of an engine welder. Special protection circuits may operate causing loss of output.

CONTROLS AND SETTINGS

All operator controls and adjustments are located on the case front of the V100-S and V130-S machines. Refer to Figure B.1 and the corresponding explanations.

FIGURE B.1 — CASE FRONT CONTROLS.

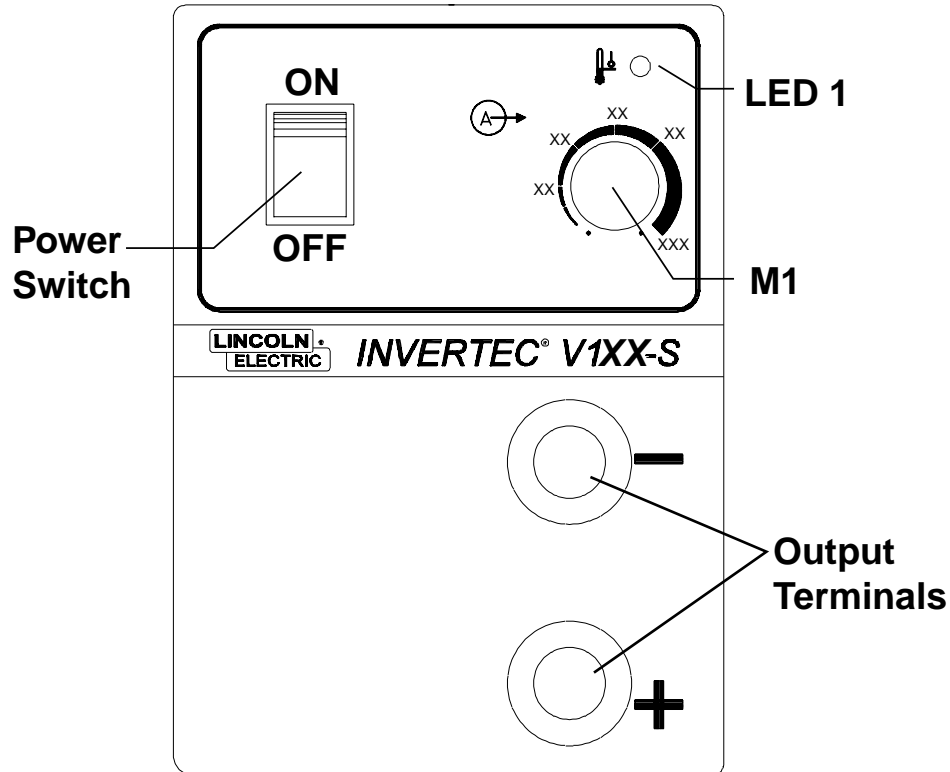

Power Switch - Controls the power input to the machine. This rocker switch is lighted. When power is applied to the machine the light is on.

Knob M1 - Potentiometer used to set the value of the current required by the welding process.

LED 1 - This LED will light up when:

- A) The input supply voltage is not within limits pre-set for correct operation.
V100-S: 95VAC to 125VAC*
V130-S: 200VAC to 255VAC*
- B) The machine is overheated as detected by the internal thermostat.

Output Terminals - These quick disconnect terminals provide connection points for the electrode and work cables. For positive polarity welding connect the electrode cable to the positive terminal and the work cable to the negative terminal. To weld negative polarity reverse the electrode and work cables.

* Note that input voltages that exceed 20% of nominal may cause internal damage to the machine.

CONSTANT CURRENT PROCESSES

MANUAL ARC WELDING (STICK)

The Invertec may be utilized as a manual DC arc welder. The electrode cable and holder and the work cable and clamp are included.

Excellent stick welding performance is easily achieved with the following electrodes and current settings:

Machine	Electrode	Diameter	Current
V100-S	Fleetweld 35	3/32" Max	90 Amps
	Fleetweld 180	3/32"Max	90 Amps
	Fleetweld 37	3/32" Max	100 Amps
	LH-78	3/32" Max	100 Amps
V130-S	Fleetweld 35	1/8" Max	100 Amps
	Fleetweld 180	1/8" Max	100 Amps
	Fleetweld 37	1/8" Max	115 Amps
	LH-78	1/8" Max	130 Amps

TIG WELDING

The Invertecs are capable of scratch start TIG welding. A TIG torch, and gas supply with regulator are required.

OVERLOAD PROTECTION

The machine is electrically protected from producing excessive currents. The maximum current obtainable with the V100-S is approximately 120 amps, and that of the V130-S is approximately 150 amps.

THERMAL PROTECTION

Thermostats protect the machine from excessive operating temperatures. Excessive temperatures may be caused by a lack of cooling air or operating the machine beyond the duty cycle and output rating. If excessive operating temperature should occur, the thermostats will prevent output voltage or current.

Thermostats are self-resetting once the machine cools sufficiently. If the thermostat shutdown was caused by excessive output or duty cycle and the fan is operating normally, the Power Switch may be left on and the reset should occur within a 15 minute period. If the fan is not operating or if the air flow is obstructed, this problem must be resolved before continuing.

OPTIONS / ACCESSORIES

K909-1 - EH-200 Insulated electrode holder designed for maximum operator comfort and convenience.

K859-"L" - LA-9 125 amp air-cooled, lightweight, and versatile TIG torch for thin gauge materials. Includes two piece cable. Available in 12.5 ft. and 25 ft. lengths.

K860-"L" - LA-17V 150 amp air-cooled compact and durable TIG torch for thin to medium gauge materials. Includes valve and two piece cable. Available in 12.5 ft. and 25 ft. lengths.

KP507 - Parts kit for the LA-9 torch. Kit includes back cap, collets, collet bodies, nozzles and tungstens.

KP508 - Parts kit for the LA-17 torch. Kit includes back cap, collets, collet bodies, nozzles and tungstens.

K852-25 - Twist-Mate™ plug for connecting welding cable to output terminals. Contains one plug.

SAFETY PRECAUTIONS



WARNING



ELECTRIC SHOCK can kill.

- Have an electrician install and service this equipment.
- Turn the input power off at the fuse box, disconnect supply lines and allow machine to sit for five minutes minimum to allow the power capacitors to discharge before working inside this equipment.
- Do not touch electrically hot parts.

INPUT FILTER CAPACITOR DISCHARGE PROCEDURE



WARNING

The machine has internal capacitors which are charged to a high voltage during power-on conditions. This voltage is dangerous and must be discharged before the machine can be serviced. Discharging is done automatically by the machine each time the power is switched off. However, you must allow the machine to sit for at least 5 minutes to allow time for the process to take place.

- Printed circuit boards
- Power switch
- Fan blades
- Louvers
- Heat sink fins
- Output terminals

4. Examine capacitors for leakage or oozing. If any leakage is noticed, take the unit to an authorized Lincoln Field Service Shop.
5. Examine the case for breakage. Repair or replace the case as required. Keep the case in good condition to ensure that high voltage parts are protected and correct spacings are maintained.
6. Install machine covers and fasteners.

ROUTINE MAINTENANCE

1. Perform the following preventive maintenance procedures at least once every thousand hours of use. It is good practice to keep a preventive maintenance record; a record tag attached to the machine works best.
2. Remove the machine cover (requires a 3 mm hex key) after allowing the minimum 5 minute power off requirement to let the input capacitors discharge.



WARNING

Failure to observe this discharge time requirement could result in severe electrical shock hazard.

3. Keeping the machine clean will result in cooler operation and higher reliability. Be sure to clean the following areas with a low pressure air stream.

HOW TO USE TROUBLESHOOTING GUIDE

WARNING

Service and Repair should only be performed by Lincoln Electric Factory Trained Personnel. Unauthorized repairs performed on this equipment may result in danger to the technician and machine operator and will invalidate your factory warranty. For your safety and to avoid Electrical Shock, please observe all safety notes and precautions detailed throughout this manual.

This Troubleshooting Guide is provided to help you locate and repair possible machine malfunctions. Simply follow the three-step procedure listed below.

Step 1. LOCATE PROBLEM (SYMPTOM).

Look under the column labeled "PROBLEM (SYMPTOMS)". This column describes possible symptoms that the machine may exhibit. Find the listing that best describes the symptom that the machine is exhibiting.

Step 2. POSSIBLE CAUSE.

The second column labeled "POSSIBLE CAUSE" lists the obvious external possibilities that may contribute to the machine symptom.

Step 3. RECOMMENDED COURSE OF ACTION

This column provides a course of action for the Possible Cause, generally it states to contact you local Lincoln Authorized Field Service Facility.

If you do not understand or are unable to perform the Recommended Course of Action safely, contact you local Lincoln Authorized Field Service Facility.

CAUTION

If for any reason you do not understand the test procedures or are unable to perform the tests/repairs safely, contact your **Local Lincoln Authorized Field Service Facility** for technical troubleshooting assistance before you proceed.

Observe all Safety Guidelines detailed throughout this manual

PROBLEMS (SYMPTOMS)	POSSIBLE AREAS OF MISADJUSTMENTS(S)	RECOMMENDED COURSE OF ACTION
The machine is dead - no output - no fan.	<ol style="list-style-type: none"> 1. The input power switch must be in the ON position. 2. Make sure the input voltage is correct for the machine. 	
No output but the fan operates normally.	<ol style="list-style-type: none"> 1. The machine may be overheated. Check the thermal indicator light. Wait for the machine to cool and the thermostats to reset. 	If all recommended possible areas of misadjustment have been checked and the problem persists, Contact your local Lincoln Authorized Field Service Facility.
Output turns on momentarily, then switches off.	<ol style="list-style-type: none"> 1. Check the input voltage. Make sure the input voltage is correct for the machine. 	
No output - Main input fuses open, indicating excessive current draw.	<ol style="list-style-type: none"> 1. Inspect input leads for possible shorts or grounds or mis-connections. 2. Install new fuses and reapply power. If fuses open again, consult a Lincoln Authorized Field Service Facility. 	

 **CAUTION**

If for any reason you do not understand the test procedures or are unable to perform the tests/repairs safely, contact your **Local Lincoln Authorized Field Service Facility** for technical troubleshooting assistance before you proceed.

INVERTEC® V100-S & V130-S



Observe all Safety Guidelines detailed throughout this manual

PROBLEMS (SYMPTOMS)	POSSIBLE AREAS OF MISADJUSTMENTS(S)	RECOMMENDED COURSE OF ACTION
<p>Poor welding, weld settings drift, or output power is low.</p>	<ol style="list-style-type: none"> 1. Make sure the machine settings are correct for the weld process being used. 2. Make sure the input voltage is correct for the machine. 	
<p>Poor stick electrode welding performance. The arc pops out.</p>	<ol style="list-style-type: none"> 1. Check for loose or faulty welding cables. 2. Is the electrode DRY? Try welding with another electrode from a different container. Make sure you have the correct electrode for the application. 3. Make sure the machine settings are correct for the weld process being used. 	<p>If all recommended possible areas of misadjustment have been checked and the problem persists, Contact your local Lincoln Authorized Field Service Facility.</p>

 **CAUTION**

If for any reason you do not understand the test procedures or are unable to perform the tests/repairs safely, contact your **Local Lincoln Authorized Field Service Facility** for technical troubleshooting assistance before you proceed.

INVERTEC® V100-S & V130-S



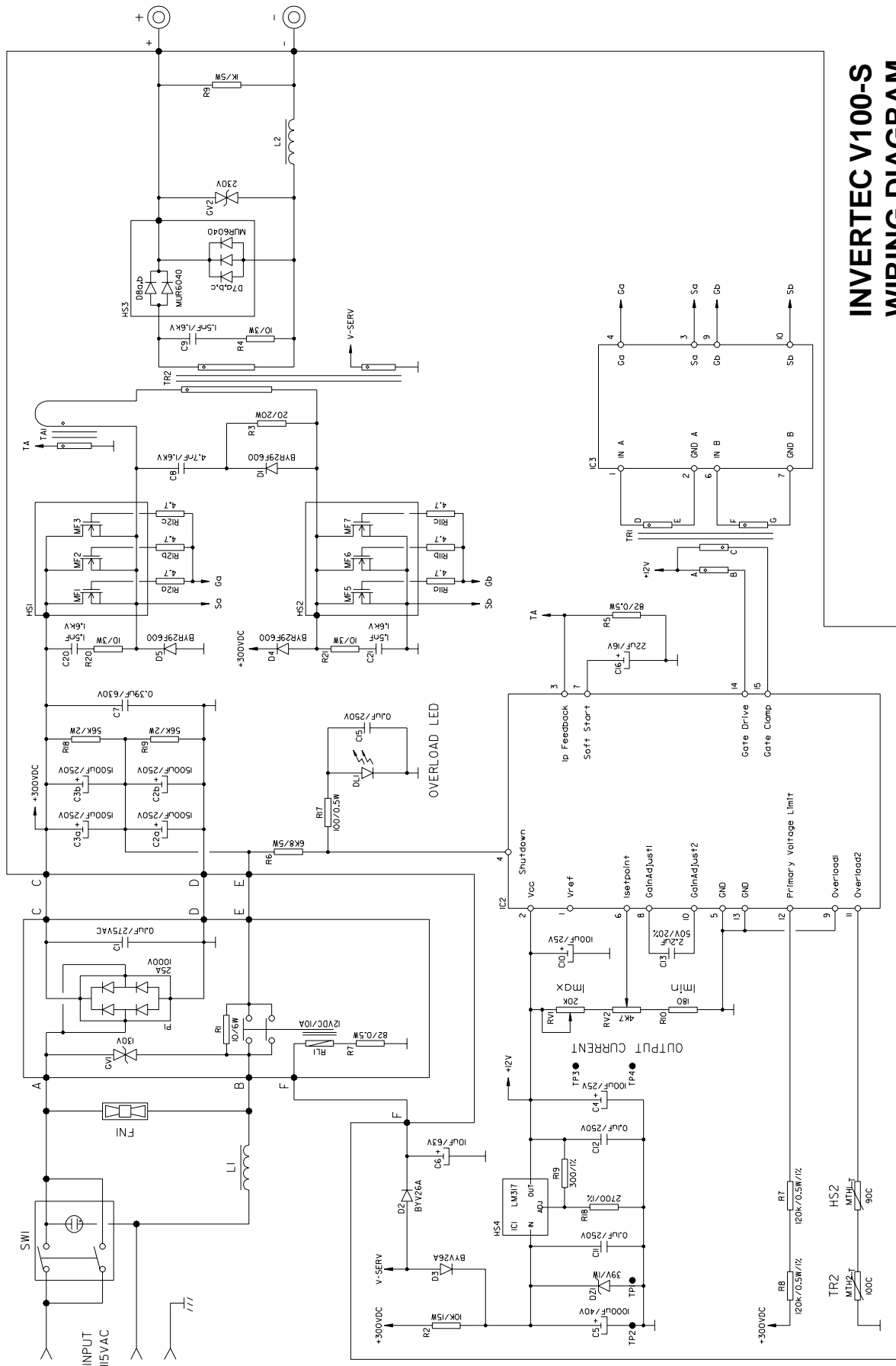

INVERTEC V100-S WIRING DIAGRAM

8-21-98
M18980

NOTE: This diagram is for reference only. It may not be accurate for all machines covered by this manual. The specific diagram for a particular code is pasted inside the machine on one of the enclosure panels. If the diagram is illegible, write to the Service Department for a replacement. Give the equipment code number..

INVERTEC® V100-S & V130-S



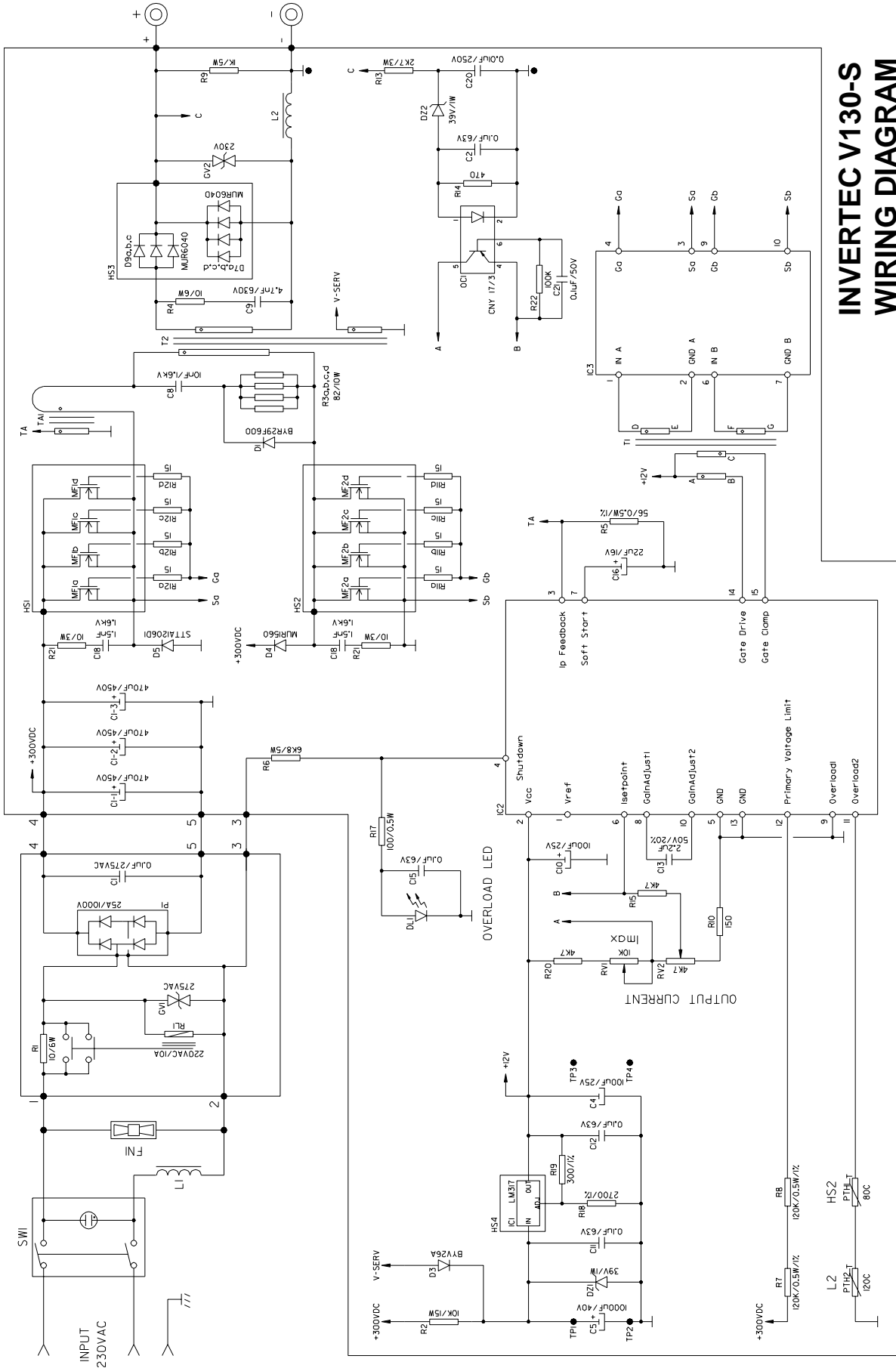

**INVERTEC V130-S
WIRING DIAGRAM**

8-21-98
M18985

NOTE: This diagram is for reference only. It may not be accurate for all machines covered by this manual. The specific diagram for a particular code is pasted inside the machine on one of the enclosure panels. If the diagram is illegible, write to the Service Department for a replacement. Give the equipment code number..

WARNING	<ul style="list-style-type: none"> ● Do not touch electrically live parts or electrode with skin or wet clothing. ● Insulate yourself from work and ground. 	<ul style="list-style-type: none"> ● Keep flammable materials away. 	<ul style="list-style-type: none"> ● Wear eye, ear and body protection.
Spanish AVISO DE PRECAUCION	<ul style="list-style-type: none"> ● No toque las partes o los electrodos bajo carga con la piel o ropa mojada. ● Aislese del trabajo y de la tierra. 	<ul style="list-style-type: none"> ● Mantenga el material combustible fuera del área de trabajo. 	<ul style="list-style-type: none"> ● Protéjase los ojos, los oídos y el cuerpo.
French ATTENTION	<ul style="list-style-type: none"> ● Ne laissez ni la peau ni des vêtements mouillés entrer en contact avec des pièces sous tension. ● Isolez-vous du travail et de la terre. 	<ul style="list-style-type: none"> ● Gardez à l'écart de tout matériel inflammable. 	<ul style="list-style-type: none"> ● Protégez vos yeux, vos oreilles et votre corps.
German WARNUNG	<ul style="list-style-type: none"> ● Berühren Sie keine stromführenden Teile oder Elektroden mit Ihrem Körper oder feuchter Kleidung! ● Isolieren Sie sich von den Elektroden und dem Erdboden! 	<ul style="list-style-type: none"> ● Entfernen Sie brennbares Material! 	<ul style="list-style-type: none"> ● Tragen Sie Augen-, Ohren- und Körperschutz!
Portuguese ATENÇÃO	<ul style="list-style-type: none"> ● Não toque partes elétricas e electrodos com a pele ou roupa molhada. ● Isole-se da peça e terra. 	<ul style="list-style-type: none"> ● Mantenha inflamáveis bem guardados. 	<ul style="list-style-type: none"> ● Use proteção para a vista, ouvido e corpo.
Japanese 注意事項	<ul style="list-style-type: none"> ● 通電中の電気部品、又は溶材にヒフやぬれた布で触れないこと。 ● 施工物やアースから身体が絶縁されている様にして下さい。 	<ul style="list-style-type: none"> ● 燃えやすいものの側での溶接作業は絶対にしてはなりません。 	<ul style="list-style-type: none"> ● 目、耳及び身体に保護具をして下さい。
Chinese 警告	<ul style="list-style-type: none"> ● 皮膚或濕衣物切勿接觸帶電部件及鎢條。 ● 使你自已與地面和工件絕緣。 	<ul style="list-style-type: none"> ● 把一切易燃物品移離工作場所。 	<ul style="list-style-type: none"> ● 佩戴眼、耳及身體勞動保護用具。
Korean 위험	<ul style="list-style-type: none"> ● 전도체나 용접봉을 젖은 형갑 또는 피부로 절대 접촉치 마십시오. ● 모재와 접지를 접촉치 마십시오. 	<ul style="list-style-type: none"> ● 인화성 물질을 접근시키지 마십시오. 	<ul style="list-style-type: none"> ● 눈, 귀와 몸에 보호장구를 착용하십시오.
Arabic تحذير	<ul style="list-style-type: none"> ● لا تلمس الاجزاء التي يسري فيها التيار الكهربائي أو الألكترود بجسدك أو بالملابس المبللة بالماء. ● ضع عازلا على جسمك خلال العمل. 	<ul style="list-style-type: none"> ● ضع المواد القابلة للاشتعال في مكان بعيد. 	<ul style="list-style-type: none"> ● ضع أدوات وملابس واقية على عينيك وأذنيك وجسمك.

READ AND UNDERSTAND THE MANUFACTURER'S INSTRUCTION FOR THIS EQUIPMENT AND THE CONSUMABLES TO BE USED AND FOLLOW YOUR EMPLOYER'S SAFETY PRACTICES.

SE RECOMIENDA LEER Y ENTENDER LAS INSTRUCCIONES DEL FABRICANTE PARA EL USO DE ESTE EQUIPO Y LOS CONSUMIBLES QUE VA A UTILIZAR, SIGA LAS MEDIDAS DE SEGURIDAD DE SU SUPERVISOR.

LISEZ ET COMPRENEZ LES INSTRUCTIONS DU FABRICANT EN CE QUI REGARDE CET EQUIPMENT ET LES PRODUITS A ETRE EMPLOYES ET SUIVEZ LES PROCEDURES DE SECURITE DE VOTRE EMPLOYEUR.

LESEN SIE UND BEFOLGEN SIE DIE BETRIEBSANLEITUNG DER ANLAGE UND DEN ELEKTRODENEINSATZ DES HERSTELLERS. DIE UNFALLVERHÜTUNGSVORSCHRIFTEN DES ARBEITGEBERS SIND EBENFALLS ZU BEACHTEN.

			
<ul style="list-style-type: none"> ● Keep your head out of fumes. ● Use ventilation or exhaust to remove fumes from breathing zone. 	<ul style="list-style-type: none"> ● Turn power off before servicing. 	<ul style="list-style-type: none"> ● Do not operate with panel open or guards off. 	WARNING
<ul style="list-style-type: none"> ● Los humos fuera de la zona de respiración. ● Mantenga la cabeza fuera de los humos. Utilice ventilación o aspiración para gases. 	<ul style="list-style-type: none"> ● Desconectar el cable de alimentación de poder de la máquina antes de iniciar cualquier servicio. 	<ul style="list-style-type: none"> ● No operar con panel abierto o guardas quitadas. 	Spanish AVISO DE PRECAUCION
<ul style="list-style-type: none"> ● Gardez la tête à l'écart des fumées. ● Utilisez un ventilateur ou un aspirateur pour ôter les fumées des zones de travail. 	<ul style="list-style-type: none"> ● Débranchez le courant avant l'entretien. 	<ul style="list-style-type: none"> ● N'opérez pas avec les panneaux ouverts ou avec les dispositifs de protection enlevés. 	French ATTENTION
<ul style="list-style-type: none"> ● Vermeiden Sie das Einatmen von Schweißrauch! ● Sorgen Sie für gute Be- und Entlüftung des Arbeitsplatzes! 	<ul style="list-style-type: none"> ● Strom vor Wartungsarbeiten abschalten! (Netzstrom völlig öffnen; Maschine anhalten!) 	<ul style="list-style-type: none"> ● Anlage nie ohne Schutzgehäuse oder Innenschutzverkleidung in Betrieb setzen! 	German WARNUNG
<ul style="list-style-type: none"> ● Mantenha seu rosto da fumaça. ● Use ventilação e exaustão para remover fumo da zona respiratória. 	<ul style="list-style-type: none"> ● Não opere com as tampas removidas. ● Desligue a corrente antes de fazer serviço. ● Não toque as partes elétricas nuas. 	<ul style="list-style-type: none"> ● Mantenha-se afastado das partes moventes. ● Não opere com os painéis abertos ou guardas removidas. 	Portuguese ATENÇÃO
<ul style="list-style-type: none"> ● ヒュームから頭を離すようにして下さい。 ● 換気や排煙に十分留意して下さい。 	<ul style="list-style-type: none"> ● メンテナンス・サービスに取りかかる際には、まず電源スイッチを必ず切ってください。 	<ul style="list-style-type: none"> ● パネルやカバーを取り外したままで機械操作をしないで下さい。 	Japanese 注意事項
<ul style="list-style-type: none"> ● 頭部遠離煙霧。 ● 在呼吸區使用通風或排風器除煙。 	<ul style="list-style-type: none"> ● 維修前切斷電源。 	<ul style="list-style-type: none"> ● 儀表板打開或沒有安全罩時不準作業。 	Chinese 警告
<ul style="list-style-type: none"> ● 얼굴로부터 용접가스를 멀리하십시오. ● 호흡지역으로부터 용접가스를 제거하기 위해 가스제거기나 통풍기를 사용하십시오. 	<ul style="list-style-type: none"> ● 보수전에 전원을 차단하십시오. 	<ul style="list-style-type: none"> ● 판넬이 열린 상태로 작동치 마십시오. 	Korean 위험
<ul style="list-style-type: none"> ● ابعد رأسك بعيداً عن الدخان. ● استعمل التهوية أو جهاز ضغط الدخان للخارج لكي تبعد الدخان عن المنطقة التي تتنفس فيها. 	<ul style="list-style-type: none"> ● أقطع التيار الكهربائي قبل القيام بأية صيانة. 	<ul style="list-style-type: none"> ● لا تشغيل هذا الجهاز اذا كانت الاغطية الحديدية الواقية ليست عليه. 	Arabic تحذير

LEIA E COMPREENDA AS INSTRUÇÕES DO FABRICANTE PARA ESTE EQUIPAMENTO E AS PARTES DE USO, E SIGA AS PRÁTICAS DE SEGURANÇA DO EMPREGADOR.

使う機械や溶材のメーカーの指示書をよく読み、まず理解して下さい。そして貴社の安全規定に従って下さい。

請詳細閱讀並理解製造廠提供的說明以及應該使用的銀焊材料，並請遵守貴方的有閣勞動保護規定。

이 제품에 동봉된 작업지침서를 숙지하시고 귀사의 작업자 안전수칙을 준수하시기 바랍니다.

اقرأ بتمعن وافهم تعليمات المصنع المنتج لهذه المعدات والمواد قبل استعمالها واتبع تعليمات الوقاية لصاحب العمل.



• World's Leader in Welding and Cutting Products •

• Sales and Service through Subsidiaries and Distributors Worldwide •

Cleveland, Ohio 44117-1199 U.S.A. TEL: 216.481.8100 FAX: 216.486.1751 WEB SITE: www.lincolnelectric.com