

DC-600 (230/460/575) WIRING DIAGRAM G3606-5 REV: A

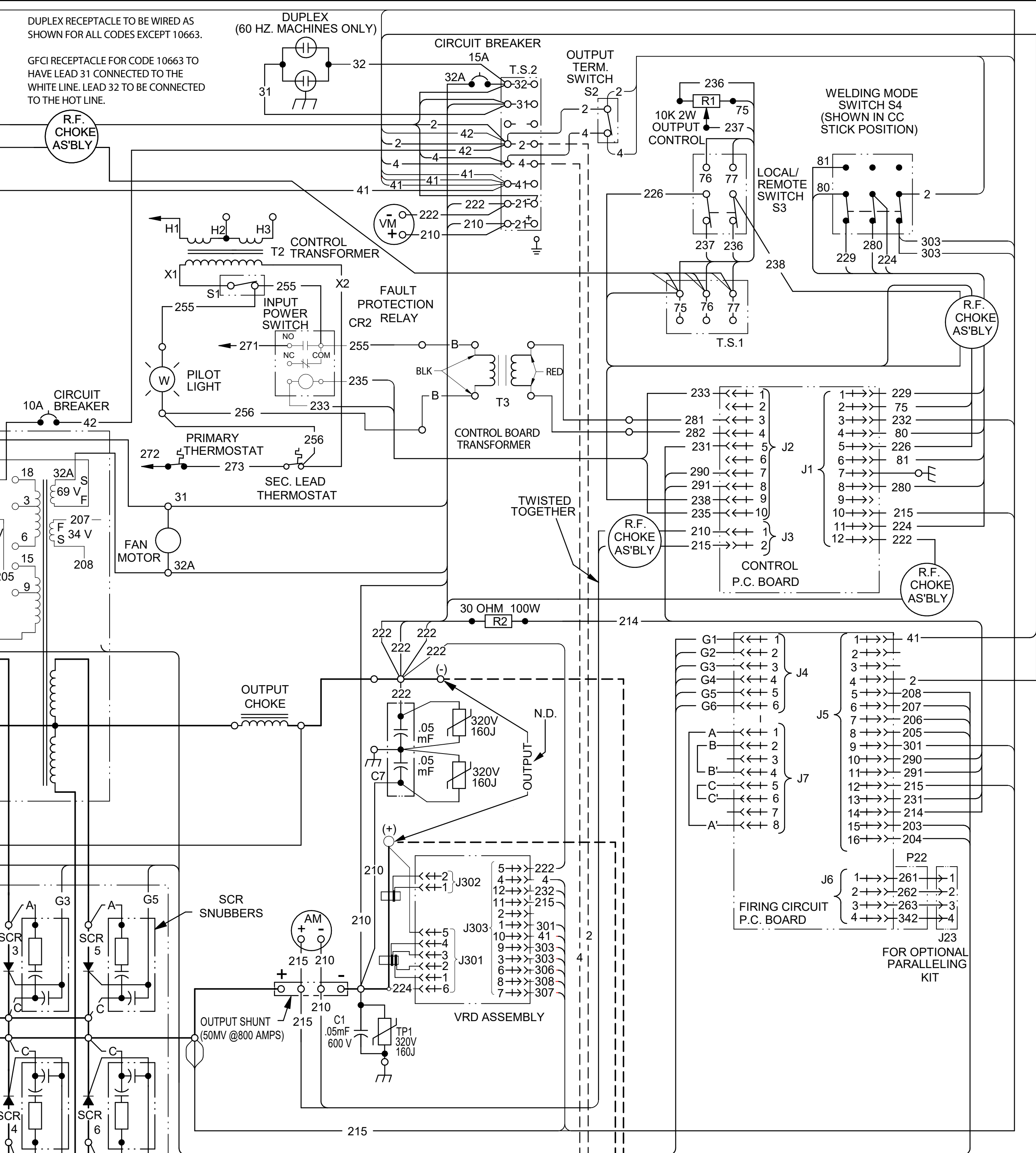

- NOTES:**
- N.C. LOCATION OF THIS LEAD ON T.S.2 TERMINAL STRIP MAY VARY. SEE IM MANUAL FOR LOCATION.
 - N.D. WELDING CABLE MUST BE OF THE PROPER CAPACITY FOR THE CURRENT AND DUTY CYCLE OF IMMEDIATE AND FUTURE APPLICATIONS.
 - N.E. ▲ THIS DIAGRAM SHOWS THE "STICK" POLARITY "POSITIVE". TO CHANGE THE POLARITY, TURN THE DC-600 OFF, AND REVERSE THE LEADS AT THE MULTI-PROCESS SWITCH.
 - N.F. ▲ USING A WIRE FEEDER, K-317 OR K-318 CONNECTION DIAGRAM, CONNECT ELECTRODE AND WORK LEADS TO THESE TERMINALS INSTEAD OF THE POWER SOURCE OUTPUT TERMINALS.
 - N.G. TAPE UP SEPARATELY TO PROVIDE AT LEAST 600V INSULATION.
 - ▲ THESE NOTES APPLY ONLY TO DC-600 WITH A MULTI-PROCESS SWITCH INSTALLED.

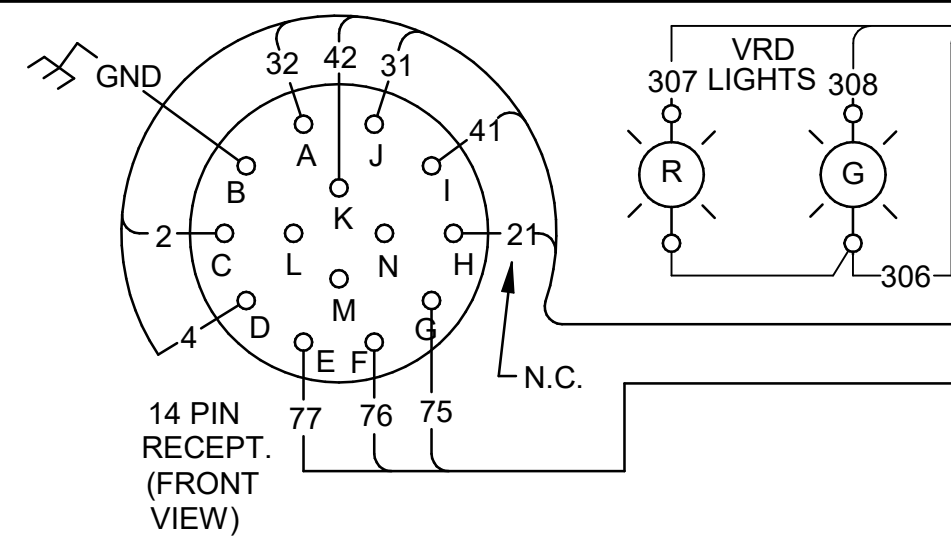
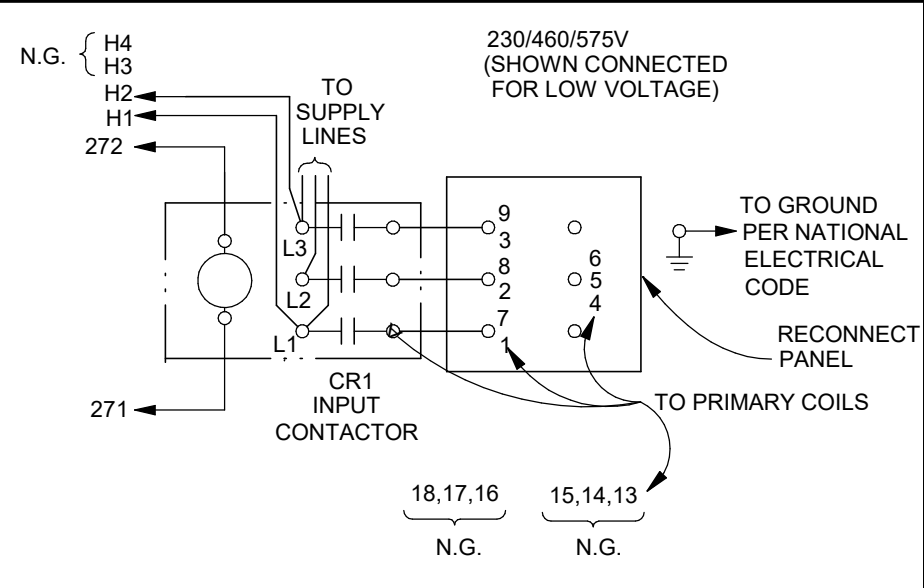
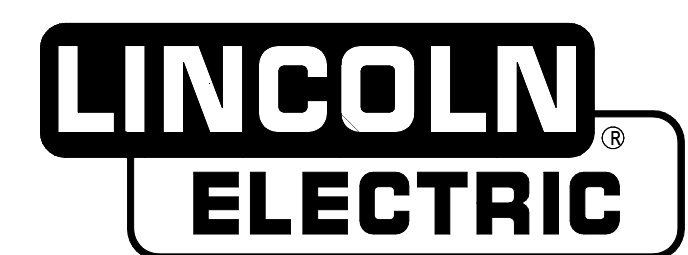
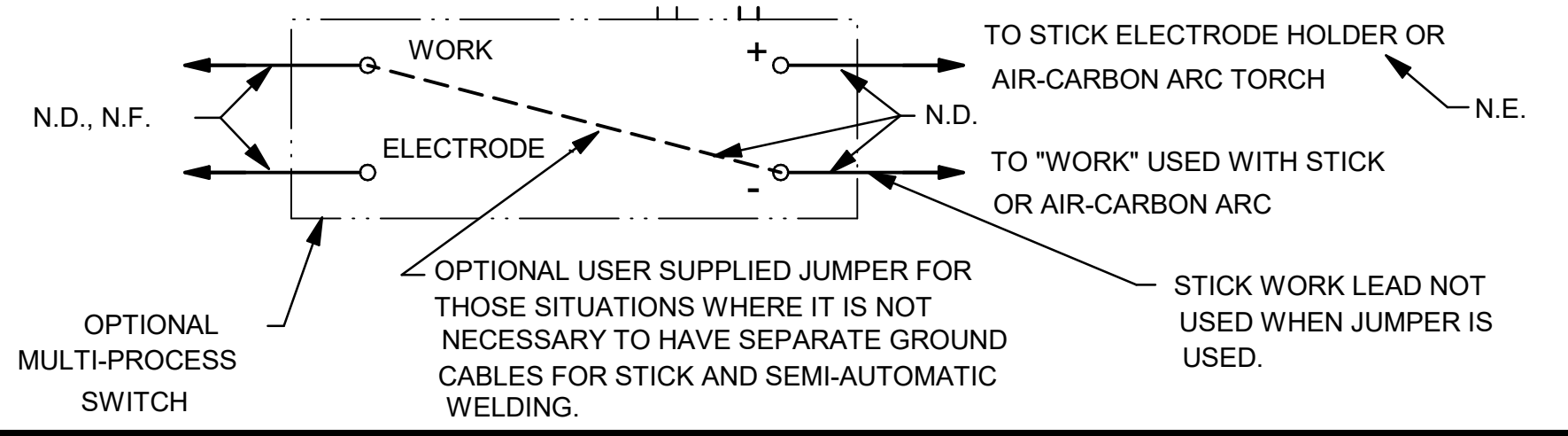
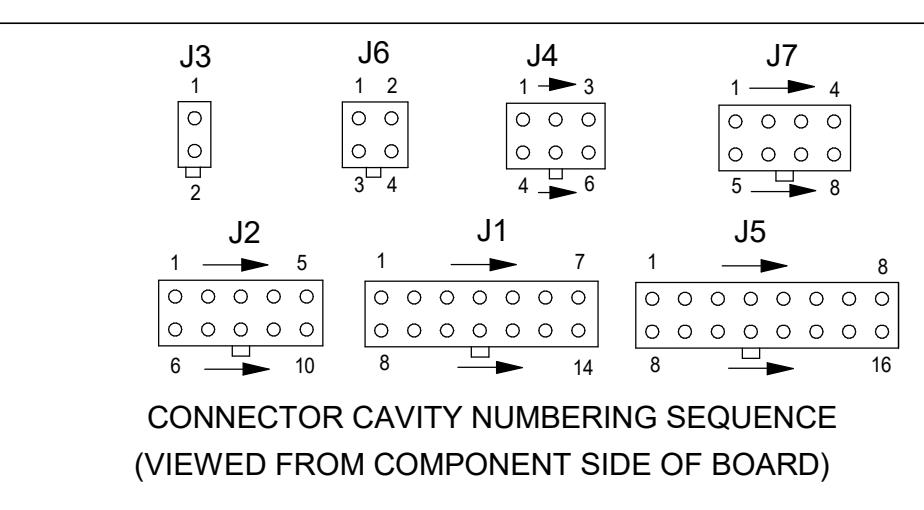

CLEVELAND, OHIO U.S.A.