

WF 52D WF 56D

Spare Parts	1
Figure A: WF 52D & WF 56D Machine Assembly	2
Figure B: WF 52D & WF 56D Partition Assembly	3
Figure C: WF 52D & WF 56D Wire Drive Assembly	4
Figure D: WF-52D & WF-56D Front Assembly	6
Figure E: WF-52D & WF-56D Back Panel	7
Miscellaneous Items (not shown in figure A, B, C, D, E)	7
Electrical Schematic	8
CODE: 50448	8
CODE: 50449	9



Spare Parts

SP50508, SP50509 REV01
01/2024

ASSEMBLY PAGE NAME			Machine Assembly	Partition Assembly	Wire Drive Assembly	Front Assembly	Back Panel	Miscellaneous Items
CODE NO.:	K NO.:	FIGURE NO.:	A	B	C	D	G	
50508	W000404460	WF 52D	1	1	1	1	1	1
50509	W000404461	WF 56D	2	2	2	2	2	2

*items highlighted in bold are recommended spare parts

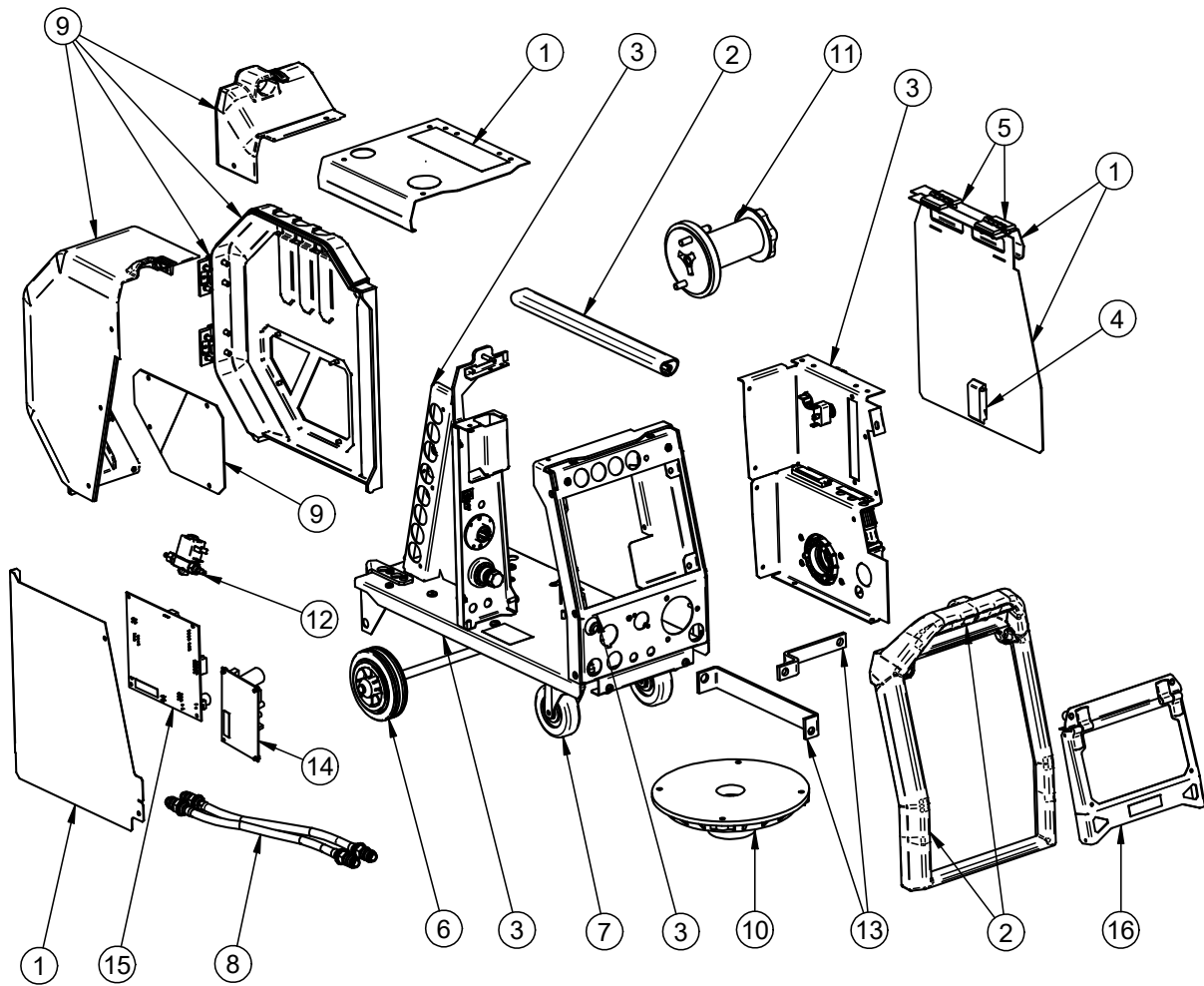

Figure A

Figure A: WF 52D & WF 56D Machine Assembly

Item	Description	Part Number	QTY	1	2	3	4	5	6	7
1	SIDE PANEL KIT includes:	T-8040-066-1R	1	X	X					
	LEFT SIDE PANEL		1	X	X					
	RIGHT SIDE PANEL		1	X	X					
	COVER		1	X	X					
	LABLE		5	X	X					
	SHEWF		1	X	X					
2	FRONT PANEL FRAME KIT:	T-8040-067-1R	1	X	X					
	FRONT PANEL		1	X	X					
	RED INSERT		1	X	X					
	HANDLE		1	X	X					
3	BASE, PARTITION, SHEWF KIT:	T-8040-041-1R	1	X						
	BASE ASSEMBLY		1	X						
	PARTITION ASSEMBLY		1	X						
	PARTITION LABEL		1	X						
	FRONT PANEL		1	X						
	BACK LABEL		1	X						
	BRACKET		1	X						
3	BASE, PARTITION, SHEWF KIT:	T-8040-048-1R	1		X					
	BASE ASSEMBLY		1		X					
	PARTITION ASSEMBLY		1		X					
	PARTITION LABEL		1		X					
	FRONT PANEL		1		X					
	BACK LABEL		1		X					
	BRACKET		1		X					
4	LOCK	0654-610-004R	1	X	X					
5	LEAF HINGE	0654-610-007R	2	X	X					
6	WHEELS	1029-660-006R	2	X	X					
7	WHELLS	1029-660-004R	2	X	X					
8	WATER CONNECTION KIT:	T-8040-043-1R	1	X	X					
	COOLING HOSES		2	X	X					
	QUICK CONNECTOR		4	X	X					
9	PLASTIC COVER KIT	T-8040-068-1R	1	X	X					
10	ROTARY BRACKET	1361-598-180R	1	X	X					
11	REEL HUB STANDARD	0744-000-192R	1	X	X					
12	GAS SOLENOID	W8500011R	1	X	X					
13	CONDUCTOR RAILS KIT	T-8040-045-1R	1	X	X					
14	CONTROL BOARD	R-6042-096-1R	1	X						
15	CONTROL BOARD	R-6042-094-1R	1		X					
16	CONTROL PANEL COVER KIT	T-8040-058-1R	1		X					

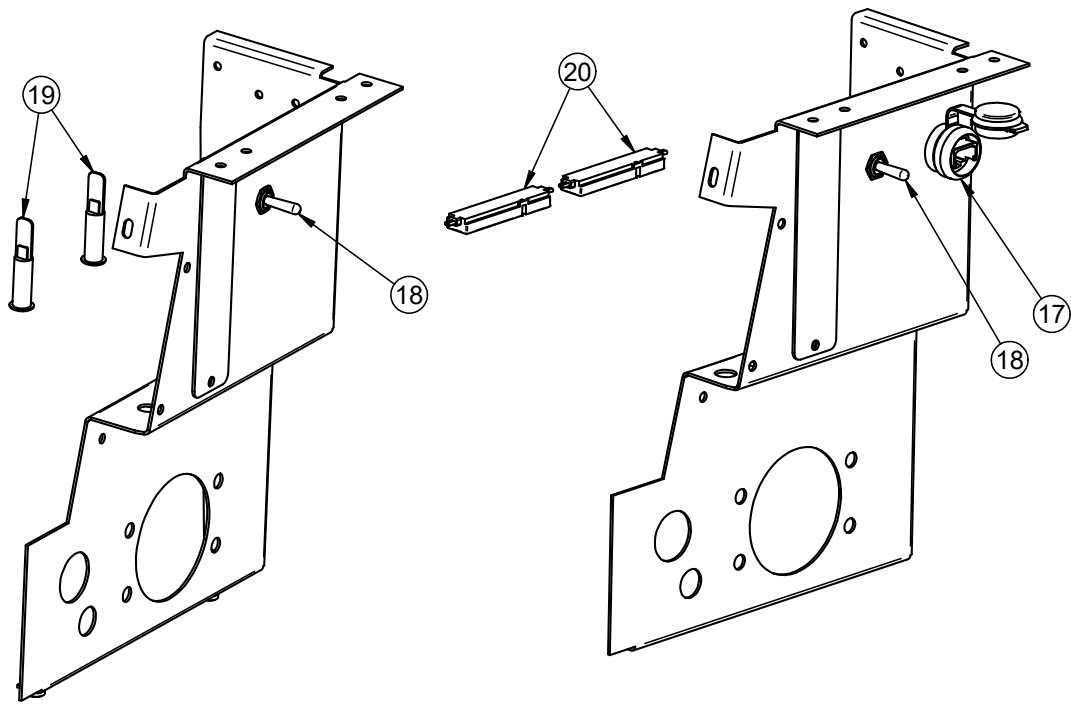

Figure B

Figure B: WF 52D & WF 56D Partition Assembly

Item	Description	Part Number	QTY	1	2	3	4	5	6	7
17	USB SOCKET	1158-641-061R	1		X					
18	SWITCH	1115-280-004R	1	X	X					
19	WHITE LAMP	0917-421-049R	2	X						
20	LED MODULE	R-5041-508-1R	2		X					

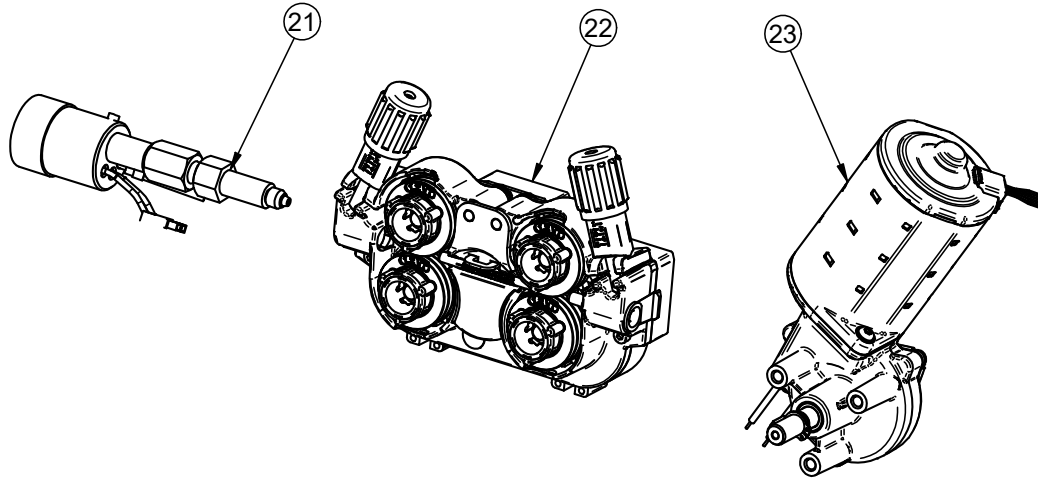

Figure C

Figure C: WF 52D & WF 56D Wire Drive Assembly

Item	Description	Part Number	QTY	1	2	3	4	5	6	7
21	EURO SOCKET	T-8040-051-1R	1	X	X					
22	WIRE FEEDER	0744-000-009R	1	X	X					
23	WIRE MOTOR	T-8040-049-1R	1	X	X					

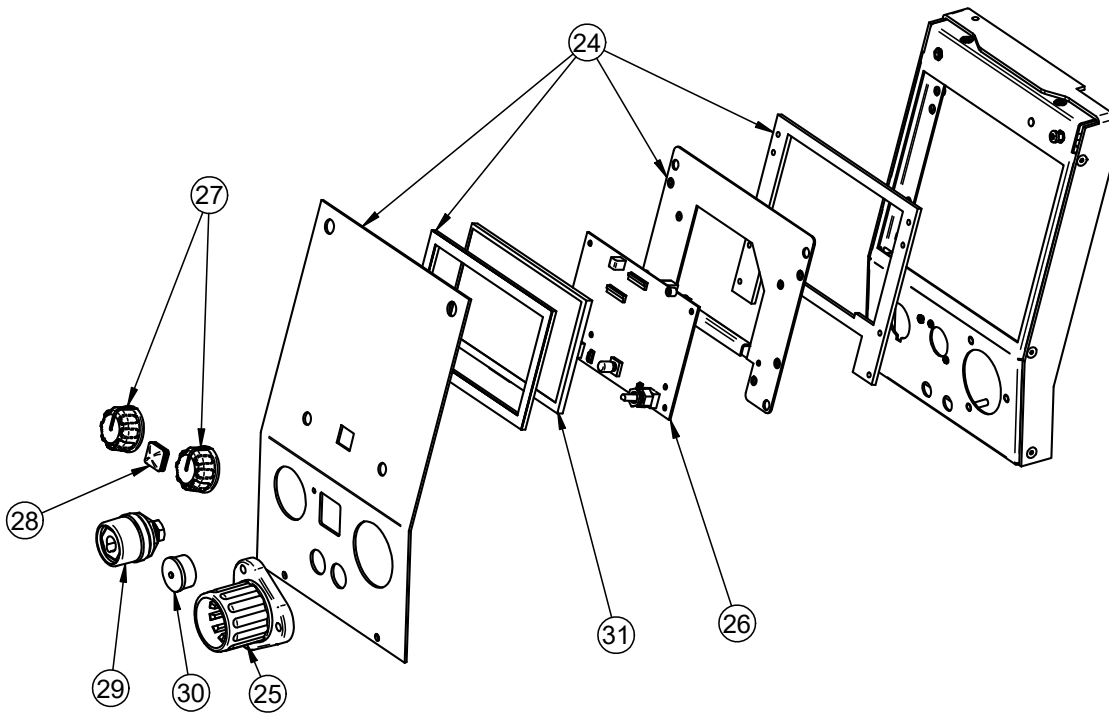
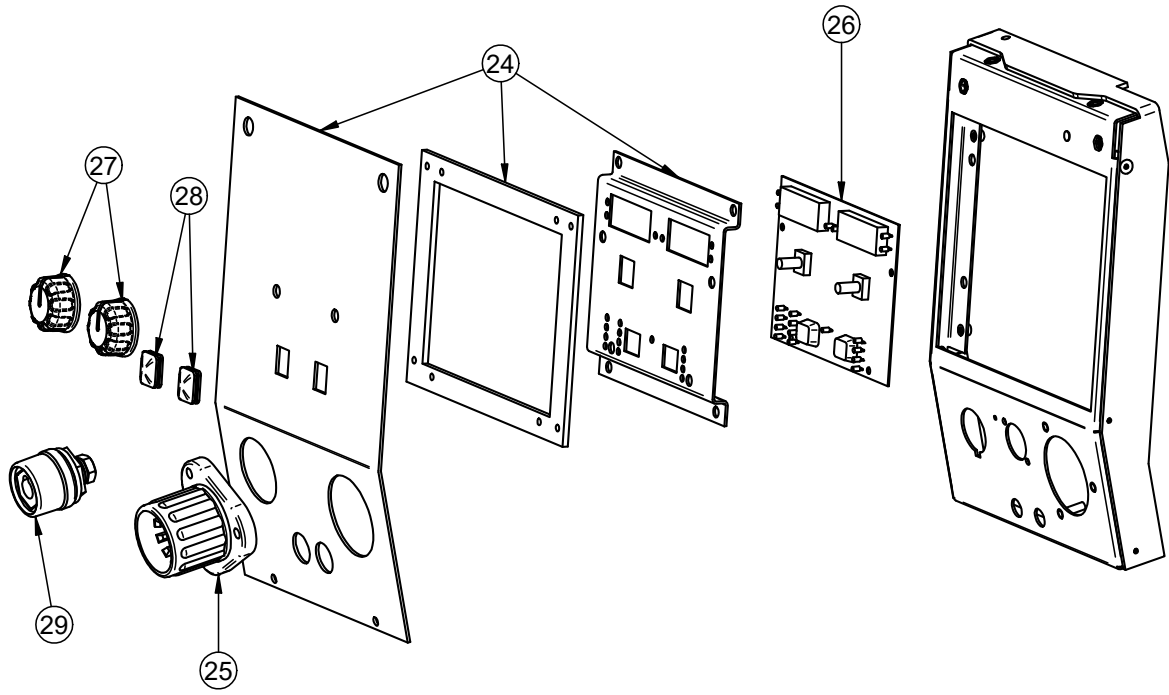

Figure D

Figure D: WF-52D & WF-56D Front Assembly

Item	Description	Part Number	QTY	1	2	3	4	5	6	7
24	FRONT PANEL KIT:	T-8040-075-1R	1	X						
	DISPLAY FRONT PANEL		1	X						
	BRACKET		1	X						
	BRACKET		1	X						
24	FRONT PANEL KIT:	T-8040-076-1R	1		X					
	DISPLAY FRONT PANEL		1		X					
	DISPLAY GASKET		1		X					
	BRACKET		1		X					
	BRACKET		1		X					
25	EURO SLEEVE	C-1891-006-1R	1	X	X					
26	USER INTERFACE PCB	R-6042-078-1R	1	X						
	USER INTERFACE PCB	R-6042-077-1R	1		X					
27	KNOB	9SM22778-2	2	X	X					
28	BUTTON	9SS23055	2	X						
	BUTTON	9SS23055	1		X					
29	SOCKET	90000595PR	1	X	X					
30	SOCKET COVER	1158-641-159R	1		X					
31	LCD	0942-177-002R	1		X					

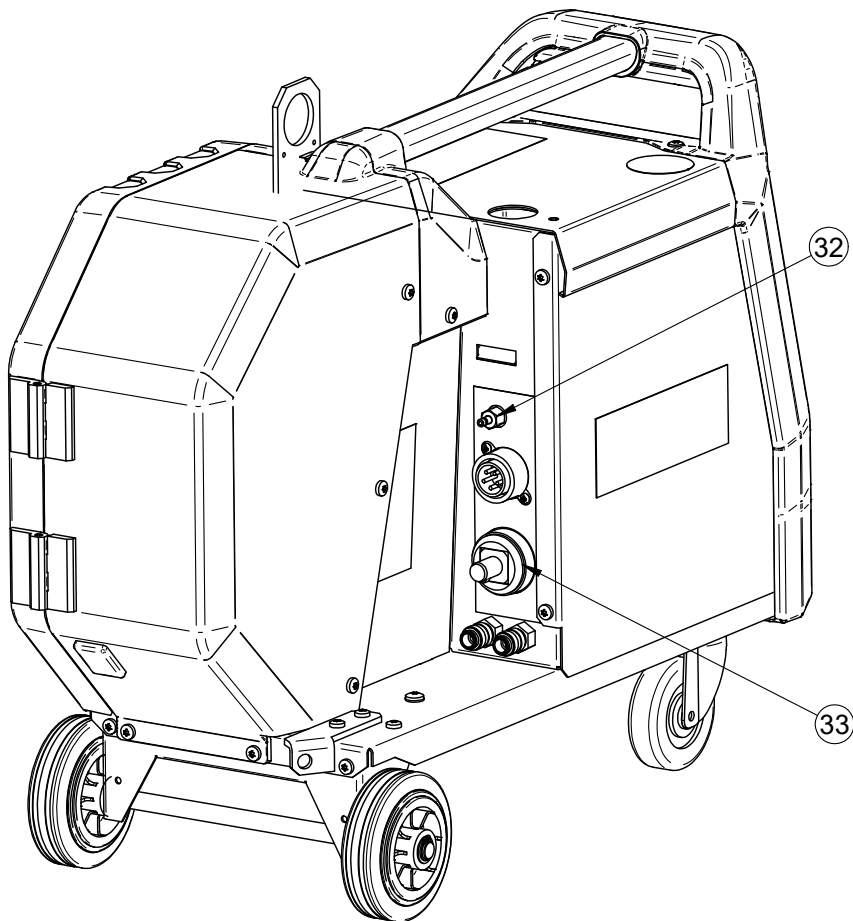

Figure E

Figure E: WF-52D & WF-56D Back Panel

Item	Description	Part Number	QTY	1	2	3	4	5	6	7
32	GAS CONNECTION KIT	T-8040-055-1R	1	X	X					
33	SOCKET	D-2985-002-1R	1	X	X					

Miscellaneous Items (not shown in figure A, B, C, D, E)

Item	Description	Part Number	QTY	1	2	3	4	5	6	7
34	HARNESS KIT	T-8040-053-1R	1	X						
35	HARNESS KIT	T-8040-054-1R	1		X					

Electrical Schematic

CODE: 50448

