



IM-312

IM312
Idealarc SP-200
8313; 8486; 8499; 8500; 8515; 8516;
8765; 8766; 8767; 8772; 8773; 8949;
8975; 8976; 9027; 9028; 9029; 9030;
9031; 9032; 9033; 9034; 9035; 9106;
9107; 9109; 9110

OPERATING MANUAL

IDEALARC® SP-200

**SINGLE PHASE, CONSTANT VOLTAGE
DC ARC WELDING POWER SOURCE
AND SEMIAUTOMATIC WIRE FEEDER**

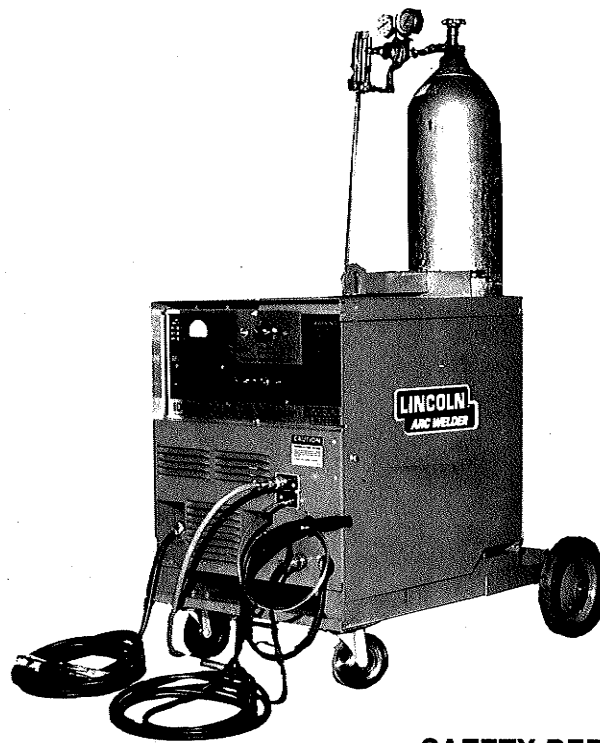

This manual covers equipment which is obsolete and no longer in production by The Lincoln Electric Co. Specifications and availability of optional features may have changed.

DAMAGE CLAIMS

When this equipment is shipped, title passes to the purchaser upon receipt by the carrier. Consequently, claims for material damaged in shipment must be made by the purchaser against the transportation company at the time the shipment is received.

SAFETY DEPENDS ON YOU

Lincoln arc welding equipment is designed and built with safety in mind. However, your overall safety can be increased by proper installation . . . and thoughtful operation on your part. **DO NOT INSTALL, OPERATE OR REPAIR THIS EQUIPMENT WITHOUT READING THIS OPERATING MANUAL AND THE ARC WELDING SAFETY PRECAUTIONS ON THE INSIDE FRONT COVER.** And, most importantly, think before you act and be careful.



THE LINCOLN ELECTRIC COMPANY

World's Largest Manufacturer of Arc Welding Products • Manufacturer of Industrial Motors
Sales and Service Worldwide Cleveland, Ohio 44117-1199 U.S.A.

ARC WELDING SAFETY PRECAUTIONS



WARNING: PROTECT YOURSELF AND OTHERS FROM POSSIBLE SERIOUS INJURY OR DEATH.



ELECTRIC SHOCK can kill.

1. a. The electrode and work (or ground) circuits are electrically "hot" when the welder is on. Do not touch these "hot" parts with your bare skin or wet clothing. Wear dry, hole-free gloves to insulate hands.
- b. In semiautomatic or automatic wire welding, the electrode, electrode reel, welding head, nozzle or semiautomatic welding gun are also electrically "hot".
- c. Insulate yourself from work and ground using dry insulation. When welding in damp locations, on metal framework such as floors, gratings or scaffolds, and when in positions such as sitting or lying, make certain the insulation is large enough to cover your full area of physical contact with work and ground.
- d. Always be sure the work cable makes a good electrical connection with the metal being welded. The connection should be as close as possible to the area being welded.
- e. Ground the work or metal to be welded to a good electrical (earth) ground.
- f. Maintain the electrode holder, work clamp, welding cable and welding machine in good, safe operating condition. Replace damaged insulation.
- g. Never dip the electrode in water for cooling.
- h. Never simultaneously touch electrically "hot" parts of electrode holders connected to two welders because voltage between the two can be the total of the open circuit voltage of both welders.
- i. When working above floor level, protect yourself from a fall should you get a shock.
- j. Also see Items 4c and 6.



ARC RAYS can burn.

2. a. Use a shield with the proper filter and cover plates to protect your eyes from sparks and the rays of the arc when welding or observing open arc welding. Headshield and filter lens should conform to ANSI Z87.1 standards.
- b. Use suitable clothing made from durable flame-resistant material to protect your skin and that of your helpers from the arc rays.
- c. Protect other nearby personnel with suitable non-flammable screening and/or warn them not to watch the arc nor expose themselves to the arc rays or to hot spatter or metal.



FUMES AND GASES can be dangerous.

3. a. Welding may produce fumes and gases hazardous to health. Avoid breathing these fumes and gases. When welding, keep your head out of the fume. Use enough ventilation and/or exhaust at the arc to keep fumes and gases away from the breathing zone. When welding on galvanized, lead or cadmium plated steel and other metals which produce toxic fumes, even greater care must be taken.
- b. Do not weld in locations near chlorinated hydrocarbon vapors coming from degreasing, cleaning or spraying operations. The heat and rays of the arc can react with solvent vapors to form phosgene, a highly toxic gas, and other irritating products.
- c. Shielding gases used for arc welding can displace air and cause injury or death. Always use enough ventilation, especially in confined areas, to insure breathing air is safe.
- d. Read and understand the manufacturer's instructions for this equipment and the consumables to be used, including the material safety data sheet (MSDS) and follow your employer's safety practices.
- e. Also see item 7b.



WELDING SPARKS can cause fire or explosion.

4. a. Remove fire hazards from the welding area. If this is not possible, cover them to prevent the welding sparks from starting a fire. Remember that welding sparks and hot materials from welding can easily go through small cracks and openings to adjacent areas. Have a fire extinguisher readily available.
- b. Where compressed gases are to be used at the job site, special precautions should be used to prevent hazardous situations. Refer to "Safety in Welding and Cutting" (ANSI Standard Z49.1) and the operating information for the equipment being used.
- c. When not welding, make certain no part of the electrode circuit is touching the work or ground. Accidental contact can cause overheating and create a fire hazard.
- d. Do not heat, cut or weld tanks, drums or containers until the proper steps have been taken to insure that such procedures will not cause flammable or toxic vapors from substances inside. They can cause an explosion even though they have been "cleaned." For information purchase "Recommended Safe Practices for the Preparation for

Welding and Cutting of Containers and Piping That Have Held Hazardous Substances”, AWS F4.1-80 from the American Welding Society (see address below).

- e. Vent hollow castings or containers before heating, cutting or welding. They may explode.
- f. Sparks and spatter are thrown from the welding arc. Wear oil free protective garments such as leather gloves, heavy shirt, cuffless trousers, high shoes and a cap over your hair. Wear ear plugs when welding out of position or in confined places. Always wear safety glasses with side shields when in a welding area.
- g. Connect the work cable to the work as close to the welding area as practical. Work cables connected to the building framework or other locations away from the welding area increase the possibility of the welding current passing through lifting chains, crane cables or other alternate circuits. This can create fire hazards or overheat lifting chains or cables until they fail.
- h. Also see item 7c.



CYLINDER may explode if damaged.

5. a. Use only compressed gas cylinders containing the correct shielding gas for the process used and properly operating regulators designed for the gas and pressure used. All hoses, fittings, etc. should be suitable for the application and maintained in good condition.
- b. Always keep cylinders in an upright position securely chained to an undercarriage or fixed support.
- c. Cylinders should be located:
 - Away from areas where they may be struck or subjected to physical damage.
 - A safe distance from arc welding or cutting operations and any other source of heat, sparks, or flame.
- d. Never allow the electrode, electrode holder, or any other electrically “hot” parts to touch a cylinder.
- e. Keep your head and face away from the cylinder valve outlet when opening the cylinder valve.
- f. Valve protection caps should always be in place and handtight except when the cylinder is in use or connected for use.
- g. Read and follow the instructions on compressed gas cylinders, associated equipment, and CGA publication P-1, “Precautions for Safe Handling of Compressed Gases in Cylinders,” available from the Compressed Gas Association, 1235 Jefferson Davis Highway, Arlington, VA 22202.



FOR ELECTRICALLY powered equipment.

6. a. Turn off input power using the disconnect switch at the fuse box before working on the equipment.
- b. Install equipment in accordance with the National Electrical Code, all local codes and the manufacturer's recommendations.
- c. Ground the equipment in accordance with the National Electrical Code and the manufacturer's recommendations.



FOR ENGINE powered equipment.

7. a. Turn the engine off before troubleshooting and maintenance work unless the maintenance work requires it to be running.



- b. Operate engines in open, well-ventilated areas or vent the engine exhaust fumes outdoors.



- c. Do not add the fuel near an open flame, welding arc or when the engine is running. Stop the engine and allow it to cool before refueling to prevent spilled fuel from vaporizing on contact with hot engine parts and igniting. Do not spill fuel when filling tank. If fuel is spilled, wipe it up and do not start engine until fumes have been eliminated.



- d. Keep all equipment safety guards, covers and devices in position and in good repair. Keep hands, hair, clothing and tools away from V-belts, gears, fans and all other moving parts when starting, operating or repairing equipment.
- e. In some cases it may be necessary to remove safety guards to perform required maintenance. Remove guards only when necessary and replace them when the maintenance requiring their removal is complete. Always use the greatest care when working near moving parts.
- f. Do not put your hands near the engine fan. Do not attempt to override the governor or idler by pushing on the throttle control rods while the engine is running.
- g. To prevent accidentally starting gasoline engines while turning the engine or welding generator during maintenance work, disconnect the spark plug wires, distributor cap or magneto wire as appropriate.



- h. To avoid scalding, do not remove the radiator pressure cap when the engine is hot.

HAVE ALL INSTALLATION, OPERATION, MAINTENANCE AND REPAIR WORK performed by qualified people.

For more detailed information, it is strongly recommended that you purchase a copy of “Safety in Welding & Cutting — ANSI Standard Z49.1” from the American Welding Society, P.O. Box 351040, Miami, Florida 33135.



PRODUCT DESCRIPTION

Complete semiautomatic arc welder with constant voltage transformer/rectifier DC arc welding power source, constant speed wire feeder and wire reel stand, all in a common housing. Includes a voltmeter and a 15' work cable with

work clamp. Also includes one set of drive rolls and guide tubes for wire size specified. For single phase input power. Units having an input voltage under 250 volts include a 6' input cable, plug and receptacle. Units with input voltages above 250 volts have only a 6' input cable.

INSTALLATION

⚠ WARNING	
	HIGH VOLTAGE can kill.
	<ul style="list-style-type: none"> • Do not operate with covers removed. • Disconnect input power before servicing. • Do not touch electrically live parts.
	MOVING PARTS can injure.
	<ul style="list-style-type: none"> • Keep away from moving parts.
<ul style="list-style-type: none"> • Only qualified personnel should install, use or service this equipment. 	
⚠ WARNING	
	FALLING EQUIPMENT can cause injury.
	<ul style="list-style-type: none"> • Do not lift this machine using lift bale if it is equipped with a heavy accessory such as trailer or gas cylinder. • Lift only with equipment of adequate lifting capacity. • Be sure machine is stable when lifting.

MECHANICAL INSTALLATION

Location — Locate the welder in a dry location where there is free circulation of clean air into the louvers in the back and out the front and bottom. A location that minimizes the amount of smoke and dirt drawn into the louvers reduces the chance of dirt accumulation that can block air passages and cause overheating. A minimum of 12 inches of unrestricted space should be maintained between the back of the case or front panels and the nearest obstruction.

WIRE SIZE OR TYPE CONVERSION KITS

The SP-200-AB model comes with the drive roll kit for .023" thru .035" steel wire factory installed.

The SP-200 welder, as shipped from the factory, does not have the drive rolls or guide tubes installed. The drive roll kit for the electrode size specified on the order is shipped with the wire feed unit. The drive roll kit for .035" steel wire (which is also usable for .023" and .030" steel wire) is

T-15010-.035S, and the drive roll kit for .068" and .072" Innershield® flux cored wire is T-13355-³/₃₂". The drive roll kit for .062" Innershield flux-cored wire is T-13355-¹/₁₆". The .068"/.072" drive rolls and guide tubes are marked .068, ⁵/₆₄ and ³/₃₂" — DO NOT use the equipment for feeding ⁵/₆₄ or ³/₃₂" wire.

See "Optional Features Installation" for aluminum wire conversion kits.

Instructions to install the T-15010-.035S and T-13355-³/₃₂ drive roll kits on new machines, or replace them on used machines, are as follows:

- A. Loosen the idle roll tension screw (item 6) approximately 5 full turns or use a screwdriver between the idle roll arm and the gear box boss at point A to pry the idle arm out until the idle roll clears the drive roll.
- B. Remove hex head screw (item 1) and the drive roll clamping collar (item 2). (On new machines remove the tape and drive roll key from the collar.) Insert the key into the keyway of the output shaft.
- C. The .023/.035" drive roll is one piece and should be installed with the required groove up. The wire size being used can then be read on the top of the roll. The .068" Innershield drive roll is made up of two reversible drive rolls and a spacer. Wipe the drive roll and spacer (.068" only) surface clean. Wipe the output shaft and locating shoulder clean. Install the drive roll on the output shaft. The .068" drive roll is to be installed with the spacer between the two drive rolls.
- D. Install the drive roll clamping collar and hex head screw previously removed. Tighten hex head screw securely.
- E. Back out the two guide tube clamping set screws (item 4).
- F. Insert the outgoing guide (item 3) (the one with the plastic insert) into the front hole. The guide tube for .023 thru .035" wire has a non-symmetrical chisel end. Be certain the contour with the larger radius and the exposed oval opening for the wire faces the grooved drive roll. Push the guide tube back as far as it will go and tighten the clamping set screw. Insert the incoming guide tube (item 5) into the rear hole as far as it will go and tighten the clamping set screw. These set screws are dog points. When the two tubes are installed properly these dog points will lock into the annular grooves that are in each of the guide tubes.
- G. Tighten the idle roll tension screw (item 6) or remove the screwdriver used as a wedge in step A. The tension screw should normally be tightened until it bottoms and then backed out two turns for .068" and .072" Inner-

shield wire. For smaller wire sizes and aluminum wire, the tension screw should be loosened further. The setting depends upon type of wire, surface condition, lubrication and hardness. The optimum idle roll setting can be determined when there are wire stoppages. If the wire "bird nests" between the drive roll and the guide tube the idle roll spring pressure is set too high. When properly set, during a stoppage the drive rolls will slip and if the electrode is removed from the cable there will be a slight waviness in the electrode for about a foot beyond the slip marks on the electrode. If there is no waviness the pressure is set too low.

H. To change drive rolls and guide tubes for a different size, reverse the above procedure.

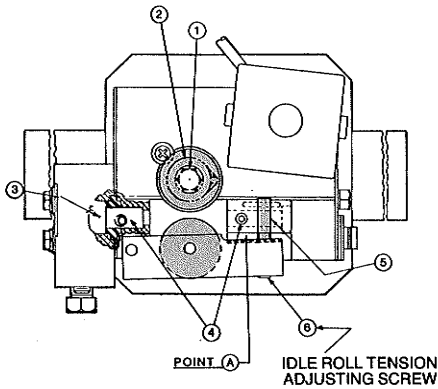

GUN AND CABLE ASSEMBLIES

GENERAL

The SP-200 may be used with various guns. Use the appropriate Lincoln gun and cable assembly for the electrode type (solid, cored or Innershield) and electrode size to be used.

GUN AND CABLE

A gun and cable assembly, suitable for the application, is to be provided with the proper connectors per the information below:

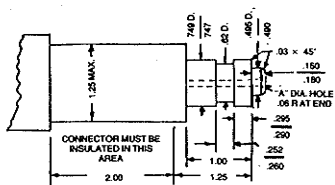

SP-150 CABLE CONNECTOR FOR .023-.035 WIRE

NOTE — CONNECTOR PART WITH 749/747 DIA. SHOULD BE MADE FROM BRASS IF IT IS TO BE PART OF THE WELDING CURRENT CARRYING CIRCUIT

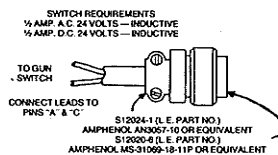

Wire Size	"A" Dia. Hole To Be Concentric To 749/747 Dia. Within .008 F.I.M.
.030 & .035	.055 (#54 Drill)
.023-.025	.047 (#3/64 Drill)
.045 cored	.062 (#1/16 Drill)

1. Lay the cable out straight. Insert the connector on the welding conductor cable thru the large hole in the front panel of the SP-200 and into the brass conductor block on the front of the wire drive.

Note that the connector handle is to be angled down approximately 15°. Make sure the connector is all the way in the conductor block and hand tighten the gun clamping screw securely. Keep this connection clean and bright.

2. Connect the gun trigger control cable polarized Amphenol plug (Amphenol MS-3106-18-11P or equivalent) into the mating receptacle on front of the wire drive unit.

CAUTION: The gun trigger switch connected to the gun trigger control cable must be a normally open, momentary switch. The terminals of the switch must be insulated from the welding circuit. Damage to the SP-200 will result if this switch is common to any electrical circuit other than the SP-200 trigger circuit.

3. Connect the 3/16 I.D. gas hose from the gun to the barbed gas outlet fitting supplied for installation on the front of the SP-200. This fitting can be easily removed by loosening the union nut.

OPTIONAL FEATURES INSTALLATION

WIRE DRIVE CONVERSION KITS FOR ALUMINUM ELECTRODE

For .035" aluminum wire — T-14629-.035A
 For 3/64" aluminum wire — T-14629-3/64A

Install per the S-17083 instruction sheet shipped with the kit.

INNERSHIELD® GUNS

Lincoln's K-126 Squirtgun is used for welding with .068" or .072" Innershield electrode. Install the insulated nozzle extension (or thread protector) and the nozzle contact tip for the stickout and electrode size being used. (The T-14050-.072 contact tip for .068 and .072 electrode and the T-14050-1/16 for .062 electrode must be ordered separately.)

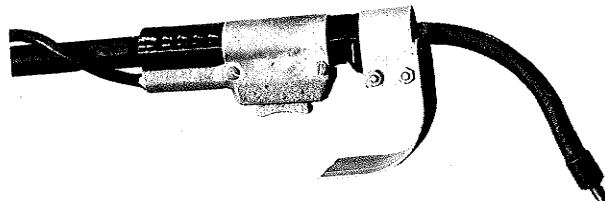

For locations where smoke accumulation is a problem and conventional exhaust systems are ineffective, a K-309 smoke removal type Innershield gun and Linconditioner vacuum unit can be used. Instructions are shipped with the equipment.

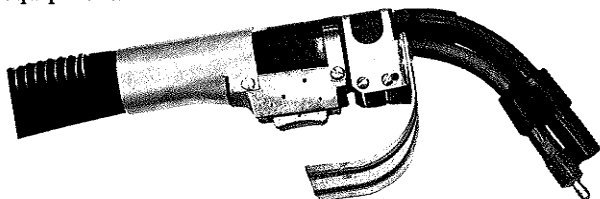

CAUTION: The gun trigger switch connected to the gun trigger control cable must be an *electrically isolated*, normally open, momentary switch. Damage to the SP-200 may result if this switch is common to any electrical circuits other than the SP-200 trigger circuit. All Lincoln gun trigger switches are of this type.

ASSEMBLY OF GUN CABLE TO SP-200

Lay the cable out straight. Insert the connector on the welding conductor cable thru the large hole in the front panel of the SP-200 and into the brass block on the front of the gear box. Make sure it is all the way in and tighten the locking screw with a 3/16" hex Allen wrench. Keep this connection clean and bright. Connect the gun trigger control cable polarized amphenol plug into the mating receptacle on front of the wire drive unit.

⚠ WARNING

- Keep cylinder upright and chained to support.
- Keep cylinder away from areas where it may be damaged.
- Never lift welder with cylinder attached.
- Never allow welding electrode to touch cylinder.
- Keep cylinder away from welding or other live electrical circuits.

GAS CYLINDERS may explode if damaged.

ELECTRICAL INSTALLATION

INPUT POWER AND GROUNDING CONNECTIONS

Before starting the installation, check with the local power company if there is any question about whether your power supply is adequate for the voltage, amperes, phase and frequency specified on the welder nameplate. Also be sure the planned installation will meet the National Electrical Code and local code requirements. This welder may be operated from a single phase line or from one phase of a two or three phase line.

The 208/230 volt 60 Hz and 200/220, 380/415 volt 50 Hz models are shipped connected for the higher voltage. If the welder is to be operated on the lower voltage it must be reconnected according to the instructions (S-16962) on the inside of the removable panel near the rear on the left side.

⚠ WARNING

ELECTRIC SHOCK can kill.

- Do not touch electrically live parts such as output terminals or internal wiring

WARNING: Make certain that the power cord is unplugged before removing the two screws that hold the access panel in place.

The 208/230 volt 60 Hz and 200/220 volt 50 Hz models are shipped with the input cable and plug connected to the welder. A matching receptacle is supplied with the machine. Mount the receptacle in a suitable location using the screws provided. Be sure it can be reached by the plug on the input cable attached to the welder. Mount with the grounding terminal at the top to allow the power cable to hang down without bending.

NOTE: Machines built for power lines over 250 volts are not equipped with a plug installed on the input cable, nor a receptacle. The instructions for wiring these machines are pasted on the inside of the removable panel near the rear on the left side. Use fuses and input wire sizes suitable for the input amperes specified on the nameplate.

Using the following instructions have a qualified electrician connect the receptacle to the input power lines and the system ground per the National Electrical Code and any applicable local codes. See the table for proper wire sizes. For long runs over 100', larger copper wires should be used in the conduit. Fuse the two hot lines with super lag type fuses as shown in the following diagram. The center contact in the receptacle is for the grounding connection. A green wire in the input cable connects this contact to the frame of the welder. This ensures proper grounding of the welder frame when the welder plug is inserted into the receptacle.

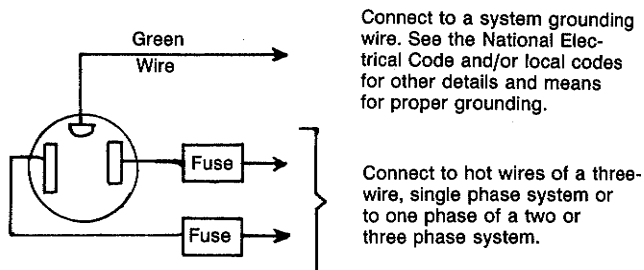

Input Voltage	Hertz	Type 75°C Wire in Conduit, Copper Cond. AWG Size		Grounding Wire Copper Cond. AWG Size	Fuse Size (Super Lag)
		Runs to 100'	Runs over 100'		
208/230	60	8	6	10	60
200/220	50	8	6	10	60
380/415	50	10	8	10	30
460	60	10	8	10	30

OUTPUT CONNECTIONS

WARNING

ELECTRIC SHOCK can kill.



- Do not touch electrically live parts such as output terminals or internal wiring

WARNING: Turn the welder off before making output connections.

Connect the electrode cable coming through the case front from the wire feed section to either the positive (+) or negative (-) output stud, as determined by the welding process used. Innershield electrode (.062 and .068 dia.) use electrode negative polarity and L-50 solid wire (.030/.035" dia.) and .045 cored Outershield™ normally uses electrode positive polarity. Polarity *must* be correct for the process used. Connect the 15 foot #2 work cable to the output stud of the opposite polarity of the electrode cable. Tighten both nuts with a wrench.

To attach clamp to work cable, insert work cable through strain relief hole in work clamp and fasten securely with bolt and nut provided.

AUXILIARY EQUIPMENT CIRCUIT

The power for 115 volt AC auxiliary control equipment such as a solenoid valve can be obtained from 1/4" quick-connect terminals located inside the wire feed section. An insulation flap covers the two terminals. The current draw from this circuit must *not* exceed 1/4 (.25) ampere. The circuit is "hot" only when the gun trigger circuit is closed.

OPTIONAL FEATURES INSTALLATION

K-162-H 2" O.D. Spindle Kit — To mount the spindle kit, remove wire feed unit from case. Remove the shaft for the standard 50-60 pound wire coils from the mounting framework. Install the spindle per the instructions shipped with the kit.

Adjust the brake tension screw (see Operation Sec.) on the spindle as needed. (2" spindle is factory installed on SP-200-AB.)

K-363-P 30 lb Readi-Reel Adapter — Plastic hub for mounting 22-30 lb Readi-Reels on a 2" O.D. spindle. (Factory installed on SP-200-AB.)

K-438 60 lb Readi-Reel Adapter — Required to feed 50-60 lb Readi-Reel coils from K-162-H Spindle Kits. Instructions are included with the adapter.

NOTE: Not for use on SP-200-AB.

K-435 Spindle Adapter for 14 lb Coils — Provides for mounting 14 lb Innershield® coils on 2" O.D. spindles.

K-340-P Solenoid-Valve Kit — Install per the M-14889 instructions shipped with the kit. (Factory installed on SP-200-AB.)

K-341 Stitch Timer/Spot Timer/Burnback Kit — Install per the S-16982 instructions shipped with the kit. (Factory installed on SP-200-AB.)

K-342-25 Foot Wire Feeder Extension Assembly — Install per the S-16984 instructions shipped with the kit.

K-343-25 and K-343-50, 25 or 50 Foot Power Input Cable with Plug — Install per the M-14253 instructions shipped with the kit.

K-840 Gas Cylinder Mounting & Undercarriage — Install per the S-18113 instruction sheet shipped with the kit.

K-778 Undercarriage — Install per the T-14156 instruction sheet shipped with the kit.

Wire Drive Conversion Kits for Aluminum Electrode (Use harder aluminum alloys for better feedability.)

For .035" aluminum wire — T-14629-035A

For 3/64" aluminum wire — T-14629-3/64A

Install per the S-17083 instruction sheet shipped with the kit.

OPERATION

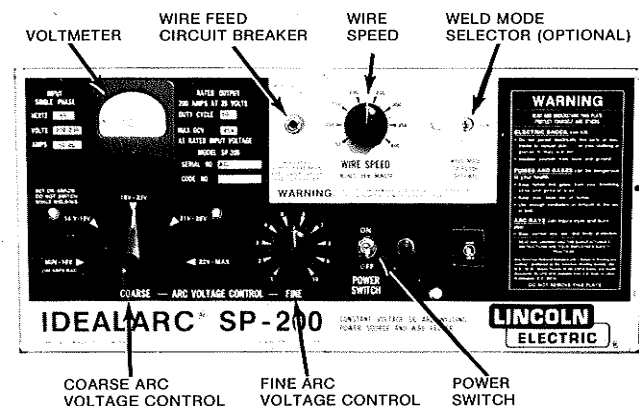

A. Description of Controls

1. **Power Switch** — Turns machine on and off.
2. **Coarse Arc Voltage Control** — A five position selector switch which changes the arc voltage by approximately 4 volts when switched from one position to the next. (The minimum range is for solid wire only.)
3. **Fine Arc Voltage Control** — A continuously adjustable rheostat that gives approximately 5 volts of arc voltage control. This control gives overlapping ranges on each of the five coarse voltage control settings when using solid wire procedures, and

it gives overlapping ranges on each of the upper four coarse arc voltage control settings when using Innershield procedures. The Fine Arc Voltage Control is effective only while welding; it does not control the open circuit voltage.

4. **Voltmeter** — This meter reads the voltage at the output studs of the machine. The actual arc voltage at the workpiece is slightly lower due to the drop in the gun conductor cable and in the work cable.
5. **Wire Speed** — Controls the wire speed from 50 to 400 inches per minute. The control can be preset on the dial plate to the desired wire speed and the actual wire speed while welding will be very close to that value.
6. **Wire Feed Circuit Breaker** — This control has a dual function. It can be used as an on-off switch to completely stop wire feed and it functions as an overload circuit breaker. When the button is completely black the circuit breaker is closed and wire will feed when the gun trigger is pressed. Press the button once to turn off the wire feed. A white band will appear on the button. To turn the wire feed back on, press the button again. (See Maintenance Section.)

B. Polarity

Check to see that the cable coming from the conductor block on the wire feed unit goes to the output stud that is of the polarity required for the process that is to be used. (Refer to "Output Connections", Page 6.)

C. To Start the Welder

Turn the "Power Switch" to "ON". This lights the red pilot light next to the switch and starts the cooling fan. Operate the gun trigger for welder output and to energize the wire feed motor.

D. Wire Reel Loading (30, 50 and 60 Pound Coils)

1. Open the side door for access to the wire feed compartment. To remove the wire reel from its shaft, grasp the spring loaded knob and pull it out. This straightens the knob so it seats into the shaft when released. Remove the reel.
2. Lay the reel flat on the floor, loosen the spinner nut and remove the cover plate.
3. Before cutting the tie wires, place the coil of electrode on the reel so it unwinds as the reel rotates clockwise.
 - a. Be sure the coil is placed so the spring loaded arms will not interfere with the later removal of the coil tie wires. (See photo.)
 - b. When loading .030 and .035" Lincoln electrode, be certain the coil is placed on the reel so the spring loaded arms are at the center of the slots in the cardboard coil liner. This provides the positive compression of the coil needed for trouble-free wire feeding. (See photo.)

- c. Put the cover plate on the reel so the four arms of the cover straddle the spring loaded arms of the reel proper.

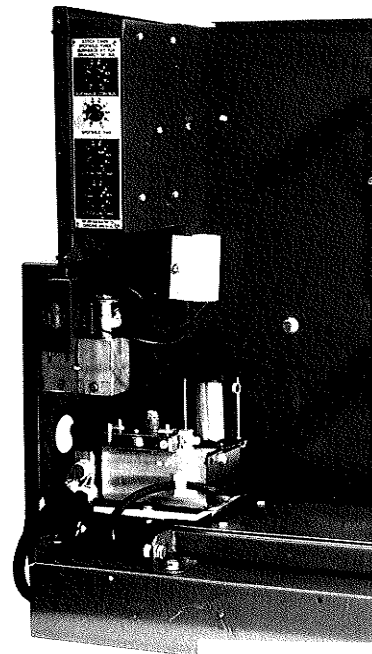

WIRE FEED COMPARTMENT

Shown with optional K-341 Timer Kit and with top of case removed.

4. Tighten the cover as much as possible by hand. DO NOT hammer on the spinner nut arms.

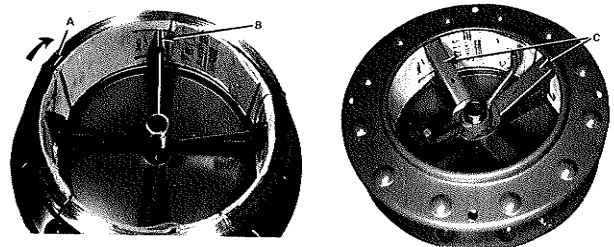

5. Cut and remove *only* the tie wire holding the free end of the coil. Insert the free end into one of the holes in the cover and secure it by bending it back. Cut and remove the remaining tie wires.

CAUTION: Always be sure the free end of the coil is securely held while the tie wires are being cut and until the wire is feeding through the drive rolls. Failure to do this will result in "back-lashing" of the coil, which may tangle the wire. A tangled coil will not feed so it must either be untangled or discarded.

6. Replace the reel on the wire feeder. Grasp the shaft knob, pull it out and swing it across the reel hub.
7. Turn the reel until the free end of the electrode is accessible. While tightly holding the electrode, cut off the bent end.

- Straighten the first six inches and cut off the first inch. Insert the free end through the incoming guide tube. Press the gun trigger and push the electrode into the drive roll. Inch the electrode through the gun. (If the electrode is not properly straightened, it may not feed or may not go into the outgoing guide tube causing a "birdnest".)

⚠ WARNING	
	ELECTRIC SHOCK can kill.
	<ul style="list-style-type: none"> Do not touch electrically live parts such as output terminals or internal wiring

WARNING: When inching, the electrode and drive mechanism are always "hot" to work and ground and remain "hot" several seconds after the gun trigger is released.

E. Wire Reel Brake, 30, 50 and 60 Pound Reel Mounting

- The mount for standard 30, 50 and 60 pound electrode coils includes a two position brake assembly. Generally the brake should be at the inner position (nearest to the wire reel shaft) for wire feed speeds below 400 in/min. If excessive wire reel overrun is encountered, move the brake to the outer position.
- To adjust the brake position, remove the wire reel. Pull the cotter pin that holds the brake shoe to the arm, move the shoe and replace the cotter pin. Do not bend the cotter pin — it is held in place by a friction fit.

F. Wire Reel Loading — Readi-Reels® and Spools

To mount a 30 lb Readi-Reel package using the molded plastic K-363-P type adapter:

- Rotate the spindle and adapter so the retaining spring is at the 12 o'clock position.
- Position the Readi-Reel so that it will rotate in a *clockwise* direction when feeding (wire is to be dereeled from *top* of coil).
- Set one of the Readi-Reel inside cage wires on the slot in the retaining spring tab.
- Lower the Readi-Reel to depress the retaining spring and align the other inside cage wire with the grooves in the molded adapter.
- Slide cage all the way onto the adapter until the retaining spring "pops up" fully.

To remove the Readi-Reel from Adapter, depress retaining spring tab with thumb while pulling the Readi-Reel cage from the molded adapter with both hands. Do not remove adapter from spindle.

⚠ WARNING	
	ELECTRIC SHOCK can kill.
	<ul style="list-style-type: none"> Do not touch electrically live parts such as output terminals or internal wiring

WARNING: Check to be sure the retaining spring has fully returned to the locking position and has *securely* locked the Readi-Reel cage in place. Retaining spring must rest on the cage not the welding electrode.

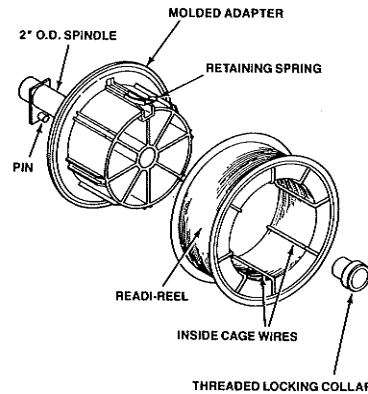

To mount a 30 lb Readi-Reel package using the formed sheet metal K-363 (obsolete) type adapters:



- Remove the locking collar and remove the outside Readi-Reel adapter arm.
- Engage the inside Readi-Reel adapter arm in the brake driving pin and rotate the spindle until the inside adapter arm is in the vertical position.
- Set the Readi-Reel on the adapter arm. The Readi-Reel must be installed so that it will rotate in a *clockwise* direction when feeding (wire is dereeled from the top of the coil).
- The outside adapter arm is then to be placed on the spindle at an angle of 90° from the inside adapter and the locking collar installed. Tighten the locking collar securely.

To mount 10 to 30 lb spools:

- Remove the locking collar and the Readi-Reel adapter shipped on the 2 inch dia. spindle. (Readi-Reel adapter is not required. Use S-18221 Spindle Adapter for 8" O.D. spools.)
- Place the spool on the spindle making certain the brake driving pin enters one of the holes in the back side of the spool. Be certain the wire comes off the reel in a clockwise direction when dereeled from the top of the coil.
- Replace and tighten the locking collar.

To feed the electrode, turn the Readi-Reel or spool until

the free end of the electrode is accessible. While tightly holding the electrode, cut off the bent end. Straighten the first six inches and cut off the first inch. Insert the free end through the incoming guide tube. Press the gun trigger and push the electrode into the drive roll. Inch the electrode through the gun. (If the electrode is not properly straightened, it may not feed or may not go into the outgoing guide tube causing a "birdnest".) Adjust the brake tension with the hex head screw or thumb screw on the spindle hub, until the reel turns freely but with little or no overrun when wire feeding is stopped. Make certain that the wire does not come loose on the spool or reel when feeding is stopped.

 WARNING	
	ELECTRIC SHOCK can kill.
	<ul style="list-style-type: none"> • Do not touch electrically live parts such as output terminals or internal wiring
<p>WARNING: When inching, the electrode and drive mechanism are always "hot" to work and ground and remain "hot" several seconds after the gun trigger is released.</p>	

G. Wire Reel Changing

1. At the end of a coil, remove the last of the old electrode by laying the gun and cable out straight and pulling the electrode end out through the nozzle. Load a new reel of electrode per the preceding instructions.

H. Optional K-341 Stitch Timer/Spot Timer/Burnback Kit (Std. on SP-200-AB model)

The optional K-341 Timer Kit consists of a sheet metal case which contains the timer printed circuit board, four adjustable controls and a three position mode switch. The timer kit is installed in the wire feed section of the SP-200 on the back side of the case front per the instruction sheet shipped with the kit. When installed, the three position "Weld Mode Selector" switch projects through the SP-200 front nameplate next to the "Wire Speed" control, allowing easy access to the switch. The four timer control knobs are located on the timer kit case panel, which is inside the wire feed section above the wire feed motor/gearbox assembly. To gain access to the timer control knobs on the inner panel, open the door to the wire feed section.

The three position "Weld Mode Selector" switch is used to select the following modes of operation:

1. The up position is for the "SPOT" welding mode which gives single, timed welds. To start the weld, close and hold the gun trigger switch; the weld will start and then automatically stop after a timed interval. To produce another timed weld, release and re-close and hold the gun trigger. The time of the

weld is adjustable from 1/2 to 3 seconds using the "SPOTWELD TIME" control on the inner panel. (Timer dials show increments from 1 to 10. They are *not* calibrated in seconds.) Since the timing starts when the gun trigger is pressed, for consistent welds it is important that the electrode is either *lightly* touching or very near the work when the trigger is pressed.

2. The center position of the "Weld Mode Selector" switch is for the "SEAM" welding mode, which is normal continuous welding. The weld starts when the gun trigger is closed and stops when the gun trigger is released.
3. The down position of the "Weld Mode Selector" switch is for the "STITCH" welding mode. This mode gives repeated timed welds and time "off" periods for as long as the gun trigger is held closed. The "on" and "off" time intervals are independently adjustable from 1/2 to 2 seconds using the "STITCH OFF TIME" and "STITCH ON TIME" controls located on the inner panel. (Timer dials show increments from 1 to 10. They are *not* calibrated in seconds.) The electrode and auxiliary power terminals stay energized during the "off" time; only the wire feed stops. This mode, which minimizes heat input, is very useful when welding light gauge sheet metal 18 thru 24 gauge (.048" - .024"), where warpage and/or burn through would otherwise be a problem. The controls and travel speed along the seam should be set to give a series of overlapping welds in which the glow is allowed to almost disappear from the previous weld before the next weld begins. Start with the "OFF TIME" control set at 2 on the dial and the "ON TIME" control set at about 2.5 on the dial. Re-adjust the controls as required to give the best results.

The "BURNBACK CONTROL", which is the top control on the inner panel, gives an adjustable burnback of the electrode to prevent it from sticking in the puddle at the end of a weld. Burnback is accomplished by providing an adjustable delay of up to 1/3 of a second after the gun trigger is released before the welding power shuts off. The control should be set at minimum (1 on the dial) and increased only if the electrode sticks in the puddle. Increasing the control setting should normally be required only at wire feed speeds above 250 inches per minute. The burnback control circuit is effective in all three modes of operation as follows:

1. In the "SPOT" welding mode, the burnback delay action automatically occurs at the end of the timed weld.
2. In the "SEAM" welding mode, the burnback delay action occurs when the gun trigger is released.
3. In the "STITCH" welding mode, the burnback delay action occurs if the gun trigger is released during an "ON" cycle.

I. Test Weld

1. Set the "Coarse" voltage selector switch knob to the voltage range desired.
2. Set the "Wire Speed" knob to the speed desired.
3. Set up a test plate and attach the work lead to it.
4. If a Gas Metal Arc process is being used, make any other required gas shielding adjustments for the process.
5. Inch the electrode through the gun and then cut the end off so that the stickout is approximately $\frac{3}{4}$ " for Innershield electrode. For .030 or .035" steel wire, cut the end of the electrode within $\frac{1}{4}$ " of the gas nozzle cone.
6. When using open arc processes, it is necessary to use correct eye, head and body protection.
7. Place the gun into welding position, with the end of the electrode approximately $\frac{1}{8}$ of an inch above the surface of the workpiece and pull the gun trigger. As the weld is being made, observe the voltmeter reading and adjust the "fine" voltage control knob to the desired value. If it is necessary to change the "coarse" voltage selector switch, stop welding before doing so.

CAUTION: DO NOT turn the coarse voltage selector switch while welding since this will damage it.

8. To stop welding, release the gun trigger and lift the gun from the work. The wire feed motor stops and the welding circuit is de-energized after the trigger is released. If a solenoid is connected to the auxiliary power terminals, it is de-energized when the trigger is released.



Refer to L-6591, "SP-200 Welding Procedures", at back of manual for further instructions.

J. Output Rating

The maximum rated output for the SP-200 and SP-200-AB, 60 Hz model, is 200 amps, 26 volts at a 60% duty cycle.⁽¹⁾ Duty cycle is based on a 10 minute period. Therefore, the welder can be operated for 6 minutes out of every 10 minute period without overheating.

⁽¹⁾ For 50 Hz models, rated duty cycle is 50%.

MAINTENANCE

 WARNING	
	ELECTRIC SHOCK can kill.
	<ul style="list-style-type: none">• Do not touch electrically live parts such as output terminals or internal wiring

WARNING: Have a qualified electrician do the maintenance and troubleshooting work. Turn the input power off using the disconnect switch at the fuse box before working inside the machine. Unplug power cable if it is connected to a receptacle.

A. General Maintenance

1. Whenever routine maintenance is performed on this machine — or at least yearly — inspect all nameplates and labels for legibility. Replace those which are no longer clear. Refer to the parts list for the replacement item number.
2. The fan motor has sealed ball bearings which require no service.
3. In extremely dusty locations, dirt may clog the air passages causing the welder to run hot. Blow dirt out of the welder at regular intervals.

B. Welding Power Overload Protection

The SP-200 has a built-in protective thermostat that responds to excessive temperature. It opens the input contactor if the machine exceeds the maximum safe operating temperature because of a frequent overload, or high room temperature plus overload. The thermostat automatically resets when the temperature reaches a safe operating level.

C. Wire Feed Circuit Breaker

The circuit breaker to the left of the "Wire Speed" control normally trips only when an overload occurs because of excessive loading in the wire feed cable, a defective wire feed motor, or a defective control component. The reset button gives a visual indication when the circuit breaker is tripped. After allowing a minute for cooling, push the reset button. If it trips again, be sure the wire feed cable is clean and that the cable and tip are the proper size for the wire diameter being fed. If it still trips, it may be caused by a defective electrical component. Pressing the untripped circuit breaker once turns off the wire feed circuit. Pressing it again turns it back on.

D. Wire Drive Motor and Gear Box

Every year inspect the gear box and paint the gear teeth with a moly-disulfide filled grease.

Every six months check the motor brushes. Replace them if they are less than 1/4" long.

E. Drive Rolls and Guide Tubes

After every coil of wire inspect the drive roll section. Clean it as necessary. Do not use solvents for cleaning the idle roll because it may wash the lubricant out of the bearing. The drive roll and guide tubes are stamped with the wire sizes they will feed. If a wire size other than that stamped on the roll is used, the rolls and guide tubes must be changed.

The drive roll for .068" Innershield and .045 cored Outershield™ has a double set of teeth so they can be reversed for additional life. Between the two .068 knurled rolls is a shim washer which limits the damage to the electrode if wire feeding problems occur. See Mechanical Installation for roll changing instructions.

The drive roll for .023 thru .035" diameter electrode is a solid roll with two smooth v-grooves; one for .023-.025" and one for .030-.035". See Mechanical Installation for proper mounting for the wire size being used.

F. Wire Reel Mounting, 30, 50 and 60 Pound Coils

To prolong the life of the wire reel shaft, periodically coat it with a thin layer of grease. If the brake shoe wears down to the rivet head, replace the brake shoe assembly.

G. Gun and Cable Maintenance

1. Gun Cable

A dirty gun cable can cause rough and erratic wire feeding; therefore, the cable liner must be cleaned periodically.

Remove the cable from the wire feeder. Lay it out straight on the floor. Remove the contact tip from the gun. Using an air hose and only partial pressure, gently blow out the cable. Work the full length of the cable by bending it back and forth and then blow it out again. Repeat this procedure until no more dirt comes out.

2. Gun Nozzles: K-126 and K-309 Innershield® Squirt-guns

- a. Replace worn contact tips as required.
- b. Remove spatter from tip or extension guide after each ten minutes of arc time or as required.
- c. Replace worn spring liners in nozzles. The life of the liner can be doubled by rotating liner 180°. The liner can be pulled out the back end of the nozzle by wedging the blade of a small screwdriver in the I.D. and pulling.
- d. Internal parts of nozzles can be removed and replaced by removing the internal hollow-lock set screw from the contact tip end of the nozzle with a 5/32 Allen wrench. The ceramic insert and retainer will normally fall out the end of the nozzle but if they do not, gently drive the spring

liner towards the outgoing end of the nozzle. When re-assembling nozzle, make certain the ceramic nozzle insert is placed next to the spring liner. The hollow-lock set screw is to be tightened to give the dimension of .38 as measured from the end of the nozzle to the hollow-lock set screw.

3. Gun Disassembly: K-126 and K-309 Innershield Squirtguns

- a. To remove the nozzle from the gun, loosen (do not remove) the 1/4-20 socket head screw with a 3/16 Allen wrench in the gun handle and pull the nozzle straight out. To reinstall, insert the nozzle into the gun handle. Push it in as far as possible and tighten the Allen head screw.
 - b. To disassemble Innershield Squirtguns, first loosen the screws which hold the heat shield in place. Remove the heat shield.
 - c. To disassemble the switch housing from all these guns, remove the four screws holding the saddle around the gun handle.
 - d. Then hold the housing with the cable toward the floor and look into the switch cavity. The tight side of the larger roll pins is to the right. Drive these pins to the left. They can be easily removed when they clear the right side of the casting.
 - e. Do not remove the smaller roll pins unless the trigger is being replaced. The height of the Z spring controls the operating point of the switch with respect to the trigger movement. Set the spring so the switch operates at about the mid-point of the trigger travel.
 - f. To remove the handle from the cable, slip the spatter shield out of the front of the handle. Loosen the 1/4-20 socket head screw in the side of the handle. Remove the snap ring. The handle and connection clamp can then be slipped off the cable.
4. For K-426-.045 GMA Gun Cable Maintenance refer to manual supplied with gun.

TROUBLESHOOTING

 <b style="font-size: 1.2em;">WARNING
ELECTRIC SHOCK can kill.
<ul style="list-style-type: none"> • Do not touch electrically live parts such as output terminals or internal wiring

WARNING: Disconnect input power before servicing. Only qualified personnel should install, use or service this equipment.

PROBLEM	POSSIBLE CAUSE	WHAT TO DO
1. Rough wire feeding or wire not feeding but drive rolls turning.	<ul style="list-style-type: none"> a. Gun cable kinked and/or twisted. b. Wire jammed in gun and cable. c. Incorrect drive rolls and guide tubes. d. Drive rolls loose. e. Gun cable dirty. f. Worn drive rolls. g. Electrode rusty and/or dirty. h. Worn nozzle liner. j. Partially flashed or melted contact tip. 	<ul style="list-style-type: none"> a. Inspect gun cable and replace if necessary. b. Remove wire from gun and cable — feed in new wire. Note any obstructions in gun and cable. Replace gun and cable if necessary. c. Check wire diameters stamped on drive rolls, wire guides and drive roll spacers for correct combination for wire being used. d. Remove, clean, install and tighten. e. Clean per Sec. G. f. Replace and/or reverse split drive roll type. g. Replace. h. Replace. j. Replace contact tip.
2. Variable or “hunting” arc.	<ul style="list-style-type: none"> a. Worn and/or melted contact tip. b. Worn or undersized work cable or poor work connection. c. Loose electrode connections. 	<ul style="list-style-type: none"> a. Replace tip — remove any spatter on end of tip. b. Inspect — repair or replace as necessary. c. Be sure electrode lead is tight, gun cable tight in wire feeder contact block, gun nozzle and gun tip tight.
3. Weld porosity, narrow and ropey bead, or electrode stubbing into plate when welding.	<ul style="list-style-type: none"> a. Dirty plate or improper procedures. 	<ul style="list-style-type: none"> a. See troubleshooting information in Bulletin N675, “Innershield Production Welding Guide” or Bulletin N677, “Innershield NR-211 Welding Guide”.
4. Wire feed circuit breaker trips while welding.	<ul style="list-style-type: none"> a. See Trouble 1 above. b. Defective wire feed motor or gearbox. 	<ul style="list-style-type: none"> a. Correct problem. b. Replace.
5. No wire feed or no control of wire feed. Contactor pulls in and voltmeter indicates voltage.	<ul style="list-style-type: none"> a. Wire feed circuit breaker in “off” position. b. Electrical component such as control printed circuit board has failed. Blown 10 amp fuse on control P.C. board indicates that the control P.C. board has probably failed. 	<ul style="list-style-type: none"> a. Re-set circuit breaker. b. Replace.
6. No wire feed and no output voltage. Pilot light indicates input power to SP-200.	<ul style="list-style-type: none"> a. The 4-prong connector going to the wire feed unit or the optional extension cable may not be making contact. b. If Timer Kit is not installed, jumper plug may not be properly seated in six cavity connector. c. Faulty gun trigger switch or damaged control cable connected to gun trigger. d. Gun trigger circuit not electrically isolated. e. Input power contactor has failed. f. Timer Kit may be defective. 	<ul style="list-style-type: none"> a. Correct problem. b. Make certain jumper plug is in place. (See K-341 Timer Kit installation instruction page.) c. Repair. d. If the gun trigger switch or control cable is in any way common to any electrical circuit other than the SP-200-24V trigger circuit, damage to the SP-200 can result. e. Replace. f. See Problem 8.

PROBLEM	POSSIBLE CAUSE	WHAT TO DO
7. Wire feed control but output voltage continuously present with gun trigger off.	<ul style="list-style-type: none"> a. Input power contactor has failed. b. Gun trigger circuit not electrically isolated. c. Timer Kit may be defective. 	<ul style="list-style-type: none"> a. Replace. b. If the gun trigger switch or control cable is in any way common to any electrical circuit other than the SP-200-24V trigger circuit, damage to the SP-200 can result. c. See Problem 8.
8. Suspected defective Timer Kit.	<ul style="list-style-type: none"> a. Improperly set machine. b. Connector plugs not making contact. c. Defective Timer. 	<ul style="list-style-type: none"> a. Check position of "Weld Mode Selector" switch. Be certain that it is set for the mode desired. b. Make certain that the plugs connecting to the Timer P.C. Board are properly seated. Check operation of machine. c. Remove Timer Kit (see K-341 installation instruction page) and install jumper plug which is stored at bottom of Timer Kit case. Check operation of machine. If problem is corrected, Timer Kit is defective. Replace.
9. Poor welding characteristics and/or cannot obtain full rated output of 200 amps at 26 volts.	<ul style="list-style-type: none"> a. Capacitor(s) in power source output circuit failed. A failure is indicated if the small vent plug on top of a capacitor is raised or blown out. 	<ul style="list-style-type: none"> a. Replace entire bank of capacitors. Do <i>not</i> replace individual capacitors. WARNING: The Liquid electrolyte in these capacitors is toxic. Avoid contact with any portion of your body. Clean up vented electrolyte using rubber gloves, and a water dampened cloth. Any electrolyte which gets on skin, clean with soap and water.

SP-200 SEQUENCE OF OPERATIONS

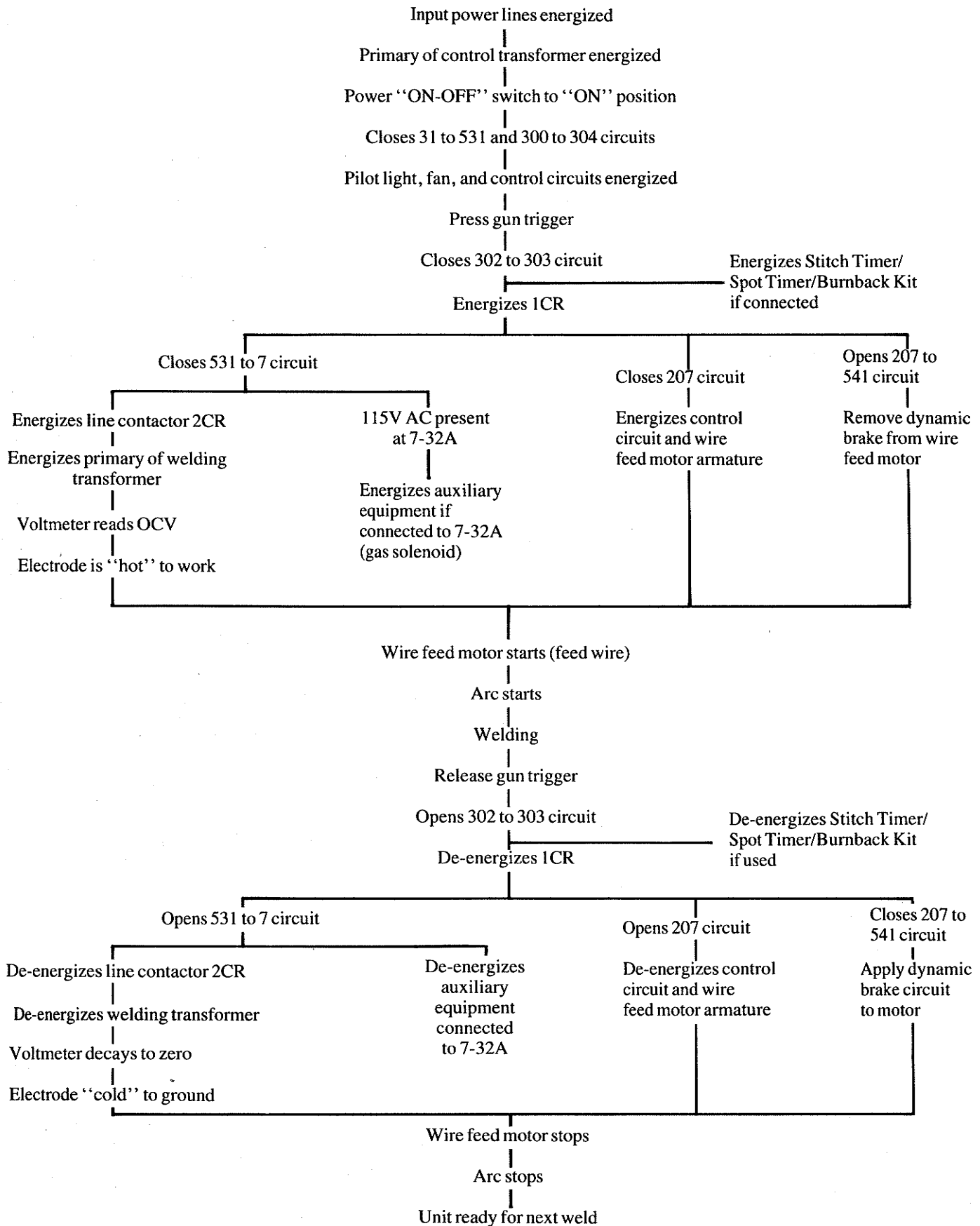

GENERAL ASSEMBLY (P-139-C)

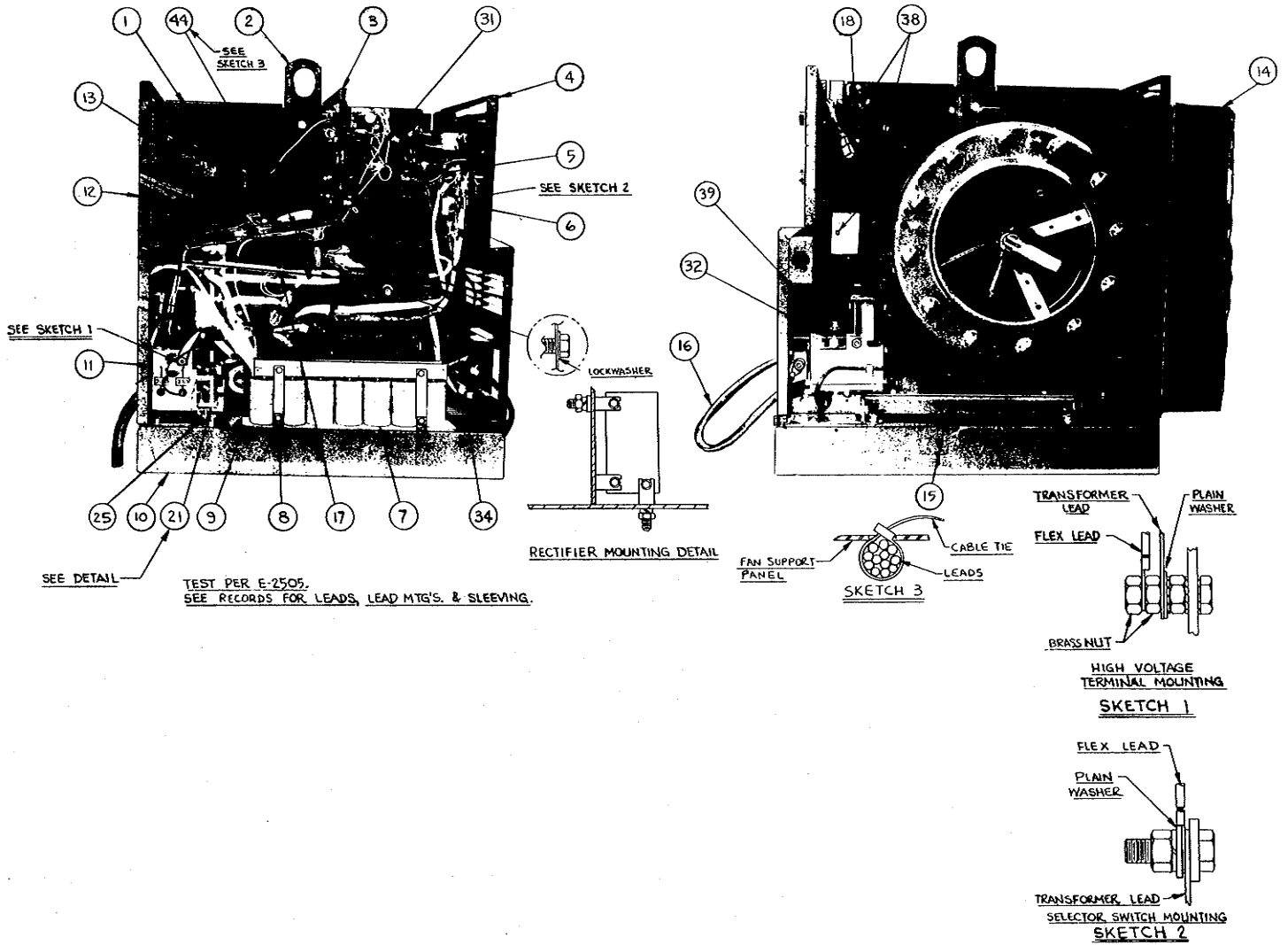

L-6574
10-15-82F

Parts List P-139-C.1

ITEM	PART NAME & DESCRIPTION	NO. REQ'D
1	Center Panel Assembly, Includes: Mag-Amp Assembly	1 1
2	Lift Bail Lift Bail Seal	1 1
3	Fan Support Panel Assembly See P-139-D	
4	Front Panel Assembly See P-139-E	
5	Choke Coil	1
6	Selector Switch	1
7	Selector Switch Handle Handle Screw Capacitor Assembly, Includes:	1 1 1
8	Capacitors Capacitor Jumper Capacitor Mounting Bracket	7 2 4
9	Capacitor Insulation	1
10	Base & Transformer Assembly, Includes: (Specify Single or Dual Voltage)	1
11	Base Transformer Assembly (Specify Voltage) Reconnect Panel Assembly See P-139-G	1 1
12	Case Back	1
13	Splash Shield Assembly	1
14	Case Door & Hinge Assembly	1
15	Wire Feed Unit See P-139-H	
16	Electrode Lead	1
17	Thermostat	1
18	Cable Hanger	1
19	Grommet Strip	1
21	Rectifier Assembly, Includes:	1
	Positive Diode	2
	Negative Diode	2
	Suppressor Assembly	1
	Rectifier Mtg. Bracket	3
	Items Not Illustrated:	
	Left Case Side	1
	Access Door (Left Case Side)	1
	Roof	1
	Ground Clamp	1
	Ground Cable	1
	Door Strike	1
	Lincoln Decal (Mounts on Door)	1
	Drive Roll & Guide Tube Kits See P-139-J	
	Auxiliary Transformer	1
	Timer By-Pass Jumper Plug	1
	SP-200 Procedure Sheet — Mounts Inside Case Door	1
	Optional Equipment: 10 to 25 Pound Spool Spindle Kit	
	Gas Solenoid Kit [Standard On (-AB) Models]	1
	Timer Kit [Standard On (-AB) Models]	1
	See P-139-F 25 Foot Wire Drive Extension Cable 25 Or 50 Foot Input Cables & Receptacle	1
	See P-139-G Undercarriage (Without Gas Cylinder Rack)	1
	Undercarriage (With Gas Cylinder Rack)	1

FAN SUPPORT PANEL

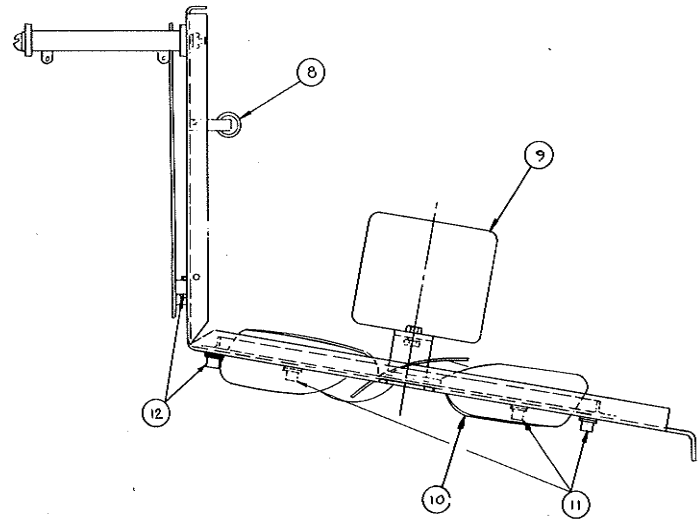
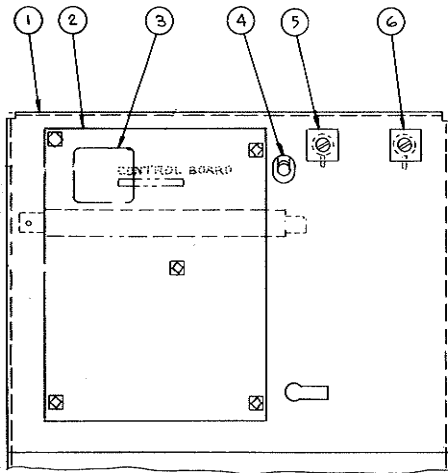

L-6459
6-29-84J

Parts List P-139-D

ITEM	PART NAME & DESCRIPTION	NO.. REQ'D
1	Fan Support Panel Assembly, Includes: Fan Support Panel	1 1
2	Control Printed Circuit Board (Does not include Item 3)	1
3	Relay	1
4	Grommet	1
5	Resistor Round Head Screw	1 1
6	Insulator Resistor Round Head Screw	2 1 1
8	Insulator Resistor	2 1
9	Fan Motor	1
10	Fan	1
11	Cable Hanger	3
12	Cable Hanger	2

FRONT PANEL

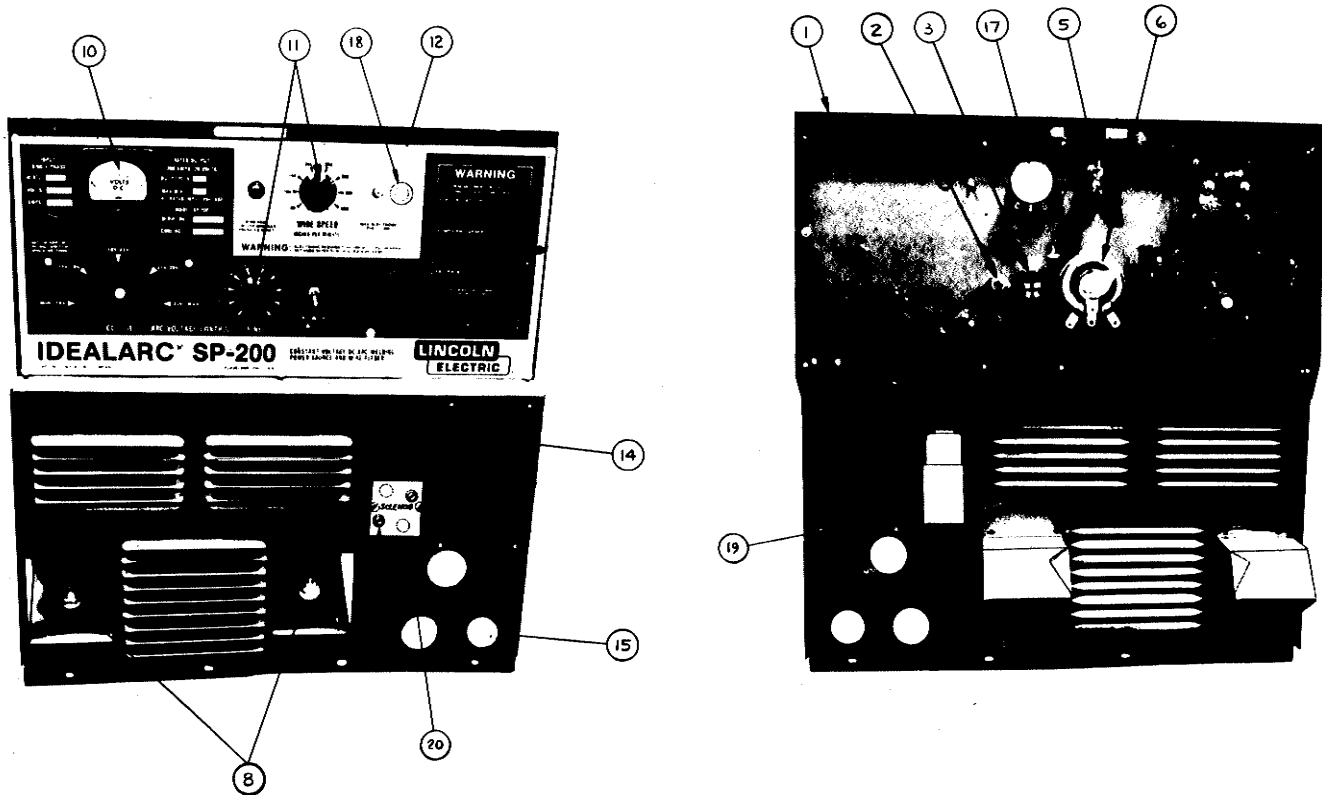

L-6460
3-15-85T

Parts List P-139-E

ITEM	PART NAME & DESCRIPTION	NO. REQ'D
1	Front Panel Assembly, Includes: Front Panel	1 1
2	Pilot Light	1
3	Power Switch	1
5	Circuit Breaker	1
6	Voltage Rheostat	1
8	Output Terminal Replacement Kit	2
10	Voltmeter	1
11	Knob	2
12	Nameplate	1
14	Warning Decal	1
15	Grommet	1
17	Wire Feed Rheostat	1
	Rheostat Insulation	1
18	Plug Button (Std. Machines Only)	1
19	Solenoid (- AB Machines Only)	1
20	Solenoid Nameplate (- AB Machines Only)	1

K-341 TIMER KIT

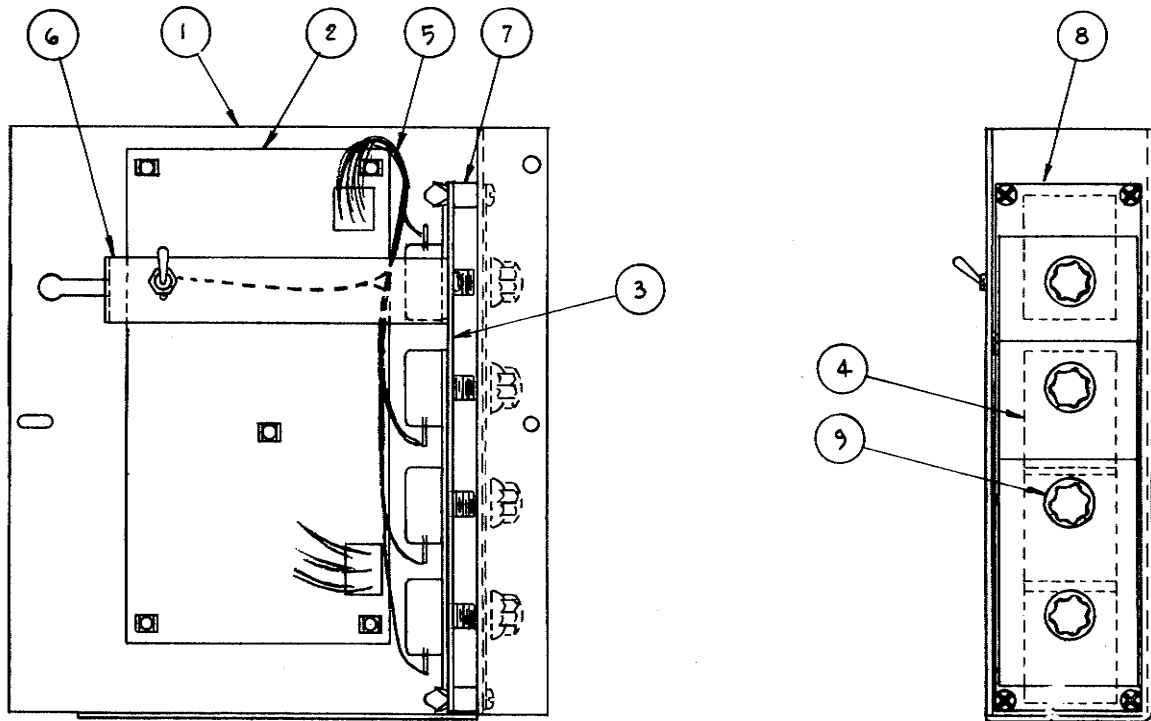

M-14139
10-2-81B

Parts List P-139-F

ITEM	PART NAME & DESCRIPTION	NO. REQ'D
1	Timer Assembly, Includes: Panel	1 1
2	Timer Printed Circuit Board	1
3	Inner Panel	1
4	Rheostat Insulation	4
5	Harness, Includes: Rheostats (R5, R11, R22 & R23) Mode Switch	1 4 1
6	Switch Bracket	1
7	Expansion Nut	4
8	Nameplate	1
9	Knob	4

RECONNECT PANEL

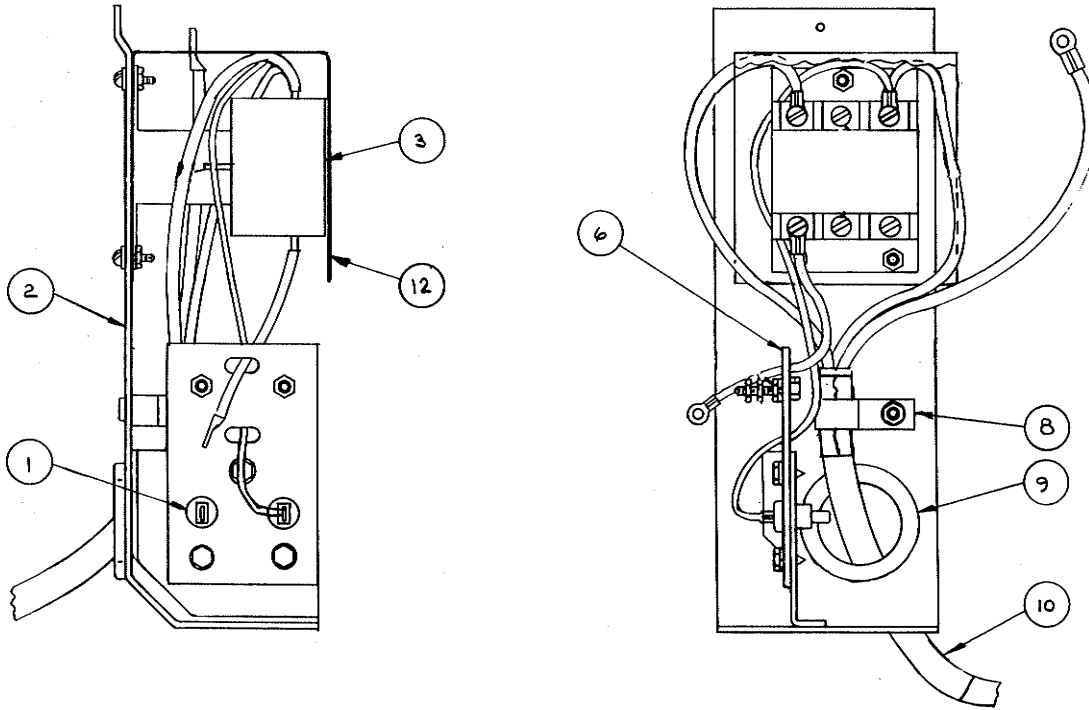

M-14109
5-10-85K

Parts List P-139-G

ITEM	PART NAME & DESCRIPTION	NO. REQ'D
1	Reconnect Panel Assembly, Includes: Terminal Bushing	1 2
2	Mounting Panel Assembly	1
3	Contactor	1
6	Reconnect Panel	1
8	Conduit Clip	1
9	Grommet	1
10	Input Cable (6 Ft.) (Standard)	1
	Above 250V Input Only	1
10	Input Cable (6 Ft.) (Standard) Below 250V	1
	Input Cable (25 Ft.) (Optional) Below 250V	1
	Input Cable (50 Ft.) (Optional)	1
12	Input Only Insulation	1 1
	Items Not Illustrated: Power Input Receptacle (Below 250V Input Only)	1

WIRE DRIVE ASSEMBLY

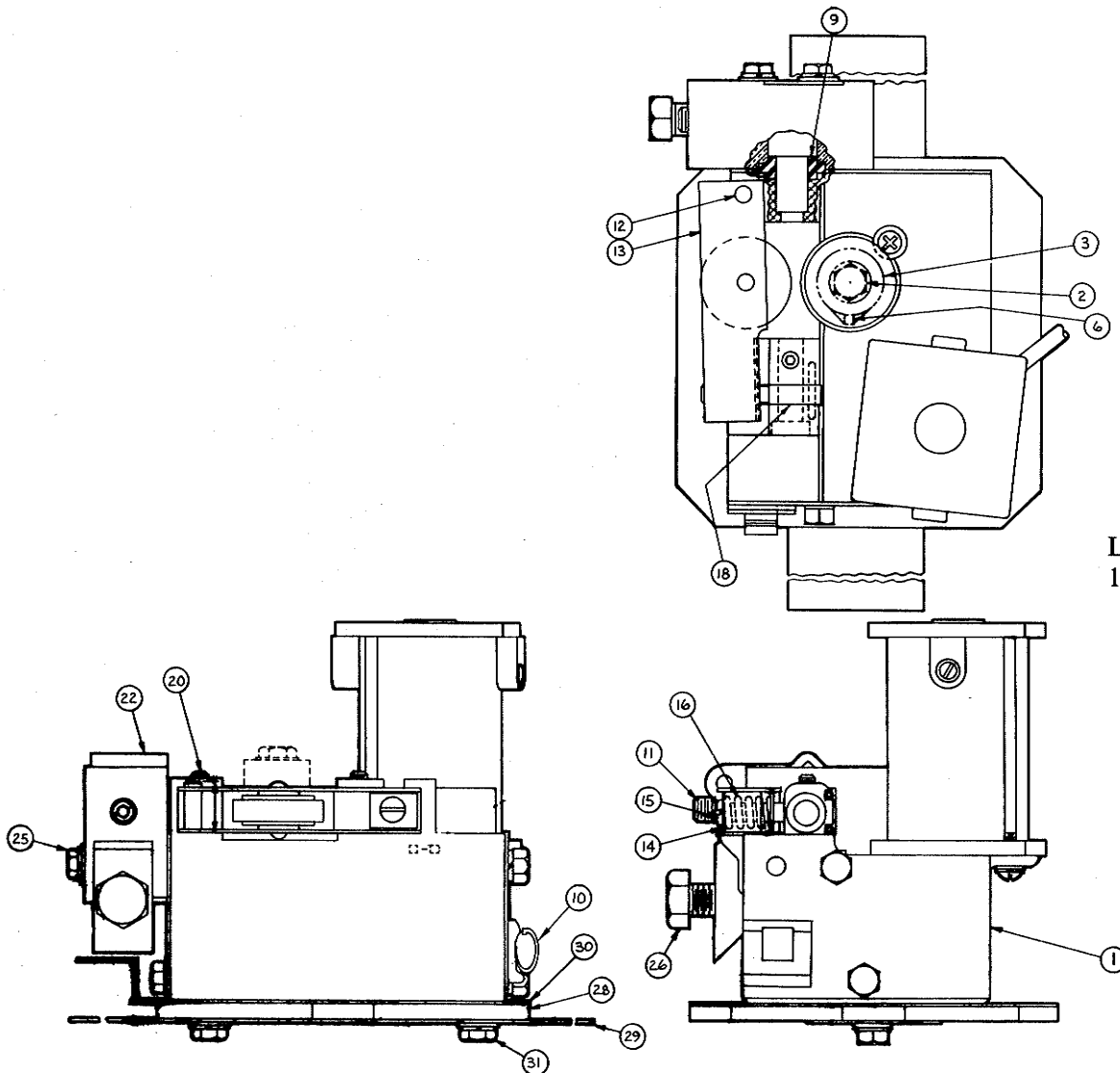

L-6422
12-19-85G

Parts List P-139-J.1

ITEM	PART NAME & DESCRIPTION	NO. REQ'D	ITEM	PART NAME & DESCRIPTION	NO. REQ'D
1	Wire Drive Assembly, Includes:	1	18	Idle Roll Pull Arm	1
	Gear Box Assembly, Includes:	1	20	Set Screw	2
2	Drive Motor	1	22	Conductor Block	1
3	Sems Screw	1	25	Hex Head Screw	2
6	Key	1		Lock Washer	2
9	Locator Bushing	1		Plain Washer	2
10	Cord Clip	1	26	Hex Head Screw	1
11	Set Screw	1		28	Gear Box Mounting Plate
12	Groove Pin	1	29		Gear Box Insulation
13	Idle Roll Assembly	1		30	Gear Box Insulation
14	Idle Roll Arm Bracket	1	31		Hex Head Screw
	Thread Cutting Screw	1		Plain Washer	2
16	Spring	1	Lock Washer		2
			Drive Roll and Guide Tube Kit (Specify wire size when ordering)		1

WIRE FEED UNIT

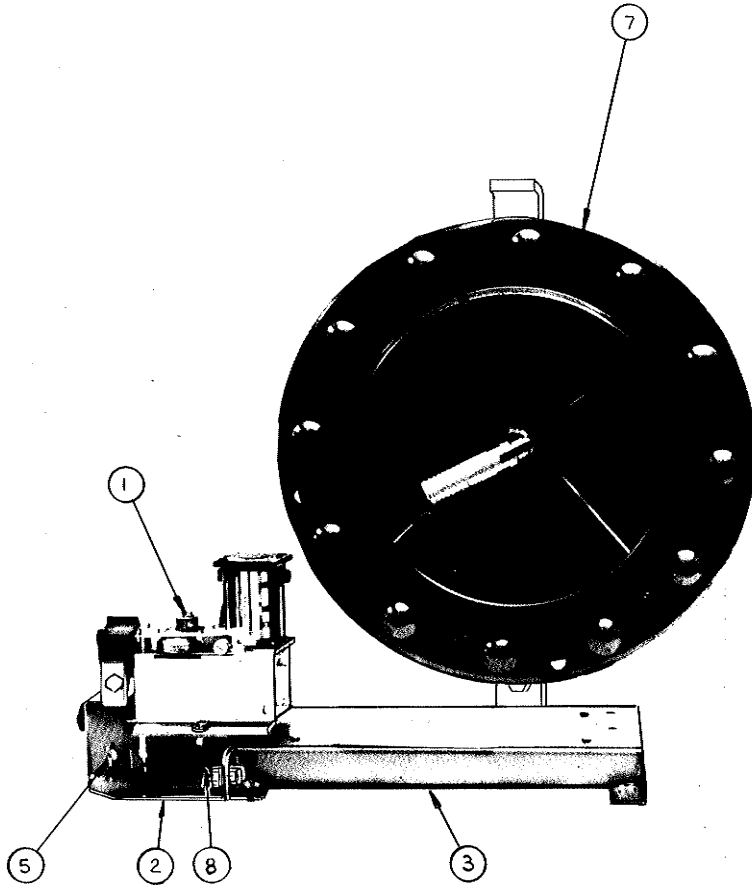

M-14165
3-23-84M

Parts List P-139-H

ITEM	PART NAME & DESCRIPTION	NO. REQ'D
1	Wire Feed Unit Assembly, Includes: Wire Drive Assembly See P-139-J	1
2	Gear Box Support Platform, Includes: Amphenol Receptacle 4 Pin Receptacle	1 1 1
3	Wire Reel Stand See P-125-N	
3	Wire Reel Support, Includes: Wire Reel Shaft See P-107-P Col. 3	1
5	Plug Retainer	1
	Thumb Screw	1
7	Wire Reel	1
8	Grommet	1

WIRE REEL STAND

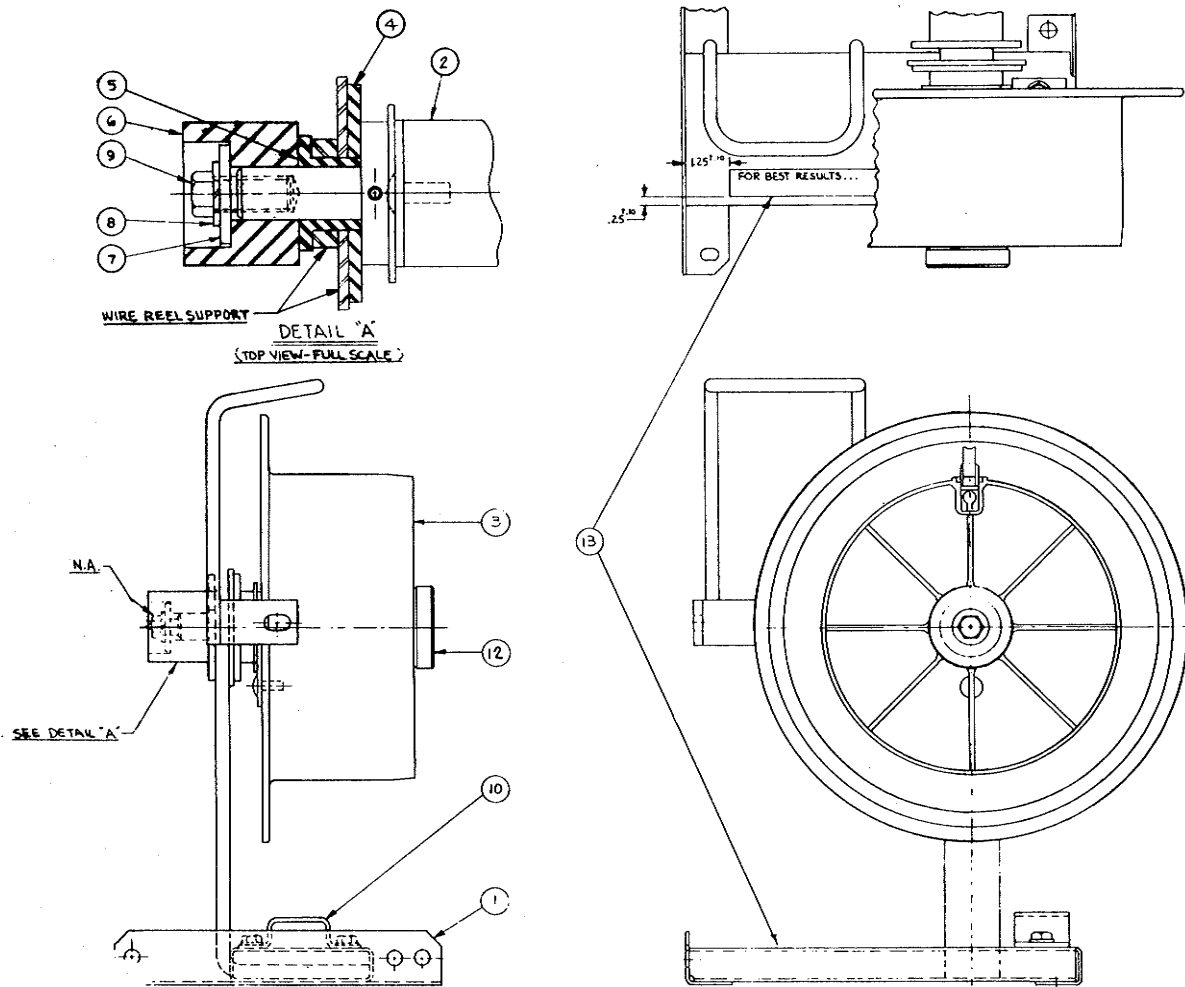

L-6832-P
12-19-85G

Parts List P-125-N

ITEM	PART NAME & DESCRIPTION	NO. REQ'D
1	Wire Reel Support Assembly	1
2	Wire Reel Shaft Assembly	1
2	Spindle Assembly	1
3	Readi-Reel Adapter	2
4	Insulating Washer	1
5	Insulator Bushing	1
6	Brake Disc Spacer	1
7	Plain Washer	1
8	Lock Washer	1
9	Hex Head Screw	1
10	Cable Clamp	1
12	Thread Cutting Screw	2
12	Retaining Collar (Not Illustrated)	1
13	Readi-Reel Decal	1
14	Plain Washer	1
	Optional — Not Illustrated	1
	10# Wire Reel Spacer	1

WIRE REEL SHAFT

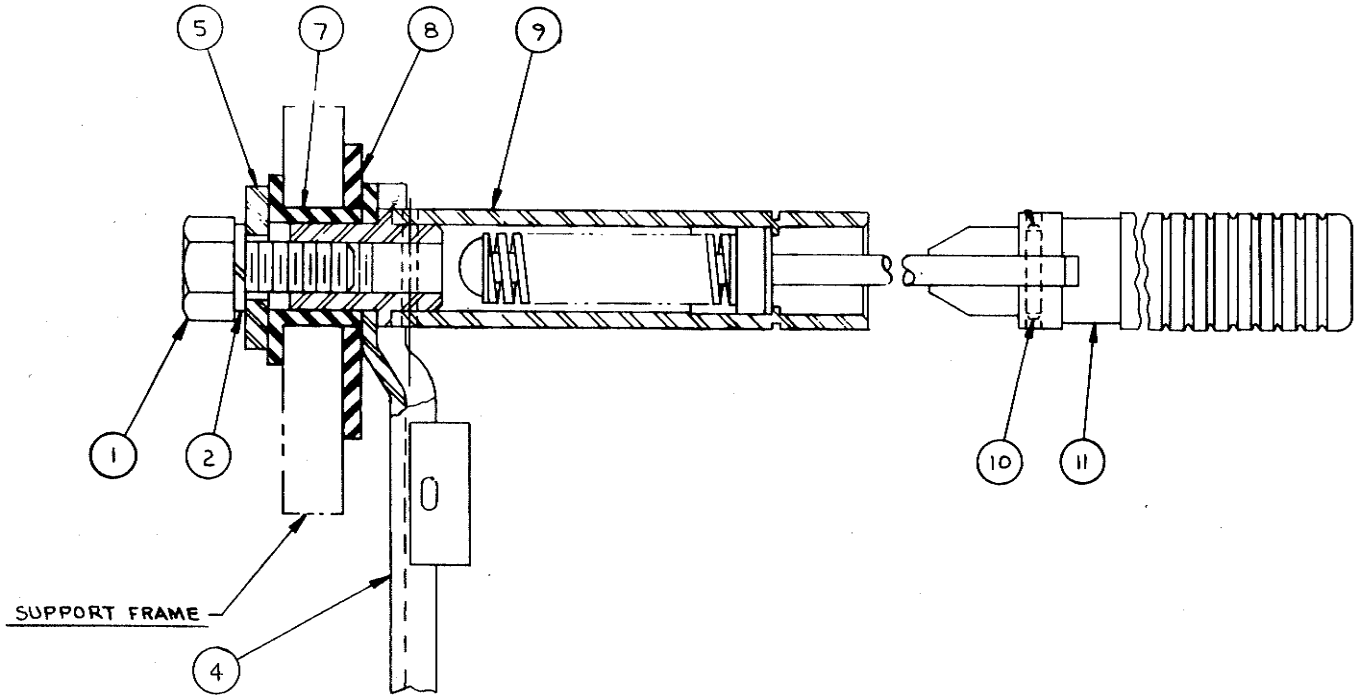

M-12460
10-28-83L

Parts List P-107-P

ITEM	PART NAME & DESCRIPTION	NO. REQ'D
1	Reel Mounting Shaft Assembly, Includes: Hex Head Bolt	1 1
2	Lock Washer	1
4	Brake Assembly, Includes: Brake	1 1
5	Cotter Pin	1
7	Plain Washer	1
8	Insulating Washer	1
9	Wire Reel Shaft Assembly	1
10	Roll Pin	1
11	Pull Knob	1

SP-200 WIRING DIAGRAM

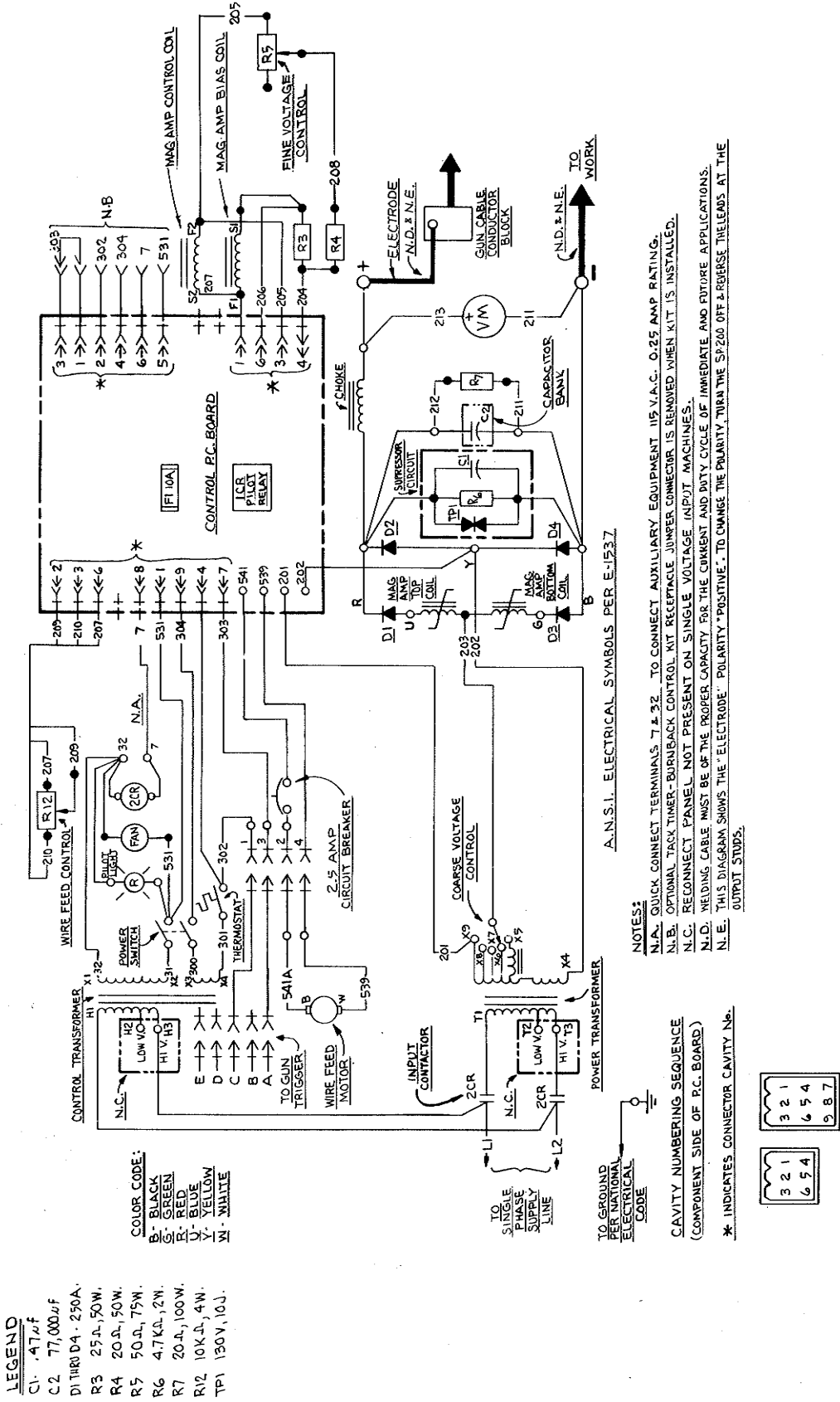

LEGEND

- C1 .47μf
- C2 77,000μf
- D1 THRU D4 250A.
- R3 25Ω, 50W.
- R4 20Ω, 50W.
- R5 50Ω, 75W.
- R6 4.7KΩ, 2W.
- R7 20Ω, 100W.
- R12 10KΩ, 4W.
- TP1 130V, 10J.

- COLOR CODE:**
 B - BLACK
 G - GREEN
 R - RED
 U - BLUE
 Y - YELLOW
 W - WHITE

A.N.S.I. ELECTRICAL SYMBOLS PER E-15.37

NOTES:

- N.A. QUICK CONNECT TERMINALS 7 & 32 TO CONNECT AUXILIARY EQUIPMENT UP V.A.C. 0.25 AMP RATING.
- N.B. OPTIONAL TRACK TIMER-BURNBACK CONTROL KIT RECEPTACLE JUMPER CONNECTOR IS REMOVED WHEN KIT IS INSTALLED.
- N.C. RECONNECT PANEL NOT PRESENT ON SINGLE VOLTAGE INPUT MACHINES.
- N.D. WELDING CABLE MUST BE OF THE PROPER CAPACITY FOR THE CURRENT AND DUTY CYCLE OF IMMEDIATE AND FUTURE APPLICATIONS.
- N.E. THIS DIAGRAM SHOWS THE "ELECTRODE" POLARITY "POSITIVE". TO CHANGE THE POLARITY, TURN THE SP200 OFF & REVERSE THE LEADS AT THE OUTPUT STUDS.

CAVITY NUMBERING SEQUENCE (COMPONENT SIDE OF P.C. BOARD)



* INDICATES CONNECTOR CAVITY No.

NOTE: This diagram is for reference only. It is not accurate for all machines covered by this manual. The specific diagram for a particular code is pasted inside the machine on one of the enclosure panels. If the diagram is illegible, write to the Service Department for a replacement. Give the welder code number.

M-14049
7-2-81D

SP-200 TIMER KIT

INSTALLATION INSTRUCTIONS FOR K-341 STITCH TIMER/SPOT WELD TIMER/BURNBACK KIT

1. Turn the "Power Switch" to "OFF".
Open side door to wire feed section. Observe jumper plug attached to six cavity connector in upper front corner of wire feed section.
2. Detach jumper plug from six cavity connector. Store plug on inside of timer kit case bottom.
3. Remove hex nut and lockwasher from the #10-24 screw going through the nameplate on the door side of the front panel. Remove hole plug from nameplate at "Spot-Seam-Stitch" switch hole.
4. Remove the sheet metal screw from inner case panel.
5. Connect six cavity connector to six cavity receptacle on P.C. Board of Timer Kit. When making this connection, be sure the connector is well seated in the receptacle.
6. Place the Timer Kit panel against back of front panel as shown below and re-insert 10-24 screw. Put lockwasher on and start-nut (do not tighten yet). Make sure that no leads are pinched between the sheet metal parts, and that the small toggle switch is thru the hole in the front of the machine.
7. Insert the sheet metal screw through slot in kit panel and into inner case panel.
8. Tighten down all screws.

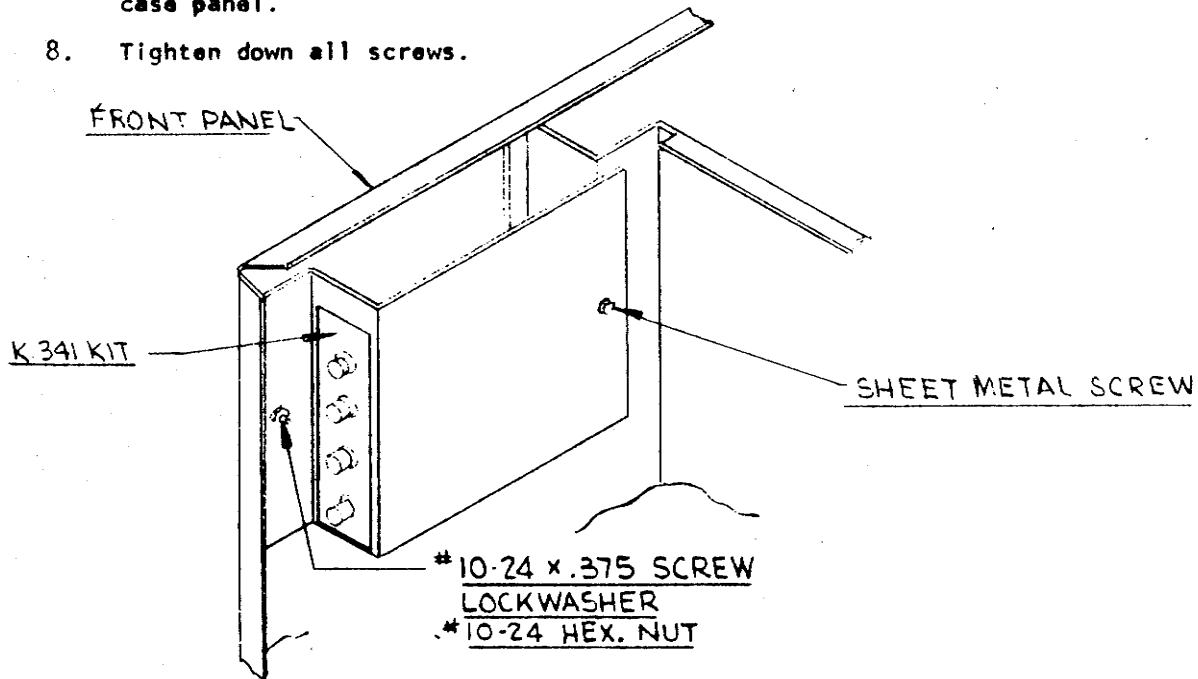

9. SEE SP-200 OPERATING MANUAL FOR OPERATING INSTRUCTIONS.

S-16982
5-14-82V

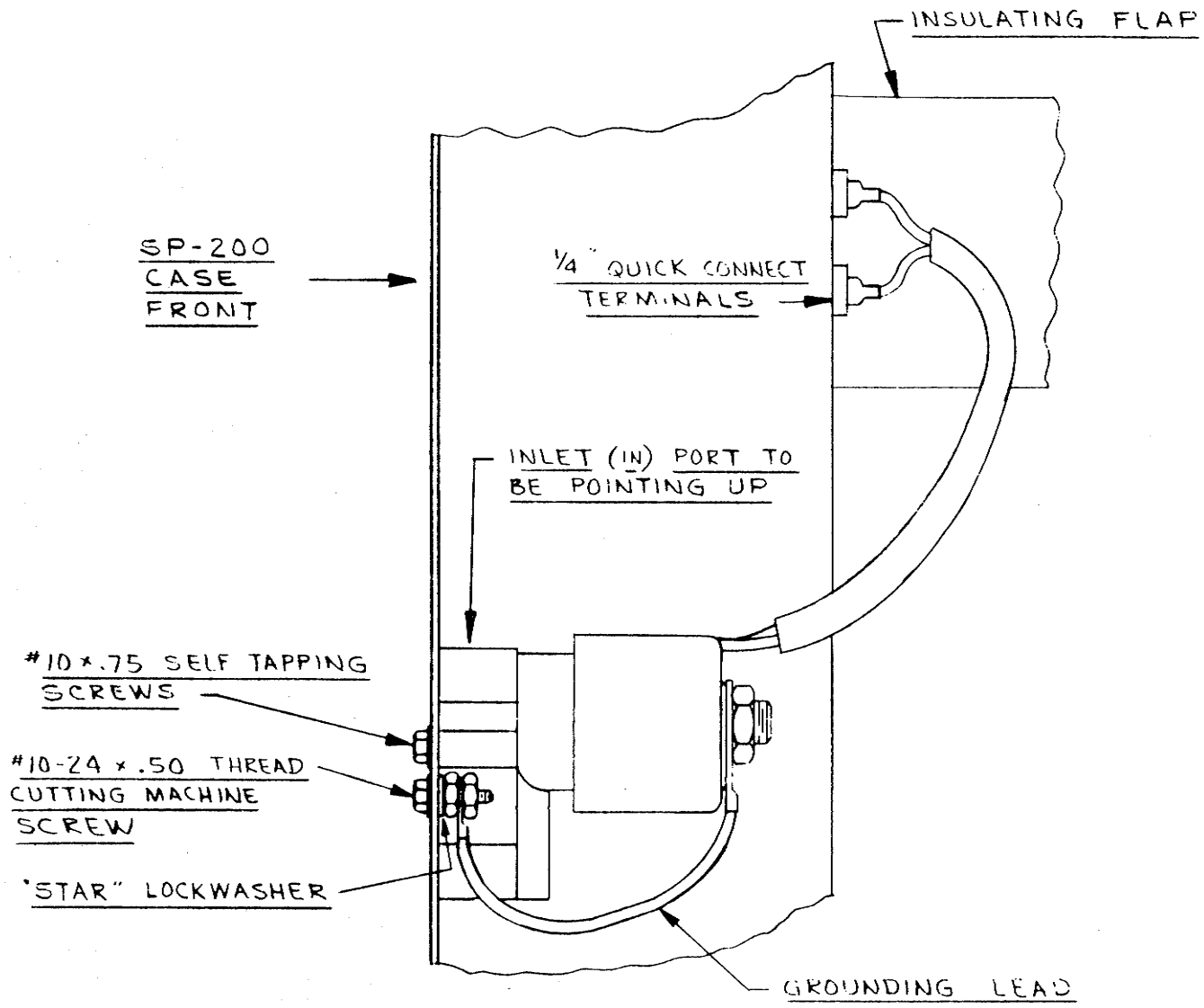

SOLENOID VALVE AND LEAD INSTALLATION

M-14889
8-27-84C

SP-200 TIMER KIT WIRING DIAGRAM

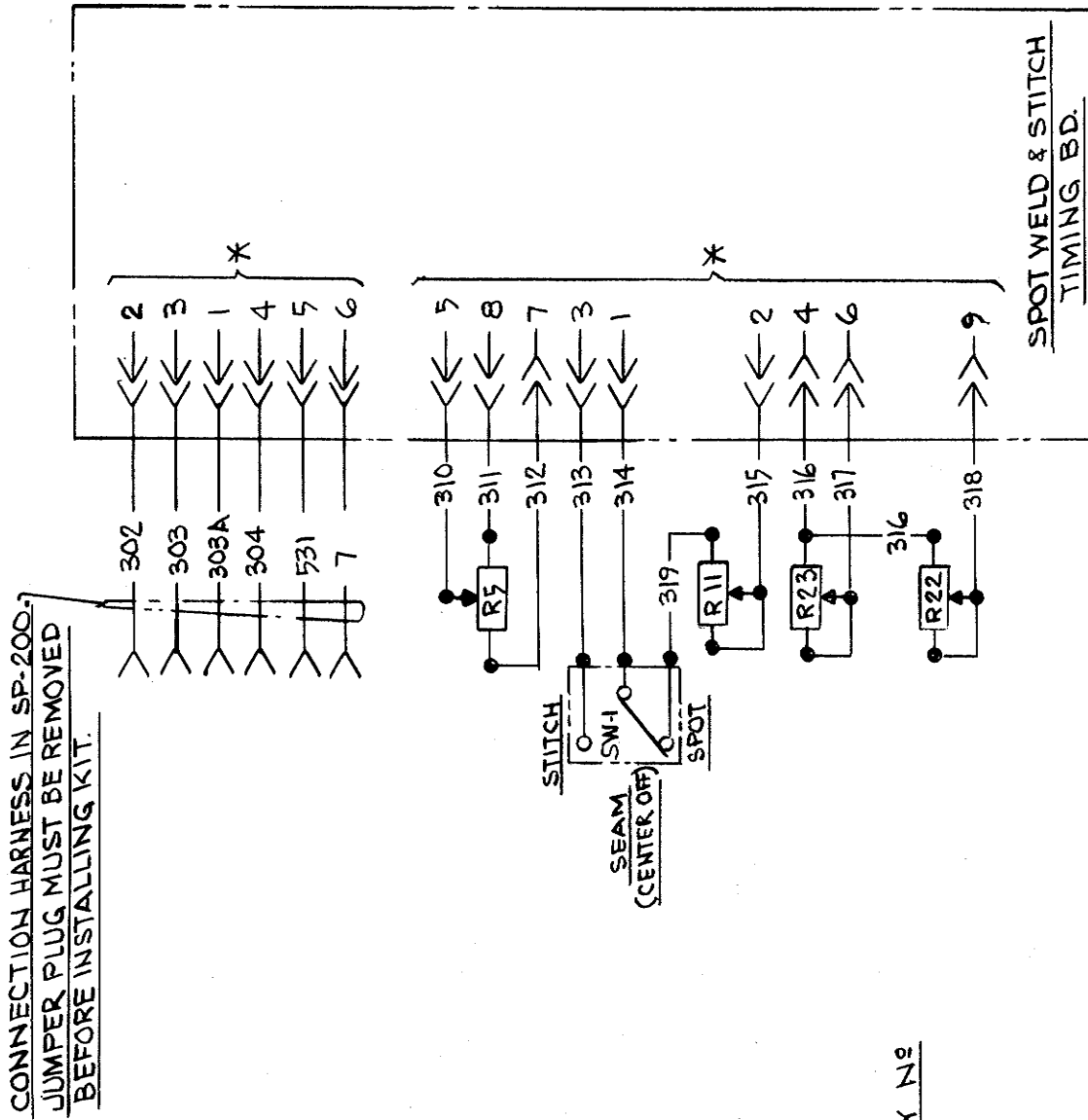

LEGEND

- R5 - 100K - 2W
- R11 - 100K - 2W
- R22 - 100K - 2W.
- R23 - 100K - 2W
- SW1 - MODE SWITCH

* INDICATE CONNECTOR CAVITY NO

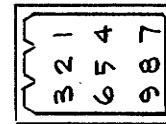
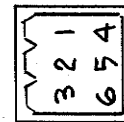

S-17049
1-30-81

This chart is a ready reference for using the Idealarc® SP-200. Refer to Lincoln bulletins and instruction manuals for details. Be sure to read and understand the section on ARC WELDING SAFETY PRECAUTIONS.

Because design, fabrication, assembly and welding variables affect the results obtained in applying this type of information, the serviceability of a product or assembly is the responsibility of the builder/user.

INNERSHIELD WELDING

Suggested settings. Adjustments may have to be made to achieve optimum results under various conditions. See "Welding Procedures" and "Problem Solving" sections of N675 and N677.

Electrode Size, Type, & Stickout	Application	Material Thickness	Wire Speed in/min	Volts Elec. Neg. DC(-)	Approx. Current Amps	Coarse Voltage Setting	Fine Voltage Setting
.068 NR-211 5/8" to 3/4" Electrical Stickout	single or multiple pass, mild steel	12 ga and thicker	75	18	190	14 — 19	4.5
.068 NR-152 1/2" Electrical Stickout	single pass, uncoated or galvanized mild steel up to 3/16" max. thickness	16 ga	50	15	165	14 — 19	2
		14 ga	60	16	195	14 — 19	3
		12 ga and 10 ga	70	17	220	14 — 19	3.5

INNERSHIELD WELDING

This process utilizes an easy-to-use self-shielded flux cored electrode. It is important to understand some of the special characteristics of Innershield electrodes and your SP-200. Refer to Lincoln booklets N675 and N677 and the Operating Manual (IM-312) for details.

Only .068" diameter Innershield electrodes can be used with the SP-200. Be sure the drives rolls and guide tubes are marked .068". Connect the wire feeder output leads for electrode negative. Be sure to properly load the wire reel. Use the **K-126 gun** and thread protector. The insulated guide supplied with the K-126 gun should not be used with .068 electrode. Choose the proper electrode and start by using the settings shown above. Maintaining the proper electrical stickout (the distance from the end of the contact tip to the weld puddle) is very important.

ELECTRICAL STICKOUT — Good weld quality requires using the electrical stickout specified. Electrical stickout is the distance from the end of the actual contact tip to the end of the electrode.

STARTING THE ARC — With the proper electrical stickout set, position the gun with the wire *lightly* touching the work. Press the gun trigger to start the weld.

Some weldors accustomed to stick electrode welding tend to push the gun into the joint as the wire burns away. Since the wire is mechanically fed, this is not necessary. Remember, it is very important to maintain the proper electrical stickout at all times. To stop the arc, release the trigger and pull the gun from the work.

SETTING VOLTAGE — Adjust voltage with the controls on the power source. Read the voltage on the power source voltmeter while the arc is lit.

SETTING WIRE SPEED (CURRENT) — Adjust the wire speed using the control on the wire feeder. Recommended wire speeds are given in the procedures.

TRAVEL SPEED — Move the gun along the joint at a travel speed which keeps the arc just at the front edge of the weld puddle and produces the desired weld size. Always maintain a uniform travel speed.

DRAG ANGLE — Tilt the gun in the direction of travel about the same as required in stick electrode welding. If slag tends to run ahead of the arc, increase the drag angle slightly.

ELECTRODE ANGLE TO JOINT — Point the electrode into the joint. The wire angle to the joint should be about 45° for fillet welds.

MIG WELDING

THE SP-200 IS AN EXCELLENT MACHINE FOR MIG WELDING WITH MILD STEEL, STAINLESS STEEL, ALUMINUM, OR BRONZE (FOR GALVANIZED STEEL) FILLER WIRE, AS WELL AS FOR AUTO STITCH AND AUTO SPOT WELDING. THE MACHINE SETTING GUIDELINES SUPPLIED ABOVE SHOULD BE SUPPLEMENTED WITH APPROPRIATE MIG WELDING INFORMATION TO ENSURE THE CORRECT USE OF EQUIPMENT AND PROCEDURES. THE LINCOLN ELECTRIC COMPANY DOES NOT SUPPLY PROCEDURES FOR ANY OF THE MIG PROCESSES.

"AUTO STITCH" AND "AUTO SPOT" WELDING

Suggested settings. Adjustments may have to be made to achieve optimum results under various conditions. Also read section below on "MIG Welding".

Wire Size & Type	Material Thickness	Wire Speed in/min	Volts Elec. Pos. DC(+)	Coarse Voltage Setting	Fine Voltage Setting	Stitch On Time	Stitch Off Time	Spot Time for Plug Spot Welds
.030 L-50	18 Ga (.048)	150	17	14 — 19	2.5	2.5	2	4
	20 Ga (.036)	125	16	Min — 16	7	2.5	2	5
	22 Ga (.030)	110	16	Min — 16	5.0	2.5	2	5
.035 L-50	24 Ga (.024)	100	16	Min — 16	4.5	2.5	2	5
	18 Ga (.048)	125	17	14 — 19	2.5	2.5	2	4
	20 Ga (.036)	110	16	14 — 19	1.5	2.5	2	5
	22 Ga (.030)	100	16	Min — 16	7	2.5	2	5

BURNBACK CONTROL

This control sets the time the arc is on after wire feed stops. Increase time only if welding wire sticks to the end of the weld.

STITCH TIMER ("AUTO STITCH")

Used to weld thin material where warpage and burnthrough are a problem. Proper adjustment of ON and OFF times and arc travel speed permits welding 18 through 24 gage (.048" — .024") sheet metal with small welds, minimum distortion, and no burnthrough.

To weld, set "WELD MODE SELECTOR" to "STITCH" and the other controls per the above table. Close trigger and hold it closed for length of seam. Hold gun in one place during ON time and move gun just beyond edge of molten metal during OFF time.

"STITCH ON TIME" control — sets welding time. Raise setting to increase penetration and weld size; lower to reduce burnthrough and distortion.

"STITCH OFF TIME" control — sets off time. Raise setting to reduce burnthrough; lower to make weld flatter and smoother.

NOTE: For smoothest welds on thinner metal, point gun slightly towards direction of travel.

SPOTWELD TIMER ("AUTO SPOT")

Arc spot plug welds are used when continuous welds are not needed or to hold thin sheet metal together prior to Auto Stitch Welding or continuous welding. Plug welds are made by punching a 3/16 inch hole in the top sheet and arc welding through the hole into the back sheet.

To make an arc spot plug weld, punch 3/16 holes in top sheet. Set "WELD MODE SELECTOR" to "SPOT" and the other controls per the above table. Install spot weld nozzle (if available) on gun and press it against the top sheet so the top and bottom sheets are tight together. Close trigger and hold it closed till the arc goes out. If a spot weld nozzle is not used, smoother welds will result by moving the welding wire in a small circle during the weld.

"SPOTWELD TIME" control — sets welding time. Higher settings increase penetration, diameter, and height of weld.

METAL SHRINKING

The SP-200 can be used with a carbon rod to produce localized heating and, when combined with water quenching, can remove small dents and distortion in sheet metal.

For Metal Shrinking set "WELD MODE SELECTOR" to "SEAM" and "COARSE" and "FINE" arc voltage controls to lowest setting. Press "WIRE FEED CIRCUIT BREAKER" to turn wire feed off. Connect output leads for electrode positive. Attach a carbon rod to the welding gun using a special attachment or use a separate electrode lead and stick electrode holder with a carbon rod. Place the pointed end of the carbon rod (do not use copper coated carbon rods) firmly against the sheet metal in the distorted area. Close the gun trigger and move the rod in a circular motion keeping in contact with work. When distortion is reduced, release trigger, remove carbon, and immediately quench area with a water-soaked rag. Repeat if required. To prevent arcing, carbon must be firmly against sheet metal whenever trigger is closed or opened.

METAL FILL

This procedure is used to fill gaps, holes and distorted areas in sheet metal.

NOTE: This procedure should not be used where weld strength is required.

To Metal Fill on steel sheet metal, set "WELD MODE SELECTOR" to "SEAM", plus "COARSE" and "FINE" voltage controls to lowest settings. Set "WIRE SPEED" to 300 in/min for .035 wire and 375 in/min for .030 wire. Connect wire feeder output leads for electrode positive. An arc welding shield with a #8 filter must be used to protect the eyes from heat and brightness. Start with the wire sticking out about 1" beyond the gun tip and the wire lightly touching the sheet metal. Close the trigger and slowly weave the gun back and forth over the area to be filled. If there is arcing and flashing, increase the "WIRE SPEED" and/or decrease the wire stickout. If the wire pushes the gun back, decrease the "WIRE SPEED" and/or increase the wire stickout. After filling, set the "WELD MODE SELECTOR" for "STITCH" or "SEAM" and arc weld the fill metal to the base metal.

PROCEDURE TO INSTALL DRIVE ROLL AND GUIDE TUBES

- Turn off power.
- Remove hex screw and clamping collar from drive shaft with 1/2" wrench. Loosen idle roll.
- Install key and drive roll. Double grooved drive roll for .023"-.035" to be installed with side stenciled for correct wire size facing out and with slotted spacer on top of roll. Two piece drive rolls for .068" have spacer between rolls. Replace collar and tighten hex screw.
- Back out two guide tube set screws.
- Install longer guide tube in rear hole.
- Install other guide tube through front hole. Fine wire chisel point tube must have largest radius next to drive roll.
- With tubes properly seated, tighten set screws.
- Tighten idle roll pressure screw and back out 2 turns for larger wires. For aluminum and .023"-.052" steel wire screw must be backed out to prevent buckling with wire stoppage (see Operating Manual).
- To start new electrode, straighten the first 6" and cut off first inch. Insert free end thru incoming guide tube. Press gun trigger and push wire into drive roll.

WARNING: When inching with gun trigger, electrode and drive mechanism are "hot" to work and ground.

HOW TO ORDER REPLACEMENT PARTS

Order parts only from Lincoln offices or from the Authorized Field Service Shops listed in the "Service Directory". Give the following information:

- (a) From the nameplate — machine model, code and serial numbers.
- (b) From this manual — complete part name and descrip-

tion, item number, quantity required and the number of the list used to get this information.

Any items indented in the "Parts Name" column are included in the assembly under which they are listed. The indented items may be ordered separately. If the entire assembly is needed, do **not** order the indented parts.

**WARRANTY SUPERSEDED
SEE IMWS 1**

Need Welding Training?

The Lincoln Electric Company operates the oldest and most respected Arc Welding School in the United States at its corporate headquarters in Cleveland, Ohio. Over 60,000 students have graduated. Tuition is low and the training is "hands on".

For details write: Lincoln Welding School
22801 St. Clair Ave.
Cleveland, Ohio 44117-1199

and ask for bulletin ED-80 or call 216-481-8100 and ask for the Welding School Registrar.

**LINCOLN
ELECTRIC**®

THE LINCOLN ELECTRIC COMPANY

World's Largest Manufacturer of Arc Welding Products • Manufacturer of Industrial Motors
Sales and Service Worldwide
Cleveland, Ohio 44117-1199 U.S.A.
Toronto M4G 2B9 - Canada • Sydney 2211 - Australia • Rouen 76120 - France

Litho in U.S.A.

Eff. April '88

Ram

5-84