

CUTTING MACHINE

# TORCHMATE™

# 1530HD

SAFETY INSTRUCTIONS FOR OPERATING AND MAINTENANCE

No AS-CM-TMT1530HD170 - AS-CM-TMT1530HD300

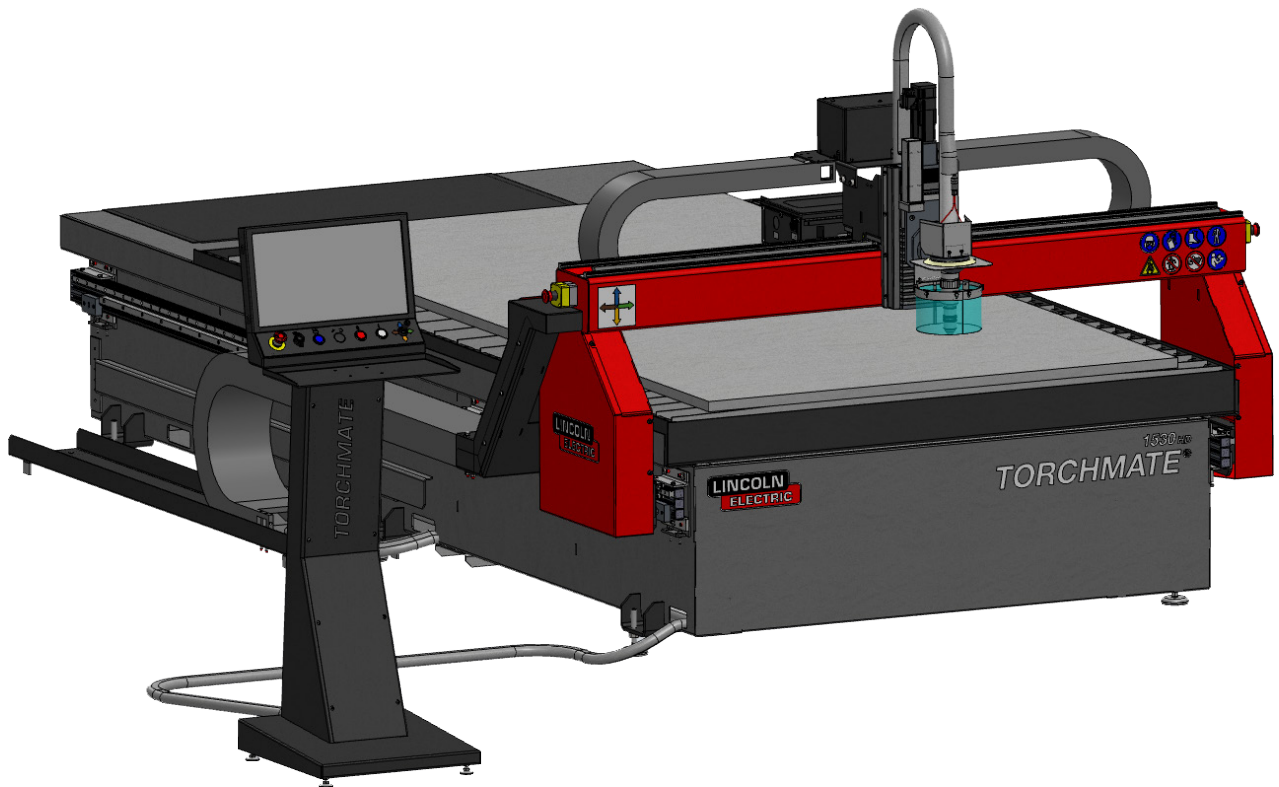

ISSUE : EN  
REVISION : A  
DATE : 01 - 2025

Instructions

REF: 8695 4793

Original instructions

**LINCOLN**®  
**ELECTRIC**

**Thank you very much for the trust you have shown by choosing this piece of equipment. It will give you trouble-free service if it is used and maintained as recommended.**

**Its design, component specifications and manufacturing are in accordance with applicable European directives.**

**Please refer to the CE declaration enclosed to identify the directives applicable to it.**

**The manufacturer shall not be liable for any combination of parts not recommended by it.**

**For your safety, please follow the non-limitative list of recommendations and obligations, a large part of which are included in the Labour Code.**

**Please inform your supplier if you find any error in this instruction manual.**

# Table of contents

<b>A - IDENTIFICATION</b> .....	1
<b>B - SAFETY INSTRUCTIONS</b> .....	2
1 - Limits of use of the machine or the installation -----	2
2 - Residual risks -----	4
3 - Location -----	8
<b>C - DESCRIPTION</b> .....	9
1 - Overview -----	9
2 - General -----	10
3 - Cutting table -----	11
4 - Beam -----	12
5 - Transverse carriage -----	12
6 - Power systems-----	12
7 - Console-----	13
<b>D - ASSEMBLY AND INSTALLATION</b> .....	14
1 - Installation conditions-----	14
2 - Floor preparation-----	14
3 - Slings-----	15
4 - Putting in place the TORCHMATE™ 1530 HD-----	15
5 - Connecting the energy supplies -----	17
5.1 Connection to the mains-----	17
5.2 Connection to the pneumatic system -----	17
5.3 Gas connections-----	17
<b>E - OPERATING MANUAL</b> .....	18
1 - Description of controls-----	18
2 - Starting up and shutting down -----	19
2.1 Starting up-----	19
2.2 Shutting down-----	21
<b>F - MAINTENANCE</b> .....	22
1 - Care -----	22
1.1 Maintenance schedule-----	23
2 - Troubleshooting-----	27
3 - HMI alarm -----	27
4 - Spare parts -----	30
4.1 Longitudinal and transverse power systems -----	31
4.2 Guidance and transmission -----	32
4.3 Cutting table -----	33
4.4 Electrical components-----	34
<b>PERSONAL NOTES</b> .....	36

# REVISIONS

REVISION : A                      DATE : 01/25

DESIGNATION	PAGE
Creation	

# INFORMATION

This technical literature is intended for the following machines or products:

- TORCHMATE™ 1530HD FINELINE 170 ⚡ AS-CM-TMT1530HD170
- TORCHMATE™ 1530HD FINELINE 300 ⚡ AS-CM-TMT1530HD300



This manual and the product with which it is associated refer to the applicable standards in force.



### **Use of the equipment:**

Please read this manual before you start handling, installing or using the machine. Keep the manual safe in a place known to the machine user and maintenance personnel until the machine is finally destroyed.

This manual explains how to transport, install, use and maintain the machine. It cannot in any event replace the experience of the user for operations of varying difficulty.

Before the machine is used by a new user, make sure that they have read this manual and understood all the explanations provided.

For any further information, please feel free to contact the technical staff of **Lincoln Electric**.



This document must follow the machine described if there is a change in ownership of the machine and accompany it up to demolition.



### **Display and pressure gauge:**

Measurement instruments or displays of voltage, intensity, speed, accuracy etc. are to be considered as indicators, whether they are analogue or digital.



For operating instructions, adjustments, troubleshooting and spare parts, please refer to the specific safety, operating and maintenance instructions.



### **PLEASE CHECK THE BOX AND EQUIPMENT IMMEDIATELY FOR DAMAGE**

When the equipment is shipped, ownership is transferred to the buyer as soon as it is received by the carrier. As a result, any complaints relating to damage during shipment must be made to the carrier's company when the equipment is received.































### **Assistance:**

**Lincoln Electric** is at your disposal for any work on your equipment. Please send any requests to the technical department.

**HOT LINE (+33) 825 132 132**

## MEANING OF SYMBOLS

	Reading the manual/instructions is mandatory.		Indicates a hazard.
	Mandatory use of safety shoes.		Warning of an electricity risk or hazard.
	Mandatory use of hearing protection.		Warning of a risk or hazard due to an obstacle on the floor.
	Mandatory use of a safety helmet.		Warning of a risk or hazard of falling with a level change.
	Mandatory use of safety gloves.		Warning of a risk or hazard due to suspended loads.
	Mandatory use of safety glasses.		Warning of a risk or hazard due to a hot surface.
	Mandatory use of a safety visor.		Warning of a risk or hazard due to moving mechanical parts.
	Mandatory use of safety clothing.		Warning of a risk or hazard due to a closing movement of mechanical parts of a machine.
	Make sure you clean the working zone.		Warning of a risk or hazard due to laser radiation.
	Mandatory use of breathing protection.		Warning of a risk or hazard due to an obstacle at a height.
	Visual inspection required.		Warning of a risk or hazard due to the presence of a pointed part.
	Indicates a lubrication operation.		Warns of an explosion hazard
	Requires maintenance action.		Warns of a fire hazard
	Wearers of pacemakers may not be admitted in the designated area.		No climbing/stepping.



## B - SAFETY INSTRUCTIONS



For general safety instructions, please refer to the specific manual supplied with the equipment.



### **AIRBORNE NOISE:**

Refer to the special instructions 8695 7050 supplied with the equipment.



In spite of all the measures applied, invisible residual risks may still remain. Residual risks can be reduced if the safety instructions are observed, the machine is used as recommended and general service instructions are followed.

## 1 - Limits of use of the machine or the installation



The limits of use of the machine (or installation) are provided in the different documents; please review them carefully before starting to use the machine (or installation).

The machine (or installation) is designed for professional use.

The machine (or installation) may only be used cutting applications; any other use of the machine is forbidden.

The machine (or installation) is designed for indoor use.  
It may not be used outdoors.

For safety reasons, and in the light of our current knowledge of customer processes, the working area may be occupied only by one individual.

The machine (or installation) may only be operated by a single person above the age of 18 and trained in operating and use-related risks.

The table has an extraction system to extract fumes and carry away the heat resulting from cutting. The machine is designed for outdoor discharge.

If the fumes are discharged indoors (not recommended), the workshop in which fumes are discharged must be ventilated so as to not reach the professional exposure limit value of pollutants (fumes and gases).

The workshop must be adequately lit and ventilated.

Mechanical or electrostatic filtration systems are effective for the filtration of solid particles, but not gaseous particles.

Before use, the operator must make sure that there is no risk of collision with personnel.

The energy supply must imperatively comply with recommendations.

The table is designed for dry cutting.

The machine may not be used in an explosive atmosphere (not Atex certified).

The table measures 1500\*3000, and the operator need not climb on the table. Climbing on the table is thus forbidden.

The maximum exterior temperature is 40°.

The maximum usage time of the machine is twice 8 hours every day.



The maximum thickness of the plate to cut is 50mm.

The maximum dimensions of the plate to cut are 1500 mm x 3000 mm.

Before using the machine. Make sure that the guard covers of the electrical and mechanical parts are in place before starting up the equipment.  
All guard covers must be screwed in.

No climbing on the structure of the machine.

To access equipment at heights, the user must use accessing means in accordance with the regulations, such as a safe mobile gangway, an aerial lift etc.”.

Never modify the machine.

The machine is not designed for anchoring handling equipment.

The use of Personal Protective Equipment (PPE) and work clothing covering the body is mandatory in the work area. Do not wear a tie and keep your hair tied back securely.



For any extended absence, the operator must shut off the supply of utilities (electricity and fluids).

Maintenance may only be carried out by experienced personnel who are trained in machine-related risks.

Access to the machine (or installation) must be left free for maintenance (e.g. no workpiece etc.).

The frequency of such maintenance is indicated for production in one work shift per day (i.e. 8 hours a day).

Machine maintenance must be carried out with all the energy supplies switched off.  
The disconnection and padlocking of all energy sources is mandatory.

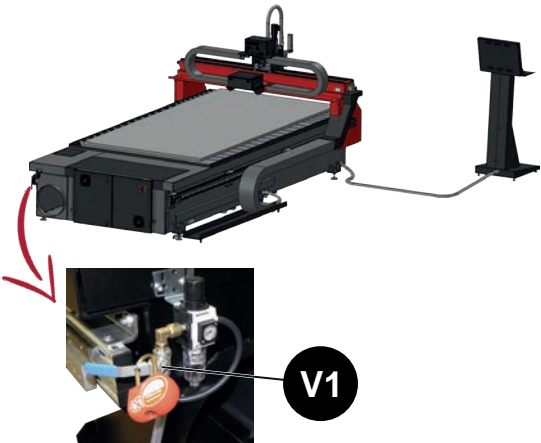
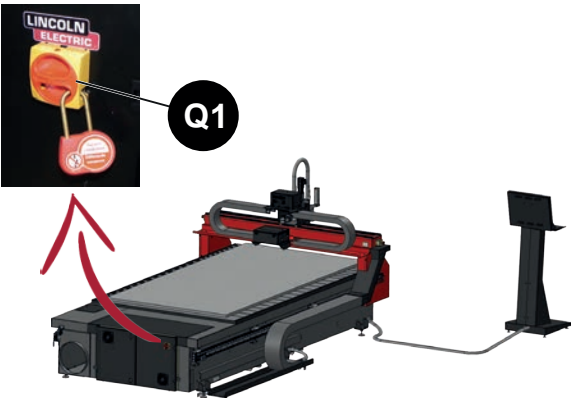
Pneumatic locking out	Electrical locking out
Pneumatic locking out is achieved by means of the disconnecting valve « V1 ».	Electrical locking out is achieved by means of the disconnecter « Q1 ».
	

Consumables must be changed based on their wear and tear.

Visually inspect the overall condition of the installation and the working area twice a shift, or with every change of production.

Clean the working area from time to time.

The maintenance schedule must absolutely be followed.

We recommend putting in place a traced system for tracking all your maintenance operations.

All maintenance must be carried out by specialised personnel who have read and understood these instructions.

#### Electricity technician

Qualified operator with the ability to work in normal conditions on electrical parts for regulation, maintenance and repair.

#### Mechanical technician

Specialised technician authorised to carry out complex and exceptional mechanical operations.

Any change in the machine location must be made by Lincoln Electric or authorised personnel.

## 2 - Residual risks

---

Based on the results of the risk assessment, a few elements have emerged where there was no “technical” solution for eliminating risk or making it negligible.

In spite of all the care that has gone into the designing of our machines (or installations), some risk areas remain. To control these risks, the customer must pay particular attention to them, ensure that the instructions are applied and define any additional measures that may be necessary in view of its own internal operating procedures.

Therefore, you will find below a guidance list of residual risks.

Training of operators in safety and in the use of the machine from their operating position will better address these residual risks.

We recommend putting place workstation instructions that remind users of the presence or otherwise of residual risks in the working area.

### 2.1 - Residual risks - General

#### ☛ Environment risk - slipping and/or falling



The working and safety area must be clear of all obstacles.

The working area must be kept clean and cleaned regularly (dust, dross, coolant etc.).

The machine must undergo periodic maintenance, with the power switched off (see maintenance instructions of each piece of equipment). In particular, cutting or grinding dust around the machine must be cleaned.

Waste consumables must be cleaned.

The operator must pay special attention to cables and rolling tracks on the ground.

The operator must use the necessary personal protective equipment (helmet, gloves, safety shoes, mask and work clothing).

While unpacking the machine, the area around the **TORCHMATE™ HD** must be sufficiently large and clear, in order to avoid falls. A cluttered area increases the risk of tripping and slipping

While installing the machine, follow the recommendations for installation provided in the layout drawing, particularly the absence of workers and obstacles in the area around the machine marked on the floor.

The lighting on the control panel must be at least 500 lux (measured at the control panel), to avoid fatigue and falls.

The machine is only designed for dry cutting, in a sheltered area. The table is not designed for receiving large quantities of water or lubricant: risk of leaks, slipping and falling

To avoid tripping on cables, all cables must be placed in cable channels or gutters provided for that purpose. Passage areas must be demarcated.

At the end of the installation process, dispose of any packaging waste appropriately based on its type.

#### Falling from heights:

In order to be protected from falling from heights and for access to high parts, the operator or technician must use access means that comply with applicable standards (e.g. during the assembly, disassembly or maintenance of ducts).

For all work at heights, the use of personal protective equipment (helmet, gloves, safety shoes, mask, ear muffs and harness) is indispensable.

For all work at heights, the operator must be trained in the use of means for accessing high locations.

Do not climb on cutting tables when the machine is operating and/or when parts are being handled. The cutting table dimensions allow the collection of parts without climbing on the machine.

#### ☛ **Mechanical risk - Impacts, shearing, crushing**



The operator may not wear loose clothing or a tie, must have their hair tied back and use personal protective equipment (helmet, gloves, safety shoes, mask and work clothing).

The operator must make sure that nobody else is close to the machine before starting.

The **TORCHMATE™ HD** may not operate without all its safety components and guards. The operator must make sure that all the machine guards are in place before using it.

**IMPORTANT:** "Do not remove the Nylstop nuts from the fastening screws of the guards: they keep them captive"

The machine must necessarily be switched off using its disconnecter before any work on any part of the **TORCHMATE™ HD** (electrical or other).

The operator's working position is before the control console.

The machine safety areas must not be crossed. The machine and the area marked on the floor around the machine (500mm minimum around the machine) must be free from obstacles or workers.

The operator must be trained in the use of the machine, and all personnel must be aware of residual risks.

The operator must be trained in the use of the machine, and all personnel must be aware of residual risks.

The operator must use personal protective equipment, (helmet, gloves, safety shoes, mask and work clothing).

The operator's working position is before the control console.

The operator must make sure nobody is present in the machine working area or safety area before using it.

While handling the machine, the operation must be carried out by an individual trained in the use of mechanical handling equipment.

#### Anchoring failure of handling equipment

The machine may not be modified.

The machine is not designed for anchoring lifting equipment.

#### ☛ **Mechanical risk - Puncturing or piercing**



The use of personal protective equipment (helmet, gloves, safety shoes, mask, ear muffs) is indispensable, particularly while installing fume ducts (sharp parts).

The operator must be trained in the use of the machine and all personnel must be aware of residual risks.

While opening machine packages, use appropriate tools to avoid cuts and wear appropriate personal protective equipment (work clothing, gloves).

The machine has expendable plates that are sharp and abrasive. To limit risks, the use of personal protective equipment is mandatory, as it can mitigate potential impacts (work clothing, safety gloves and shoes, possibly a helmet)

#### ☛ **Noise risk - Fatigue**



#### Process noise

The use of personal protective equipment (helmet, gloves, safety shoes, mask, ear muffs) is indispensable.

The operator must be trained in the use of the machine and all personnel must be aware of residual risks.

## ☛ Explosion hazard



Any explosive gases that may be emitted by the process are collected by the extraction system. That is why the working of the filter and extraction hatches must be verified from time to time. The machine must necessarily be located in a non-Atex area. The cutting table is designed for cutting ferrous materials only. The table may not be used for grinding or sanding (risk of emission of potentially explosive dust).

## ☛ Fire hazard



The working area must be cleaned regularly  
Remove any flammable substances or unnecessary combustible material in and around the cutting area  
Do not dispose of waste in the containers: fire hazard.  
In case of fire, press the emergency stop to stop the machine and the extraction system

## 2.2 - Residual risks during operation or simple maintenance

### ☛ Electrical risk - Electric shock or electrocution



#### Contact with electrical parts

Access to the electrical cabinet must be restricted to authorised personnel.  
The machine must necessarily be switched off using its disconnecter before any work on any part of the **TORCHMATE™ HD** (electrical or other).  
All the utility supplies (electricity, air, gas) must necessarily be disconnected, padlocked and purged. Contact with electrical parts, including after the machine has been switched off, could lead to serious injury. After the machine has been switched off, wait for 5 minutes before starting to work on the variable drive (residual voltage above several hundred volts may be present for several minutes).  
From time to time, check that the machinery and its electrical accessories - connectors, flexible cables and extension cords - are correctly insulated and connected.  
Work for maintaining and repairing insulating ducts and enclosures may not be carried out in a haphazard manner.

- All repairs are to be carried out by specialists, or better yet, defective accessories should be replaced.
- Regularly check that the electrical connections are tight, with no heating

The use of personal protective equipment (helmet, gloves, safety shoes, mask, ear muffs, fire-resistant work clothing) is indispensable.

The operator must be trained in the use of the machine, and all personnel must be aware of residual risks.

#### Access to active parts in the electrical cabinet

Only authorised personnel may access electrical cabinets. The cabinet is protected by a lock.

#### Access to unprotected active parts

Only authorised personnel may access electrical components. Machine maintenance must be carried out with all the energy supplies switched off.

#### Access to parts that could be live accidentally

Cables must be placed in protected cable channels on the floor (themselves connected to the earth) or protected in a technical gutter.

Cables and connectors must be inspected from time to time and replaced with identical parts if they are damaged.

#### Electrical cabinet connected to an outside element

There could be an outside power supply in the electrical cabinet that is not switched off with the main disconnecter.

In that case, the outside power supply must be identifiable by orange wires and terminals.

## ☛ Ergonomics risk - Fatigue



### Process noise

The noise level is indicated in the manual relating to the process used. The use of hearing protection is mandatory for the processes used by this machine

### Machine noise

The use of hearing protection, which is mandatory for the processes used by this machine, covers the risk of noise emitted by the machine

### Changing/emptying containers

The operator must use appropriate handling means.

The operator must be trained in the use of the machine, and all personnel must be aware of residual risks.

## ☛ Material and product risks - Poisoning



### Emission of fumes/dust

The use of personal protective equipment (helmet, gloves, safety shoes, mask, ear muffs, work clothing) is indispensable.

The operator must be trained in the use of the machine, and all personnel must be aware of residual risks.

## ☛ Mechanical risk - Puncturing or piercing



### Contact with a part of the pneumatic circuit that is under pressure

Before any work on the pneumatic circuit, the pneumatic supply must be switched off and the circuit must be purged to avoid any accidental lashing of the hoses.

The use of personal protective equipment (helmet, gloves, safety shoes, mask, ear muffs) is indispensable.

The operator must be trained in the use of the machine and all personnel must be aware of residual risks.

## ☛ Thermal risk - Burns



### Part of the body in contact with a hot part (torch- workpiece etc.)

The use of personal protective equipment (helmet, gloves, safety shoes, mask, ear muffs) is indispensable.

The operator must be trained in the use of the machine and all personnel must be aware of residual risks.

Cut parts and the torch may remain hot for a certain length of time after cutting.

The user must protect the area around the machine (emission of dross).

Strikes should be turned towards a non-hazardous area.

The use of the extraction system is mandatory during cutting, as it will remove dross, fumes and hot gases and thus remove heat

## ☛ Electrical - fire hazard



The machine is protected by fuses.

Replace used fuses with fuses of the same type and rating. Risk of damage to property and fire

☛ **Illness - pollution hazard**



Check the working of the hatches from time to time, generally as soon as fume emissions appear to be too great. (see maintenance section). Risk of emission of carcinogenic fumes.

Residue and dust (recovered while cleaning containers) must be treated in accordance with local laws and regulations.

For cleaning the containers, see the particular safety instructions in the Maintenance section.

The filtration equipment, which is exclusively used for extracted air, must be fitted with appropriate filters, offer the recommended flow rate and undergo inspection from time to time.

The table and filter are rated for a sufficient flow rate with half the table covered.

### 3 - Location



The operator station is located before the control console.

The machine you have purchased can be hazardous if you do not take certain precautions for use. Make sure that no part of the machine can come within less than 500 mm from an obstacle. Important: the operator passage way must absolutely be clear over a minimum width of 800 mm according to safety standards. The floor should be marked out as shown in the enclosed drawing. While accessing the marked area, a worker could be hit by the machine or the cable drag chain.



Refer to the following:

- supplied layout drawing

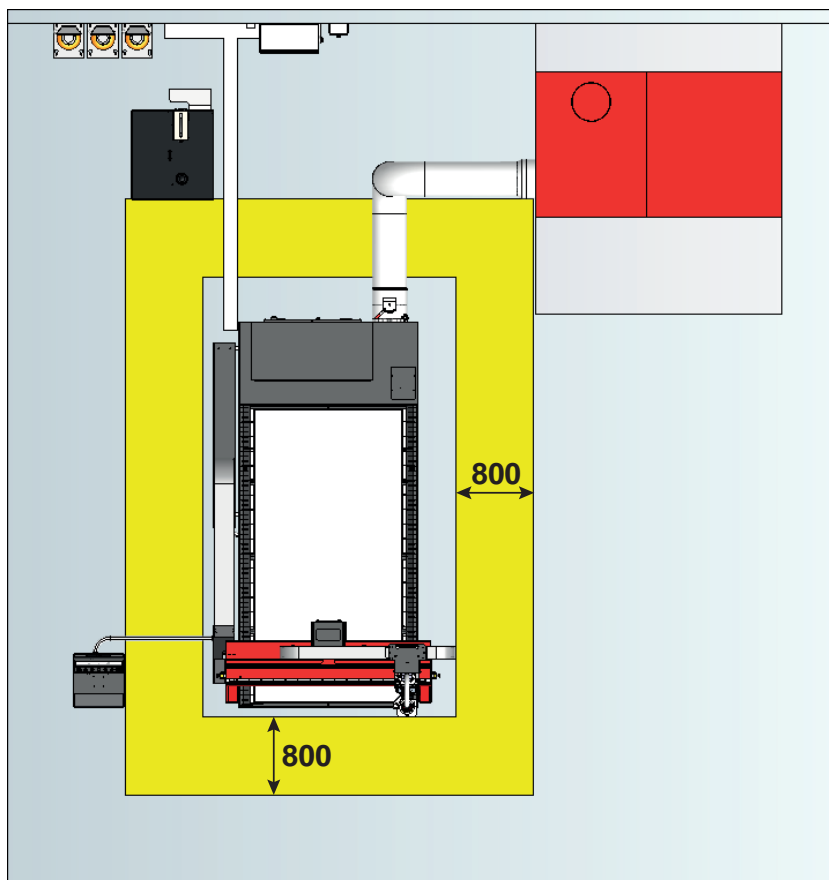

Example of layout of a **TORCHMATE™ HD** installation with extraction system.



For your safety and optimum performance, please read this installation manual carefully before using the machine.

1 - Overview

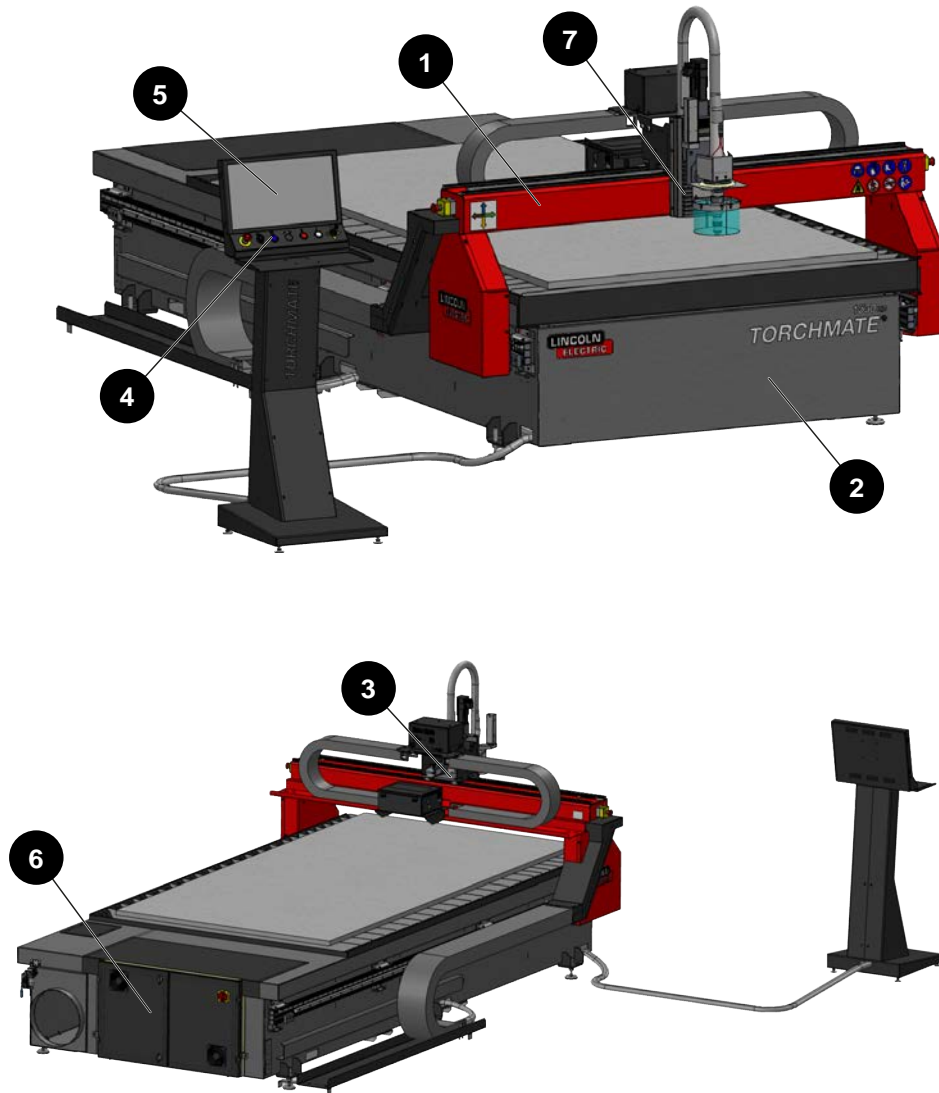

1	Beam
2	Cutting table with guide rails
3	Tool carriage
4	Control panel
5	<b>HPC DIGITAL PROCESS III</b> CNC control
6	Electrical power system
7	Tool holder

## 2 - General

This is a numerically controlled single-piece plasma cutting machine that is particularly suited to industries that use steel, stainless steel and aluminium for plates measuring 1500\*3000.

The main intended applications are those of iron workers, metal workers, air processing, air-conditioning, ventilation, refractory industries, workshops producing in small and medium runs or support production.

It is managed by an **HPC DIGITAL PROCESS HPI III** type CNC control system.

This machine uses the **FINELINE** plasma process. The control console supports the operating approach.

The integration of an extraction table (included in the basic offer) that can be connected to any extraction and/or filtration system and fitted with dross collectors makes its conditions of use maximally safe and healthy. The plate frame is removable, giving easy access while cleaning the containers, or for replacing it to make it easier to load and unload cut pieces.

The 750mm high access to the job has been designed to minimise the distance between the edges of the rails and the lateral ends of the table.

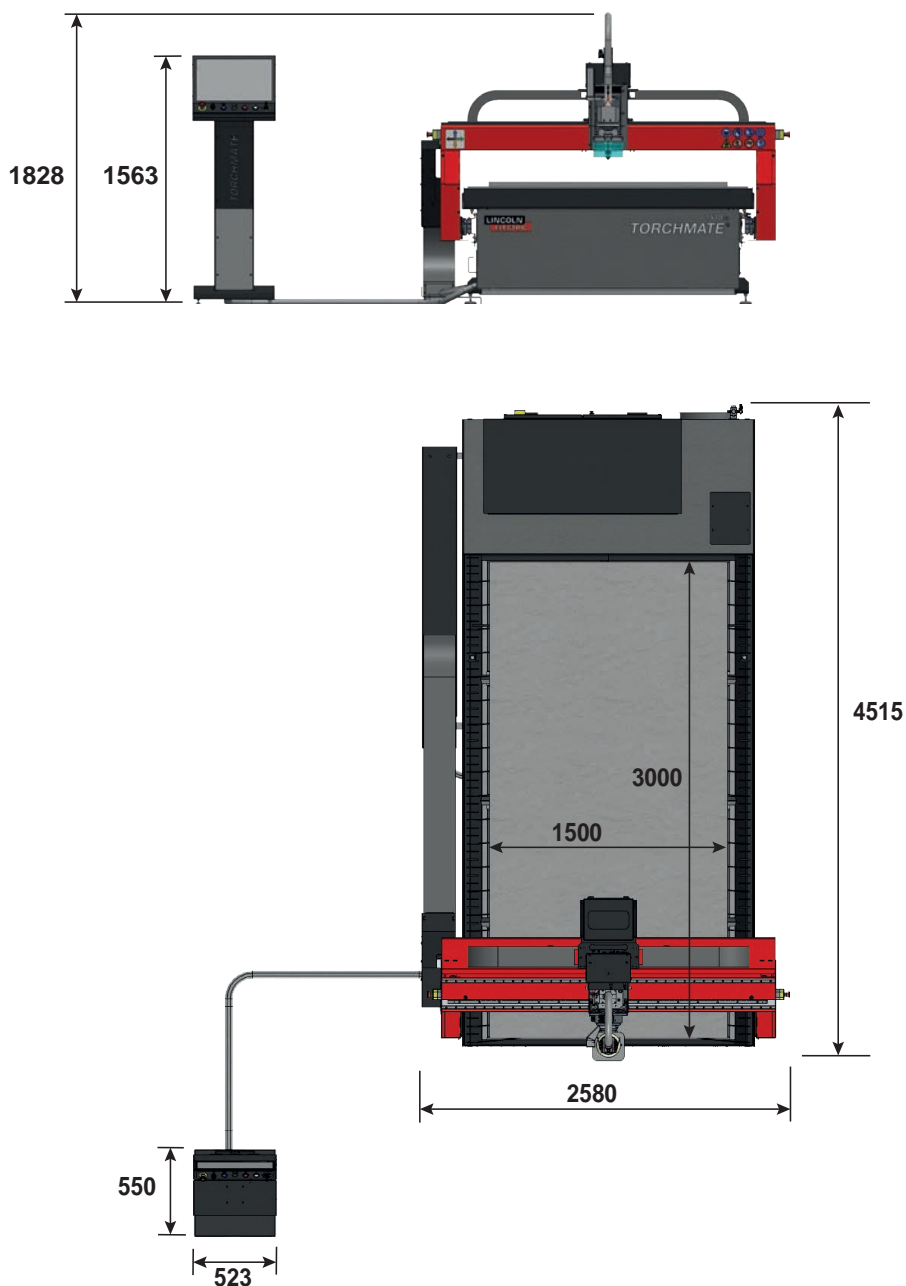



This is a single-piece machine made up of a mechanically welded cutting table, with, on each side, a guide rail with ball slides and a rack to guide and move the beam.

Two guide rails with ball slides and a rack are fixed to the beam, to guide and move the tool carriage.

The high feed speed is 15m/min.

The electrical assembly is located at the rear of the machine. A console contains the screen and numerical control system that controls the machine and the filter.

### 3 - Cutting table

---

This is a mechanically welded box that is placed on the floor, with a Ø350 outlet for connection to an extraction system. For this table, we recommend the use of extraction with filtration that is suited to machine performance.

A removable support frame for the piece to cut, made of expendable plates for plasma cutting, is placed on the box.

The bottom contains dross collectors that are easily removable for cleaning.

The fastening and adjustment systems of the aluminium beam are located on each side, with longitudinal guide rails

The cutting table is made up of several components

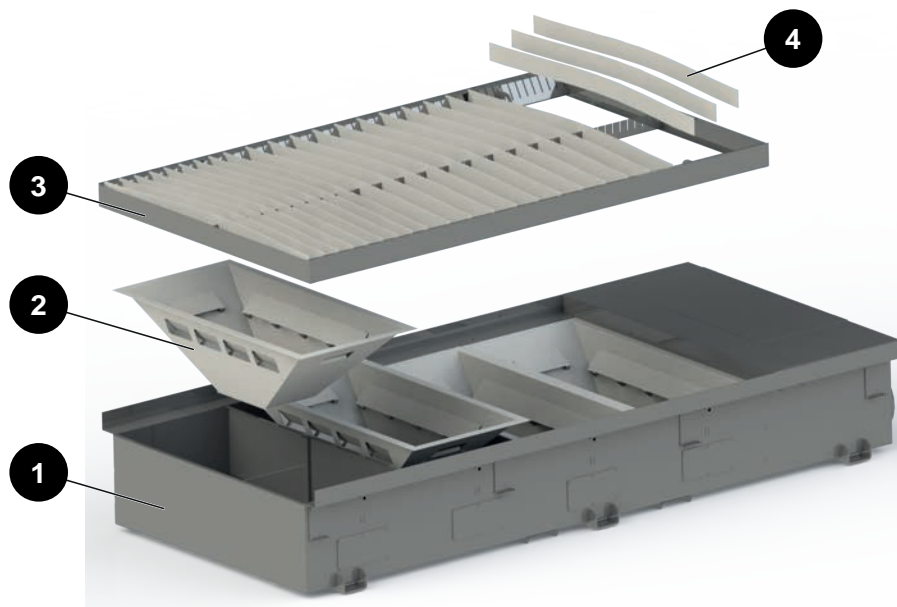

**Base (ref: 1):** Made up of a stable box that supports the load, partitioned into 4 independent extraction compartments that are connected to an extraction tunnel; opening is through hatches with pneumatic cylinders.

These cylinders are actuated by a solenoid valve block controlled by the machine position through the NC system.

**Containers (ref: 2):** 4 containers for collecting cutting dross, which are also used to channel the extraction flow.

**Support frame (ref: 3):** Frame that maintains the expendable plates; it is easy to manipulate to access the dross containers during cleaning.

**Expendable plate (ref: 4):** The expendable plates support the cut material and are easily replaced if they are damaged during cutting.

## 4 - Beam



The beam is made of mechanically welded plates and is machined to receive the transverse guide rails

Adjustable supports with power systems and ball slides for longitudinal guidance are fastened in the lower part.

## 5 - Transverse carriage

This carriage has 4 ball slides **P1** for optimum guidance.

The transverse carriage carries out the following functions:

- Support for transverse power system
- Support for cutting tool.

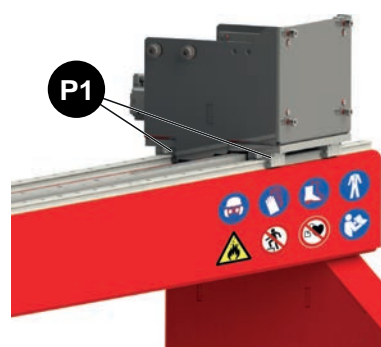

## 6 - Power systems

Transverse power system

Longitudinal power system

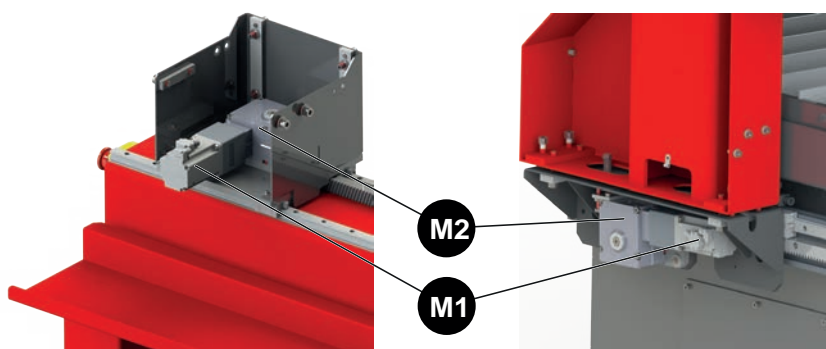

Reference	Description
<b>M1</b>	Brushless power motor
<b>M2</b>	Precision worm and wheel gear + pinion, 20 helical teeth

The control console of the **TORCHMATE™ HD** allows the operator to use the **HPC DIGITAL PROCESS HPI III** CNC control, with all the controls required for starting up the machine and operating the cutting cycle.



Refer to the following:

- technical literature of the **HPC DIGITAL PROCESS III**: 86954995

### 1 - Installation conditions



The machine must be located in accordance with safety standards to keep personnel safe.



**The following conditions must be fulfilled before the equipment is installed.**



Refer to the following:

- supplied electrical diagram
- supplied feed diagram
- supplied layout drawing



#### **Arrangement of cables and hoses**

The customer must provide a means to support and protect cables and flexible hoses from mechanical, chemical or thermal damage.

#### **1.1 - Tools required for installing a machine on site**

- Level offering accuracy of 1/10 per metre
- Tape measure
- Chalk line
- 24-mm open-ended spanner
- 8-mm Allen key

### 2 - Floor preparation



Refer to the following:

- supplied feed diagram
- supplied layout drawing

The floor does not need any particular preparation for installing the machine; however, we recommend a concrete floor for the machine to be satisfactorily stable.

- Continuous concrete slab (200 mm thick) made at least 21 days previously,
- Flatness over the entire area  $\pm 10$  mm,
- 30 mm level difference of screed (5 mm/m max.)



The thickness of the slab and its reinforcement are provided for guidance and must be adapted to the characteristics of the floor.

### 3 - Slinging



While handling the machine with a truck or crane, the operation must be carried out by an individual trained in the use of mechanical handling equipment.



Make sure you have enough space while unpacking your **TORCHMATE™ HD**. A cluttered area increases the risk of tripping and slipping. Dispose of packaging waste based on its type.



**CAUTION:** Protect the sensitive parts while slinging.  
➤ Use the webbing supplied and positioned with the machine.



During any handling operations, the use of appropriate PPE (Personal Protective Equipment) is **mandatory**.



The components of the installation may only be transported using the slinging points provided, with appropriate slinging equipment.

### 4 - Putting in place the TORCHMATE™ 1530 HD



The components of the installation may only be transported using the slinging points provided, with appropriate slinging equipment.

#### 4.1 - Unloading with a travelling crane

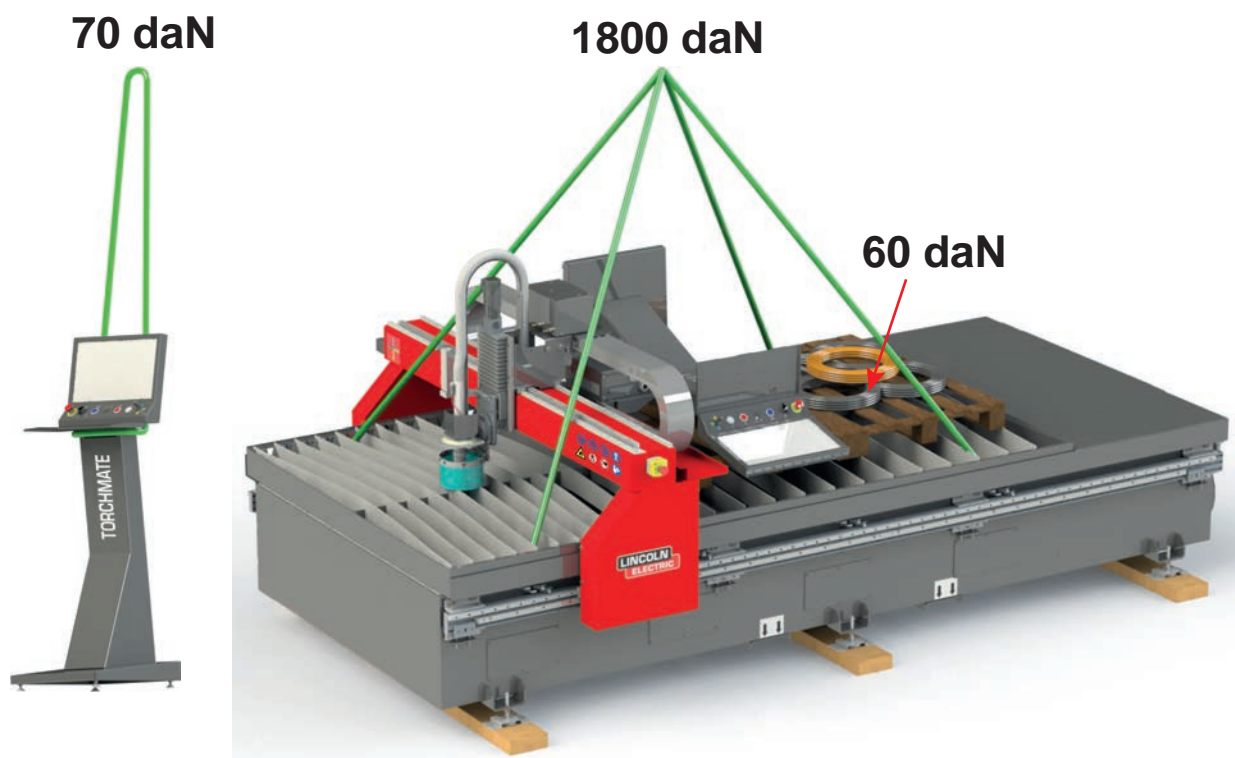

## 4.2 - Unloading with a lift truck

1800 daN

60 daN

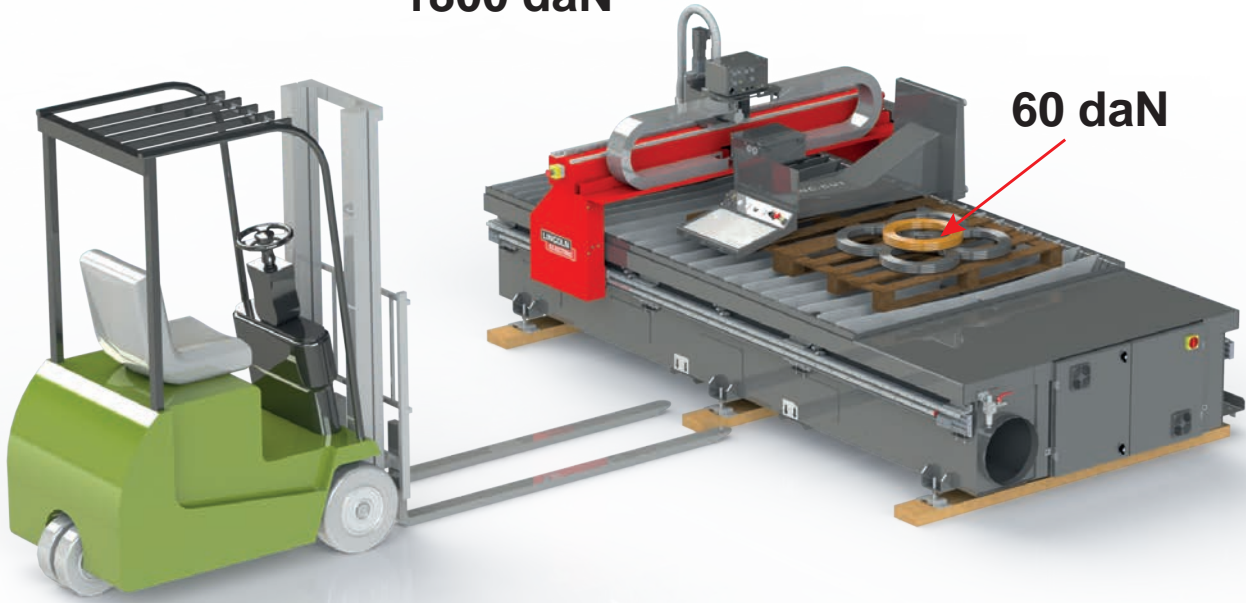

- Unload the console (70 daN)
- Unload the bundle pallet (60 daN) with appropriate lifting equipment,

## 4.3 - Positioning the TORCHMATE 1530HD

- Position the **TORCHMATE™ 1530HD** as indicated in the layout drawing.
- Adjust the machine horizontally with the 6 adjustable feet in the two planes, placing the level on the guide rails or aluminium beams.
- Lock the lock nuts of the adjustable feet

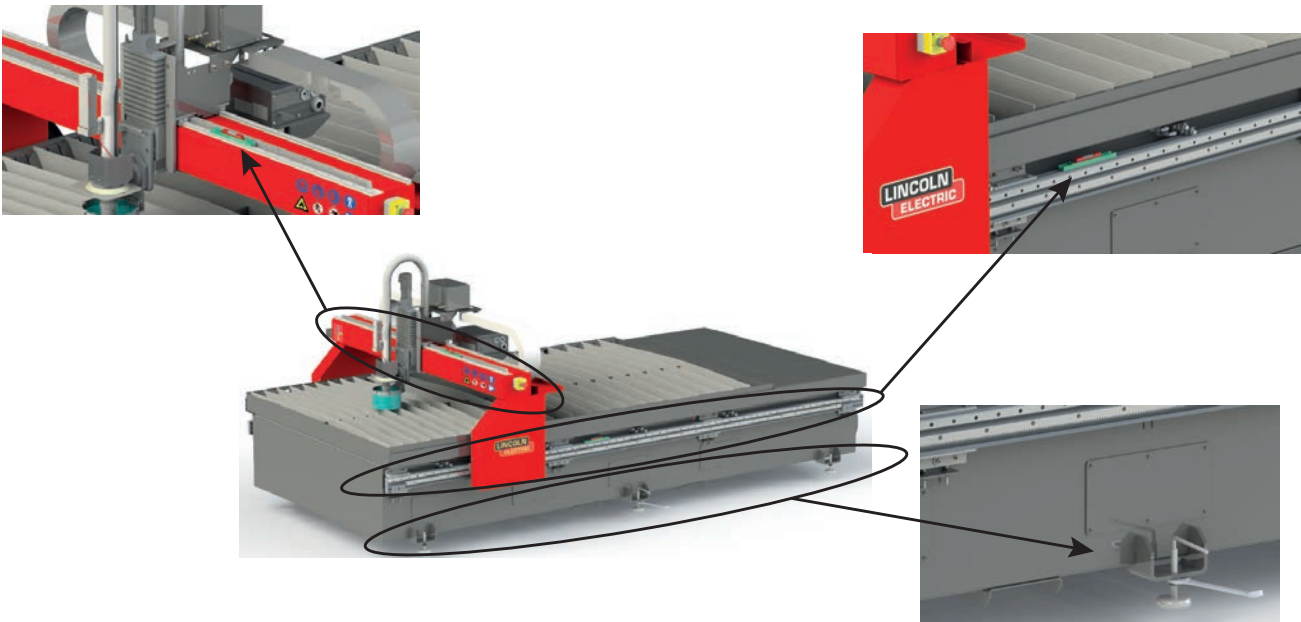

**Important:** do not disengage the motors to move the beam (the horizontal adjustment will be inspected later on when the machine is powered up).

## 5 - Connecting the energy supplies



Refer to the following:

- supplied electrical diagram,
- supplied feed diagram,
- supplied layout drawing,
- technical literature relating to the cutting process.

### 5.1 Connection to the mains



All the operations relating to the installation, such as those for assembly, putting into service and maintenance, are to be carried out by qualified personnel under the control of a responsible technician.



The **TORCHMATE™ 1530HD** must **NECESSARILY** be isolated from all utility supplies when it is connected.  
The disconnection and padlocking of all energy sources is **mandatory**.

The **TORCHMATE™ 1530HD** is supplied with the following:

- 1x 400V - 16A male connector for supplying power to the machine,
- 1x 400V - 125A male connector for supplying power to the power source.

It is to be paired with a female connector of the same type, offering adequate protection (data on the power layout drawing).

The 125A connector has a pilot wire for switching off the upstream supply if the connector is disconnected. That pilot wire must be wired to a contactor that controls the power supply to this connector.



As an option, we can supply disconnecting boxes. Please enquire with us.

### 5.2 Connection to the pneumatic system



The compressed air must be dry, free from impurities or humidity.  
For all other information, please contact the technical staff of **LINCOLN ELECTRIC**.

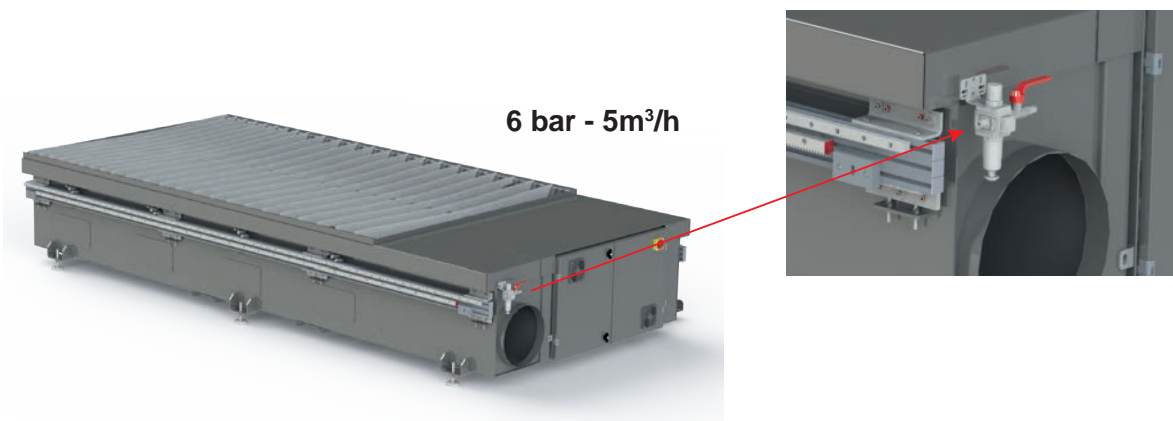

### 5.3 Gas connections



Refer to the following:

- technical literature relating to the cutting process.

1 - Description of controls



Reference	Description
C1	HPC DIGITAL PROCESS III HMI (human machine interface)
C2	Emergency stop
C3	USB port
C4	Button for switch to high speed
C5	Off button
C6	Luminous On button
C7	Manual movement in the direction
C8	Machine disconnecter
C9	Emergency stop
C10	Emergency stop
C11	Intervention mode key (available depending on the machine type)





The **HPC DIGITAL PROCESS III** automatically manages cutting parameters depending on the equipment and the material to cut, associated with part programs..

The workpiece programs are taken from standard shapes or imported from a CAD system

The association of a part program and cutting parameters constitutes a job, which can be saved.

Each program and each job can be copied, edited or exported. There are several ways to cut a part:

- Select a job to make a part that has already been made
- Select a program, then the material and cutting performance
- Select a standard shape, enter its dimensions and then the material and cutting efficiency

(for a new part).



Refer to the following:

- technical literature of the **HPC DIGITAL PROCESS III**: 86954995

You can access document 86954995 of the **HPC DIGITAL PROCESS III** on the HMI (Human Machine Interface) of the machine.

The documentation is accessible on level 2 and level 1 depending on the settings.

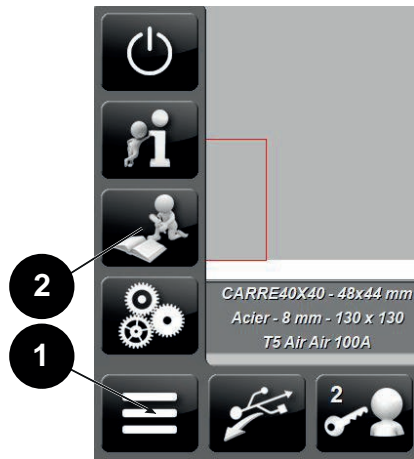

To access the documentation, press **button (1)**, then **button (2)**. Close the PDF file to go back to the HMI screen.

## 2.2 Shutting down

- First press the emergency stop.

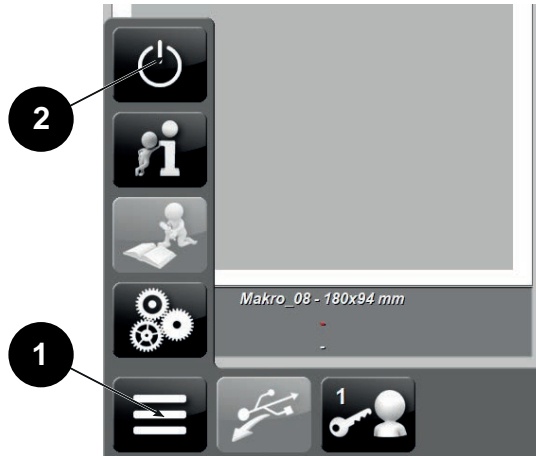

- Press **button (1)** then **button (2)**.

The window below opens



- Press **button (3)** to confirm.
- Wait for the NC system to shut down (black screen).
- Power down the machine by setting the switch **C8** to **O**.
- Switch off all the energy supplies (electricity, air, gas etc.)

1 - Care

For a long and trouble-free life, the machine requires a minimum level of care and maintenance. The frequency of such maintenance is indicated for production in one work shift per day. For higher production rates, increase the maintenance frequencies accordingly. Your maintenance department could photocopy these pages to track maintenance frequencies and times and the operations completed (tick the appropriate box).



Please read the manually carefully before you start any servicing work. Maintenance operations may only be carried out by specialised and qualified individuals. Behaviour that does not comply with the safety instructions provided could lead to major hazards for personnel and damage to property and/or the surroundings.



**Electricity technician:**  
**Qualified operator with the ability to work in normal conditions on electrical parts for regulation, maintenance and repair.**



**Mechanical technician:**  
**Specialised technician authorised to carry out complex and exceptional mechanical operations.**



For operating instructions, adjustments, troubleshooting and spare parts, please refer to the special instructions for safe operating and maintenance.



**CAUTION:** All work at heights (maintenance, troubleshooting etc.) must be carried out with appropriate personnel lifting equipment.



**CAUTION:**  
**BEFORE ANY MAINTENANCE OPERATION, REMEMBER TO:**

- Switch off and lock out the electricity supply.
- Switch off, flush and lock out the gas and compressed air supplies.



**CAUTION:** All work at heights (maintenance, troubleshooting etc.) on the machine must be carried out with appropriate personnel lifting equipment.



**IMPORTANT:** "Do not remove the Nylstop nuts from the fastening screws of the guards: they keep them captive"



**WARNING:** While handling sheets, take the necessary precautions to avoid impacts on the machine and the rolling tracks. Impacts on any of the elements can lead to squareness faults or the malfunctioning of the electrical shaft and therefore incorrect cutting of the workpieces.



Before starting up the machine, make sure that the replaced parts are perfectly installed and that the tools used are removed from the machine. Make sure that each safety device is in good condition and legible.

## 1.1 Maintenance schedule





This schedule must **absolutely** be followed.  
We recommend putting in place a traced system for tracking all your maintenance operations.

Sub-assembly	Component	Type of inspection	Action	Frequency			Step
				1 week	1 month	1 year	
Guiding	Rack		Cleaning	X			A
Guiding	Rail		Cleaning	X			B
TORCHMATE™ HD			Cleaning	X			C
Control	<b>HPC DIGITAL PROCESS III</b>		Cleaning	X			D
Electrical	Bundle	Visual			X		E
Guiding	Rail	Lubrication	Lubrication		X		F
Table			Cleaning		X		G

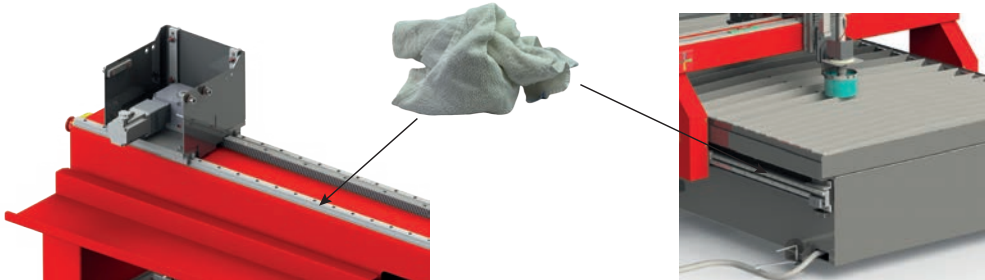
Step	Operation	OK	NOK
<b>A</b>	<u>Rack guidance</u>	✓	✗
	<ul style="list-style-type: none"> <li>Brush the racks to remove any adhering material. (If needed, spray Molykote 3402 C coating (Dow Corning) on the sides of the racks.)</li> </ul> 		

Step	Operation	OK	NOK
<b>B</b>	<u>Guide rail guidance</u>	✓	✗
	<ul style="list-style-type: none"> <li>Regular cleaning of all the guide rails of the beam and the cutting table. Clean with a dry cloth or a cloth moistened with solvent, such as solvent naphtha or white spirit.</li> </ul> 		



Step	Operation	OK	NOK
<b>C</b>	<b>TORCHMATE™ HD</b>	✓	✗
	<ul style="list-style-type: none"> <li>Overall cleaning of the machine to eliminate cutting dust</li> </ul> 		

Step	Operation	OK	NOK
<b>D</b>	<b>HPC DIGITAL PROCESS III control</b>	✓	✗
	<ul style="list-style-type: none"> <li>Cleaning the screen: <ul style="list-style-type: none"> <li>* Switch off the power to the machine</li> <li>* Use window cleaner applied on a clean cloth or sponge.</li> <li>* Never apply cleaner directly on the touch screen.</li> <li>* Do not use alcohol (methyl, alcohol or isopropyl alcohol) or thinner, benzene or other strong solvent.</li> <li>* Do not clean the screen with a cloth or a sponge which may scratch the surface</li> </ul> </li> </ul> 		

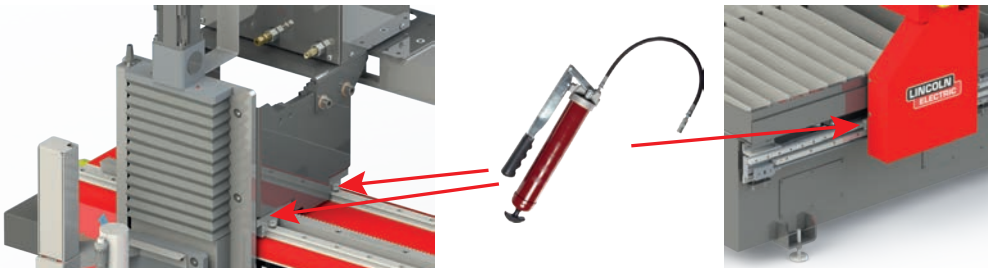
Step	Operation	OK	NOK
<b>E</b>	<b>Electrical bundle</b>	✓	✗
	<ul style="list-style-type: none"> <li>Check the condition of all the electrical cables, particularly close to the cutting tools and in the cable drag chain (change them if required).</li> </ul>		

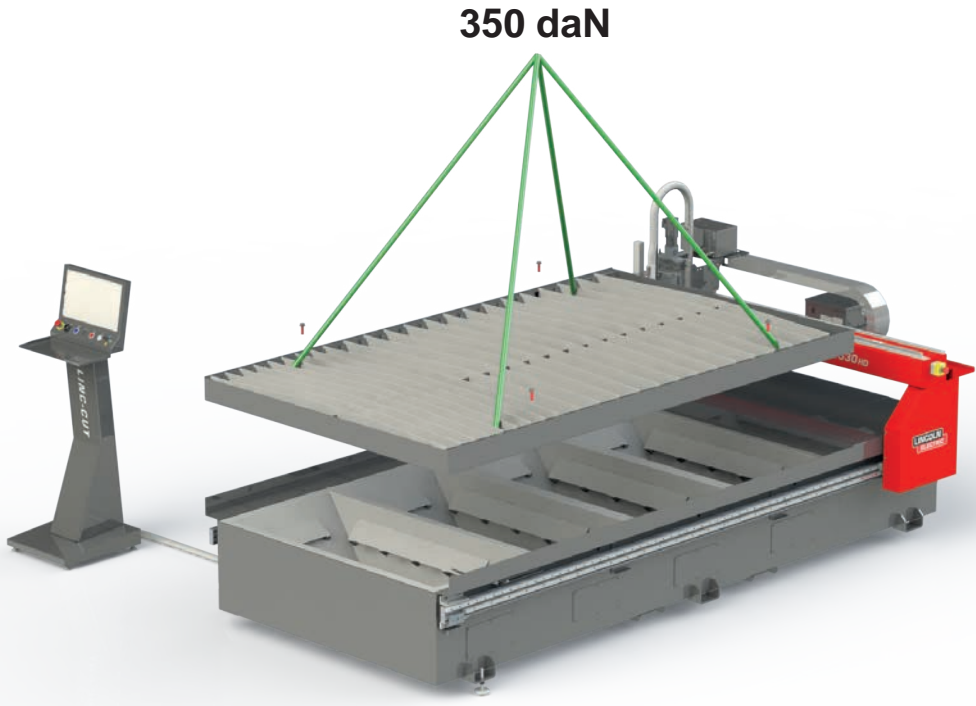
Step	Operation	OK	NOK
<b>F</b>	Rail guidance	✓	✗
	<ul style="list-style-type: none"> <li>Lubricate the ball slides on each axis (4 on the transverse carriage and 4 on the machine X axis). We recommend the use of NLGI grade 2 lithium soap grease (e.g. Wynn's type HPG, Hafa type Mouwan Grease) Lubricate each ball slide at the operating temperature by moving it. It is better to lubricate several times with small quantities of lubricant.</li> </ul> 		

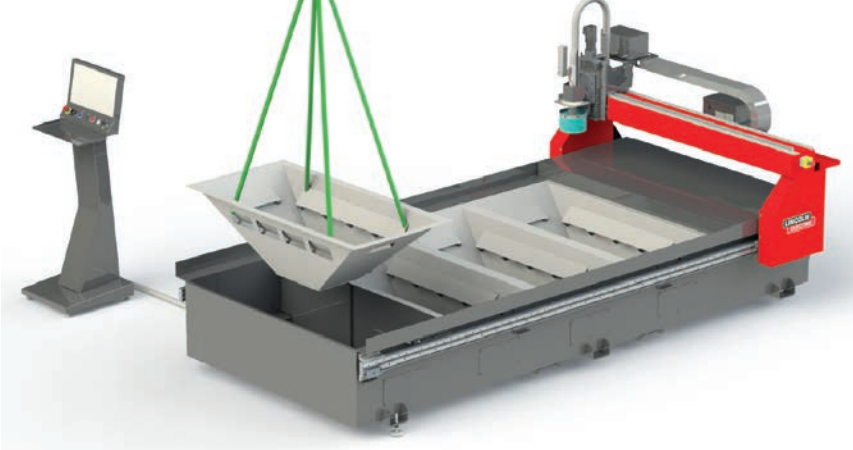
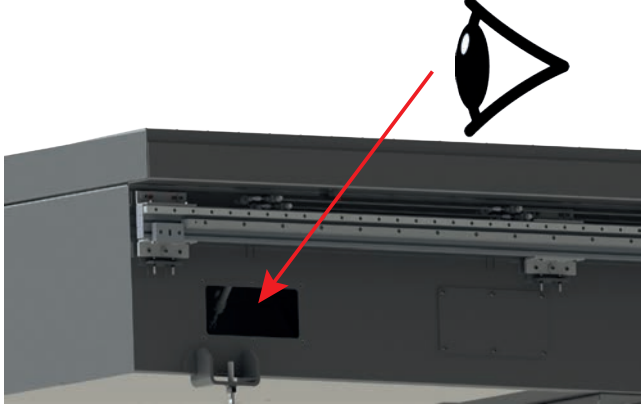
Step	Operation	OK	NOK
<b>G</b>	Cutting table	✓	✗
	<ul style="list-style-type: none"> <li>Cleaning the cutting table For these operations, the use of lifting chains with hooks with safety locks is strongly recommended. The frequency of these operations may vary depending on the use of the machine Empty the containers before they are too full. The dross must not obstruct extraction.</li> <li>* Move the machine to the rear position Take off the 4 M16 screws (24-mm spanner) holding the frame. Lift the frame with the expendable plates by fastening the 4-leg chain to the 4 lifting eyes (take off the expendable plates if necessary).</li> </ul> <p style="text-align: center;"><b>350 daN</b></p> 		

Step	Operation	OK	NOK
G	Cutting table	✓	✗
	<p data-bbox="304 185 1214 275">* Lift the containers (55 daN when empty) one after the other to empty them. Check the conditions of the extraction hatches. Check the closing and opening of the hatches (see procedure in HMI).</p> <div data-bbox="288 331 1145 869"> <p data-bbox="544 331 655 365" style="text-align: center;"><b>55 daN</b></p>  </div> <p data-bbox="304 891 1214 947">* Take off the 4 lateral inspection ports to check the condition of the cylinders and air pipes.</p> <div data-bbox="395 1003 1038 1406">  </div> <div data-bbox="220 1462 1217 1574" style="border: 1px solid red; padding: 5px;">  <p data-bbox="368 1485 1201 1552"><b>Mind the risk of catching while adjusting the table hatches. Readjusting the flow limiters could result in a sudden movement.</b></p> </div>		



## 2 - Troubleshooting



Refer to the following:

- electrical diagram,
- technical literature of the **HPC DIGITAL PROCESS III**: 86954995,
- technical literature of the different options.



**Reminder: all work is to be carried out by approved and trained personnel.**

## 3 - HMI alarm

List of most common alarms relating to the machine displayed on the HMI:

Fault	Probable causes	Possible remedies
<b>29:</b> An axis limit has been reached	A position in the program has overrun the software limits defined for the machine.	Modify the program or the part program zero point.
<b>64:</b> Lag error axis (X, Y or W). Lag exceeds the limit!	The axis position is different from its control in an excessively large value (due to an impact, for instance)	Set the gantry straight (power off) and set the zero point once again.
<b>98:</b> Risk of collision: negative radius or change in direction in block no. xx	Kerf compensation is greater than the radius of the part	Correct the program or the kerf compensation.
<b>199:</b> NC block incorrect. NC address error (X or Y) Only a reset is possible	A standard program has been started without defining its zero point.	Define the program zero point (see instructions 8695 4995)
<b>207:</b> Collision hazard, change in direction at block no.	Kerf compensation is greater than the space between cuts	Correct the program or the kerf compensation.
<b>288:</b> No tool has been selected	The program is a standard shape and requires tool selection by the HMI	Select the tool before starting the program
<b>960:</b> Axis (X or Y): Variable drive alert - Axis at positive limit!	The + electrical limit switch has been reached	Jog away the axis in the opposite direction, and clear the alarm.
<b>961:</b> Axis (X or Y): Variable drive alert - Axis at negative limit!	The - electrical limit switch has been reached	Jog away the axis in the opposite direction, and clear the alarm.
<b>1001:</b> The emergency stop is active!	An emergency stop has been engaged	Re-engage the emergency stop buttons and put back into service.
<b>1003:</b> The CNC has been stopped by an emergency stop	The numerical control has experienced a serious error during operation	Check for additional errors and put back into service
<b>1004, 1005, 1006:</b> The variable drive of axis xx is not ready "DRIVEON"	The power supply of the variable drive is missing EtherCAT problem	Check the fuse F2 and enabling of KM2 upon starting up. Check the condition of the LEDs on the variable drive. (on LM and T variable drive: 2 flashing green LEDs, on LE variable drive: 1 flashing green LED.)
<b>1011:</b> Cycle stop for head collision. Jog in limited speed	Torch impact (plasma) or probe impact (oxy cutting)	Jog away the tool, restart the program

<b>1012:</b> Please apply a machine emergency stop before exiting this application	The emergency stop must be enabled when the NC is switched off	Enable the emergency stop and switch off the machine
<b>1014:</b> Please apply a machine emergency stop	The emergency stop must be enabled when the machine setup is validated.	Apply the emergency stop before validating the setup, validate the setup and put the machine back into service
<b>1015:</b> Job change error	A job change error is requested while a program is active.	Reset the program before asking for a job change.
<b>1022:</b> Air supply fault	Air pressure low on the machine (not related to process gas).	Check that the disconnecting valve is open. Adjust the air pressure to the required pressure. Possibly adjust the air pressure switch.
<b>1023:</b> Door open fault alarm	Case of Alphasome: the door for accessing the process has been left open.	Close the door.
<b>1040:</b> Wait for the cycle start to set the zero point	The machine has a machine zero point setting, activated by a cycle start	Press the Cycle start button
<b>1041:</b> Zero point setting in progress	The zero point cycle is in progress.	Wait for the zero point cycle to be completed.
<b>1042:</b> Zero point completed	The machine zero point cycle is complete	Clear the warning
<b>1053 to 1068:</b> The selected tool does not exist	The part program is asking for a process not defined in the setup	Correct the part program (code S)
<b>1069:</b> Request for a undefined process	The part program is asking for an unknown process	Correct the part program (code S)
<b>1071:</b> No operating feedback from the filter	There is no operating feedback from the filter since more than 30 seconds, but a cut has been requested. Process stopped	Start up the extraction system and check if it is working correctly. Restart the program
<b>01072:</b> Standing by for extraction feedback	There is no operating feedback from the filter, but a cut has been requested. Program paused (if not started) or stopped at the next cut.	Start up the extraction system and check if it is working correctly.
<b>01073:</b> Key in process adjustment mode, movements forbidden	The process key is in adjustment mode.	Turn the key to cycle mode to allow movements.
<b>01074:</b> Safety light curtain crossed, movements forbidden	Something has cut one of the safety light curtains.	Check that there is no risk. Put the safety light curtains back in service (blue button on the console) to allow movements.
<b>1151:</b> Standing by for cycle start for new job	The job change request must be followed by a cycle start	Press the Cycle start button
<b>1152:</b> Standing by for cycle start for RUSH program	The RUSH request must be followed by a cycle start	Press the Cycle start button
<b>1154:</b> Standing by for cycle start for movement	The movement request (positioning laser, for example) must be followed by a cycle start	Press the Cycle start button



## 4 - Spare parts

### Ordering procedure:

Almost all the parts of a machine or installation are referenced in the photographs and sketches.

### The descriptive tables contain three types of item:

- items normally held in stock: ✓
- items not held in stock: ✗
- articles upon request: no reference

(For such parts, please complete the list of parts page and send us a copy. In the Order column, state the number of parts required and indicate the type and number of your equipment.)

For items referenced in the photographs or sketches but not included in the tables, please send us a copy of the relevant page and highlight the relevant reference.

### Example:

✓	normally held in stock.
✗	not in stock
	upon request.

Ref.	Part no	Stock	Order	Description
E1	W000XXXXXX	✓		Machine interface board
G2	W000XXXXXX	✗		Flow meter
A3	P9357XXXX			Printed front plates

- While ordering parts, please indicate the quantity and note the number of your machine in the box above.

 Type <input type="text"/> Matricule <input type="text"/>	TYPE:
	Number:

#### 4.1 Longitudinal and transverse power systems

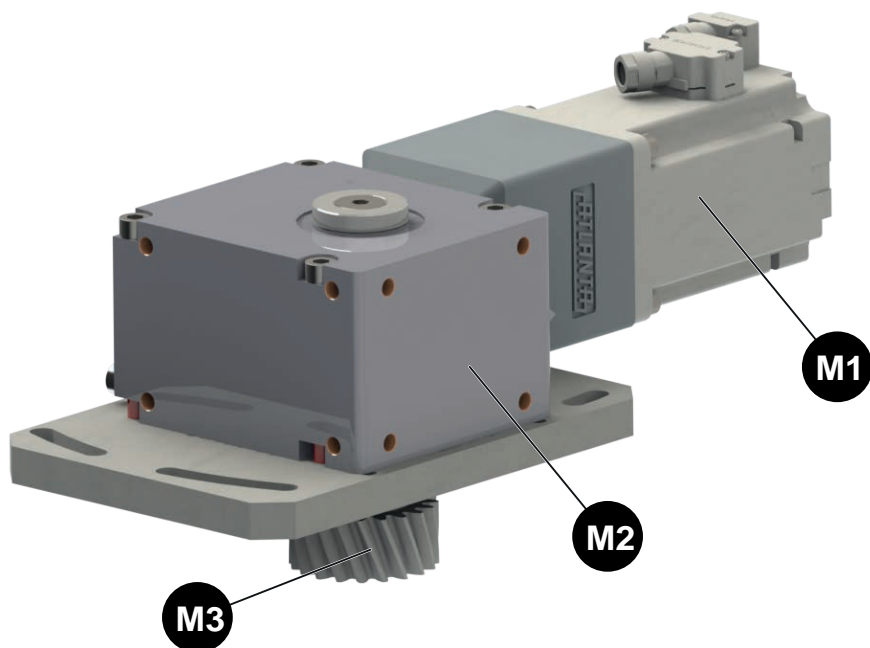

✓	normally held in stock.
✗	not in stock upon request.

Ref.	Part no	Stock	Order	Description
M1	AS-CS-07006574	✓		Brushless motor, 400W <i>Innovance technology: MS1H1-40B30CB-A331Z-INT</i>
M2	AS-CS-07004221	✗		Worm and wheel gear <i>Atlanta Neugart France: E Servo A32 I19.5</i>
M3	AS-CS-07006575	✓		M2 shaft pinion - 20 teeth - helical

- While ordering parts, please indicate the quantity and note the number of your machine in the box above.

CE Type <input type="text"/> Matricule <input type="text"/>	TYPE:
	Number:

## 4.2 Guidance and transmission

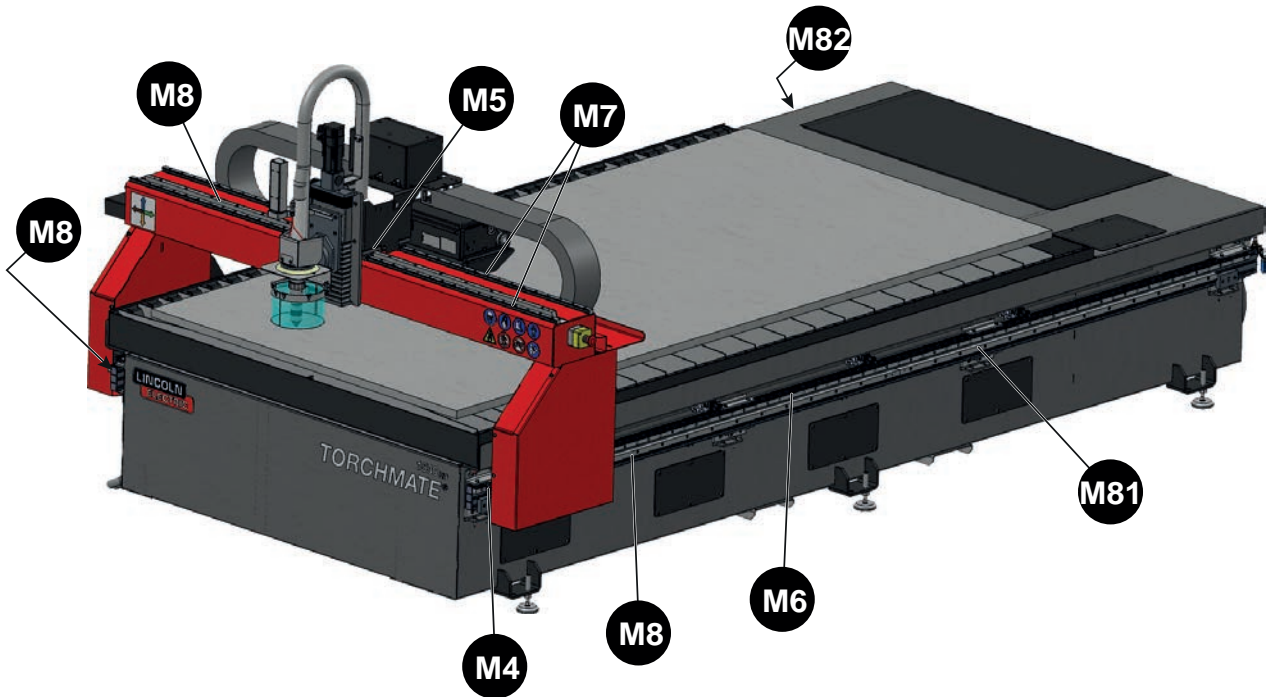

✓	normally held in stock.
✗	not in stock upon request.

Ref.	Part no	Stock	Order	Description
M4	AS-CS-C6202765	✓		1 set of 7 longitudinal guides <i>NTNSNR part no: LGBXS20BNFFNZ1-N</i>
M5	W000400296	✓		1 set of 7 transverse guides <i>NTNSNR part no: LGBXS20BSFFNZ1-N</i>
M6	PC6202755			1 longitudinal guide rail <i>NTNSNR part no: LGBR20L03900N-1-0-30.0N</i>
M7	PC6202759			1 transfer guide rail <i>NTNSNR part no: LGBR20L02100N-1-0-30.0N</i>
M8	P07006534			1 M2 helical rack, length: 2000 mm
M81	P07006535			1 M2 helical rack, length: 1600 mm right
M82	P07006536			1 M2 helical rack, length: 1600 mm left

- While ordering parts, please indicate the quantity and note the number of your machine in the box above.

CE Type <input type="text"/> Matricule <input type="text"/>	TYPE:
	Number:

### 4.3 Cutting table

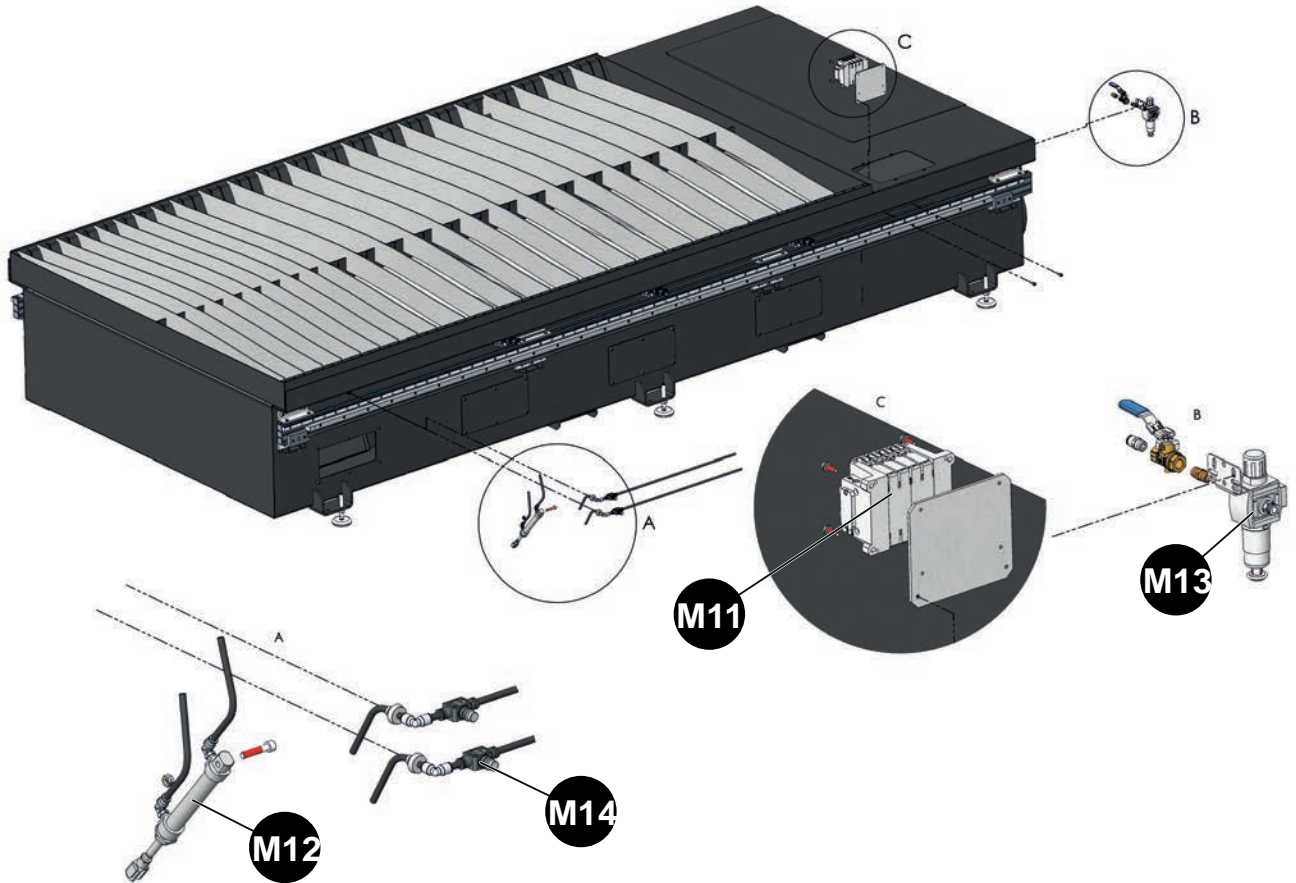

✓	normally held in stock.
✗	not in stock
	upon request.

Ref.	Part no	Stock	Order	Description
M11	AS-CS-C5900198	✓		1 assembly of 4 valves, 5/2 Ø8 ASC0 JOUCOMATIC, part no: A933A2001145101
M12	AS-CS-C5904157	✗		1 equipped cylinder - Ø20 - Course:100 ASC0 JOUCOMATIC, part no: R480323147
M13	AS-CS-C5902425	✓		1 regulator filter with pressure gauge - Ø8 - 10000 nl/min ASC0 JOUCOMATIC, part no: R480323147
M14	AS-CS-C5900525	✓		1 flow regulator ASC0 JOUCOMATIC, part no: R412005456
	AS-CS-C6101168	✗		Anti-spark tubing Ø6x8 black - 15 metres PARKER part no: 1025P08V01

- While ordering parts, please indicate the quantity and note the number of your machine in the box above.

CE Type <input type="text"/> Matricule <input type="text"/>	TYPE:
	Number:

#### 4.4 Electrical components

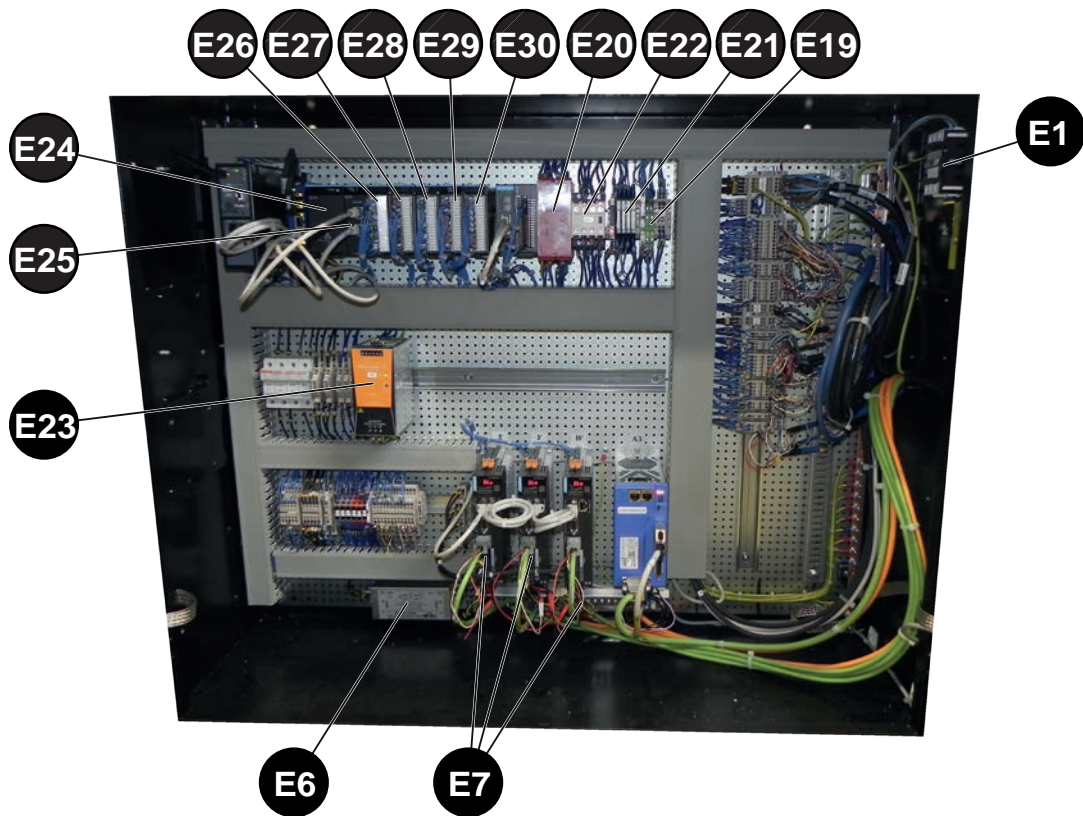



✓	normally held in stock.
✗	not in stock
	upon request.

Ref.	Part no	Stock	Order	Description
E1	W000140748	✓		Sectioning switch, 3P 25A <i>Rexel: LEG022102</i>
E6	AS-CS-C5608039	✗		15A electrical filter <i>Direct SA: FN2020106</i>
E7	AS-CS-C5700299	✓		Brushless variator, 2.8A - 230V - 400W <i>Innovance Technology France: 01052586 + Option Superca</i>
E8	PC5706133			Transformer, 230V-400V / 220V+24V - 3500VA
E19	AS-CS-C5701725	✗		Flashing relay, 24VAC/DC - 1RT - 6A <i>Elec System: FIN39.91.0.024.0060</i>
E20	W000383972	✓		Safety module <i>Schneider Electric France: XPSUAT13A3AP</i>
E21	W000365963	✗		Relay, 24VAC/DC - 6A - 1RT <i>Weidmuller: 1122890000</i>
E22	W000383699	✗		Contacteur, 3F O+F 24VCCBD <i>Schneider Electric France: LC1D12BD</i>
	AS-CS-C5705350	✗		Additional contactor 3F+1O <i>Schneider Electric France: LADN31</i>
E23	W000385169	✓		Power supply, 230V/24VDC/10A <i>Weidmuller: 1469490000</i>
E24	AS-CS-C5703329	✓		1: GL10 power supply module <i>(Inovance technology: 01440196)</i>
E25	AS-CS-C5703330	✓		1: GL10 EtherCAT module <i>(Inovance technology: 01440194)</i>
E26	AS-CS-C5703324	✓		1: Module, 16I On/Off GL10 <i>(Inovance technology: 01440198)</i>
E27	AS-CS-C5703325	✓		1: Module, 16O On/Off GL10 <i>(Inovance technology: 01440199)</i>
E28	AS-CS-C5703326	✓		1: Module, 4I, Analogue GL10 <i>(Inovance technology: 01440197)</i>
E29	AS-CS-C5703327	✓		1: Module, 4O, Analogue GL10 <i>Inovance technology: 01440192)</i>
E30	AS-CS-C5703331	✓		1: Module, 16O, On/Off relay, GL10 <i>Inovance technology: 01440193)</i>
E31	AS-CS-07087072	✗		CPU PA9000 CNC W10 + Standard dongle
E32	AS-CS-C5703732	✓		21" touch screen - 16/9 + power supply, 230V

- While ordering parts, please indicate the quantity and note the number of your machine in the box above.

 Type <input type="text"/> Matricule <input type="text"/>	TYPE:
	Number:

