

# LF 52D

## OPERATOR'S MANUAL



ENGLISH





**THANKS!** For having chosen the QUALITY of the Lincoln Electric products.

- Please Examine Package and Equipment for Damage. Claims for material damaged in shipment must be notified immediately to the dealer.
- For future reference record in the table below your equipment identification information. Model Name, Code & Serial Number can be found on the machine rating plate.

Model Name:	
.....	
Code & Serial number:	
.....	.....
Date & Where Purchased:	
.....	.....

## ENGLISH INDEX

Technical Specifications.....	1
Electromagnetic Compatibility (EMC).....	2
Safety.....	3
Introduction.....	5
Installation and Operator Instructions.....	5
WEEE.....	13
Spare Parts.....	13
Authorized Service Shops Location.....	13
Electrical Schematic.....	13
Accessories.....	14
Connection Diagram.....	16
Dimension Diagram.....	18

# Technical Specifications

NAME		INDEX	
LF 52D		K14335-1	
INPUT			
Input Voltage U <sub>1</sub>	Input Amperes I <sub>1</sub>	EMC Class	
40Vdc	4Adc	A	
RATED OUTPUT			
Duty Cycle 40°C (based on a 10 min. period)		Output Current	
100%		420A	
60%		500A	
OUTPUT RANGE			
Welding Current Range		Peak Open Circuit Voltage	
5 ÷ 500A		113Vdc or Vac peak	
DIMENSION			
Weight	Height	Width	Length
17 kg	516 mm	302 mm	642 mm
WIRE FEED SPEED RANGE / WIRE DIAMETER			
WFS Range	Drive Rolls	Drive roll diameter	
1.5 ÷ 22 m/min	4	Ø37	
Solid Wires	Aluminum Wires	Cored Wires	
0.8 ÷ 1.6 mm	1.0 ÷ 1.6 mm	0.9 ÷ 1.6 mm	
OTHERS			
Protection Rating		Maximum Gas Pressure	
IP23		0,5 MPa (5 bar)	
Operating Temperature		Storage Temperature	
from -10°C to +40°C		from -25°C to 55°C	

# Electromagnetic Compatibility (EMC)

01/11

This machine has been designed in accordance with all relevant directives and standards. However, it may still generate electromagnetic disturbances that can affect other systems like telecommunications (telephone, radio, and television) or other safety systems. These disturbances can cause safety problems in the affected systems. Read and understand this section to eliminate or reduce the amount of electromagnetic disturbance generated by this machine.



This machine has been designed to operate in an industrial area. To operate in a domestic area it is necessary to observe particular precautions to eliminate possible electromagnetic disturbances. The operator must install and operate this equipment as described in this manual. If any electromagnetic disturbances are detected the operator must put in place corrective actions to eliminate these disturbances with, if necessary, assistance from

Lincoln Electric.

Before installing the machine, the operator must check the work area for any devices that may malfunction because of electromagnetic disturbances. Consider the following.

- Input and output cables, control cables, and telephone cables that are in or adjacent to the work area and the machine.
- Radio and/or television transmitters and receivers. Computers or computer controlled equipment.
- Safety and control equipment for industrial processes. Equipment for calibration and measurement.
- Personal medical devices like pacemakers and hearing aids.
- Check the electromagnetic immunity for equipment operating in or near the work area. The operator must be sure that all equipment in the area is compatible. This may require additional protection measures.
- The dimensions of the work area to consider will depend on the construction of the area and other activities that are taking place.

Consider the following guidelines to reduce electromagnetic emissions from the machine.

- Connect the machine to the input supply according to this manual. If disturbances occur it may be necessary to take additional precautions such as filtering the input supply.
- The output cables should be kept as short as possible and should be positioned together. If possible connect the work piece to ground in order to reduce the electromagnetic emissions. The operator must check that connecting the work piece to ground does not cause problems or unsafe operating conditions for personnel and equipment.
- Shielding of cables in the work area can reduce electromagnetic emissions. This may be necessary for special applications.

## **WARNING**

EMC classification of this product is class A in accordance with electromagnetic compatibility standard EN 60974-10 and therefore the product is designed to be used in an industrial environment only.

## **WARNING**











The Class A equipment is not intended for use in residential locations where the electrical power is provided by the public low-voltage supply system. There can be potential difficulties in ensuring electromagnetic compatibility in those locations, due to conducted as well as radio-frequency disturbances.









## WARNING

This equipment must be used by qualified personnel. Be sure that all installation, operation, maintenance and repair procedures are performed only by qualified person. Read and understand this manual before operating this equipment. Failure to follow the instructions in this manual could cause serious personal injury, loss of life, or damage to this equipment. Read and understand the following explanations of the warning symbols. Lincoln Electric is not responsible for damages caused by improper installation, improper care or abnormal operation.

	<p><b>WARNING:</b> This symbol indicates that instructions must be followed to avoid serious personal injury, loss of life, or damage to this equipment. Protect yourself and others from possible serious injury or death.</p>
	<p><b>READ AND UNDERSTAND INSTRUCTIONS:</b> Read and understand this manual before operating this equipment. Arc welding can be hazardous. Failure to follow the instructions in this manual could cause serious personal injury, loss of life, or damage to this equipment.</p>
	<p><b>ELECTRIC SHOCK CAN KILL:</b> Welding equipment generates high voltages. Do not touch the electrode, work clamp, or connected work pieces when this equipment is on. Insulate yourself from the electrode, work clamp, and connected work pieces.</p>
	<p><b>ELECTRICALLY POWERED EQUIPMENT:</b> Turn off input power using the disconnect switch at the fuse box before working on this equipment. Ground this equipment in accordance with local electrical regulations.</p>
	<p><b>ELECTRICALLY POWERED EQUIPMENT:</b> Regularly inspect the input, electrode, and work clamp cables. If any insulation damage exists replace the cable immediately. Do not place the electrode holder directly on the welding table or any other surface in contact with the work clamp to avoid the risk of accidental arc ignition.</p>
	<p><b>ELECTRIC AND MAGNETIC FIELDS MAY BE DANGEROUS:</b> Electric current flowing through any conductor creates electric and magnetic fields (EMF). EMF fields may interfere with some pacemakers, and welders having a pacemaker shall consult their physician before operating this equipment.</p>
	<p><b>CE COMPLIANCE:</b> This equipment complies with the European Community Directives.</p>
 <p><small>Optical radiation emission Category 2 (EN 12191)</small></p>	<p><b>ARTIFICIAL OPTICAL RADIATION:</b> According with the requirements in 2006/25/EC Directive and EN 12198 Standard, the equipment is a category 2. It makes mandatory the adoption of Personal Protective Equipments (PPE) having filter with a protection degree up to a maximum of 15, as required by EN169 Standard.</p>
	<p><b>FUMES AND GASES CAN BE DANGEROUS:</b> Welding may produce fumes and gases hazardous to health. Avoid breathing these fumes and gases. To avoid these dangers the operator must use enough ventilation or exhaust to keep fumes and gases away from the breathing zone.</p>
	<p><b>ARC RAYS CAN BURN:</b> Use a shield with the proper filter and cover plates to protect your eyes from sparks and the rays of the arc when welding or observing. Use suitable clothing made from durable flame-resistant material to protect you skin and that of your helpers. Protect other nearby personnel with suitable, non-flammable screening and warn them not to watch the arc nor expose themselves to the arc.</p>

	<p><b>WELDING SPARKS CAN CAUSE FIRE OR EXPLOSION:</b> Remove fire hazards from the welding area and have a fire extinguisher readily available. Welding sparks and hot materials from the welding process can easily go through small cracks and openings to adjacent areas. Do not weld on any tanks, drums, containers, or material until the proper steps have been taken to insure that no flammable or toxic vapors will be present. Never operate this equipment when flammable gases, vapors or liquid combustibles are present.</p>
	<p><b>WELDED MATERIALS CAN BURN:</b> Welding generates a large amount of heat. Hot surfaces and materials in work area can cause serious burns. Use gloves and pliers when touching or moving materials in the work area.</p>
	<p><b>CYLINDER MAY EXPLODE IF DAMAGED:</b> Use only compressed gas cylinders containing the correct shielding gas for the process used and properly operating regulators designed for the gas and pressure used. Always keep cylinders in an upright position securely chained to a fixed support. Do not move or transport gas cylinders with the protection cap removed. Do not allow the electrode, electrode holder, work clamp or any other electrically live part to touch a gas cylinder. Gas cylinders must be located away from areas where they may be subjected to physical damage or the welding process including sparks and heat sources.</p>
	<p><b>MOVING PARTS ARE DANGEROUS:</b> There are moving mechanical parts in this machine, which can cause serious injury. Keep your hands, body and clothing away from those parts during machine starting, operating and servicing.</p>
	<p><b>SAFETY MARK:</b> This equipment is suitable for supplying power for welding operations carried out in an environment with increased hazard of electric shock.</p>

The manufacturer reserves the right to make changes and/or improvements in design without upgrade at the same time the operator's manual.

# Introduction

LF 52D is digital wire feeder which has been designed to work with Lincoln Electric power sources:

- POWERTEC® i350S,
- POWERTEC® i420S,
- POWERTEC® i500S,
- SPEEDTEC® 400SP,
- SPEEDTEC® 500SP,
- FLEXTEC® 350x,
- FLEXTEC® 500x.

The CAN protocol is used for communication between the power source and the wire feeder. All signals from the power source are displayed on the User Interface located in the wire feeder machine.

Set of power source and wire feeder allow welding in listed processes:

- GMAW (MIG/MAG),
- FCAW,
- SMAW (MMA),
- GTAW,
- CAG.

The complete package contains:

- Wire feeder.
- USB memory with operator's manual.
- Easy Start.

Recommended equipment, which can be bought by user, was mentioned in the chapter "Accessories".

# Installation and Operator Instructions

Read this entire section before installation or operation of the machine.

## Exploitation conditions

This machine can operate in harsh environments. However, it is important to use the following simple preventive measures that will ensure its long life and reliable operation:

- Do not place or operate this machine on a surface with an incline higher than 15° from horizontal.
- Do not use this machine for pipe thawing.
- This machine must be located where there is free circulation of clean air without restrictions for air movement. Do not cover the machine with paper, cloth or rags when switched on.
- Dirt and dust that can be drawn into the machine should be kept away from the item.
- This machine has a protection rating of IP23. Keep it dry when possible and do not place it on a wet ground or in puddles.
- Locate the machine away from a radio controlled machinery. Normal operation may adversely affect the operation of a nearby radio controlled machinery, which may result in injury or equipment damage. Read the section on electromagnetic compatibility in this manual.
- Do not operate in areas with an ambient temperature greater than 40°C.

## Duty cycle and Overheating

The duty cycle of a welding machine is the percentage of time in a 10 minute cycle at which the welder can operate the machine at rated welding current.

Example: 60% duty cycle



Welding for 6 minutes.

Break for 4 minutes.

Excessive extension of the duty cycle will cause the thermal protection circuit to activate.

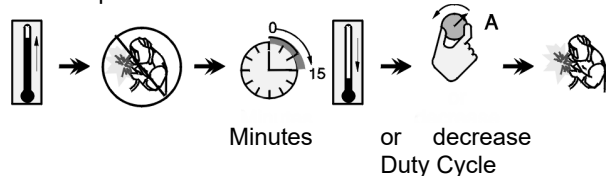

## Input Supply Connection

Check the input voltage, phase, and frequency of the power source that will be connected to this wire feeder. The acceptable level of input voltage is indicated in the section „Technical Specifications" and on the rating plate of the power source. Verify the connection of grounding wires from the power source to the input source.

## Controls and Operational Features

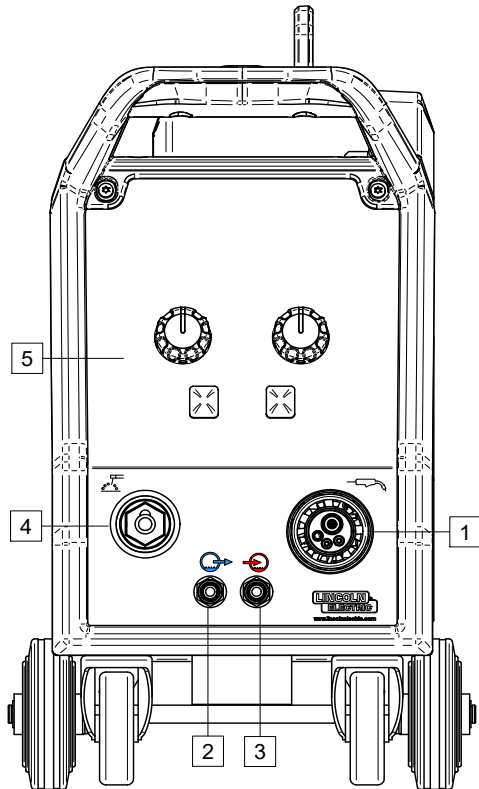

Figure 1

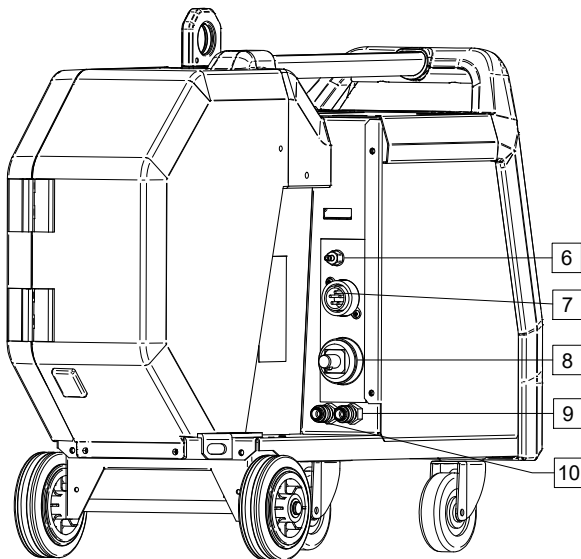







Figure 2

1. **EURO Socket:** For connecting a welding gun (for GMAW, FCAW process). 
2. **Quick Coupling Socket:** Coolant outlet (supplies cool coolant to the welding gun). 
3. **Quick Coupling Socket:** Coolant inlet (takes warm coolant from the welding gun). 





**! WARNING**

Maximum coolant pressure is 5 bar.

4. **Output Socket for SMAW and CAG welding:** For connecting welding cable with an electrode holder. 
5. **U22 User Interface:** See „User Interface” section.
6. **Gas Quick Coupling Socket:** For connecting a gas pipe. 

**! WARNING**

The welding machine supports all suitable shielding gases at a maximum pressure of 5,0 bar.

7. **Control Socket:** 5 pins socket for connecting a control cable. The CAN protocol is used for communication between the power source and wire feeder. 
8. **Current Socket:** For connecting a welding cable. 
9. **Quick Coupling Socket:** Coolant inlet (supplies cool coolant from cooler to the welding machine). 
10. **Quick Coupling Socket:** Coolant outlet (takes warm coolant from welding machine to cooler). 

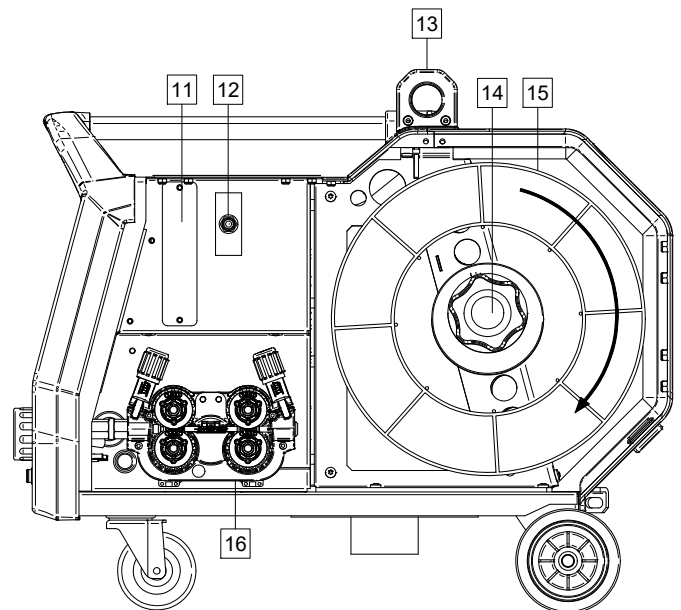

Figure 3

11. **Gas Flow Regulator Plug:** Gas Flow Regulator can be purchased separately. See "Accessories" section.
12. **Switch: Cold Inch / Gas Purge:** This switch allows wire feeding (wire test) and gas flow (gas test) without switching on the output voltage.
13. **Transport Holder:** For the feeder lifting and transporting using a crane.
14. **Wire Spool Holder:** For wire spool with maximum 16kg weight. Holder allows mounting plastic, steel and fiber spools on the 51mm spindle.



**! WARNING**

Be sure that wire spool case has to be completely closed during welding.

15. Spool with Wire: Not supplied as standard.

16. Wire Drive: 4-rolls wire drive.

**! WARNING**

The wire drive door and wire spool case have to be completely closed during welding.

**! WARNING**

Not use handle to move the machine during work.

## User Interface U22

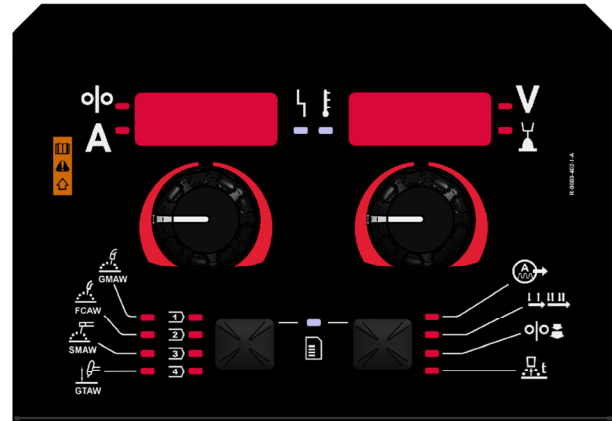

Figure 4

Detailed operation of Global User Interface can be found in the IM3197 user manual.

### Loading the Wire Spool

Spools of wire with a maximum weight of 16 kg can be used without an adapter. Holder allows mounting plastic, steel and fiber spools on the 51mm spindle.

It is possible to use other spools after using the appropriate adapter, which can be purchased separately (see "Accessories" chapter).

### Loading the Electrode Wire

- Turn the input power OFF.
- Open the spool wire case.
- Unscrew the locking nut of the sleeve [14].
- Load the spool wire on the sleeve so that the spool turns clockwise when the wire is feed into the wire feeder.
- Make sure that the spindle brake pin goes into the fitting hole on the spool.
- Screw in the locking nut of the sleeve.
- Open the wire drive door.
- Put on the wire roll with the correct groove corresponding to the wire diameter.
- Free the end of the wire and cut off the bent end making sure it has no burr.

**! WARNING**

Sharp end of the wire can hurt.

- Rotate the wire spool clockwise and thread the end of the wire into the wire feeder as far as the Euro Socket.
- Adjust force of pressure roll of the wire feeder properly.

## Adjustments of Brake Torque of Sleeve

To avoid spontaneous unrolling of the welding wire the sleeve is fitted with a brake.

Adjustment is carried by rotation of its screw M10, which is placed inside of the sleeve frame after unscrewing the brake locking nut.

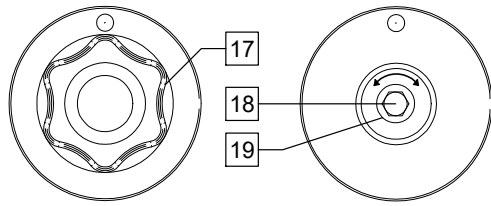

Figure 5

- 17. Locking Nut.
- 18. Adjusting Screw M10.
- 19. Pressing Spring.

Turning the M10 screw clockwise increases the spring tension and increase the brake torque

Turning the M10 screw anticlockwise decreases the spring tension and decrease the brake torque.

After finishing of adjustment, you should screw brake locking nut again.

## Adjusting Pressure Roll Force

The pressure arm controls the amount of force the drive rolls exert on the wire. Pressure force is adjusted by turning the adjustment nut clockwise to increase force, counterclockwise to decrease force. Proper adjustment of pressure arm gives the best welding performance.

### **WARNING**

If the roll pressure is too weak, the roll will slide on the wire. If the roll pressure is set too heavy the wire may be deformed, which cause feeding problems in the welding. The pressure force should be set properly. For this purpose decrease the pressure force slowly until the wire just begins to slide on the drive roll and then increase the force slightly by turning of the adjustment nut by one turn.

## Inserting Electrode Wire into Welding Torch

- Turn the welding machine off.
- Depending of welding process connect proper welding torch to the euro socket [1]. Rated parameters of the torch and welding machine should be matched.
- Depends on type of gun must be remove the nozzle from the gun and contact tip or protection cap and contact tip.
- Turn the welding machine on.
- Hold the Cold Inch/Gas Purge Switch [12] or use torch trigger until wire appear over threaded end of the gun.
- When the Cold Inch Switch [12] or torch trigger is released the spool of wire should not unwind.
- Adjust wire spool brake accordingly.
- Turn the welding machine off.
- Install a proper contact tip.
- Depending on the welding process and the type of the gun, install the nozzle (GMAW process) or protection cap (FCAW process).

### **WARNING**

Take precaution to keep eyes and hands away from the end of the gun while the wire is being come out of the threaded end.

## Changing Driving Rolls

### WARNING

Turn the input power off before installation or changing drive rolls.

Wire Feeders **LF 52** is equipped with drive roll V1.0/V1.2 for steel wire. For others wires and sizes it is required to install proper drive rolls kit (see "Accessories" chapter) and follow instruction:

- Turn the input power OFF.
- Unlock 4 rolls by turning 4 Quick-Change Carrier Gear [24].
- Release the pressure roll levers [25].
- Change the drive rolls [23] corresponding to the used wire.

### WARNING

Be sure that the gun liner and contact tip are also sized to match the selected wire size.

### WARNING

For wires with the diameter larger than 1.6mm, the following parts are to be changed:

- The guide tube of the feeding console [21] and [22].
- The guide tube of the Euro Socket [20].
- Lock 4 new rolls by turning 4 Quick-Change Carrier Gear [24].
- Insert the wire through the guide tube, over the roller and through the guide tube of Euro Socket into liner of gun. The wire can be pushed into the liner manually for a few centimeters, and should feed easily and without any force.
- Lock the pressure roll levers [25].

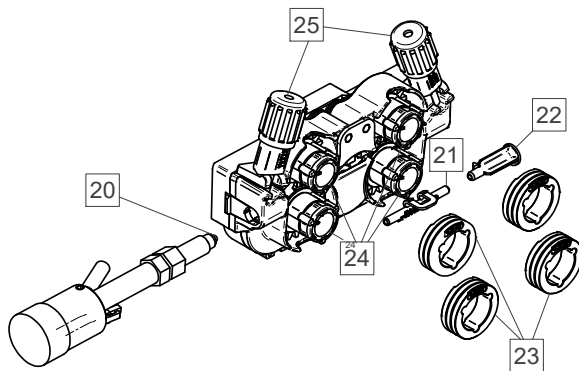

Figure 6

## Gas Connection

### WARNING



- CYLINDER may explode if damaged.
- Always fix the gas cylinder securely in an upright position, against a cylinder wall rack or purpose-made cylinder cart.
- Keep cylinder away from areas where it may be damaged, heated, or electrical circuits to prevent possible explosion or fire.
- Keep cylinder away from welding or other live electrical circuits.
- Never lift welder with cylinder attached.
- Never allow welding electrode to touch cylinder.
- Build up of shielding gas may harm health or kill. Use in a well-ventilated area to avoid gas accumulation.
- Close the gas cylinder valves thoroughly when not in use to avoid leaks.

### WARNING

The welding machine supports all suitable shielding gases at a maximum pressure of 5,0 bar.

### WARNING

Before use, make sure that the gas cylinder contains gas suitable for the intended purpose.

- Turn off input power at the welding power source.
- Install a proper gas flow regulator to the gas cylinder.
- Connect the gas hose to the regulator using the hose clamp.
- The other end of the gas hose connect to the gas connector on the power source rear panel or directly to the quick connector located on the rear panel of the wire feeder [6]. More details you will find in power source instruction manual.
- Connect by dedicated interconnection cable (see „Accessories“ chapter) wire feeder and power source.
- Turn on input power at the welding power source.
- Open the gas cylinder valve.
- Adjust the shielding gas flow of the gas regulator.
- Check gas flow with Gas Purge Switch [12].

### WARNING

To weld GMAW process with CO<sub>2</sub> shielding gas, CO<sub>2</sub> gas heater should be used.

## Transport and Lifting



### **! WARNING**

Falling equipment can cause injury and damage to unit.

During transporting and lifting with a crane, adhere to the following rules:

- For lifting a suitable lifting equipment capacity.
- Dedicated handle [13] can be used to lifting and transporting using a crane only. This solution enables welding while lifting the feeder.

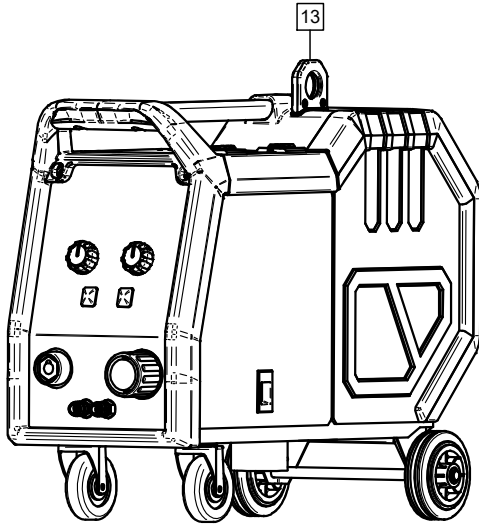

Figure 7

## Maintenance

### **! WARNING**

For any repair operations, modifications or maintenances, it is recommended to contact the nearest Technical Service Center or Lincoln Electric. Repairs and modifications performed by unauthorized service or personnel will cause the lost of the manufacturer's warranty.

Any noticeable damage should be reported immediately and repaired.

### **Routine maintenance (everyday)**

- Check condition of insulation and connections of the work leads and insulation of power lead. If any insulation damage exists replace the lead immediately.
- Remove the spatters from the welding gun nozzle. Spatters could interfere with the shielding gas flow to the arc.
- Check the welding gun condition: replace it, if necessary.
- Check condition and operation of the cooling fan. Keep clean its airflow slots.

### **Periodic maintenance (every 200 working hours but at least once a year)**

Perform the routine maintenance and, in addition:

- Keep the machine clean. Using a dry (and low pressure) airflow, remove the dust from the external case and from the cabinet inside.
- If it is required, clean and tighten all weld terminals.

The frequency of the maintenance operations may vary in accordance with the working environment where the machine is placed.

### **! WARNING**

Do not touch electrically live parts.

### **! WARNING**

Before the case of machine will be removed, the machine has to be turned off and the power lead has to be disconnected from mains socket.

### **! WARNING**

Mains supply network must be disconnected from the machine before each maintenance and service. After each repair, perform proper tests to ensure safety.

## **Customer Assistance Policy**

The business of The Lincoln Electric Company is manufacturing and selling high quality welding equipment, consumables, and cutting equipment. Our challenge is to meet the needs of our customers and to exceed their expectations. On occasion, purchasers may ask Lincoln Electric for advice or information about their use of our products. We respond to our customers based on the best information in our possession at that time. Lincoln Electric is not in a position to warrant or guarantee such advice, and assumes no liability, with respect to such information or advice. We expressly disclaim any warranty of any kind, including any warranty of fitness for any customer's particular purpose, with respect to such information or advice. As a matter of practical consideration, we also cannot assume any responsibility for updating or correcting any such information or advice once it has been given, nor does the provision of information or advice create, expand or alter any warranty with respect to the sale of our products.

Lincoln Electric is a responsive manufacturer, but the selection and use of specific products sold by Lincoln Electric is solely within the control of, and remains the sole responsibility of the customer. Many variables beyond the control of Lincoln Electric affect the results obtained in applying these types of fabrication methods and service requirements.

Subject to Change – This information is accurate to the best of our knowledge at the time of printing. Please refer to [www.lincolnelectric.com](http://www.lincolnelectric.com) for any updated information.

## Error

Table 1 shows list of basic errors that can appear. To get full list of error codes, please contact with authorize Lincoln Electric service.

**Table 1 Error codes**

Error code	Symptoms	Cause	Recommended Course of Action
6	Power source is not connected.	The User Interface cannot seem to communicate with the Power Source.	<ul style="list-style-type: none"> <li>Check cable connections between the power source and the user interface.</li> </ul>
36	The machine has shut down because it has overheated.	System detected a temperature level beyond the normal system operating limit.	<ul style="list-style-type: none"> <li>Be sure process does not exceed duty cycle limit of the machine.</li> <li>Check the setup for proper air flow around and through the system.</li> <li>Check that the system has been properly maintained, including removal of accumulated dust and dirt from the intake and outlet louvers.</li> <li>When the machine has cooled down to a safe level, the interface signals this by flashing two LEDs next to Button or start welding operation by the torch trigger.</li> </ul> 
81	Motor overload, long term.	The wire drive motor has overheated. Check that the electrode slides easily through the gun and cable.	<ul style="list-style-type: none"> <li>Remove tight bends from the gun and cable.</li> <li>Check that the spindle brake is not too tight.</li> <li>Verify the adequacy of the electrode to the welding process.</li> <li>Verify a high quality electrode is being used.</li> <li>Check drive rolls alignment and gears.</li> <li>Wait for the error to reset and the motor to cool (approximately 1 minute).</li> </ul>
92	No coolant flow	There is no coolant flow in the cooler after 3 seconds of welding.	<ul style="list-style-type: none"> <li>Make sure there is enough coolant in the tank and that auxiliary power is supplied.</li> <li>Make sure the pump is working. When the trigger is pulled the pump should run.</li> </ul>

### **WARNING**

If for any reason you do not understand the test procedures or are unable to perform the tests/repairs safely, contact your Local Lincoln Authorized Field Service Facility for technical troubleshooting assistance before you proceed.

# WEEE

07/06



Do not dispose of electrical equipment together with normal waste!  
In observance of European Directive 2012/19/EC on Waste Electrical and Electronic Equipment (WEEE) and its implementation in accordance with national law, electrical equipment that has reached the end of its life must be collected separately and returned to an environmentally compatible recycling facility. As the owner of the equipment, you should get information on approved collection systems from our local representative.

By applying this European Directive you will protect the environment and human health!

## Spare Parts

12/05

### Part List reading instructions

- Do not use this part list for a machine if its code number is not listed. Contact the Lincoln Electric Service Department for any code number not listed.
- Use the illustration of assembly page and the table below to determine where the part is located for your particular code machine.
- Use only the parts marked "X" in the column under the heading number called for in the assembly page (# indicate a change in this printing).

First, read the Part List reading instructions above, then refer to the "Spare Part" manual supplied with the machine, that contains a picture-descriptive part number cross-reference.

## Authorized Service Shops Location

09/16

- The purchaser must contact a Lincoln Authorized Service Facility (LASF) about any defect claimed under Lincoln's warranty period.
- Contact your local Lincoln Sales Representative for assistance in locating a LASF or go to [www.lincolnelectric.com/en-gb/Support/Locator](http://www.lincolnelectric.com/en-gb/Support/Locator).

## Electrical Schematic

Refer to the "Spare Part" manual supplied with the machine.

## Accessories

OPTIONS & ACCESSORIES	
K14204-1	WIRE FEEDER DRUM QUICK CONNECTOR
K14175-1	GAS FLOW METER KIT (POWERTEC-I)
E/H-400A-70-5M	ELECTRODE HOLDER 400A/70MM <sup>2</sup> - 5M
K10158-1	ADAPTER FOR SPOOL TYPE B300
K10158	ADAPTER FOR SPOOL TYPE B300
R-1019-125-1/08R	ADAPTER FOR SPOOL S200
FL060583010	FLAIR 600 GOUGING TORCH WITH MOUNTED LEAD 2,5M
COMPATIBLE POWER SOURCES	
K14258-1	SPEEDTEC <sup>®</sup> 400SP
K14259-1	SPEEDTEC <sup>®</sup> 500SP
K14183-1	POWERTEC <sup>®</sup> i350S
K14184-1	POWERTEC <sup>®</sup> i420S
K14185-1	POWERTEC <sup>®</sup> i500S
K4283-1	FLEXTEC <sup>®</sup> 350x CONSTRUCTION
K4284-1	FLEXTEC <sup>®</sup> 350x STANDARD
K3607-2	FLEXTEC <sup>®</sup> 500x
MIG/MAG WELDING GUNS	
W10429-36-3M	LGS2 360 G-3.0M, AIR -COOLED MIG WELDING GUN
W10429-36-4M	LGS2 360 G-4.0M, AIR-COOLED MIG WELDING GUN
W10429-36-5M	LGS2 360 G-5.0M, AIR -COOLED MIG WELDING GUN
W10429-505-3M	LGS2 505W 3.0M, WATER COOLED-MIG WELDING GUN
W10429-505-4M	LGS2 505W 4.0M, WATER COOLED-MIG WELDING GUN
W10429-505-5M	LGS2 505W 5.0M, WATER COOLED-MIG WELDING GUN
PROMIG MAGNUM	
W000345072-2	PROMIG MAGNUM 370 3M
W000345073-2	PROMIG MAGNUM 370 4.5M
W000345069-2	PROMIG MAGNUM 400W 3M
W000345070-2	PROMIG MAGNUM 400W 4.5M
W000345075-2	PROMIG MAGNUM 500W 3M
W000345076-2	PROMIG MAGNUM 500W 4.5M
ROLL KIT FOR SOLID WIRES	
KP14150-V06/08	ROLL KIT 0.6/0.8VT FI37 4 SZT. GREEN/NIEBIESKI
KP14150-V08/10	ROLL KIT 0.8/1.0VT FI37 4 SZT. BLUE/RED
KP14150-V10/12	ROLL KIT 1.0/1.2VT FI37 4 SZT. RED/ORANGE
KP14150-V12/16	ROLL KIT 1.2/1.6VT FI37 4 SZT. ORANGE/YELLOW
KP14150-V16/24	ROLL KIT 1.6/2.4VT FI37 4 SZT. YELLOW/GREY
KP14150-V09/11	ROLL KIT 0.9/1.1VT FI37 4 SZT.
KP14150-V14/20	ROLL KIT 1.4/2.0VT FI37 4 SZT.
ROLL KIT FOR ALUMINIUM WIRES	
KP14150-U06/08A	ROLL KIT 0.6/0.8AT FI37 4 SZT. GREEN/BLUE
KP14150-U08/10A	ROLL KIT 0.8/1.0AT FI37 4 SZT. BLUE/RED
KP14150-U10/12A	ROLL KIT 1.0/1.2AT FI37 4 SZT. RED/ORANGE
KP14150-U12/16A	ROLL KIT 1.2/1.6AT FI37 4 SZT. ORANGE/YELLOW
KP14150-U16/24A	ROLL KIT 1.6/2.4AT FI37 4 SZT. YELLOW/GREY



<b>ROLL KIT FOR CORE WIRES</b>	
KP14150-V12/16R	ROLL KIT 1.2/1.6RT FI37 4 SZT. ORANGE/YELLOW
KP14150-V14/20R	ROLL KIT 1.4/2.0RT FI37 4 SZT.
KP14150-V16/24R	ROLL KIT 1.6/2.4RT FI37 4 SZT. YELLOW/GREY
KP14150-V09/11R	ROLL KIT 0.9/1.1RT FI37 4 SZT.
KP14150-V10/12R	ROLL KIT 1.0/1.2RT FI37 4 SZT. -ORANGE
<b>WIRE GUIDES</b>	
0744-000-318R	WIRE GUIDE SET BLUE, Ø0,6-1,6
0744-000-319R	WIRE GUIDE SET RED, Ø1,8-2,8
D-1829-066-4R	EURO WIRE GUIDE; Ø0,6-1,6
D-1829-066-5R	EURO WIRE GUIDE; Ø1,8-2,8
<b>INTERCONNECION CABLES</b>	
K14198-PG	CABLE PACK 5PIN G 70MM2 1 M
K14198-PG-3M	CABLE PACK 5PIN G 70MM <sup>2</sup> 3M
K14198-PG-5M	CABLE PACK 5PIN G 70MM2 5M
K14198-PG-10M	CABLE PACK 5PIN G 70MM2 10M
K14198-PG-15M	CABLE PACK 5PIN G 95MM2 15M
K14198-PG-20M	CABLE PACK 5PIN G 95MM2 20M
K14198-PG-25M	CABLE PACK 5PIN G 95MM2 25M
K14198-PG-30M	CABLE PACK 5PIN G 95MM2 30M
K14199-PGW	CABLE PACK 5PIN W 95MM2 1 M
K14199-PGW-3M	CABLE PACK 5PIN W 95MM <sup>2</sup> 3M
K14199-PGW-5M	CABLE PACK 5PIN W 95MM2 5M
K14199-PGW-10M	CABLE PACK 5PIN W 95MM2 10M
K14199-PGW-15M	CABLE PACK 5PIN W 95MM2 15M
K14199-PGW-20M	CABLE PACK 5PIN W 95MM2 20M
K14199-PGW-25M	CABLE PACK 5PIN W 95MM2 25M
K14199-PGW-30M	CABLE PACK 5PIN W 95MM2 30M

# Connection Diagram

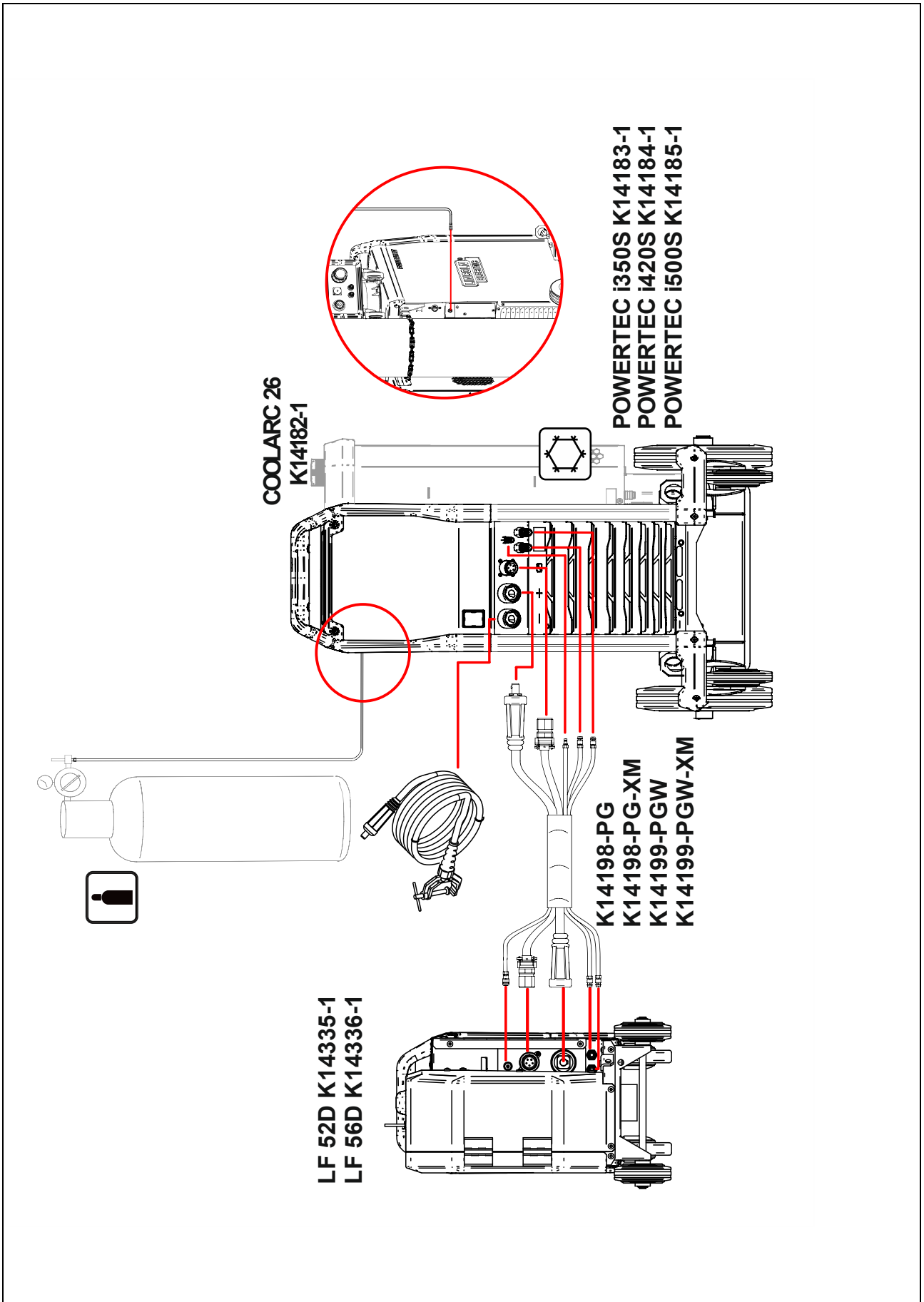

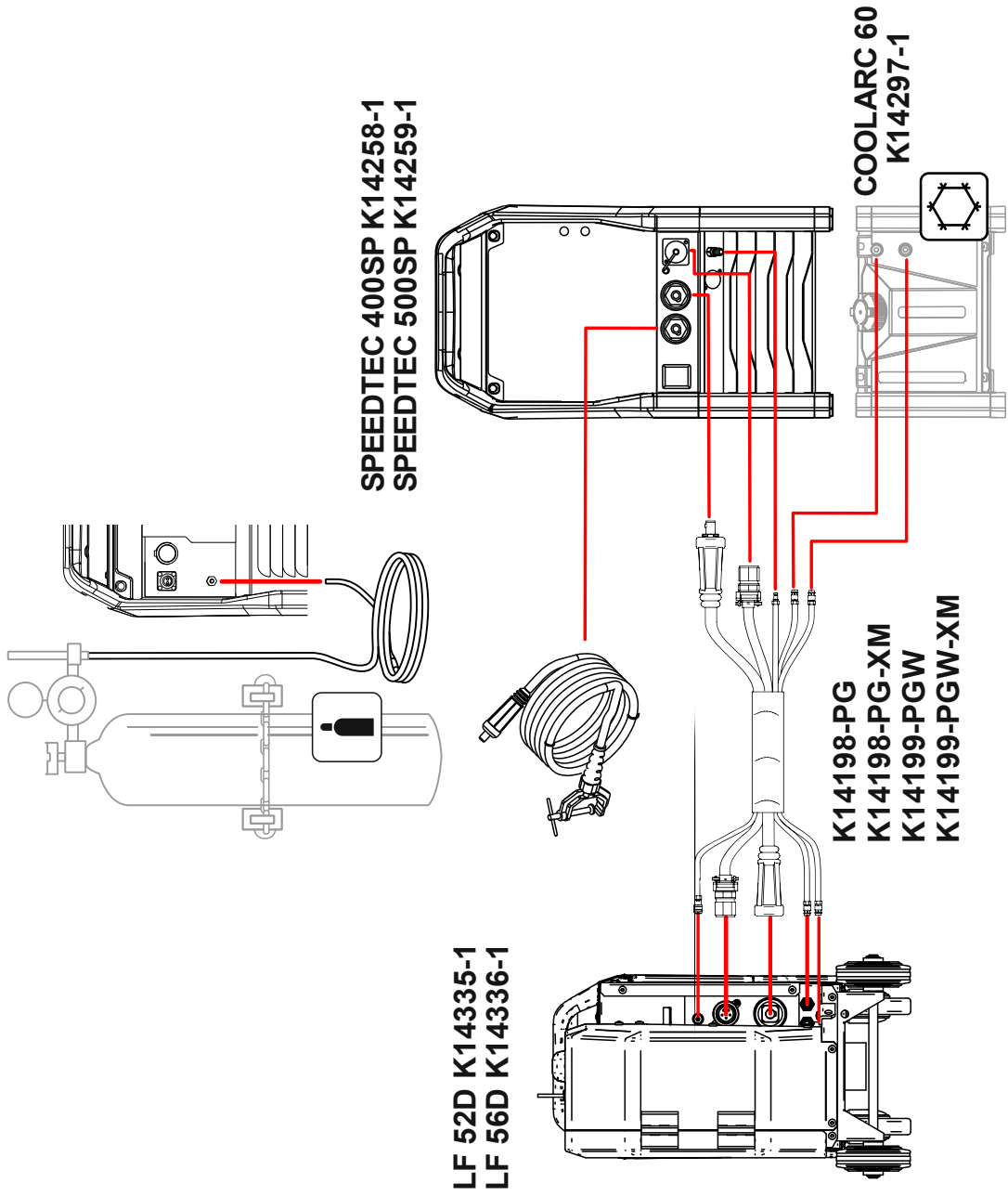

# Dimension Diagram

