

**M12149, 83-382, P10015, PCS21, YA2225**

# M12149, YA2225, 83-382, P10015

Item	Stock #	Customer #	Description
1	412-754-666	260457	Support
2	411-118-026	260460	Left Side Panel
3	412-755-666	260459	Center Divider
4	246-519-666	B7053370	Contactora
5		251145	Rectifier
6	239-298-666	B7009380	Terminal Board
8	880-593-000	251148	Control Circuit Board
10	238-707-666	251150	Input Cable
11	246-532-666	B7005380	Pressure Switch
12	246-530-666	251036	Solenoid
13	254-006-666	B7006380	Regulator
14	251-030-666	B7014380	Gauge
15	216-110-666	260453	Fan Motor
16	213-043-666	260468	Capacitor
18		251153	Elbow Fitting
19	215-036-666	B7029380	Resistor
20	253-341-666	B7004380	Fitting
23	260-001-666	251155	Capacitor
24	246-531-666	251156	Thermostat
26	312-515-666	250975	Handle
27		260497	Control Panel
28	411-110-026	260461	Right Side Panel

Item	Stock #	Customer #	Description
29	880-579-666	260464	Transformer
30	411-116-016	260500	Base
31	312-516-666	260470	Front Panel Frame
32	238-708-666	251159	Ground Cable
33		251160	Torch Cable
34	312-518-666	B7037380	Torch Handle & Trigger
35	334-651-000	M15810,YA22259,83-662	Nozzle Holder
36	334-653-000	M15814,YA22252,83-666	Standard Nozzle, 1mm
	334-593-000	M15805,YA22254,83-631	Long Nozzle, 1mm (3)
37	334-589-000	M15803,M15852,YA22257,83-629	Diffuser (2)
38	334-592-000	M15802,YA22251,83-628	Standard Electrode (5)
	334-594-000	M15807,YA22253,83-633	Long Electrode (2)
39	334-629-000	B7039380	Torch Head
<b>40</b>	<b>334-636-000</b>	<b>M15822,250748,83-675</b>	<b>Torch, 13FT</b>
41	414-020-666	B7018380	Strain Relief
42	246-537-666	B7069370	Switch
43		247541	Warning Label
44		247542	Warning Label
45		247505	Label
46		247509	Warning Label
47	411-119-026	260466	Top Panel
48	512-265-666	260467	Rubber Mat

8/17/2006

Model	Primary Input	Input Plug	Duty Cycle at Rated Output
M12149	120 Vac	15A	20%

Rated Output	Voltage Settings	Agency Listing	Max Cutting Thickness
25 amps	1	CSA	3/16"

16 & 23 - Capacitors

M12149, 83-382, P10015, YA2225

Terminal Block

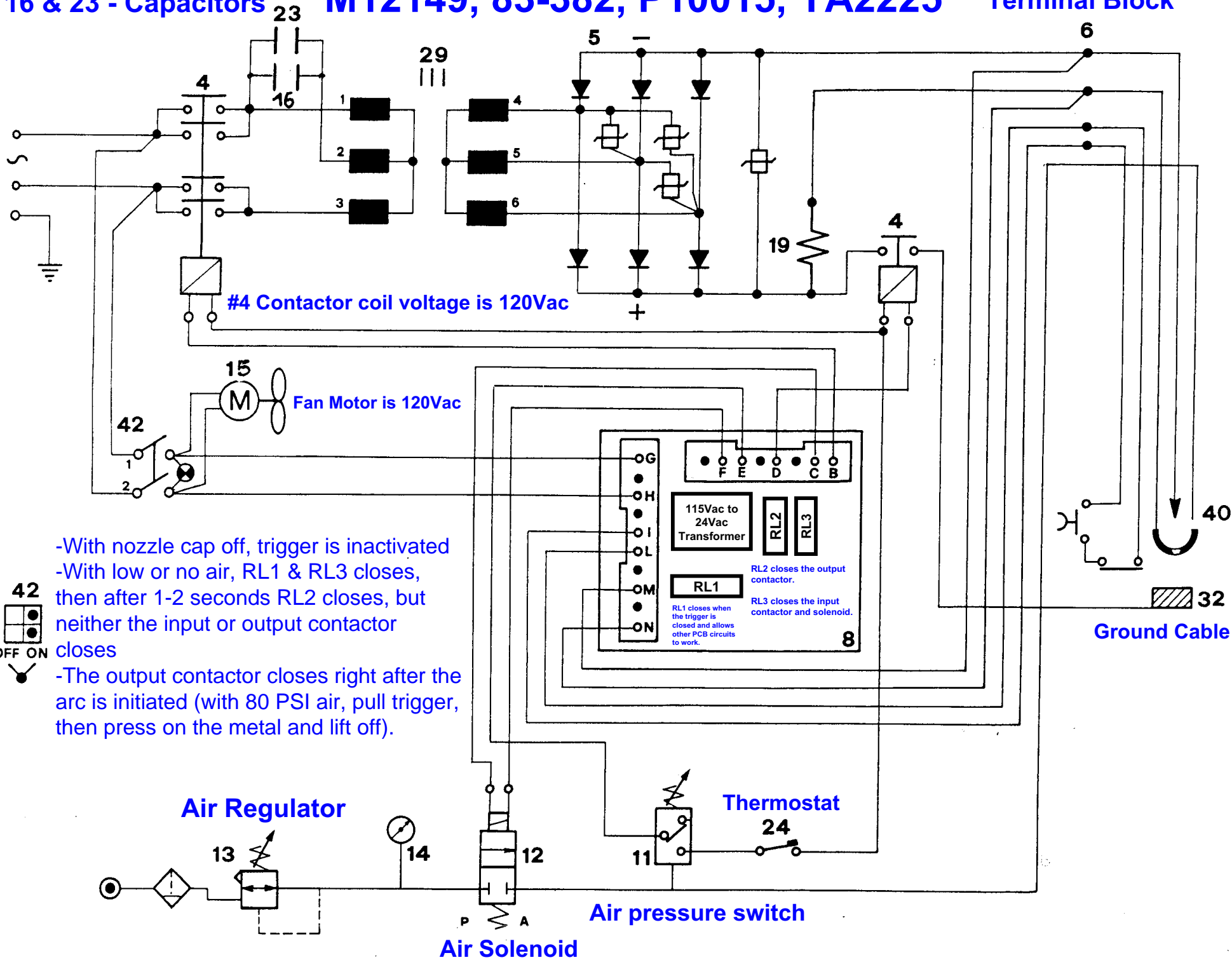

- With nozzle cap off, trigger is inactivated
- With low or no air, RL1 & RL3 closes, then after 1-2 seconds RL2 closes, but neither the input or output contactor closes
- The output contactor closes right after the arc is initiated (with 80 PSI air, pull trigger, then press on the metal and lift off).