

INSTALLATION

FINELINE

SAFETY INSTRUCTIONS FOR OPERATING AND MAINTENANCE

MACHINE No P04152000NG - P04152001NG - P04152010NG - P04152011NG



ISSUE : EN
REVISION : G
DATE : 09 - 2024

Instruction manual

REF : 8695 4498

Original instructions

LINCOLN[®]
ELECTRIC

Thank you very much for the trust you have shown by choosing this piece of equipment. It will give you trouble-free service if it is used and maintained as recommended.

Its design, component specifications and manufacturing are in accordance with applicable European directives.

Please refer to the CE declaration enclosed to identify the directives applicable to it.

The manufacturer shall not be liable for any combination of parts not recommended by it.

For your safety, please follow the non-limitative list of recommendations and obligations, a large part of which are included in the Labour Code.

Please inform your supplier if you find any error in this instruction manual.

Table of contents

A - IDENTIFICATION.....	1
1 - Fineline machine.....	1
2 - THD tool holder.....	2
3 - Fineline power source + gas controller + arc strike controller + LC300M torch.....	2
4 - Human Machine Interface (HMI) for integrated installation on machine.....	2
5 - Magnetic torch impact safety system.....	2
6 - (Optional) Fineline APC advanced process controller.....	2
B - SAFETY INSTRUCTIONS.....	3
1 - Particular safety instructions.....	3
2 - User safety in respect of electrical hazards.....	4
3 - Thermal hazards.....	5
4 - Electromagnetic pollution.....	5
5 - Gas pollution.....	5
6 - Liquid pollution.....	6
7 - Sound pollution.....	6
8 - Measurement of airborne noise.....	6
9 - Ground connection principle.....	7
C - DESCRIPTION	8
1 - Possibilities of the Fineline machine.....	8
2 - Installation integrated in Lincoln Electric machine.....	8
3 - Gas connection unit (AGC: BK300350).....	11
4 - Torch connection unit (ASC: K4901-1).....	11
5 - Fineline APC advanced process controller: BK300370).....	11
6 - THD (PO) tool holder and magnetic torch impact safety system (CT).....	12
7 - Torch connector (ET).....	13
8 - Torch (NT).....	13
9 - Power source (G).....	14
10 - Refrigeration unit (G).....	14
11 - (Optional) Fineline APC advanced process controller.....	14
12 - (Optional) EV coolant shutoff solenoid valve.....	14
D - ASSEMBLY AND INSTALLATION	15
1 - Installation conditions.....	15
1.1 Fluid supply.....	15
1.2 Electricity supply.....	16
1.3 Operating temperature.....	17
2 - Destruction and scrapping.....	17
3 - Unpacking and handling.....	18
4 - Installation.....	19
4.1 Fluid connections.....	19
4.2 Electrical connections.....	20
4.3 Assembly.....	20
4.4 Connections.....	20
5 - Installation of the tool holder THD.....	20
6 - Installation of the torch connection unit (ASC).....	21
7 - Installation of the torch connector and torch.....	21

8 - Installation of the gas connection unit (AGC)-----	21
9 - Installation of the power source and refrigerant unit-----	21
10 - Installation and connections of optional APC-----	21
E - OPERATING MANUAL	22
1 - Operator controls -----	22
1.1 HMI controls-----	22
1.2 Torch movement controls -----	22
2 - Adjustment -----	22
2.1 Adjustment of process parameters -----	22
3 - Change in gas supply -----	22
4 - Change in consumables-----	22
5 - Cycles-----	23
F - MAINTENANCE.....	24
1 - Care-----	24
2 - Troubleshooting-----	25
2.1 Electrical problems -----	25
2.2 Explanation of alarms: overall process fault-----	25
2.3 Explanation of alarms: Fineline plasma-----	26
2.4 Fineline power source faults -----	27
2.5 Gas controller faults-----	27
2.6 Optional APC faults-----	27
2.7 Other faults-----	27
3 - Maintenance of the tool holder THD-----	28
4 - Maintenance of the Fineline power source-----	28
5 - Maintenance of the gas control unit-----	28
6 - Maintenance of the strike controller-----	28
7 - Maintenance of the torch LC300M-----	28
8 - Maintenance of the optional APC installation -----	28
9 - Spare parts-----	29
9.1. Main parts-----	30
9.2 Bundle maintenance -----	32
9.3 Selection of consumables-----	36
9.4 Consumables for cutting with lubrication (optional APC)-----	40
9.5 HPCIII process control assembly (main cabinet)-----	44
PERSONAL NOTES	46

INFORMATION

This technical literature is intended for the following machines or products:

- P04152000NG → **Fineline 170** installation for **Optitome² HPC III**
- P04152001NG → **Fineline 300** installation for **Optitome² HPC III**
- P04152010NG → **Fineline 170** installation for **Oxytome/Plasmatome HPC III**
- P04152011NG → **Fineline 300** installation for **Oxytome/Plasmatome HPC III**
- AS-CM-OPT2D1530FL1 → **Optitome² HPC III 1530 Fineline 170**
- AS-CM-OPT2D1530FL3 → **Optitome² HPC III 1530 Fineline 300**
- AS-CM-LCC1530FL170 → **Linc-Cut C HD Fineline 170 1500x3000**
- AS-CM-LCC1530FL300 → **Linc-Cut C HD Fineline 300 1500x3000**
- P04151010NG → Optional mixer for **Fineline**
- P04152090NG → Optional local console coolant shutoff solenoid valve
- P04152091NG → Optional fixed console coolant shutoff solenoid valve
- P04151020NG → Optional APC advanced process controller for **Fineline**



This manual and the product with which it is associated refer to the applicable standards in force.



Please read this document carefully before you install, use or maintain the machine. Keep this document in a safe place for future reference. This document must follow the machine described if there is a change in ownership of the machine and accompany it up to demolition.



Display and pressure gauge:

Measurement instruments or displays of voltage, intensity, speed, accuracy etc. are to be considered as indicators, whether they are analogue or digital.



For operating instructions, adjustments, troubleshooting and spare parts, please refer to the special instructions for safe operating and maintenance.

Instructions no	Description
BK8053-000111	Fineline 170 HD plasma system
BK8053-000107	Fineline 300 HD plasma system
BK8053-000117	Fineline APC optional advanced process controller
86954568 86954569	THD tool holder THDi C tool holder
86954606	Magnetic torch impact safety system
86954995	HPC DIGITAL PROCESS III

REVISIONS

REVISION : B DATE : 03/22

DESCRIPTION	PAGE
Created in English	

REVISION : C DATE : 06/22

DESCRIPTION	PAGE
Spare parts	36 - 37 - 38 - 39

REVISION : D DATE : 03/23

DESCRIPTION	PAGE
Fineline APC advanced process controller added	

REVISION : E DATE : 10/23

DESCRIPTION	PAGE
Linc-Cut C HD added	

























REVISION : F DATE : 02/24

DESCRIPTION	PAGE
Imperial measurements added Update of MAGNUM PRO	

REVISION : G DATE : 09/24

DESCRIPTION	PAGE
BK1111-200207 => BK1111-200216	36 - 37 - 38 - 39 - 41

MEANING OF SYMBOLS

	Reading the manual/instructions is mandatory.		Indicates a hazard.
	Mandatory use of safety shoes.		Warning of an electricity risk or hazard.
	Mandatory use of hearing protection.		Warning of a risk or hazard due to an obstacle on the floor.
	Mandatory use of a safety helmet.		Warning of a risk or hazard of falling with a level change.
	Mandatory use of safety gloves.		Warning of a risk or hazard due to suspended loads.
	Mandatory use of safety glasses.		Warning of a risk or hazard due to a hot surface.
	Mandatory use of a safety visor.		Warning of a risk or hazard due to moving mechanical parts.
	Mandatory use of safety clothing.		Warning of a risk or hazard due to a closing movement of mechanical parts of a machine.
	Make sure you clean the working zone.		Warning of a risk or hazard due to laser radiation.
	Mandatory use of breathing protection.		Warning of a risk or hazard due to an obstacle at a height.
	Visual inspection required.		Warning of a risk or hazard due to the presence of a pointed part.
	Indicates a lubrication operation.		Wearers of pacemakers may not be admitted in the designated area.
	Requires maintenance action.		

A - IDENTIFICATION

1 - Fineline machine



Please note the number of your machine in the box below. This information will be required if you contact our after-sales service department. Other locations are available for indicating the part numbers of each component in the system.



Object	Type	Number	Year of manufacture
Fineline (G) power source			
Fineline (GC) gas controller			
Fineline (ASC) Arc strike controller			
Fineline APC advanced process controller			
THD (P) tool holder			
LC300M (T) torch			

Fineline Machine	
Reference	Description
T	LC300M torch
ET	Torch connector + torch bundle
G	Fineline power source
GC	Fineline gas controller
ASC	Fineline arc strike controller
APC	Optional Fineline APC advanced process controller
P	THD or THDi C tool holder
CT	Magnetic torch impact safety system

2 - THD tool holder



Please refer to the document:

- 86954568: THD tool holder
- 86954569: THDi C tool holder

3 - Fineline power source + gas controller + arc strike controller + LC300M torch



Please refer to the document:

- BK5043-000111: FINELINE 170
- BK5043-000107: FINELINE 300

4 - Human Machine Interface (HMI) for integrated installation on machine



Please refer to the document:

- 86954995: HPC DIGITAL PROCESS III

5 - Magnetic torch impact safety system



Please refer to the document:

- 86954606: Magnetic torch impact safety system

6 - (Optional) Fineline APC advanced process controller



Please refer to the document:

- BK8053-000117: Fineline APC advanced process controller

B - SAFETY INSTRUCTIONS



In spite of all the measures applied, invisible residual risks may still remain. Residual risks can be reduced if the safety instructions are observed, the machine is used as recommended and general service instructions are followed

1 - Particular safety instructions



For general safety instructions, please refer to the specific manual supplied with this equipment, no 86957050.



During operation, and also during adjustment, the use of Personal Protective Equipment (PPE) is **mandatory**. (see document BK8053-000111 (Fineline 170) or BK8053-000107 (Fineline 300) for more details).



The standard provides for the use of tinted glasses with 12 rating for Fineline 170 and 13 rating for Fineline 300. It is mandatory to put in place a guard while cutting. If sufficient reduction is impossible for technical reasons (e.g. when the operator is monitoring the process), all workers who remain close to the machine must wear eye protection equipment and appropriate clothing.



“No climbing on the structure of the machine other than on platforms or gangways designed for that purpose. To access equipment at heights, the user must use accessing means in accordance with the regulations, such as a safe mobile gangway, an aerial lift etc.”.



Before using the machine, make sure that all the guards are in place. All guard covers must be screwed in. Only authorised personnel may access electrical cabinets, which must have locking systems.



The machine may only be operated by a single operator trained in safe use.



Before use, the operator must make sure that there is no risk of collision with personnel.



Clean the working area from time to time.



This machine may only be moved by its designer, namely **Lincoln Electric**.



Never modify the installation. The installation is **not** designed for anchoring lifting equipment.

2 - User safety in respect of electrical hazards



Machine maintenance must be carried out **with all the energy supplies switched off**. The disconnection and padlocking of all energy sources is **mandatory**.



Before starting any work on the machine, make sure that the power source is switched off. The emergency stop does not shut down the power source supply.

Plasma arc cutting calls for fairly high output voltages in open circuits in the equipment. That is why particular precautions need to be taken in respect of the power supplies of the equipment.



The power and earth connections must be inspected from time to time

Please note that the power supplies of **Fineline** power sources and the machine must include primary protection devices, namely S-type combined switch and circuit breakers, or those that trip when a fault is present. Emergency stop buttons must be fitted in the main shutdown circuit of the whole machine, and be placed on the machine that receives the cutting system, in order to disable it from the operator station and from one or more points on the machine.

Disconnecting the control cabinet does not switch off the power source supply.



The emergency stop and safety lines must be interlocked and tested in accordance with the electricity diagram of the machine.



Voltage above 100 V is present in the power source when it is in service.

3 - Thermal hazards



It is absolutely necessary to be protected from the risk of burns (direct contact).

Plasma arc cutting generates a large quantity of heat.
Both the torch and the cut material present risks of burns.



It is absolutely necessary to be protected from splashes of molten metal (indirect contact).

Metal splatter at high temperatures may be generated while cutting.

4 - Electromagnetic pollution



It is absolutely necessary to protect your eyes from arc radiation.



The plasma process creates electrical and magnetic fields that may interfere with some cardiac pacemakers.
That is why people fitted with cardiac pacemakers, defibrillators or other vital-assistance medical devices must stay at a distance from the machine.
Where necessary, wearers of such devices must seek medical advice before entering the area around the machine.

The plasma arc, like all electric arcs, is a source of high-intensity radiation; the radiation emitted in the ultraviolet spectrum may damage the eyes and skin. The operator must wear filtering glasses in order to protect the eyes from fatigue.

5 - Gas pollution



Operators must absolutely be protected from the fumes produced during cutting.

Plasma cutting leads to the discharge of fumes (vapour and metal oxides). To control the exposure of the operator to these pollutant gases, the cutting job must be ventilated. The installation is designed to operate with an appropriate down-draft table (please enquire for rating). Regularly check the effectiveness of the extraction.

Under the standard, the speed required at the table is 1.15 m/s per torch.



The machine must absolutely undergo regular preventive maintenance.

The machine may sustain damage (pierced hose, leaky valve). In that case, the discharge of gas would not be controlled. All hoses and fittings must be inspected every month.

6 - Liquid pollution

Plasma arc cutting generates a large quantity of heat. The machine needs to be cooled. As a result, coolant is required for proper working.

Refer to the maintenance instructions of the cooler unit (included in the instructions of **Fineline**). The coolant used must be that stated in the instructions.



Please refer to the document:

- BK5043-000111: FINELINE 170
- BK5043-000107: FINELINE 300

7 - Sound pollution



The hearing of operators must absolutely be protected from the noise produced during cutting.

The noise generated by plasma arc cutting varies depending on the cutting conditions. Note that the laws and regulations allow 80 dB (A) noise for 8 hours of exposure. In fact, the time during which plasma cutting is used is generally shorter.

8 - Measurement of airborne noise

For airborne noise measurements, please refer to the specific manual supplied with the equipment.



Please refer to the document:

- BK5043-000111: FINELINE 170
- BK5043-000107: FINELINE 300



The use of hearing protection is required with a noise level above 80 dB, for the operator and for persons located nearby.



The noise generated by the process could drown out external sound warnings.

9 - Ground connection principle



To avoid problems with the Fineline machine, it is absolutely necessary for all the metal parts within the reach of the operator to be connected to the earth.

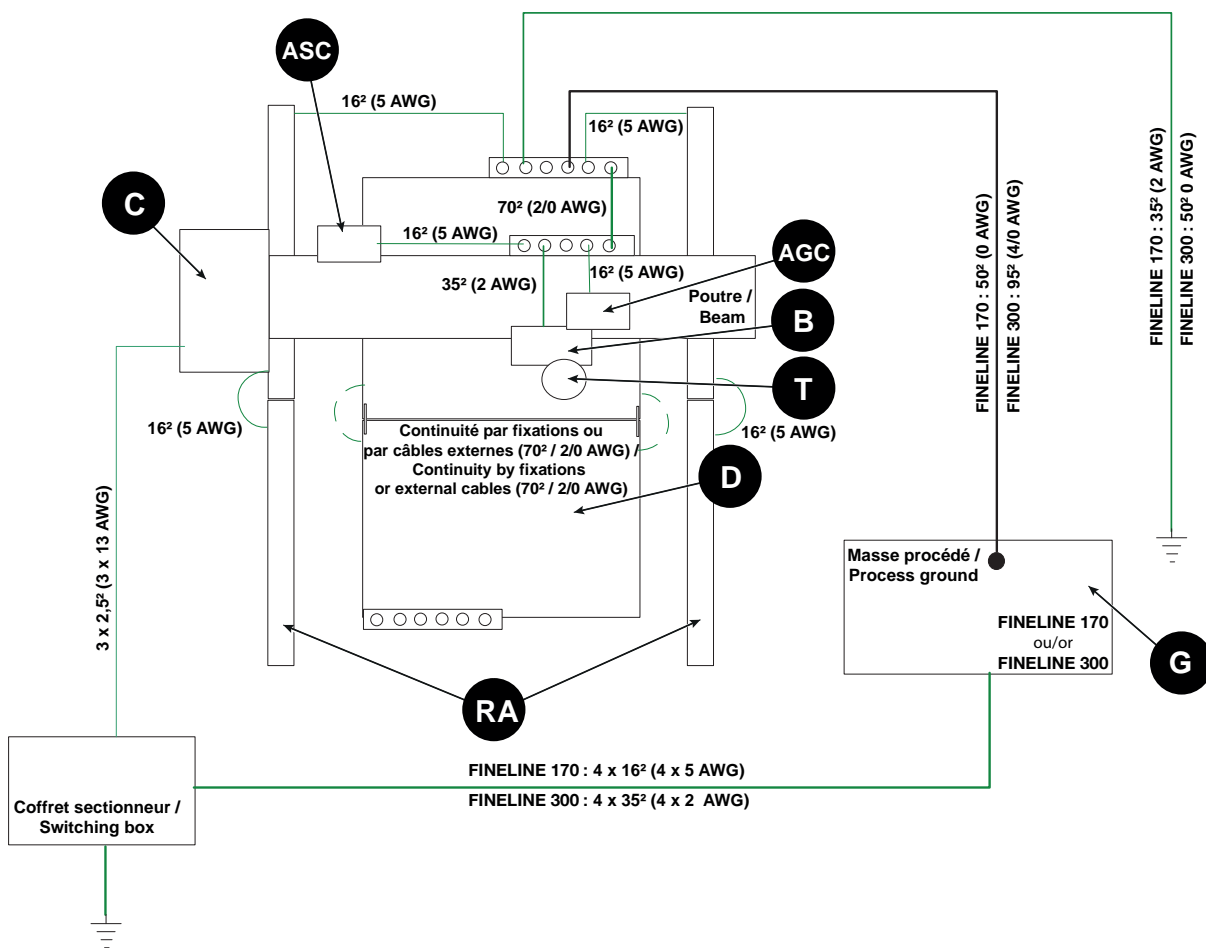

References

B	Shield	T	LC300M torch
C	Cupboard	RA	Rails
D	Cutting table	ASC	Arc strike controller
AGC	Gas controller	G	Power source

1 - Possibilities of the Fineline machine

This is a complete installation made up of several pieces of industrial equipment (power source, torch, control console, tool holder, bundles etc.) specially designed to allow automatic thermal cutting with a plasma jet.

NB: The speed and quality pair can be selected differently depending on the end destination of the cut parts.

Thermal cutting with a plasma jet is a fusion cutting process, followed by ejection of melted metal by the plasmagen gas.

Quality and productivity requirements: closer metallurgical, dimensional or geometrical tolerances, surface conditions, speed etc. make it necessary to use modern guiding machines.

The claimed performance can only be achieved if the machines can execute a satisfactory path at the required speeds.

2 - Installation integrated in Lincoln Electric machine

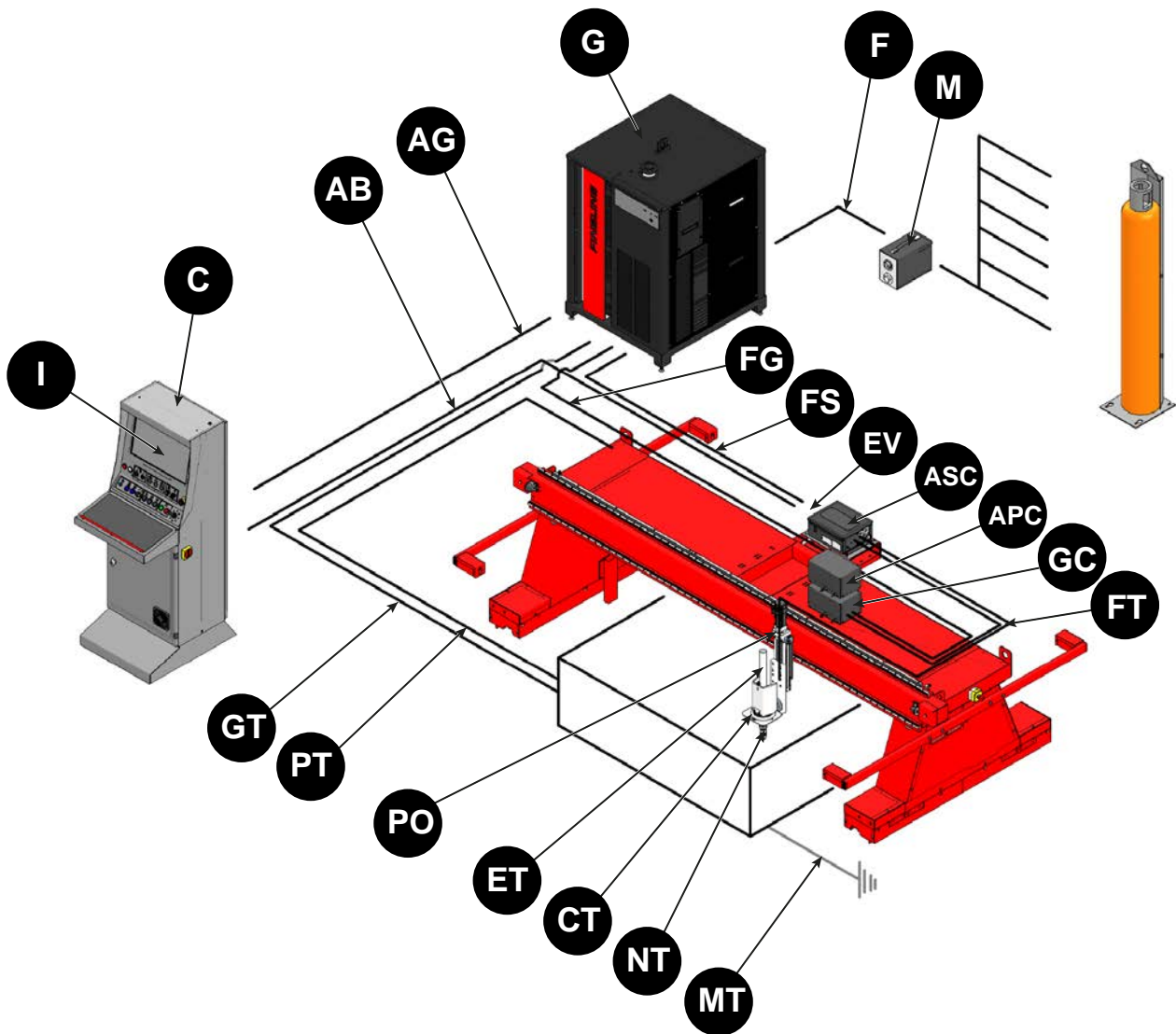

Integrated Fineline machine			
Reference	Description	Nominal	Part number
ASC	Torch connection unit		K4901-1
EV	(Optional) coolant shutoff solenoid valve <ul style="list-style-type: none"> Fixed console Local console 		P04152091NG P04152090NG
APC	Optional advanced process controller		P04151020NG
GC	Gas connection unit		BK300350
C	Cycle function assembly		-
I	HPC Digital Process III human machine interface		-
CT	Magnetic torch impact safety system		P04096903
ET	Torch connector: <ul style="list-style-type: none"> Torch connector Torch shank 		BK602623 BK602621
NT	Torch tip		BK602625
FT	Torch bundle, 4.6m Torch bundle, 6m Torch bundle, 7.5m		BK602604-15 BK602604-20 BK602604-25
G	Fineline 170 (CE) power source Fineline 170 (CSA) power source Fineline 300 (CE) power source Fineline 300 (CSA) power source		K4910-2 K4910-1 K4900-2 K4900-1
PO	THDi 160 tool holder THDi 350 tool holder THDi 180 c tool holder		P07054360 P07054370 P07006610
M	Mixer		P04150311
FS	Fineline 170/ASC box bundles	10 metres (32 feet) 15 metres (50 feet) 22.5 metres (75 feet) 30 metres (100 feet)	P04151061NG P04151062NG P04151063NG P04151064NG
	Fineline 300/ASC box bundles	10 metres (32 feet) 15 metres (50 feet) 22.5 metres (75 feet) 30 metres (100 feet)	P04151051NG P04151052NG P04151053NG P04151054NG
FG	Fineline 170 or Fineline 300/AGC bundles	10.5 metres (32 feet) 15 metres (50 feet) 22.5 metres (75 feet) 30.5 metres (100 feet) 38 metres (125 feet)	P04151070NG P04151071NG P04151072NG P04151073NG P04151074NG
F	Steel gas/ Fineline 170 or Fineline 300 bundles	5 metres (16 feet) 10 metres (32 feet) 15 metres (50 feet) 20 metres (65 feet)	P04151080NG P04151081NG P04151082NG P04151083NG
	Stainless steel gas/ Fineline 170 or Fineline 300 bundles	5 metres (16 feet) 10 metres (32 feet) 15 metres (50 feet) 20 metres (65 feet)	P04151090NG P04151091NG P04151092NG P04151093NG
	Stainless steel gas with mixer/ Fineline 170 or Fineline 300 bundles	5 metres (16 feet) 10 metres (32 feet) 15 metres (50 feet) 20 metres (65 feet)	P04151190NG P04151191NG P04151192NG P04151193NG

AB	Cabinet/AGC bundles	7.5 metres (25 feet) 10 metres (32 feet) 15 metres (50 feet) 22.5 metres (75 feet) 30.5 metres (100 feet) 38 metres (125 feet)	P04151200NG P04151201NG P04151202NG P04151203NG P04151204NG P04151205NG
AG	Cabinet/power source bundles	7.5 metres (25 feet) 10 metres (32 feet) 15 metres (50 feet) 22.5 metres (75 feet) 30.5 metres (100 feet) 38 metres (125 feet)	P04151210NG P04151211NG P04151212NG P04151213NG P04151214NG P04151215NG
GT	Table/ Fineline 170 bundles	10 metres (32 feet) 20 metres (65 feet) 40 metres (131 feet)	P04098040NG P04098041NG P04098042NG
	Table/ Fineline 300 bundles	10 metres (32 feet) 20 metres (65 feet) 40 metres (131 feet)	P04098060NG P04098061NG P04098062NG
MT	Equipotential Fineline 170 Table/Customer earth bundles	5 metres (16 feet) 10 metres (32 feet) 15 metres (50 feet) 20 metres (65 feet) 25 metres (82 feet) 30 metres (98 feet)	P04097915NG P04097920NG P04097922NG P04097924NG P04097925NG P04097926NG
	Equipotential Fineline 300 Table/Customer earth bundles	5 metres (16 feet) 10 metres (32 feet) 15 metres (50 feet) 20 metres (65 feet) 25 metres (82 feet) 30 metres (98 feet)	P04098080NG P04098081NG P04098082NG P04098083NG P04098084NG P04098085NG

3 - Gas connection unit (AGC: BK300350)

The gas connection unit is usually mounted on the tool holder carriage (mobile part).



Please refer to the document:

- BK5043-000111: FINELINE 170
- BK5043-000107: FINELINE 300



4 - Torch connection unit (ASC: K4901-1)

The torch connection unit is usually mounted on the beam of the cutting machine.



Please refer to the document:

- BK5043-000111: FINELINE 170
- BK5043-000107: FINELINE 300



5 - Fineline APC advanced process controller: BK300370)

The advanced process controller is mounted on the AGC unit.



Please refer to the document:

- BK8053-000117: Fineline APC advanced process controller



6 - THD (PO) tool holder and magnetic torch impact safety system (CT)



Please refer to the document:

- 86954568: THDi160 - THDi350 tool holder
- 86954569: THDi 180 c tool holder
- 86954606: Magnetic torch impact safety system

The functions of the tool holder (THDi) are:

- Z (vertical) axis management
- Holding the torch to avoid vibrations

The functions of the torch impact safety system are as follows:

- Reporting a mechanical impact on the torch
- Protecting the torch during a mechanical impact

The THDi tool holder is usually mounted on the tool holder carriage (mobile part).

Tool holder specifications						
		THDi 160	THDi 350	THDi 180 c		
Item no		P07054360	P07054370	P07006590		
Speed		15 m/min (590 inches/min)				
Travel		160 mm (6.3 inches)	350 mm (13.7 inches)	180 mm (7 inches)		
Max load		20 daN				
Weight		22.5 daN	27.5 daN	16 daN		
Dimensions (not including torch impact safety system)	Height	620 mm (24.4 inches)	810 mm (32 inches)	707 mm (27.8 inches)		
	Width	100 mm (3.9 inches)	100 mm (3.9 inches)	230 mm (9 inches)		
	Depth	80 mm (3.15 inches)	80 mm (3.15 inches)	80 mm (3.15 inches)		

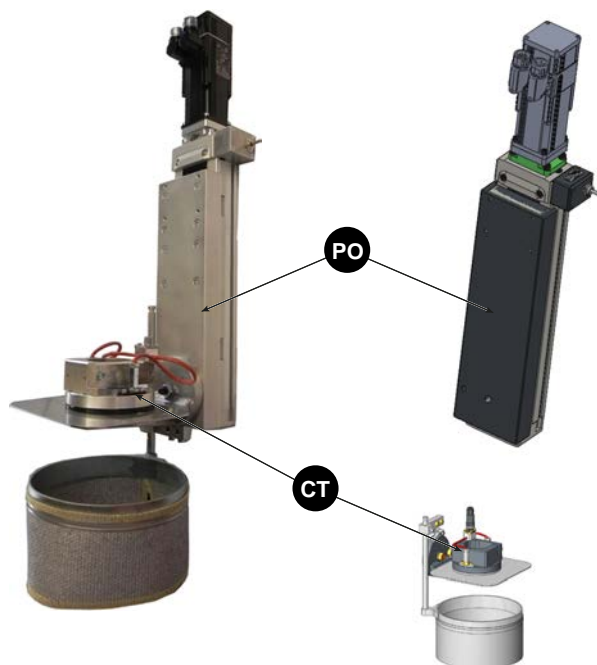

Torch impact safety system specifications		
	For THDi	For THDi c
Item no	P04096903	P07006610
Weight	5 daN	5 daN

7 - Torch connector (ET)

The functions of the connector are as follows:

- Acting as the intermediary between the torch connection unit (**ASC**) and the removable part of the torch
- Contributing to gas management

The torch connector is connected to the torch connection unit (**ASC**) on one side and the tool holder **THDi** on the other via the torch impact safety system.

Reference	Description	Part number	Weight
1	Torch bundle, 4.6 m (15 feet)	BK602604-15	
	Torch bundle, 6 m (20 feet)	BK602604-20	
	Torch bundle, 7.5 m (25 feet)	BK602604-25	
2	Torch shank	BK602621	0.43 daN
3	Torch connector	BK602623	0.34 daN
4	Torch tip	BK602625	0.62 daN

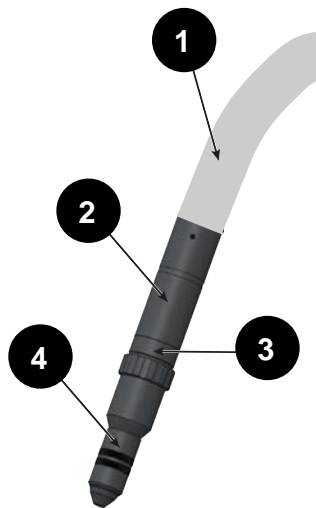

8 - Torch (NT)

The function of the torch is to diffuse gas and current so as to achieve high quality cutting.

The torch is fastened to the connector.

The **Fineline** machine is designed to operate with the **LC300M** torch.



Please refer to the document:

- BK5043-000111: FINELINE 170
- BK5043-000107: FINELINE 300

9 - Power source (G)

The function of the **Fineline 170** or **Fineline 300** power source is to regulate the cutting current based on the requested setpoints.

Fineline 170 can deliver 170A maximum.

Fineline 300 can deliver 300A maximum.

The power source is generally located close to the installation.



Please refer to the document:

- BK5043-000111: FINELINE 170
- BK5043-000107: FINELINE 300

10 - Refrigeration unit (G)

The function of the refrigeration unit is to cool the cutting torch. It is integrated into the **Fineline**.



Please refer to the document:

- BK5043-000111: FINELINE 170
- BK5043-000107: FINELINE 300

11 - (Optional) Fineline APC advanced process controller

The purpose of this unit is to allow cutting with lubrication and/or cutting with water as protection.



Please refer to the document:

- BK8053-000117: Fineline APC advanced process controller

12 - (Optional) EV coolant shutoff solenoid valve

This option is used with the overhead chain.

Switching off the power source cuts off the power supply and the output of coolant via solenoid valves.

This feature is used so as to not lose a large quantity of coolant while changing consumables.

1 - Installation conditions



The machine must be located in accordance with safety standards to keep personnel safe.



Arrangement of cables and hoses

The customer must provide the means to support and protect cables and hoses from mechanical, chemical or thermal damage from their source up to the entrance to the cable drag chain and from the machine up to the entrance to the control console.



The following conditions must be fulfilled before the equipment is installed.

1.1 Fluid supply

Provide the gas sources (cylinders, cylinder racks, evaporators etc.) and/or water (with the optional **APC**) below, each fitted with a regulator that can provide the recommended output and pressure values, and a stop valve in case of arrival by pipe.



Never exceed the 12 bar (174 PSI) pressure specified for the supply to the installation.

Supply pressures are controlled by the power source.



For starting up the gas sources, refer to the section:
“6-2 CYLINDER CHANGE PROCEDURE”
in the safety booklet 8695 7050

Conditions for the types of gas:

Cutting gas			
Fluids used	Purity type	Machine supply pressures (from relief valve exit)	Max. flow rates used
Carbon steel			
Argon (Ar)	99.99%	8.65 bar (+/- 1) (123 PSI +/- 14)	22 l/min (45 SCFH)
Oxygen	99.5%	8.65 bar (+/- 1) (123 PSI +/- 14)	43 l/min (92 SCFH)
Compressed air	*	8.65 bar (+/- 1) (123 PSI +/- 14)	118 l/min (250 SCFH)
Nitrogen	99.5%	8.65 bar (+/- 1) (123 PSI +/- 14)	60 l/min (125 SCFH)
Stainless steel, aluminium and alloys			
Argon (Ar)	99.99%	8.65 bar (+/- 1) (123 PSI +/- 14)	22 l/min (45 SCFH)
Compressed air	*	8.65 bar (+/- 1) (123 PSI +/- 14)	38 l/min (80 SCFH)
Nitrogen	99.5%	8.65 bar (+/- 1) (123 PSI +/- 14)	142 l/min (300 SCFH)
H17 (cylinder)	99.995%	8.65 bar (+/- 1) (123 PSI +/- 14)	60 l/min (125 SCFH)
H17 (reconstituted)	Nitrogen	99.95%	9 bar (+/- 0.5) (130 PSI +/- 7.2)
	Argon/hydrogen (35%)	99.99%	9 bar (+/- 0.5) (130 PSI +/- 7.2)
Optional APC			
Compressed air	*	9 bar (+/- 1) (130 PSI +/- 14)	354 l/min (750 SCFH)
Water (if cutting with water)		4 bar (+/- 1) (58 PSI +/- 14)	1.9 l/min (0.5 GPM)



* The quality of the compressed air used has a significant impact on cutting results.
IT MUST BE DRY AND FREE FROM OIL.
 Purity: ISO 8573 class 1.4.1

1.2 Electricity supply



For compliance with European safety standards, the connection to the electricity supply is to be made via a wall-mounted cabinet with an individual protective disconnecter with rating appropriate for the mains voltage and the consumption by the equipment

The protective disconnecter must offer breaking capacity > 50KA.

We market cabinets that meet the criteria set out. See the table below.

The service power depends on the supply voltage used.

A cable with an appropriate cross section must be provided to connect the disconnecter to the power source.

Consumption of the machine not including the power source:



For systems integrated in Lincoln Electric machines, please refer to the instructions of the machine and the machine utilities supply drawing.

Consumption of a Fineline 170 power source:

Power supply 3 phases + earth	400V
Nominal intensity (170A-210V)	69 A
Fuse rating	80 A aM
Fuse size	22x58
Power cable section	4x16 mm ² (4x5 AWG)
Cable part number	W000010104



The consumption values are stated for operation with 170 A - 210 V while cutting.

Consumption of a Fineline 300 power source:

Power supply 3 phases + earth	400V
Nominal intensity (300A-210V)	123 A
Fuse rating	125 A aM
Fuse size	22x58
Power cable section	4x35 mm ² (4x2 AWG)
Cable part number	W000010106



The consumption values are stated for operation with 300 A - 210 V while cutting.

Disconnecting box:

	Supply 3 phases + earth	400V
FINELINE 170	Single torch	P06942318 NG
	Dual torch	P06942322 NG
FINELINE 300	Single torch	P06942326 NG
	Dual torch	P06942328 NG

1.3 Operating temperature

The optimum operating conditions are from 0 °C 40 °C (32°F to 104°F).

2 - Destruction and scrapping



At the end of the life of the machine, the owner must destroy it and scrap it according to applicable regulations and standards using the different recovery channels for the materials used.

3 - Unpacking and handling



Please refer to the document:

- BK5043-000111: FINELINE 170
- BK5043-000107: FINELINE 300
- BK8053-000117: Fineline APC advanced process controller (optional)



During any lifting operations, the use of appropriate PPE (Personal Protective Equipment) is MANDATORY.



The components of the installation may only be transported using the slinging points provided, with appropriate slinging equipment.



All lifting operations must be carried out by qualified personnel who are aware of applicable safety standards.



Lifting without these necessary precautions will expose personnel and property to risks.

4 - Installation



Please refer to the document:

- BK5043-000111: FINELINE 170
- BK5043-000107: FINELINE 300
- BK8053-000117: Fineline APC advanced process controller (optional)

4.1 Fluid connections

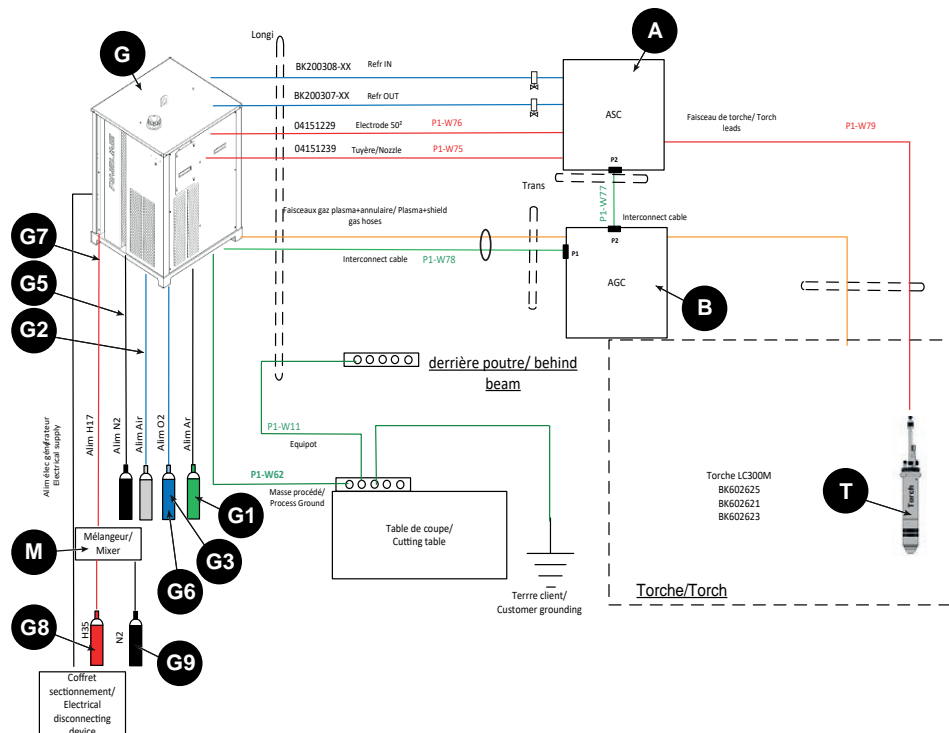

Reference	Description
A	Torch connection unit (ASC)
B	Gas connection unit (AGC)
G	Fineline 170 power source Fineline 300 power source
T	Torch + bundle
M	Mixer (for H17)
G1	Steel cutting: Argon (Ar) (marking)
G2	Steel cutting: Air (N2O2) (annular gas)
G3	Steel cutting: Oxygen (O2) (cutting/annular gas)
G4	Stainless steel cutting: Argon (Ar) (marking gas)
G5	Stainless steel cutting - Nitrogen (N2) (annular gas, pilot gas, marking) Steel cutting: pilot, marking
G6	Stainless steel cutting: Air (N2O2) (cutting/annular gas)
G7	Stainless steel cutting: H17 (cutting gas)
G8	Optional mixer: Stainless steel cutting: H35 (for H17)
G9	Optional mixer: Stainless steel cutting: Nitrogen (N2) (for H17)
EV	Optional coolant shutoff

4.2 Electrical connections

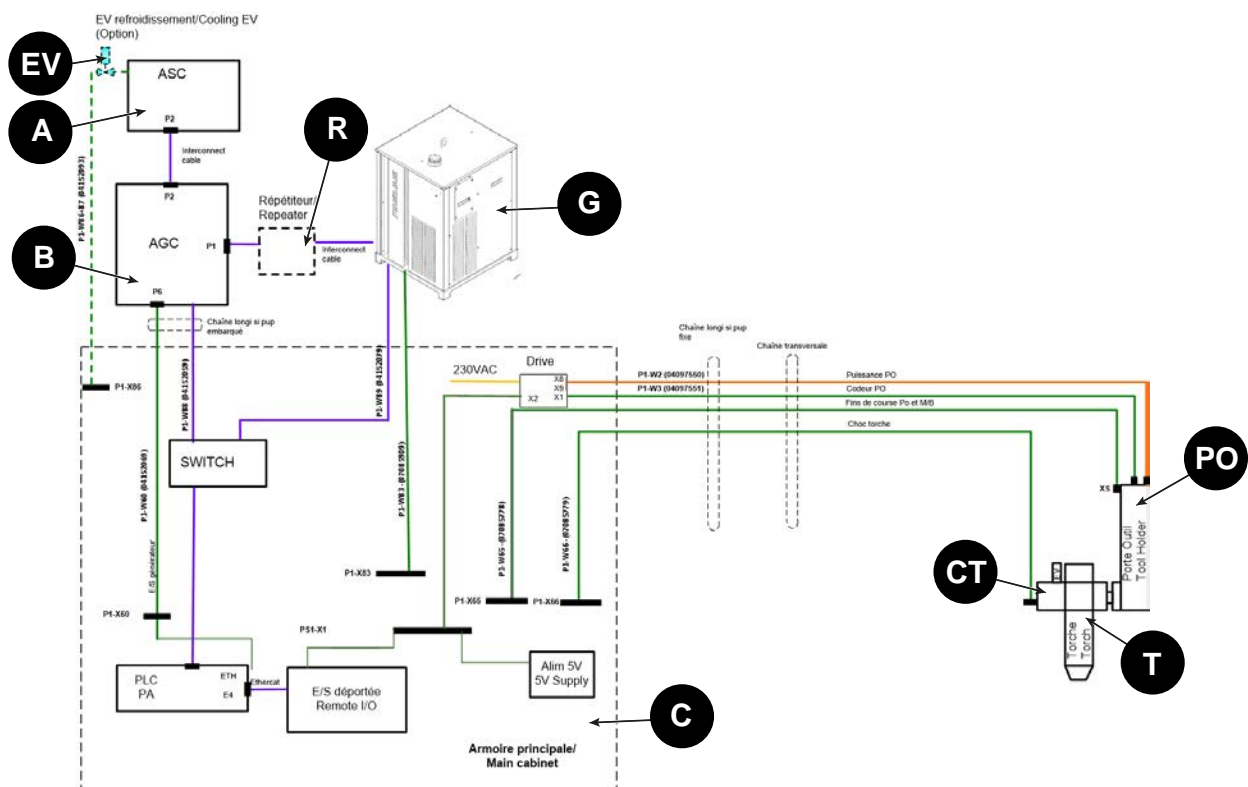

Reference	Description
A	Torch connection unit (ASC)
B	Gas connection unit (AGC)
C	Cycle function assembly
G	Fineline 170 power source Fineline 300 power source
T	Torch + bundle
PO	Tool holder
CT	Magnetic torch impact safety system
R	Repeater (if the bundle is more than 22.5m long (75 feet))
EV	Optional coolant shutoff via solenoid valve

4.3 Assembly

The cycle function is assembled in the factory, in the main cabinet.

4.4 Connections

The cycle function is connected in the factory, in the main cabinet.

5 - Installation of the tool holder THD



Please refer to the document:

- 86954568: THDi160 - THDi350 tool holder
- 86954569: THDi 180 c tool holder

6 - Installation of the torch connection unit (ASC)



- Please refer to the document:
- BK5043-000111: FINELINE 170
 - BK5043-000107: FINELINE 300

7 - Installation of the torch connector and torch



- Please refer to the document:
- BK5043-000111: FINELINE 170
 - BK5043-000107: FINELINE 300

8 - Installation of the gas connection unit (AGC)



- Please refer to the document:
- BK5043-000111: FINELINE 170
 - BK5043-000107: FINELINE 300

9 - Installation of the power source and refrigerant unit



- Please refer to the document:
- BK5043-000111: FINELINE 170
 - BK5043-000107: FINELINE 300

10 - Installation and connections of optional APC



- Please refer to the document:
- BK8053-000117: Fineline APC advanced process controller (optional)

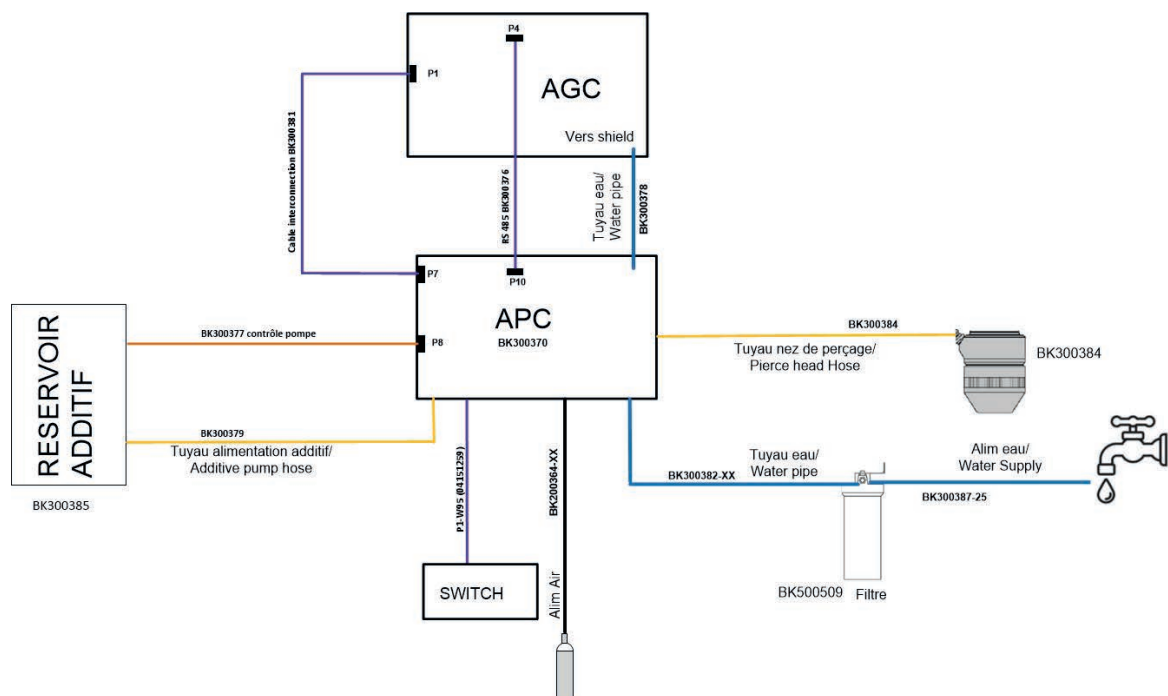

IMPORTANT: After connecting, make sure there are no leaks (water, gas or air), and that no pipe is bent.

1 - Operator controls

1.1 HMI controls

All the HMI controls can be found in the literature of the **HPC Digital Process** in the sections relating to the **Fineline** machine



Please refer to the document:
• 86954995: HPC DIGITAL PROCESS III

1.2 Torch movement controls

The height of each torch can be modified in slow speed at any time (except if there is a fault or if the torch is not selected),. To do so, use the buttons located in the HMI in the sections relating to the **Fineline** machine.



Please refer to the document:
• 86954995: HPC DIGITAL PROCESS III

2 - Adjustment

2.1 Adjustment of process parameters

Process parameters can be adjusted from the HMI. See the literature of the **HPC Digital Process**, sections relating to the **Fineline** machine.



Please refer to the document:
• 86954995: HPC DIGITAL PROCESS III

The part program particularities (size and location of striking, cutting quality etc.) also influence cutting quality. The post-processor must comply with the recommendations of **Lincoln Electric**.



Please refer to the document:
• BK5043-000111: FINELINE 170
• BK5043-000107: FINELINE 300

3 - Change in gas supply

When the gas supply is changed (cylinder change, for example), we recommend the following:

- Shut the cylinder to change
- Carry out a gas test on the power source till the fault is reported
- Press the emergency stop button
- Change the cylinder in accordance with the supplier's recommendations.
- Make sure that there is no dust or pollution (CAUTION! Risk of explosion with oxygen),
- Check that there is no leak after each cylinder change.

4 - Change in consumables

The power source must be switched off when the consumables are changed, due to the electrical hazards, and circulation in the torch cooling circuit. An emergency stop switches off the power module of the power source.

The torch tip must be tightened fully. Then test for leaks with 1000 bulles leak tester.

5 - Cycles

Cycle auto coupe plasma et palpage avec apprentissage, hauteur non connue

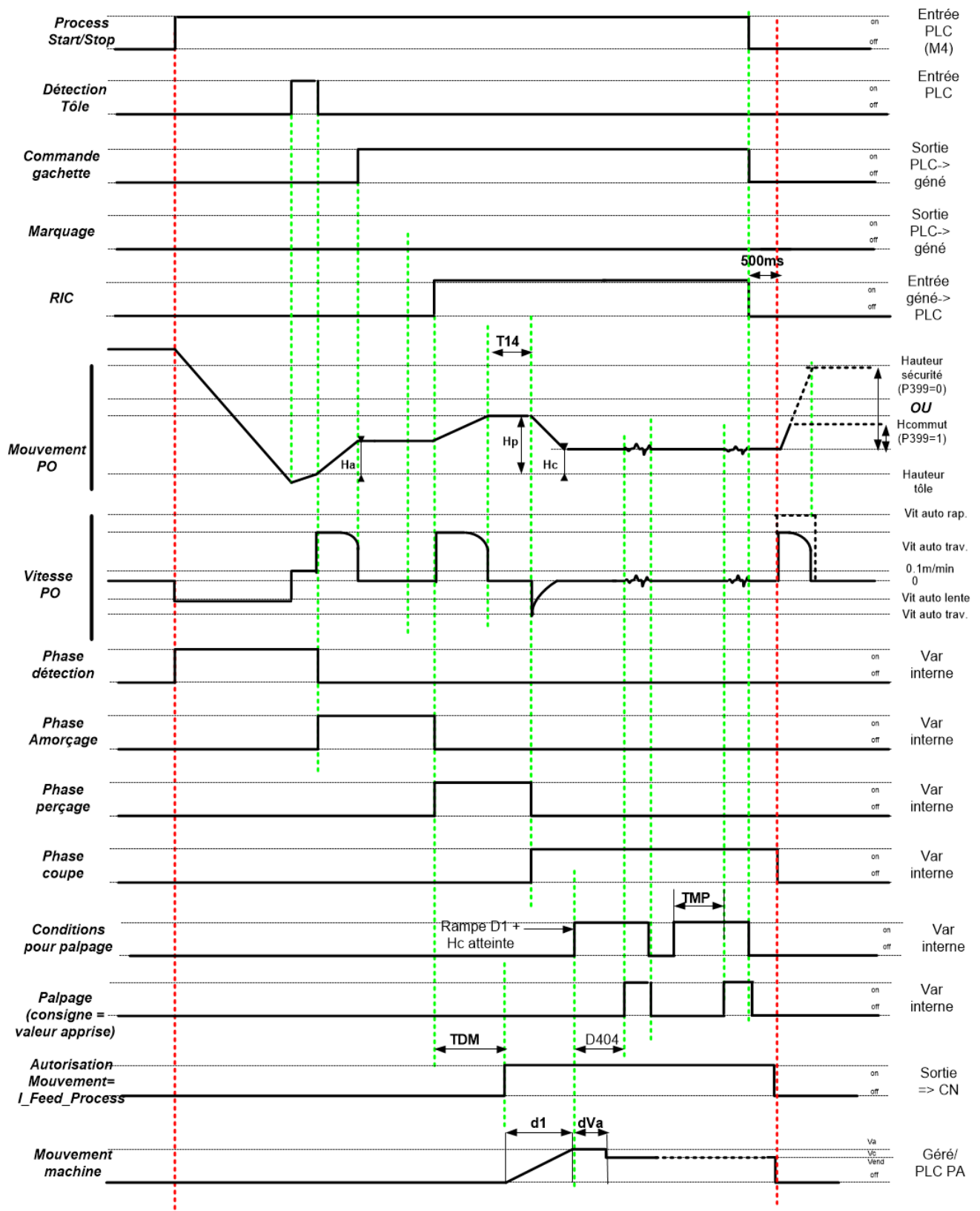

TDM = Tempo départ mouvement
 T14 = Temps de maintien à hauteur de retract
 dVa : Distance vitesse d'amorçage active
 D1 = Distance d'accélération amorçage
 D404 = Distance apprentissage tension

Ha = Hauteur d'amorçage
 Hp = Hauteur rétract
 Hc = Hauteur coupe
 TMP : Tempo de mise en palpage

1 - Care

For a long and trouble-free life, the machine requires a minimum level of care and maintenance.

The frequency of such maintenance is indicated for production in one work shift per day. For higher production rates, increase the maintenance frequencies accordingly.

Your maintenance department could photocopy these pages to track maintenance frequencies and times and the operations completed (tick the appropriate box).



All maintenance must be carried out by specialised personnel who have read and understood this manual.



Electricity technician
Qualified operator with the ability to work in normal conditions on electrical parts for regulation, maintenance and repair.



Mechanical technician
Specialised technician authorised to carry out complex and exceptional mechanical operations.



To maintain the Fineline power source, refer to the document:

- BK5043-000111: FINELINE 170
- BK5043-000107: FINELINE 300
- BK8053-000117: Fineline APC advanced process controller (optional)

Every week

Date of the operation:



Inspect the working of the gas circuit: pressure gauge, pressure reducer valve, solenoid valve, valve, fittings etc.
 NB: if the piping shows the least sign of fatigue, wear and tear or damage, it should be replaced by an identical standardised pipe. Hoses may not be repaired (with gummed tape, for instance).

Check the condition of all electrical cables and insulation, particularly close to the torch and in the cable drag chain (change them if required). Check that electrical wires are tightened.

2 - Troubleshooting

2.1 Electrical problems



Reminder: all work is to be carried out by approved and trained personnel.

If any fault occurs in the plasma equipment due to an electrical problem, first check the fuses. Before opening the cabinet, switch the machine off. Using the emergency stop does not mean that there is no voltage in the box.

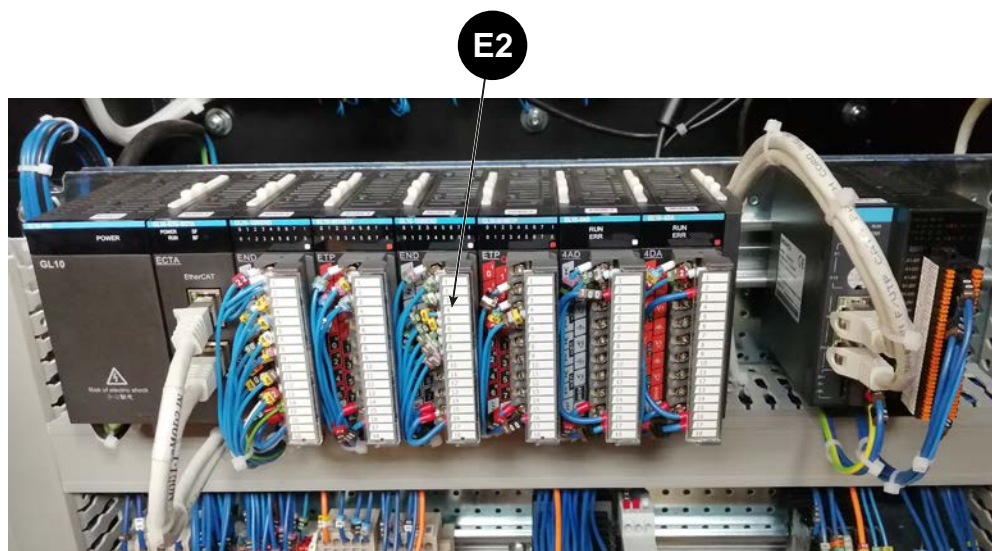

While troubleshooting, the technician may ask you to check the status of the indicators on the **E2** inputs/ outputs and also those on each of the solenoid valves, which have an indicator that goes on when the valve supply is on. On the PLC, faulty inputs/outputs are red.

2.2 Explanation of alarms: overall process fault

These faults are common to the different processes.

Alarm	Probable causes	Possible remedies
3 : Loss of communication with the PLC	Communication between the HMI and the NC PLC has been interrupted for 10 seconds (watchdog)	Check proper Ethernet addressing and reset communication
1001 : The emergency stop is active!	The process cannot start without switching on the power to the machine	Remove the cause of the emergency stop and switch the power back on
1011 = Cycle stop for Head Collision. Jog in limited speed	Probe impact (oxy cutting) or torch impact (plasma)	Correct the fault, raise the tool holder and clear the alarm

2.3 Explanation of alarms: Fineline plasma

The alarms indicating **Fineline** plasma cutting process faults are displayed on the HMI.

Alarm	Probable causes	Possible remedies
1071 : No operating feedback from the filter	The filter has been activated, but the feedback indicating that it is working properly is not correct	Check that the extraction system is being powered.
1254 = Electrode voltage fault/part plasma1	The voltage between the electrode and the part increased too suddenly. Often due to a break in the arc.	Replace the plasma on the plate and restart cutting.
1255 = Electrode voltage fault/part plasma2	The voltage between the electrode and the part increased too suddenly. Often due to a break in the arc.	Replace the plasma on the plate and restart cutting.
1262 = Upper limit fault and plasma tool holder being regulated	One of the upper limit switches of a torch being regulated is active.	Mechanically raise the tool holder so that it can cut higher
1263 = Plasma tool holder in low position fault	One of the lower limit switches of the torch is active	Correct the fault, raise the tool holder and clear the alarm
1264 = Striking fault or power source 1 off	A request for pilot arc has been made, but the arc does not transfer	Switch on the power source or change the consumables or lower the transfer height.
1265 = Striking fault or power source 2 off	A request for pilot arc has been made, but the arc does not transfer	Switch on the power source or change the consumables or lower the transfer height.
1268 = Plasma 1 electric sensing fault	Slag blocked in the sensing cap	Inspect the consumables OR Select a higher cutting intensity (aluminium) OR Disconnect the sensing wire to use mechanical sensing
1269 = Plasma 2 electric sensing fault	Slag blocked in the sensing cap	Inspect the consumables OR Select a higher cutting intensity (aluminium) OR Disconnect the sensing wire to use mechanical sensing
1272 = plasma 1 arc break fault	The arc has disappeared during cutting	Set the program back on the plate or restart the cycle
1273 = plasma 2 arc break fault	The arc has disappeared during cutting	Set the program back on the plate or restart the cycle
01290 = Fineline watchdog fault	Communication between the machine and power source was broken	Check the connections and restart the machine
01291 = Cutting requested and Fineline error fault	A plasma cut has been requested, but Fineline reports an error	Identify and correct the error in the Fineline
01292 = Cut requested and Fineline 2 error fault	A plasma cut has been requested, but Fineline reports an error	Identify and correct the error in the Fineline
01293 = Fineline 1 cutting settings not correct	The cutting settings sent (material, thickness, intensity, type of consumable) do not match any known setting of the power source	Select another setting OR enquire with Lincoln Electric after-sales service
01294 = Fineline 2 cutting settings not correct	The cutting settings sent to Fineline 2 (material, thickness, intensity, type of consumable) do not match any known setting of the power source	Select another setting OR enquire with Lincoln Electric after-sales service
01295 = Request for Fineline 1 purge	The gases used require a system purge on Fineline 1	Carry out a manual purge OR stop/restart power source 1

01296 = Request for Fineline 2 purge	The gases used require a system purge on Fineline 2	Carry out a manual purge OR stop/restart power source 2
--	--	--

2.4 Fineline power source faults



Please refer to the document:

- BK5043-000111: FINELINE 170
- BK5043-000107: FINELINE 300

2.5 Gas controller faults



Please refer to the document:

- BK5043-000111: FINELINE 170
- BK5043-000107: FINELINE 300

2.6 Optional APC faults



Please refer to the document:

- BK8053-000117: Fineline APC advanced process controller (optional)

2.7 Other faults

Alarm	Probable causes	Possible remedies
The tool-holder does not move	The torch is not selected Lower limit switch (HMI alarm) Torch impact safety system (HMI alarm) Upper limit switch (no alarm)	Select the torch manually Correct the fault and set the tool holder position if required. Correct the fault and clear the alarm Correct the fault and set the tool holder position if required.
Two torches cannot be selected	The two torches are not identical (type)	Select two identical torches
Cutting cannot be started	Lack of extraction or ineffective extraction	Start/clean the extraction before cutting
Cutting is not correct	Several possible causes.	Refer to the process training manual
Incorrect cutting height	The tool holder speed offset has not been set. The plate is not on fixed supports	Adjust the variable drive speed offset Reposition the plate or change the sensing method (using pilot arc)

3 - Maintenance of the tool holder THD



- Please refer to the document:
- 86954568: THDi160 - THDi350 tool holder
 - 86954569: THDi 180 c tool holder

4 - Maintenance of the Fineline power source



- Please refer to the document:
- BK5043-000111: FINELINE 170
 - BK5043-000107: FINELINE 300

5 - Maintenance of the gas control unit



- Please refer to the document:
- BK5043-000111: FINELINE 170
 - BK5043-000107: FINELINE 300

6 - Maintenance of the strike controller



- Please refer to the document:
- BK5043-000111: FINELINE 170
 - BK5043-000107: FINELINE 300

7 - Maintenance of the torch LC300M



- Please refer to the document:
- BK5043-000111: FINELINE 170
 - BK5043-000107: FINELINE 300

8 - Maintenance of the optional APC installation



- Please refer to the document:
- BK8053-000117: Fineline APC advanced process controller (optional)

9 - Spare parts

Ordering procedure:

Almost all the parts of a machine or installation are referenced in the photographs and sketches.

The descriptive tables contain three types of item:

- items normally held in stock: ✓
- items not held in stock: ✗
- articles upon request: no reference

(For such parts, please complete the list of parts page and send us a copy. In the Order column, state the number of parts required and indicate the type and number of your equipment.)

For items referenced in the photographs or sketches but not included in the tables, please send us a copy of the relevant page and highlight the relevant reference.

Example:

Ref.	Part no	Stock	Order	Description
E1	W000XXXXXX	✓		Machine interface board
G2	W000XXXXXX	✗		Flow meter
A3	P9357XXXX			Printed front plates

✓	normally held in stock.
✗	not in stock
	upon request.

- While ordering parts, please indicate the quantity and note the number of your machine in the box above.

 Type <input type="text"/> Matricule <input type="text"/>	TYPE:
	Number:

9.1. Main parts

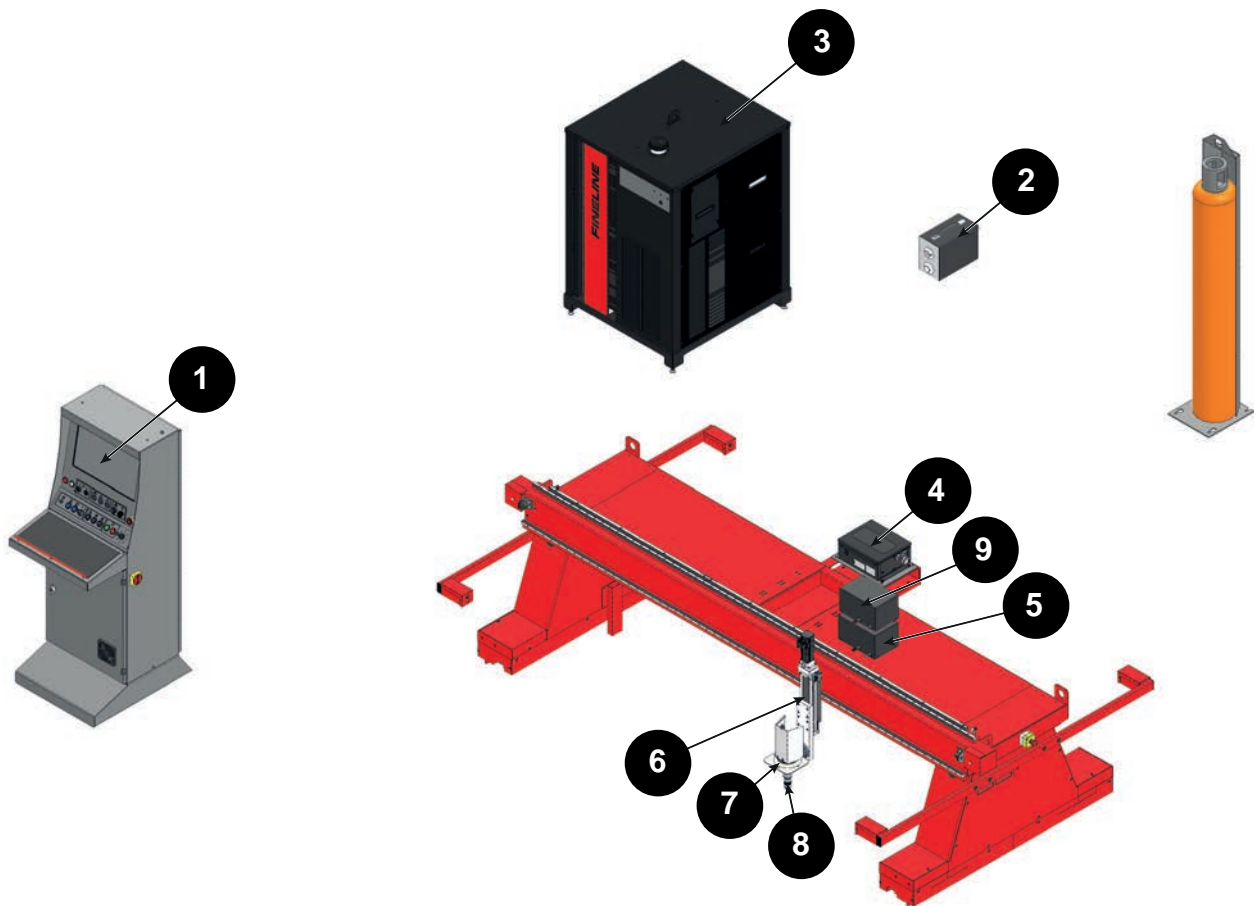

✓	normally held in stock.
✗	not in stock upon request.

Ref.	Part no	Stock	Order	Description
1				HPC DIGITAL PROCESS III (Please refer to the document: 86954995)
2	AS-CS-04150311	✗		Gas mixer
3				Fineline power source (Please refer to the document: BK8053-000111 (Fineline 170) or BK8053-000107 (Fineline 300))
4				Arc strike controller (ASC) (Please refer to the document: BK8053-000111 (Fineline 170) or BK8053-000107 (Fineline 300))
5				(AGC gas control unit) (Please refer to the document: BK8053-000111 (Fineline 170) or BK8053-000107 (Fineline 300))
6				THD tool holder (Please refer to the document: 86954568)
7				Magnetic torch impact safety system (Please refer to the document: 86954606)
8				Torch LC300M + Torch bundle (Please refer to the document: BK8053-000111 (Fineline 170) or BK8053-000107 (Fineline 300))
9				APC unit (Please refer to the document: BK8053-000117: Fineline APC advanced process controller)

- While ordering parts, please indicate the quantity and note the number of your machine in the box above.

 Type <input type="text"/> Matricule <input type="text"/>	TYPE:
	Number:

9.2 Bundle maintenance

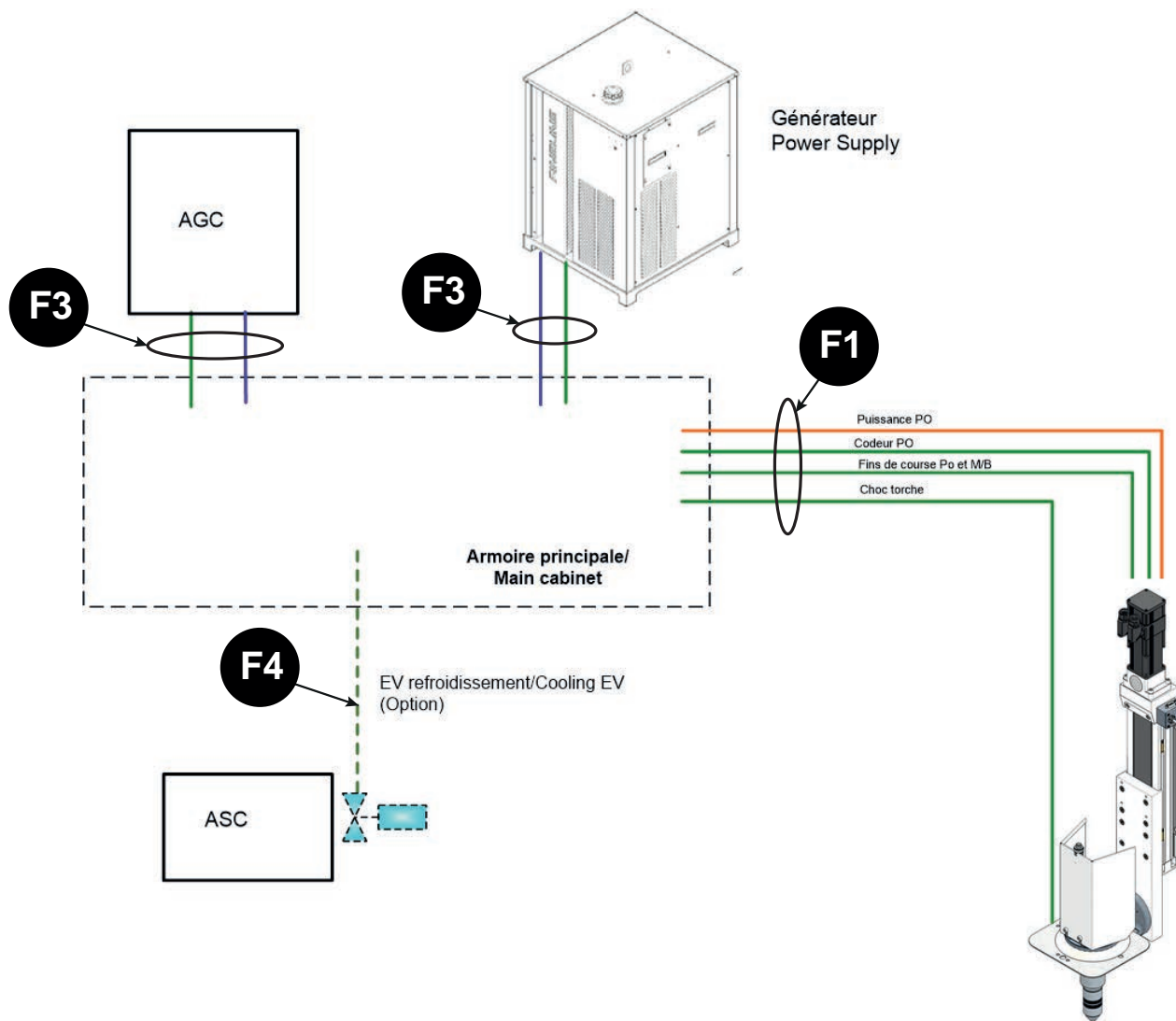

✓	normally held in stock.
X	not in stock upon request.

Ref.	Part no	Stock	Order	Description
F1	P07085880			THD bundle, 8m (26 feet)
	P07085881			THD bundle, 10m (32 feet)
	P07085882			THD bundle, 12m (39 feet)
	P07085883			THD bundle, 14m (45 feet)
	P07085884			THD bundle, 16m (52 feet)
	P07085885			THD bundle, 18m (59 feet)
	P07085886			THD bundle, 20m (65 feet)
F2	P04151210			Cabinet/power source bundle, 7.5m (24 feet)
	P04151212			Cabinet/power source bundle, 15m (50 feet)
	P04151213			Cabinet/power source bundle, 22.5m (73 feet)
	P04151214			Cabinet/power source bundle, 30m (100 feet)
F3	P04151200			Cabinet/AGC bundle, 7.5m (25 feet)
	P04151202			Cabinet/AGC bundle, 15m (50 feet)
	P04151203			Cabinet/AGC bundle, 22.5m (75 feet)
	P04151204			Cabinet/AGC bundle, 30.5m (100 feet)
	P04151205			Cabinet/AGC bundle, 38m (125 feet)
F4	P04152093			Coolant shutoff SV bundle (set of 2) (length depending on machine)

- While ordering parts, please indicate the quantity and note the number of your machine in the box above.

 Type <input type="text"/> Matricule <input type="text"/>	TYPE:
	Number:

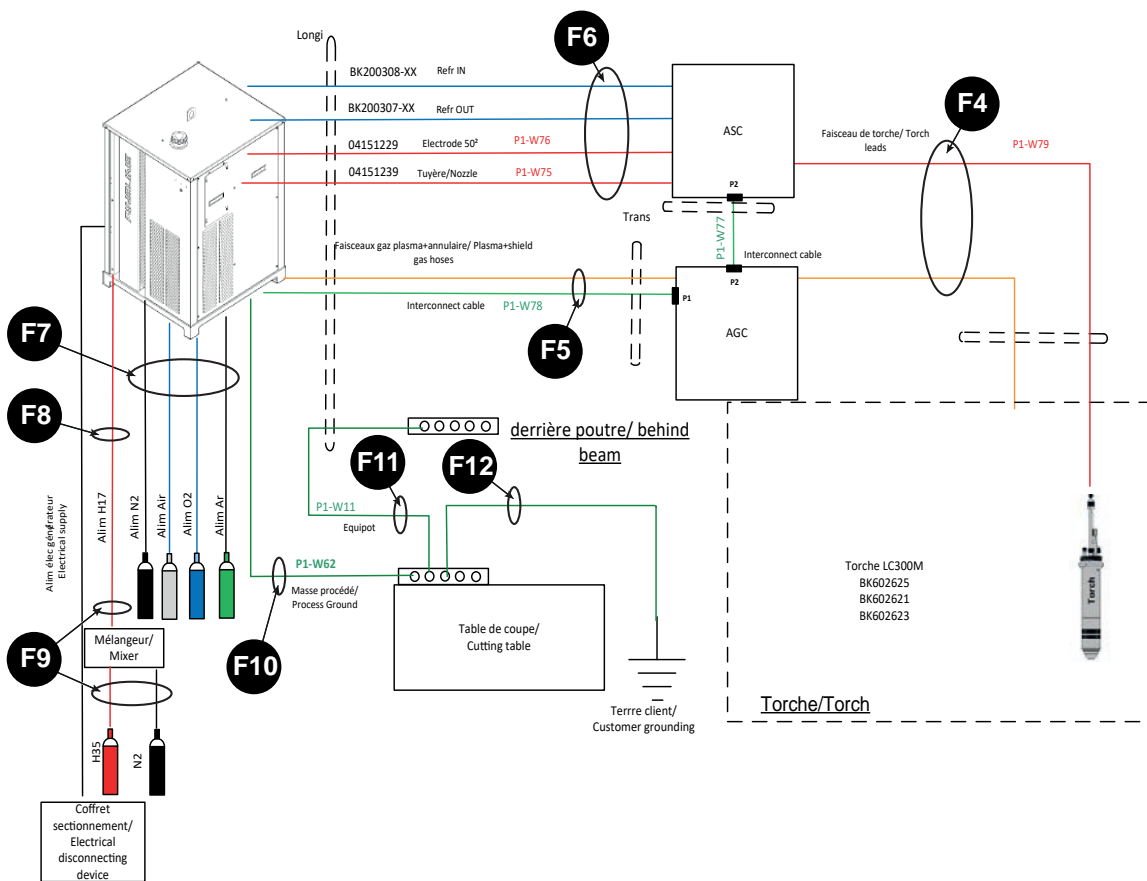

✓	normally held in stock.
✗	not in stock
	upon request.

Ref.	Part no	Stock	Order	Description
F4	BK602604-15	✗		Torch bundle, 4.5m (15 feet)
	BK602604-20	✗		Torch bundle, 6m (20 feet)
	BK602604-25	✗		Torch bundle, 7.5m (25 feet)
F5	P04151070			Fineline 170 & 300/ASC bundle, 10m (32 feet)
	P04151071			Fineline 170 & 300/ASC bundle, 15m (50 feet)
	P04151072			Fineline 170 & 300/ASC bundle, 22.5m (75 feet)
	P04151073			Fineline 170 & 300/ASC bundle, 30.5m (100 feet)
	P04151074			Fineline 170 & 300/ASC bundle, 38m (125 feet)
F6	P04151051			Fineline 300/ASC bundle, 10m (32 feet)
	P04151052			Fineline 300 /ASC bundle, 15m (50 feet)
	P04151053			Fineline 300 /ASC bundle, 22.5m (75 feet)
	P04151054			Fineline 300/ASC bundle, 30m (98 feet)
	P04151061			Fineline 170/ASC bundle, 10m (32 feet)
	P04151062			Fineline 170 /ASC bundle, 15m (50 feet)
	P04151063			Fineline 170 /ASC bundle, 22.5m (75 feet)
	P04151064			Fineline 170/ASC bundle, 30m (98 feet)
F7	P04151080			Steel/ Fineline 170 & 300 gas bundles, 5m (16 feet)
	P04151081			Steel/ Fineline 170 & 300 gas bundles, 10m (32 feet)
	P04151082			Steel/ Fineline 170 & 300 gas bundles, 15m (50 feet)
	P04151083			Steel/ Fineline 170 & 300 gas bundles, 20m (65 feet)













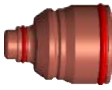













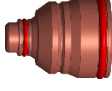













F8	P04151090			Stainless steel/ Fineline 170 & 300 gas bundles, 5m (16 feet)
	P04151091			Stainless steel/ Fineline 170 & 300 gas bundles, 10m (32 feet)
	P04151092			Stainless steel/ Fineline 170 & 300 gas bundles, 15m (50 feet)
	P04151093			Stainless steel/ Fineline 170 & 300 gas bundles, 20m (65 feet)
F9	P04151190			Stainless steel with mixer/ Fineline 170 & 300 gas bundles, 5m (16 feet)
	P04151191			Stainless steel with mixer/ Fineline 170 & 300 gas bundles, 10m (32 feet)
	P04151192			Stainless steel with mixer/ Fineline 170 & 300 gas bundles, 15m (50 feet)
	P04151193			Stainless steel with mixer/ Fineline 170 & 300 gas bundles, 20m (65 feet)
F10	P04098095			Fineline 300 ground/table bundle, 10m (32 feet)
	P04098096			Fineline 300 ground/ table bundle, 20m (65 feet)
	P04098097			Fineline 300 ground/table bundle, 40m (131 feet)
	P04098090			Fineline 170 ground/table bundle, 10m (32 feet)
	P04098091			Fineline 170 ground/ table bundle, 20m (65 feet)
	P04098092			Fineline 170 ground/table bundle, 40m (131 feet)
F11	P04097980			Beam/table equipotential bundle, 9m (29 feet)
	P04097981			Beam/table equipotential bundle, 10m (32 feet)
	P04097982			Beam/table equipotential bundle, 12m (39 feet)
	P04097983			Beam/table equipotential bundle, 14m (45 feet)
	P04097984			Beam/table equipotential bundle, 16m (52 feet)
	P04097985			Beam/table equipotential bundle, 18m (59 feet)
	P04097986			Beam/table equipotential bundle, 20m (65 feet)
	P04097987			Beam/table equipotential bundle, 25m (82 feet)
	P04097988			Beam/table equipotential bundle, 30m (98 feet)
	P04097989			Beam/table equipotential bundle, 35m (114 feet)
	P04097990			Beam/table equipotential bundle, 40m (131 feet)
F12	P04098080			Fineline 300 Customer/ table equipotential bundle, 5m (16 feet)
	P04098081			Fineline 300 Customer/ table equipotential bundle, 10m (32 feet)
	P04098082			Fineline 300 Customer/ table equipotential bundle, 15m (50 feet)
	P04098083			Fineline 300 Customer/ table equipotential bundle, 20m (65 feet)
	P04098084			Fineline 300 Customer/ table equipotential bundle, 25m (82 feet)
	P04098085			Fineline 300 Customer/ table equipotential bundle, 30m (98 feet)
	P04098086			Fineline 300 Customer/ table equipotential bundle, 35m (114 feet)
	P04098087			Fineline 300 Customer/ table equipotential bundle, 40m (131 feet)
	P04097915			Fineline 170 Customer/ table equipotential bundle, 5m (16 feet)
	P04097920			Fineline 170 Customer/ table equipotential bundle, 10m (32 feet)
	P04097922			Fineline 170 Customer/ table equipotential bundle, 15m (50 feet)
	P04097924			Fineline 170 Customer/ table equipotential bundle, 20m (65 feet)
	P04097925			Fineline 170 Customer/ table equipotential bundle, 25m (82 feet)
	P04097926			Fineline 170 Customer/ table equipotential bundle, 30m (98 feet)
	P04097927			Fineline 170 Customer/ table equipotential bundle, 35m (114 feet)
P04097928			Fineline 170 Customer/ table equipotential bundle, 40m (131 feet)	

- While ordering parts, please indicate the quantity and note the number of your machine in the box above.

	TYPE:
	Number:

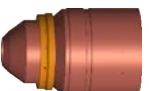
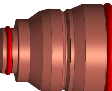











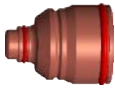













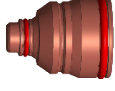











9.3 Selection of consumables

Mild steel
Plasma gas: Oxygen
Shield gas: Air*

	External cover	Protective nozzle	Internal cover	Nozzle	Diffuser	Electrode	Immersion tube
30 A	BK602365	BK602340	BK602338	BK602312	BK602354	BK602300	BK1111-200216
							
80 A	BK602365	BK602342	BK602338	BK602314	BK602356	BK602301	BK1111-200216
							
140 A	BK602365	BK602343	BK602339	BK602315	BK602358	BK602309	BK1111-200216
							
170 A	BK602365	BK602348	BK602332	BK602316	BK602357	BK602302	BK1111-200216
							
200 A	BK602365	BK602345	BK602332	BK602317	BK602359	BK602304	BK1111-200216
							
300 A	BK602365	BK602346	BK602369	BK602318	BK602360	BK602305	BK1111-200216
							

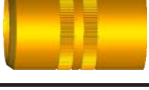

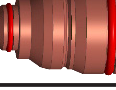

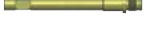









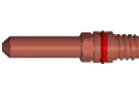



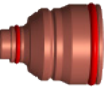

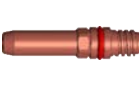



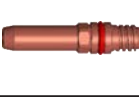

* Shield gas at 30A: Oxygen

Stainless steel
Plasma gas: Air
Shield gas: Nitrogen*

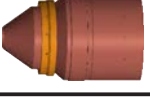
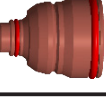

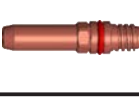
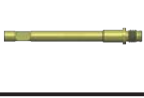

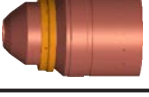
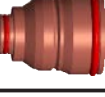

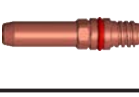
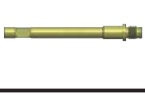







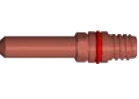





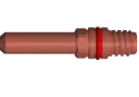







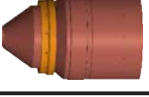
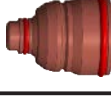

	External cover	Protective nozzle	Internal cover	Nozzle	Diffuser	Electrode	Immersion tube
30 A	BK602365	BK602341	BK602344	BK602313	BK602355	BK602303	BK1111-200216
							
80 A	BK602365	BK602342	BK602338	BK602314	BK602356	BK602301	BK1111-200216
							
140 A	BK602365	BK602343	BK602339	BK602315	BK602358	BK602309	BK1111-200216
							
170 A	BK602365	BK602348	BK602332	BK602316	BK602357	BK602302	BK1111-200216
							
200 A	BK602365	BK602345	BK602332	BK602317	BK602359	BK602304	BK1111-200216
							
300 A	BK602365	BK602346	BK602369	BK602319	BK602360	BK602305	BK1111-200216
							

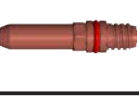
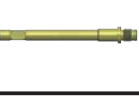
* Shield gas at 30A: Air

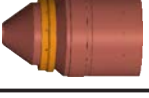
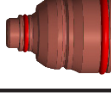
Stainless steel
Plasma gas: H17
Shield gas: Nitrogen

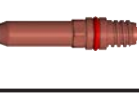
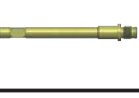
	External cover	Protective nozzle	Internal cover	Nozzle	Diffuser	Electrode	Immersion tube
80 A	BK602365	BK602342	BK602347	BK602325	BK602354	BK602310	BK1111-200216
							
140 A	BK602365	BK602352	BK602339	BK602327	BK602358	BK602311	BK1111-200216
							
170 A	BK602365	BK602345	BK602332	BK602317	BK602358	BK602311	BK1111-200216
							
200 A	BK602365	BK602345	BK602332	BK602328	BK602363	BK602311	BK1111-200216
							
300 A	BK602365	BK602353	BK602336	BK602320	BK602364	BK602311	BK1111-200216
							

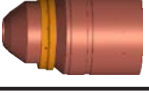
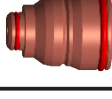
Aluminium
Plasma gas: Air
Shield gas: Nitrogen

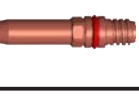
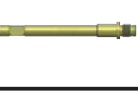
	External cover	Protective nozzle	Internal cover	Nozzle	Diffuser	Electrode	Immersion tube
30 A	BK602365	BK602340	BK602338	BK602312	BK602354	BK602300	BK1111-200216
							
80 A	BK602365	BK602342	BK602338	BK602314	BK602356	BK602301	BK1111-200216
							
140 A	BK602365	BK602343	BK602339	BK602315	BK602358	BK602309	BK1111-200216
							
170 A	BK602365	BK602348	BK602332	BK602316	BK602357	BK602302	BK1111-200216
							
200 A	BK602365	BK602345	BK602332	BK602317	BK602359	BK602304	BK1111-200216
							
300 A	BK602365	BK602346	BK602369	BK602319	BK602360	BK602305	BK1111-200216
							

9.4 Consumables for cutting with lubrication (optional APC)

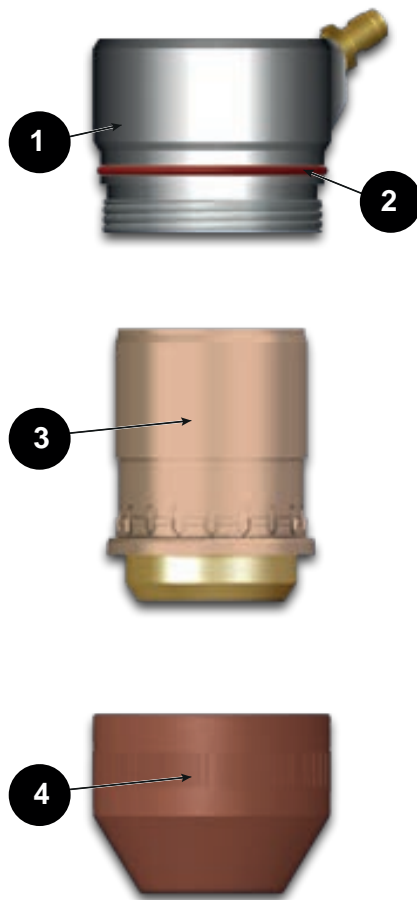











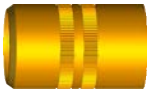





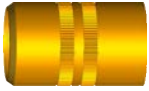



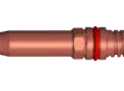





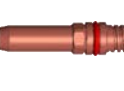

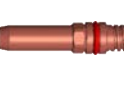

✓	normally held in stock.
✗	not in stock
	upon request.

Ref.	Part no	Stock	Order	Description
1	BK602640	✓		Drilling head body
2	BK1111-200322	✓		O-ring seal
3	BK602378	✓		External cover of drilling head
4	BK602376	✓		Drilling head protective nozzle (300A)
	BK602377	✓		Drilling head protective nozzle (80A-200A)

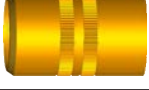
- While ordering parts, please indicate the quantity and note the number of your machine in the box above.

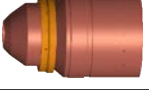

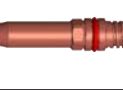











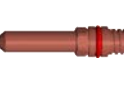





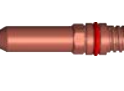









 Type <input type="text"/> Matricule <input type="text"/>	TYPE:
	Number:

Stainless steel
Plasma gas: Nitrogen
Shield gas: H₂O*

	External cover	Protective nozzle	Internal cover	Nozzle	Diffuser	Electrode	Immersion tube
80 A	BK602365	BK602342	BK602347	BK602325	BK602354	BK602310	BK1111-200216
							
140 A	BK602365	BK602352	BK602339	BK602327	BK602358	BK602311	BK1111-200216
							
170 A	BK602365	BK602345	BK602332	BK602317	BK602358	BK602311	BK1111-200216
							
200 A	BK602365	BK602345	BK602332	BK602328	BK602363	BK602311	BK1111-200216
							
300 A	BK602365	BK602353	BK602336	BK602320	BK602364	BK602311	BK1111-200216
							

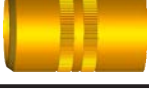
* Requires the use of the optional **Fineline** advanced process controller (APC)

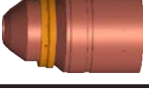
Aluminium
Plasma gas: Air
Shield gas: H₂O*

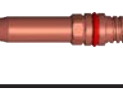
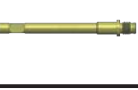
	External cover	Protective nozzle	Internal cover	Nozzle	Diffuser	Electrode	Immersion tube
80 A	BK602365	BK602342	BK602338	BK602314	BK602356	BK602301	BK1111-200216
							
140 A	BK602365	BK602343	BK602339	BK602315	BK602358	BK602309	BK1111-200216
							
170 A	BK602365	BK602348	BK602332	BK602316	BK602357	BK602302	BK1111-200216
							
200 A	BK602365	BK602345	BK602332	BK602328	BK602363	BK602304	BK1111-200216
							
300 A	BK602365	BK602346	BK602369	BK602319	BK602364	BK602305	BK1111-200216
							

* Requires the use of the optional **Fineline** advanced process controller (APC)

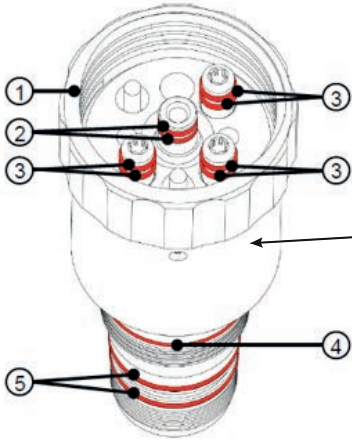

J

C

A



D



B

E

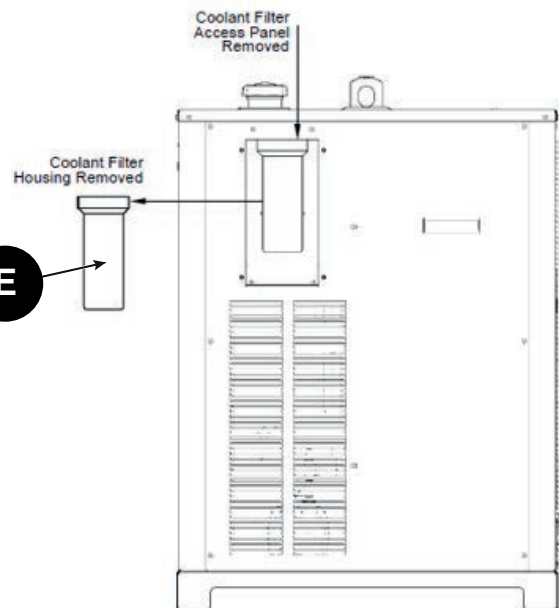

✓	normally held in stock.
✗	not in stock
	upon request.

Ref.	Part no	Stock	Order	Description
A	BK602625-2	✓		Magnum Pro Inox torch tip Quick disconnect
2	BK279112	✓		O-ring seal, 0.239 ID, 0.070 W Quantity per torch = 2
3	BK279113	✓		O-ring seal, 0.208 ID, 0.070 W Quantity per torch = 6
4	BK1111-200231	✓		O-ring seal, 1.260 ID X .050W Silicone 70A Quantity per torch = 1 (indicator, no sealing)
5	BK82014	✓		O-ring seal, Quantity per torch = 2
B	W000370707	✗		Case
	W000374324	✗		Slide
	AS-CW-04151100	✗		Fineline HD case for steel, 170A 30A (O2/O2) - 80A/140A/170A (O2/Air)
	AS-CW-04151101	✗		Fineline HD case for steel, 300A 30A (O2/O2) - 80A/140A/170A/200A/300A (O2/Air)
	AS-CW-04151102	✗		Fineline HD case for steel, air-N2, 170A 30A/80A/140A/170A (Air/N2)
	AS-CW-04151103	✗		Fineline HD case for steel, air-N2, 300A 30A/80A/140A/170A (Air/N2) 200A/300A (Air/N2)
	AS-CW-04151104	✗		Fineline HD case for steel, H17, H2O, 170A 30A/80A (Air/N2) 80A/140A/170A (H17/N2, N2/H2O)
	AS-CW-04151105	✗		Fineline HD case for steel, H17, H2O, 300A 30A/80A (Air/N2) 80A/140A/170A/200A/300A (H17/N2, N2/H2O)
	AS-CW-04151106	✗		Fineline HD case for aluminium, 170A 30A/80A/140A/170A (Air/N2, N2/H2O)
	AS-CW-04151107	✗		Fineline HD case for aluminium, 300A 30A/80A/140A/170A (Air/N2, N2/H2O) 200A/300A (Air/N2, N2/H2O)
C	BK602623	✓		Magnum Pro LC300m torch connector Quick disconnect
	BK716012	✓		O-ring seal lubricant, 5 gram tube
	BK716012-2	✓		O-ring seal lubricant, 56 gram tube, compatible with O2
	BK277086	✓		Screwdriver for removing the electrode
	BK602396	✓		Socket for removing the electrode (10mm, hexagonal, ¼ inch)
				Tool for removing the immersion tube. Standard 3/16" adjustable spanner
		W000373219	✓	
D	W000011092	✓		SprayMIG SVB: for spraying on the plate before cutting to avoid splatter and improve the quality of the holes.
E	KP4730-1	✓		Fineline coolant filter, (optional) APC water filter
J	BK27901	✓		O-ring seal, 1.625 ID, 0.125 W - indicator, no sealing

- While ordering parts, please indicate the quantity and note the number of your machine in the box above.

	TYPE:
	Number:

9.5 HPCIII process control assembly (main cabinet)

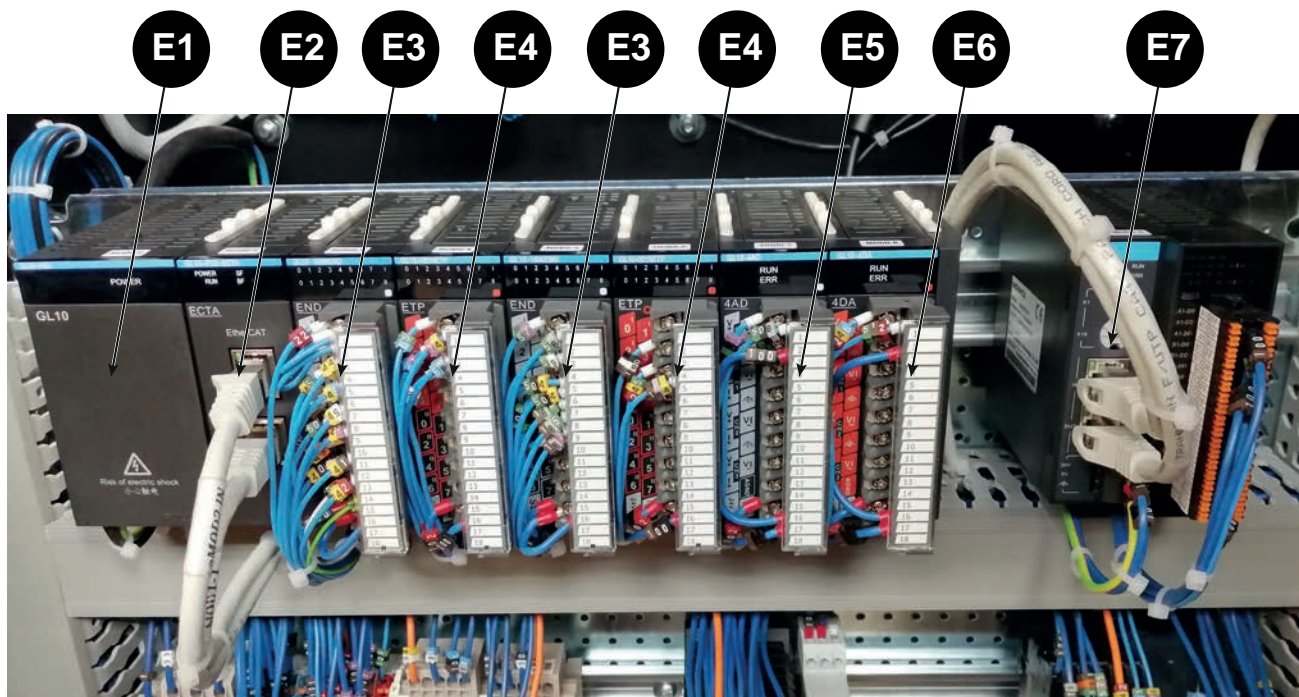

✓	normally held in stock.
✗	not in stock upon request.

Ref.	Part no	Stock	Order	Description
E1	AS-CS-C5703329	✓		GL10 power supply module
E2	AS-CS-C5703330	✓		GL10 EtherCAT module
E3	AS-CS-C5703324	✓		GL10 16 digital inputs module
E4	AS-CS-C5703325	✓		GL10 16 digital outputs module
E5	AS-CS-C5703326	✓		GL10 4 analogue inputs module
E6	AS-CS-C5703327	✓		GL10 4 analogue outputs module
E7	AS-CS-C5703328	✓		GL10 encoder module

• While ordering parts, please indicate the quantity and note the number of your machine in the box above.

CE Type <input type="text"/> Matricule <input type="text"/>	TYPE:
	Number:



E8

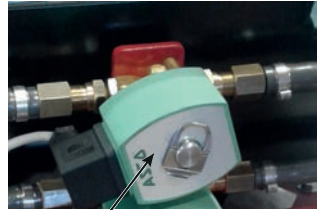

E11

E9

E10



✓	normally held in stock.
✗	not in stock upon request.

Ref.	Part no	Stock	Order	Description
E8	AS-CS-07087080			Fineline CPU PA9000 W10 (for NC versions before Windows 10)
E9	AS-CS-C5703997	✓		5-port Ethernet switch
E10	AS-CS-C5703664	✗		ADC repeater (used with large lengths of ADC bundles)
E11	AS-CS-5908124	✗		Optional coolant shutoff solenoid valve

- While ordering parts, please indicate the quantity and note the number of your machine in the box above.

Type <input style="width: 100px;" type="text"/> Matricule <input style="width: 100px;" type="text"/>	TYPE:
	Number:

