

POWERTEC® i250C, i320C STANDARD POWERTEC® i250C, i320C ADVANCED POWERTEC® i380C, i450C ADVANCED

Spare Parts	1
Figure A, B: Machine Assembly.....	2
Figure C, D, E, F: Inside Machine Assembly	8
Figure G: Wire Drive Assembly	9
Figure H: Front Assembly	10
Miscellaneous Items (not shown in figure A, B, C, D, E, F, G, H).....	11
Electrical Schematic.....	12
CODE: 50607, 50608	12
CODE: 50555, 50557, 50558	13
CODE: 50559	14
CODE: 50634, 50635, 50648, 50649, 50650, 50651.....	15



Spare Parts

SP50607, SP50555, SP50608, SP50557, SP50558, SP50559, SP50634, SP50648, SP50635, SP50649, SP50650, SP50651 REV04
11/2024

ASSEMBLY PAGE NAME			Machine Assembly	Machine Assembly	Inside Machine Assembly	Inside Machine Assembly	Inside Machine Assembly	Inside Machine Assembly	Wire Drive Assembly	Front Assembly	Miscellaneous Items
CODE NO.:	K NO.:	FIGURE NO.:	A	B	C	D	E	F	G	H	-
50607	K14284-1	POWERTEC® i250C STANDARD	1	-	1	-	-	-	1	1	1
50634		50634	-	2	-	-	2	-	2	2	2
50555	K14285-1	POWERTEC® i250C ADVANCED	3	-	3	-	-	-	3	3	3
50648		50648	-	4	-	-	4	-	4	4	4
50608	K14286-1	POWERTEC® i320C STANDARD	5	-	5	-	-	-	5	5	5
50635		50635	-	6	-	-	6	-	6	6	6
50557	K14287-1	POWERTEC® i320C ADVANCED	7	-	7	-	-	-	7	7	7
50649		50649	-	8	-	-	8	-	8	8	8
50558	K14288-1	POWERTEC® i380C ADVANCED	9	-	9	-	-	-	9	9	9
50650		50650	-	10	-	-	-	10	10	10	10
50559	K14289-1	POWERTEC® i450C ADVANCED	11	-	-	11	-	-	11	11	11
50651		50651	-	12	-	-	-	12	12	12	12

*items highlighted in bold are recommended spare parts

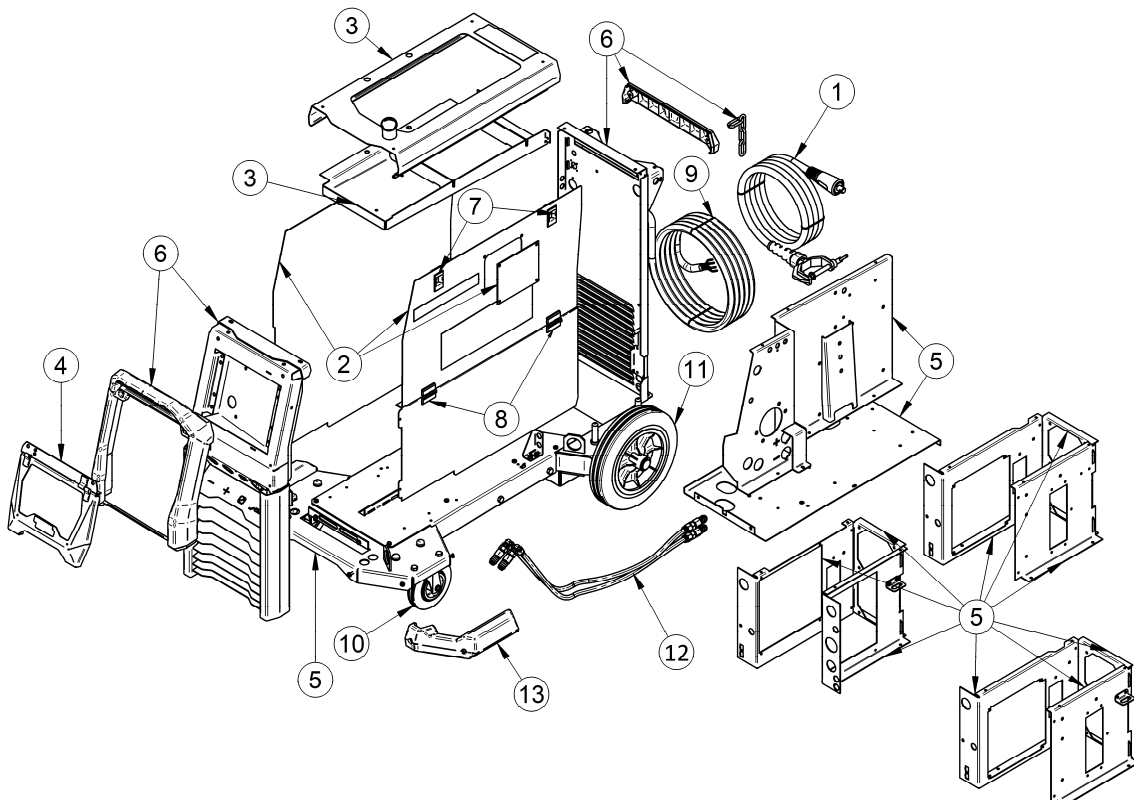

Figure A

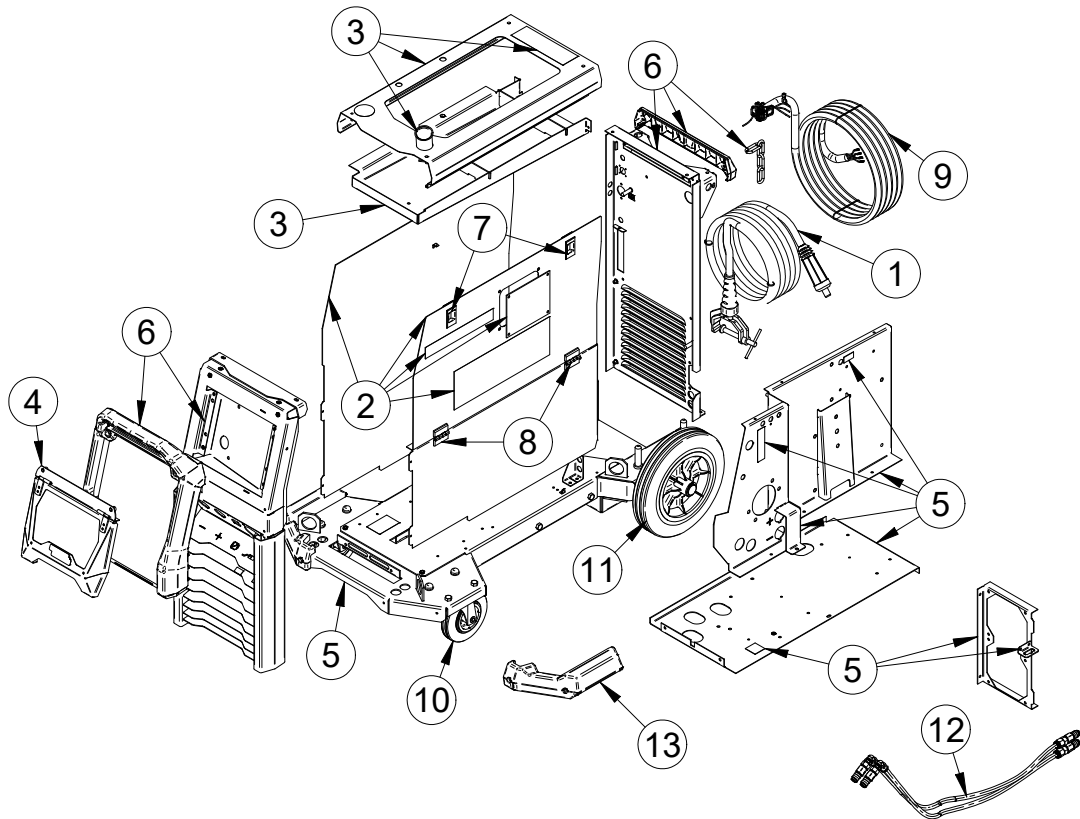

Figure B

Figure A, B: Machine Assembly

Item	Description	Part Number	QTY	1	2	3	4	5	6	7	8	9	10	11	12
1	WELDING CABLE	D-5578-176-4R	1	X	X	X	X	X	X	X	X				
	WELDING CABLE	R-5041-024-1R	1									X	X		
	WELDING CABLE	R-5041-024-2R	1											X	X
2	SIDE PANEL KIT includes:	T-8040-077-1R	1	X	X	X	X	X	X	X	X	X	X	X	X
	LEFT SIDE PANEL		1	X	X	X	X	X	X	X	X	X	X	X	X
	UPPER SIDE PANEL		1	X	X	X	X	X	X	X	X	X	X	X	X
	BOTTOM SIDE PANEL		1	X	X	X	X	X	X	X	X	X	X	X	X
	PLATE		1	X	X	X	X	X	X	X	X	X	X	X	X
	LABEL - ROLLS COLOURS		1	X	X	X	X	X	X	X	X	X	X	X	X
	LABEL - POWERTEC®		2	X	X	X	X	X	X	X	X	X	X	X	X
	LABEL - LINCOLN ELECTRIC		2	X	X	X	X	X	X	X	X	X	X	X	X
3	COVER KIT includes:	T-8040-078-1R	1	X	X	X	X	X	X	X	X	X	X	X	
	COVER		1	X	X	X	X	X	X	X	X	X	X	X	
	SHELF		1	X	X	X	X	X	X	X	X	X	X	X	
	WARNING LABEL		1	X	X	X	X	X	X	X	X	X	X	X	
4	CONTROL PANEL COVER	T-8040-079-1R	1									X	X	X	
5	BASE, PARTITION, SHELF KIT includes:	T-8040-080-1R	1	X		X		X		X					
	BASE ASSEMBLY		1	X		X		X		X					
	PARTITION ASSEMBLY		1	X		X		X		X					
	USB LABEL		1	X		X		X		X					
	WARNING LABEL		1	X		X		X		X					
	SHELF		1	X		X		X		X					
	FUSE LABEL		1	X		X		X		X					
	BRACKET		1	X		X		X		X					

5	BASE, PARTITION, SHELF KIT includes:	T-8040-091-1R	1										X				
	BASE ASSEMBLY		1											X			
	PARTITION ASSEMBLY		1											X			
	USB LABEL		1											X			
	WARNING LABEL		1											X			
	SHELF		1											X			
	FUSE LABEL		1											X			
	BRACKET		1											X			
5	BASE, PARTITION, SHELF KIT includes:	T-8040-081-1R	1													X	
	BASE ASSEMBLY		1													X	
	PARTITION ASSEMBLY		1													X	
	USB LABEL		1													X	
	WARNING LABEL		1													X	
	SHELF		1													X	
	FUSE LABEL		1													X	
	BRACKET		1													X	
5	BASE, PARTITION, SHELF KIT includes:	T-8040-175-1R	1		X	X	X	X									
	BASE ASSEMBLY		1		X	X	X	X									
	PARTITION ASSEMBLY		1		X	X	X	X									
	USB LABEL		1		X	X	X	X									
	WARNING LABEL		1		X	X	X	X									
	SHELF		1		X	X	X	X									
	FUSE LABEL		1		X	X	X	X									
	BRACKET		1		X	X	X	X									
	PARTITION		1		X	X	X	X									
	BRACKET		1		X	X	X	X									
	5		BASE, PARTITION, SHELF KIT includes:	T-8040-175-2R	1										X	X	
BASE ASSEMBLY		1											X	X			
PARTITION ASSEMBLY		1											X	X			
USB LABEL		1											X	X			
WARNING LABEL		1											X	X			
SHELF		1											X	X			
FUSE LABEL		1											X	X			
BRACKET		1											X	X			
PARTITION		1											X	X			
BRACKET		1											X	X			
BRACKET		1											X	X			
6	FRONT AND REAR PANEL KIT:	T-8040-082-1R	1	X	X	X	X										
	FRONT PANEL ASSEMBLY		1	X	X	X	X										
	REAR PANEL ASSEMBLY		1	X	X	X	X										
	FRONT HANDLE COMPLETE		1	X	X	X	X										
	BACK PANEL		1	X	X	X	X										
	COVER		1	X	X	X	X										
	GAS LABEL		1	X	X	X	X										
	CHAIN		1	X	X	X	X										

6	FRONT AND REAR PANEL KIT:	T-8040-083-1R	1										X			
	FRONT PANEL ASSEMBLY		1											X		
	REAR PANEL ASSEMBLY		1											X		
	FRONT HANDLE COMPLETE		1											X		
	IN LABEL		1											X		
	OUT LABEL		1											X		
	IN/OUT LABEL		1											X		
	BACK PANEL		1											X		
	COVER		1											X		
	GAS LABEL		1											X		
	CHAIN		1											X		
	6		FRONT AND REAR PANEL KIT:	T-8040-092-1R	1											
FRONT PANEL ASSEMBLY		1													X	
REAR PANEL ASSEMBLY		1													X	
FRONT HANDLE COMPLETE		1													X	
IN LABEL		1													X	
OUT LABEL		1													X	
IN/OUT LABEL		1													X	
BACK PANEL		1													X	
COVER		1													X	
GAS LABEL		1													X	
CHAIN		1													X	
6		FRONT AND REAR PANEL KIT:	T-8040-176-1R		1	X	X	X	X	X						
	FRONT PANEL ASSEMBLY	1		X	X	X	X	X								
	REAR PANEL ASSEMBLY	1		X	X	X	X	X								
	FRONT HANDLE COMPLETE	1		X	X	X	X	X								
	BACK PANEL	1		X	X	X	X	X								
	COVER	1		X	X	X	X	X								
	GAS LABEL	1		X	X	X	X	X								
	CHAIN	1		X	X	X	X	X								
	COVER	1		X	X	X	X	X								
	HOLE PLUG	1		X	X	X	X	X								
	CAP	1		X	X	X	X	X								
	RUBBER STOPPER	1		X	X	X	X	X								
6	FRONT AND REAR PANEL KIT:	T-8040-176-2R	1										X	X		
	FRONT PANEL ASSEMBLY		1										X	X		
	REAR PANEL ASSEMBLY		1										X	X		
	FRONT HANDLE COMPLETE		1										X	X		
	IN LABEL		1										X	X		
	OUT LABEL		1										X	X		
	IN/OUT LABEL		1										X	X		
	BACK PANEL		1										X	X		
	COVER		1										X	X		
	GAS LABEL		1										X	X		
	CHAIN		1										X	X		
	HOLE PLUG		1										X	X		
	CAP		1										X	X		
	RUBBER STOPPER		1										X	X		
7	LOCK	0654-610-004R	2	X	X	X	X	X	X	X	X	X	X	X		

8	LEAF HINGE	0654-610-007R	2	X	X	X	X	X	X	X	X	X	X	X	X
9	MAIN INPUT CORD	R-5041-497-1R	1	X		X		X		X		X			
	MAIN INPUT CORD	R-5041-497-2R	1											X	
	MAIN INPUT CORD	R-5041-654-2R	1		X		X		X		X		X		
	MAIN INPUT CORD	R-5041-654-1R	1												X
10	TURNING WHEEL DIA-125	1029-660-127R	2	X	X	X	X	X	X	X	X	X	X	X	X
11	WHEEL DIA-250	1029-660-250R	2	X	X	X	X	X	X	X	X	X	X	X	X
12	WATER CONNECTION KIT:	T-8040-084-1R	1									X	X	X	X
	COOLING HOSES		2									X	X	X	X
	COUPLING RECTUS		4									X	X	X	X
	THREAD ADAPTER		4									X	X	X	X
	ORIENTING ELBOW MALE ADAPTOR		2									X	X	X	X
	STRAIGHT MALE ADAPTOR		2									X	X	X	X
13	BUMPER KIT	T-8040-047-1R	1									X	X	X	X

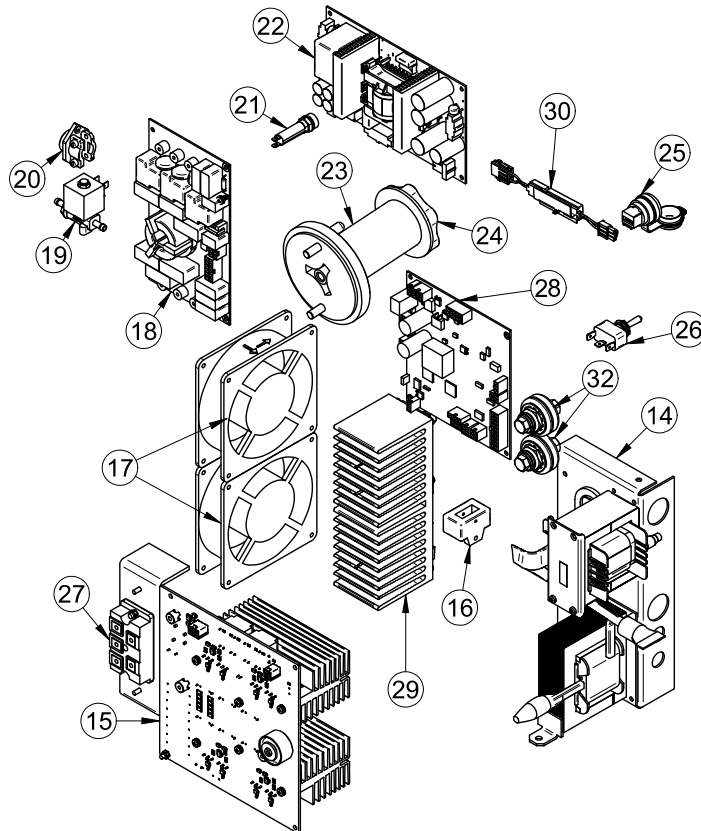

Figure C

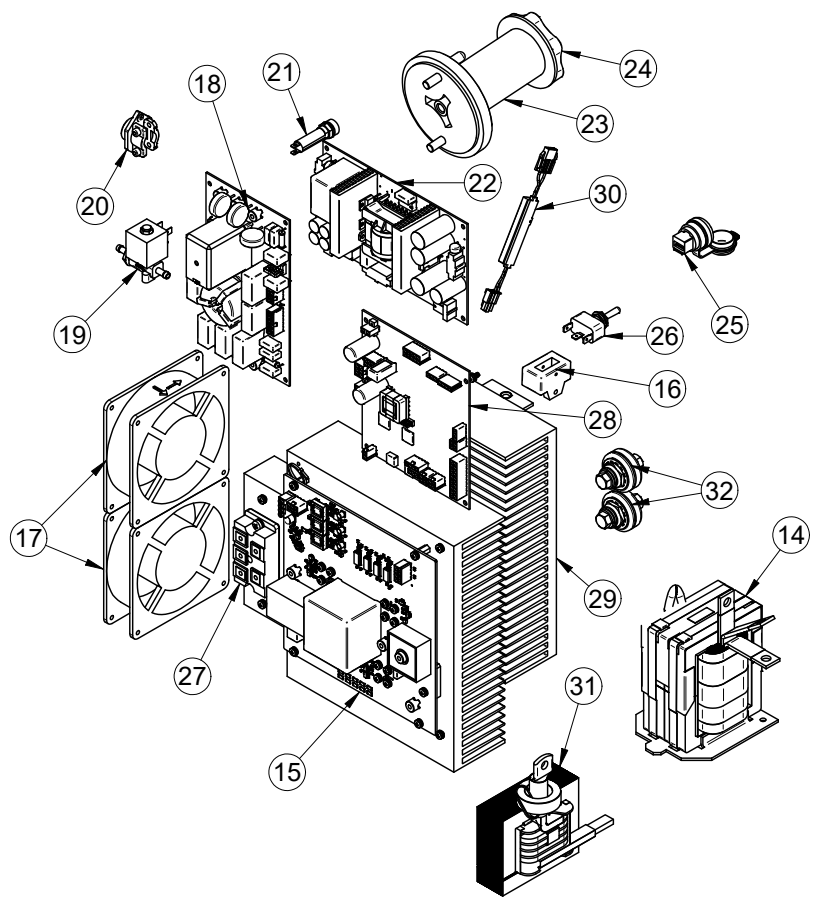

Figure D

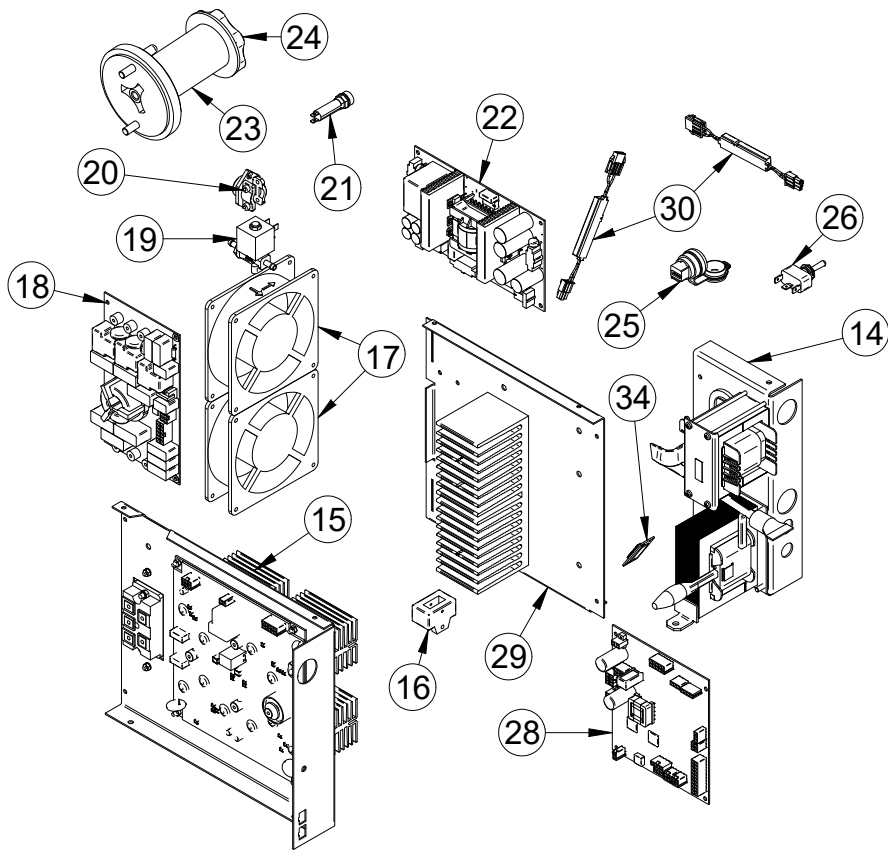

Figure E

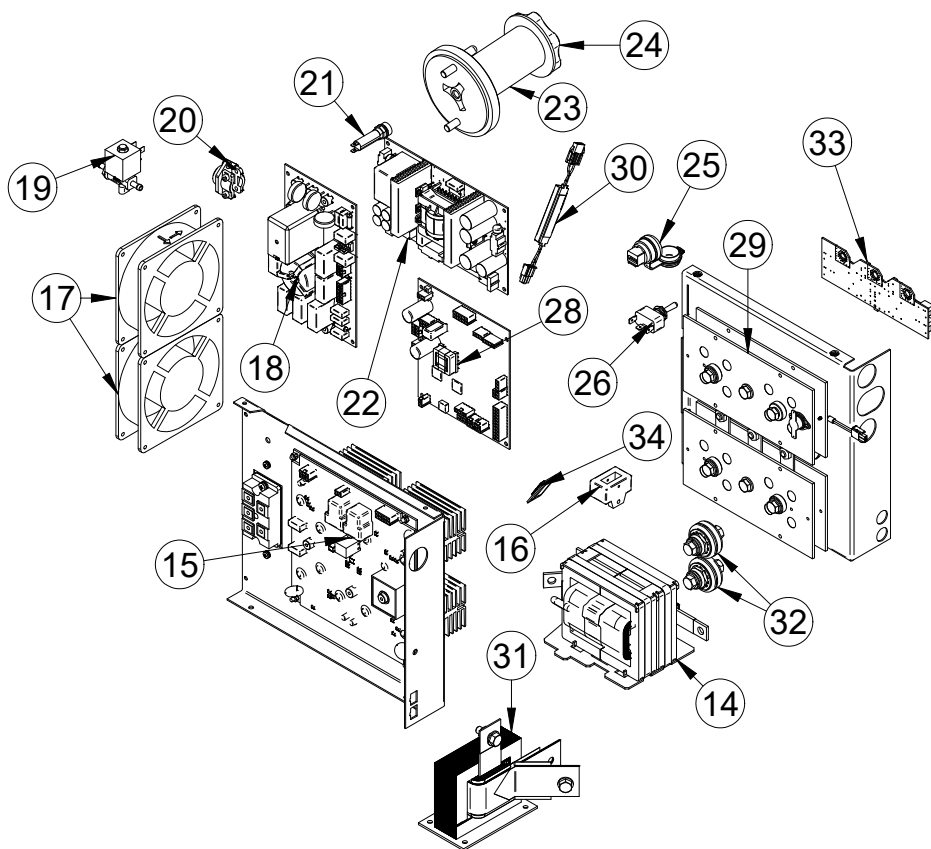

Figure F

Figure C, D, E, F: Inside Machine Assembly

Item	Description	Part Number	QTY	1	2	3	4	5	6	7	8	9	10	11	12
14	TRANSFORMER AND CHOKE	R-8040-420-1R	1	X	X	X	X	X	X	X	X	X			
	TRANSFORMER	R-4034-175-2R	1											X	
	TRANSFORMER	R-4034-182-1R	1										X		X
15	INVERTER BOARD	R-6042-079-1R	1	X		X		X		X		X			
	INVERTER BOARD	T-8040-022-1R	1											X	
	INVERTER BOARD ASSEMBLY	R-8040-508-1R	1												X
	INVERTER BOARD ASSEMBLY	R-8040-508-2R	1		X		X		X		X		X		
16	HALL SENSOR	W4900004R	1	X	X	X	X	X	X	X	X	X	X	X	X
17	FAN	W66X1369R	2	X	X	X	X	X	X	X	X		X	X	X
	FAN	R-8040-433-1R	2									X			
18	INPUT FILTER	Y051-1R	1	X	X	X	X	X	X	X	X	X	X		
	INPUT FILTER	Y056-1R	1											X	X
19	GAS SOLENOID ELRA 5536NB2	0972-423-040R	1	X	X	X	X	X	X	X	X	X	X	X	X
20	CABLE RELIEF	1361-599-674R	1	X	X	X	X	X	X	X	X	X	X	X	X
21	FUSE SOCKET	1158-632-032R	1	X	X	X	X	X	X	X	X	X	X	X	X
	FUSE 1A 400V	1158-660-010R	1	X	X	X	X	X	X	X	X				
	FUSE 2A 400V	1158-660-003R	1									X	X	X	X
22	SUPPLY PC BOARD	R-6042-081-1R	1	X	X	X	X	X	X	X	X	X	X	X	X
23	WIRE SPOOL HUB	0744-000-335R	1	X	X	X	X	X	X	X	X	X	X	X	X
24	PLASTIC NUT	0744-000-336R	1	X	X	X	X	X	X	X	X	X	X	X	X
25	USB SOCKET	1158-641-061R	1			X	X			X	X	X	X	X	X
26	SWITCH	1115-280-004R	1	X	X	X	X	X	X	X	X	X	X	X	X
27	THREE PHASE BRIDGE	W4100021R	1	X	X	X	X	X	X						
28	CONTROL BOARD	R-6042-080-1R	1							X					
	CONTROL BOARD	R-6042-080-2R	1					X							
	CONTROL BOARD	R-6042-082-1R	1			X									
	CONTROL BOARD	R-6042-082-2R	1	X											
	CONTROL BOARD	R-6042-087-1R	1									X			
	CONTROL BOARD	R-6042-089-1R	1											X	
	CONTROL BOARD	R-6042-117-1R	1				X								
	CONTROL BOARD	R-6042-117-2R	1		X										
	CONTROL BOARD	R-6042-118-1R	1								X				
	CONTROL BOARD	R-6042-118-2R	1						X						
	CONTROL BOARD	R-6042-119-2R	1										X		
29	OUTPUT BRIDGE	R-8040-388-1R	1	X		X		X		X		X			
	OUTPUT BRIDGE	T-8040-023-1R	1											X	
	OUTPUT BRIDGE	R-8040-453-2R	1		X		X		X		X				
	OUTPUT BRIDGE	R-8040-499-1R	1												X
	OUTPUT BRIDGE	R-8040-499-2R	1										X		
30	LED MODULE	R-5041-508-1R	2	X	X	X	X	X	X	X	X	X	X	X	X
31	CHOKE	R-8040-441-1R	1											X	
	CHOKE	R-8040-513-1R	1											X	X
32	SOCKET ASSEMBLY	T-8040-085-1R	2									X	X	X	X
33	OUTPUT AND FILTER BOARD (PTi)	Y087-1R	1										X		X
34	OUTPUT EMC-FILTER	Y097-1R	1		X		X		X		X		X		X

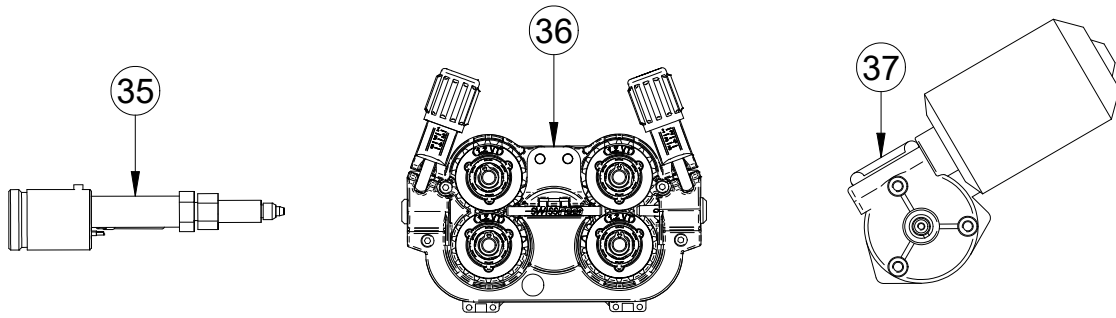

Figure G

Figure G: Wire Drive Assembly

Item	Description	Part Number	QTY	1	2	3	4	5	6	7	8	9	10	11	12
35	EURO SOCKET	R-8040-389-1R	1	X	X	X	X	X	X	X	X	X	X		
	EURO SOCKET	T-8040-021-1R	1											X	X
36	COMPLETE FEED PLATE ASSEMBLY (INCLUDES 1.0/1.2 MM DRIVE ROLLS AND WIRE GUIDE KIT)	0744-000-009R	1	X	X	X	X	X	X	X	X	X	X	X	X
37	WIRE DRIVE MOTOR	1111-722-048R	1	X	X	X	X	X	X	X	X	X	X	X	X

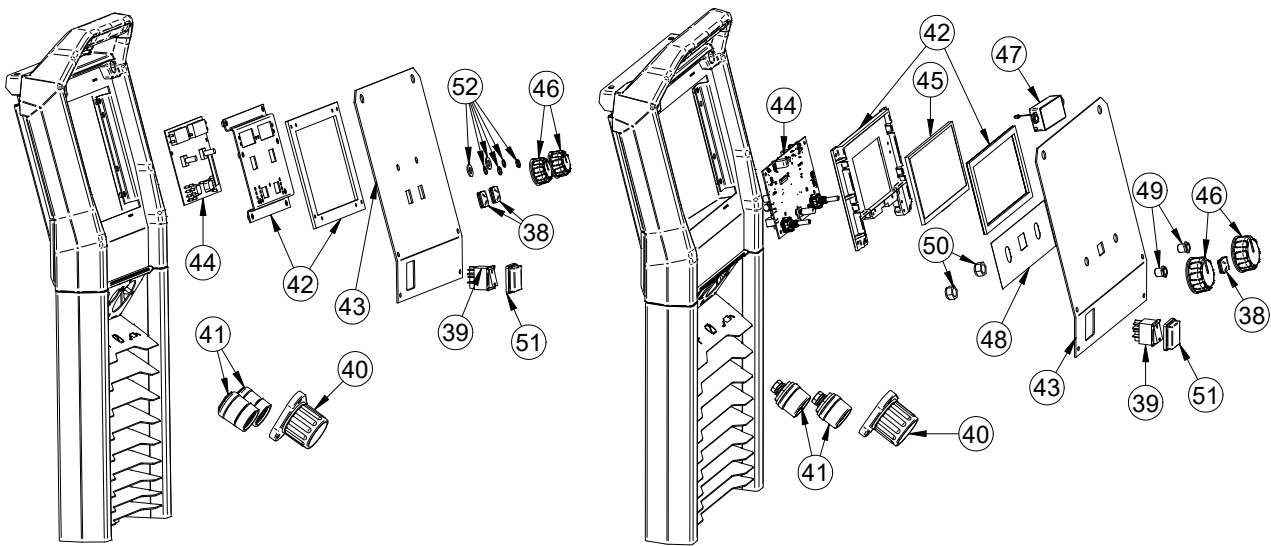

Figure H

Figure H: Front Assembly

Item	Description	Part Number	QTY	1	2	3	4	5	6	7	8	9	10	11	12
38	BUTTON	9SS23055	1	X	X	X	X	X	X	X	X				
	BUTTON	9SS23055	2	X	X			X	X						
39	MAIN SWITCH	1115-270-022R	1	X	X	X	X	X	X	X	X	X	X	X	X
40	EURO SLEEVE	C-1891-006-1R	1	X	X	X	X	X	X	X	X	X	X	X	X
41	SOCKET	2EINN0500FR	2	X	X	X	X	X	X	X	X	X	X		
	SOCKET	90000595PR	2											X	X
42	DISPLAY KIT includes:	T-8040-089-1R	1	X	X			X	X						
	BRACKET		1	X	X			X	X						
	BRACKET		1	X	X			X	X						
42	DISPLAY KIT includes:	T-8040-090-1R	1			X	X			X	X	X	X	X	X
	FRAME		1			X	X			X	X	X	X	X	X
	GASKET		1			X	X			X	X	X	X	X	X
43	FRONT PANEL	R-0000-245-1R	1	X	X										
	FRONT PANEL	R-0000-245-2R	1					X	X						
	FRONT PANEL	R-0000-246-1R	1			X	X								
	FRONT PANEL	R-0000-246-2R	1							X	X				
	FRONT PANEL	R-0000-246-3R	1									X	X		
	FRONT PANEL	R-0000-246-4R	1											X	X
44	USER INTERFACE PCB	R-6042-078-1R	1	X				X							
	USER INTERFACE PCB	R-6042-116-1R	1		X				X						
	USER INTERFACE PCB	Y063-1TR	1			X	X			X	X	X	X	X	X
45	LCD	0942-177-002R	1			X	X			X	X	X	X	X	X
46	KNOB	9SM22778-2	2	X	X			X	X						
	KNOB	9SM22778-3	2			X	X			X	X	X	X	X	X
47	SPEAKER	0943-719-016R	1			X	X			X	X	X	X	X	X
48	COPPER LABEL	R-0000-341-1R	1			X	X			X	X	X	X	X	X
49	PIPE	R-2013-267-1R	2			X	X			X	X	X	X	X	X
50	ENCODER REDUCTION	R-2013-240-1R	2			X	X			X	X	X	X	X	X
51	SWITCH COVER AND BEZEL	1115-299-073R	1	X	X	X	X	X	X	X	X	X	X	X	X
52	SCREW SET	T-8040-177-1R	1	X	X			X	X						

Miscellaneous Items (not shown in figure A, B, C, D, E, F, G, H)

Item	Description	Part Number	QTY	1	2	3	4	5	6	7	8	9	10	11	12
53	HARNESSES KIT	T-8040-086-1R	1	X		X		X		X					
54	HARNESSES KIT	T-8040-087-1R	1									X			
55	HARNESSES KIT	T-8040-088-1R	1											X	
56	HARNESSES KIT	T-8040-180-1R	1		X		X		X		X				
57	HARNESSES KIT	T-8040-180-2R	1										X		
58	HARNESSES KIT	T-8040-180-3R	1												X

