

# Operator's Manual

# *AutoDrive*<sup>®</sup> 4R220

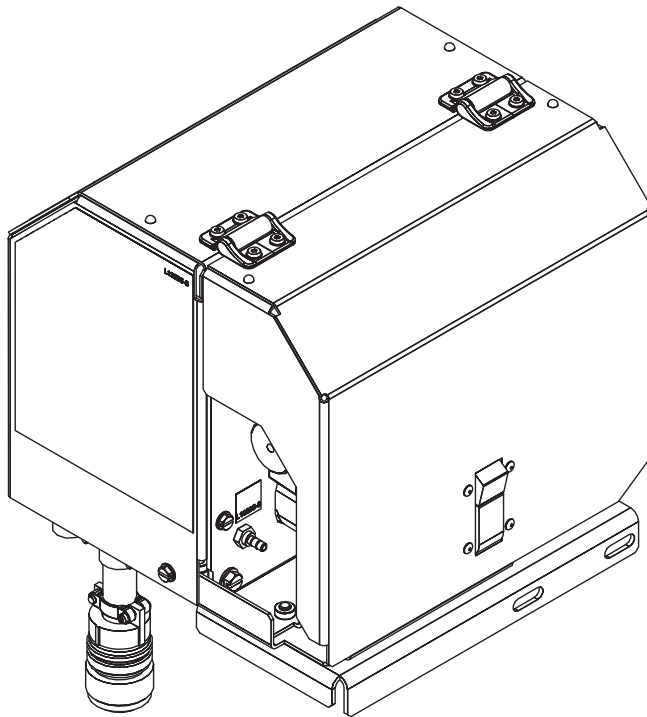

For use with machines having Code Numbers:  
**12417**



**Register your machine:**  
[www.lincolnelectric.com/register](http://www.lincolnelectric.com/register)

**Authorized Service and Distributor Locator:**  
[www.lincolnelectric.com/locator](http://www.lincolnelectric.com/locator)

**Save for future reference**

Date Purchased

Code: (ex: 10859)

Serial: (ex: U1060512345)

# THANK YOU FOR SELECTING A QUALITY PRODUCT BY LINCOLN ELECTRIC.

## PLEASE EXAMINE CARTON AND EQUIPMENT FOR DAMAGE IMMEDIATELY

When this equipment is shipped, title passes to the purchaser upon receipt by the carrier. Consequently, claims for material damaged in shipment must be made by the purchaser against the transportation company at the time the shipment is received.

## SAFETY DEPENDS ON YOU

Lincoln arc welding and cutting equipment is designed and built with safety in mind. However, your overall safety can be increased by proper installation ... and thoughtful operation on your part. **DO NOT INSTALL, OPERATE OR REPAIR THIS EQUIPMENT WITHOUT READING THIS MANUAL AND THE SAFETY PRECAUTIONS CONTAINED THROUGHOUT.** And, most importantly, think before you act and be careful.

### **WARNING**

This statement appears where the information must be followed exactly to avoid serious personal injury or loss of life.

### **CAUTION**

This statement appears where the information must be followed to avoid minor personal injury or damage to this equipment.



## KEEP YOUR HEAD OUT OF THE FUMES.

**DON'T** get too close to the arc. Use corrective lenses if necessary to stay a reasonable distance away from the arc.

**READ** and obey the Safety Data Sheet (SDS) and the warning label that appears on all containers of welding materials.

**USE ENOUGH VENTILATION** or exhaust at the arc, or both, to keep the fumes and gases from your breathing zone and the general area.

**IN A LARGE ROOM OR OUTDOORS**, natural ventilation may be adequate if you keep your head out of the fumes (See below).

**USE NATURAL DRAFTS** or fans to keep the fumes away from your face.

If you develop unusual symptoms, see your supervisor. Perhaps the welding atmosphere and ventilation system should be checked.



## WEAR CORRECT EYE, EAR & BODY PROTECTION

**PROTECT** your eyes and face with welding helmet properly fitted and with proper grade of filter plate (See ANSI Z49.1).

**PROTECT** your body from welding spatter and arc flash with protective clothing including woolen clothing, flame-proof apron and gloves, leather leggings, and high boots.

**PROTECT** others from splatter, flash, and glare with protective screens or barriers.

**IN SOME AREAS**, protection from noise may be appropriate.

**BE SURE** protective equipment is in good condition.

Also, wear safety glasses in work area **AT ALL TIMES.**



## SPECIAL SITUATIONS

**DO NOT WELD OR CUT** containers or materials which previously had been in contact with hazardous substances unless they are properly cleaned. This is extremely dangerous.

**DO NOT WELD OR CUT** painted or plated parts unless special precautions with ventilation have been taken. They can release highly toxic fumes or gases.

## Additional precautionary measures

**PROTECT** compressed gas cylinders from excessive heat, mechanical shocks, and arcs; fasten cylinders so they cannot fall.

**BE SURE** cylinders are never grounded or part of an electrical circuit.

**REMOVE** all potential fire hazards from welding area.

**ALWAYS HAVE FIRE FIGHTING EQUIPMENT READY FOR IMMEDIATE USE AND KNOW HOW TO USE IT.**



## SECTION A: WARNINGS



### CALIFORNIA PROPOSITION 65 WARNINGS



**WARNING:** Breathing diesel engine exhaust exposes you to chemicals known to the State of California to cause cancer and birth defects, or other reproductive harm.

- Always start and operate the engine in a well-ventilated area.
- If in an exposed area, vent the exhaust to the outside.
- Do not modify or tamper with the exhaust system.
- Do not idle the engine except as necessary.

For more information go to [www.P65warnings.ca.gov/diesel](http://www.P65warnings.ca.gov/diesel)

**WARNING:** This product, when used for welding or cutting, produces fumes or gases which contain chemicals known to the State of California to cause birth defects and, in some cases, cancer. (California Health & Safety Code § 25249.5 *et seq.*)



**WARNING:** Cancer and Reproductive Harm  
[www.P65warnings.ca.gov](http://www.P65warnings.ca.gov)

**ARC WELDING CAN BE HAZARDOUS. PROTECT YOURSELF AND OTHERS FROM POSSIBLE SERIOUS INJURY OR DEATH. KEEP CHILDREN AWAY. PACEMAKER WEARERS SHOULD CONSULT WITH THEIR DOCTOR BEFORE OPERATING.**

Read and understand the following safety highlights. For additional safety information, it is strongly recommended that you purchase a copy of "Safety in Welding & Cutting - ANSI Standard Z49.1" from the American Welding Society, P.O. Box 351040, Miami, Florida 33135 or CSA Standard W117.2-1974. A Free copy of "Arc Welding Safety" booklet E205 is available from the Lincoln Electric Company, 22801 St. Clair Avenue, Cleveland, Ohio 44117-1199.

**BE SURE THAT ALL INSTALLATION, OPERATION, MAINTENANCE AND REPAIR PROCEDURES ARE PERFORMED ONLY BY QUALIFIED INDIVIDUALS.**



### FOR ENGINE POWERED EQUIPMENT.

- 1.a. Turn the engine off before troubleshooting and maintenance work unless the maintenance work requires it to be running.
- 1.b. Operate engines in open, well-ventilated areas or vent the engine exhaust fumes outdoors.
- 1.c. Do not add the fuel near an open flame welding arc or when the engine is running. Stop the engine and allow it to cool before refueling to prevent spilled fuel from vaporizing on contact



with hot engine parts and igniting. Do not spill fuel when filling tank. If fuel is spilled, wipe it up and do not start engine until fumes have been eliminated.

- 1.d. Keep all equipment safety guards, covers and devices in position and in good repair. Keep hands, hair, clothing and tools away from V-belts, gears, fans and all other moving parts when starting, operating or repairing equipment.
- 1.e. In some cases it may be necessary to remove safety guards to perform required maintenance. Remove guards only when necessary and replace them when the maintenance requiring their removal is complete. Always use the greatest care when working near moving parts.
- 1.f. Do not put your hands near the engine fan. Do not attempt to override the governor or idler by pushing on the throttle control rods while the engine is running.
- 1.g. To prevent accidentally starting gasoline engines while turning the engine or welding generator during maintenance work, disconnect the spark plug wires, distributor cap or magneto wire as appropriate.
- 1.h. To avoid scalding, do not remove the radiator pressure cap when the engine is hot.



### ELECTRIC AND MAGNETIC FIELDS MAY BE DANGEROUS



- 2.a. Electric current flowing through any conductor causes localized Electric and Magnetic Fields (EMF). Welding current creates EMF fields around welding cables and welding machines
- 2.b. EMF fields may interfere with some pacemakers, and welders having a pacemaker should consult their physician before welding.
- 2.c. Exposure to EMF fields in welding may have other health effects which are now not known.
- 2.d. All welders should use the following procedures in order to minimize exposure to EMF fields from the welding circuit:
  - 2.d.1. Route the electrode and work cables together - Secure them with tape when possible.
  - 2.d.2. Never coil the electrode lead around your body.
  - 2.d.3. Do not place your body between the electrode and work cables. If the electrode cable is on your right side, the work cable should also be on your right side.
  - 2.d.4. Connect the work cable to the workpiece as close as possible to the area being welded.
  - 2.d.5. Do not work next to welding power source.



## ELECTRIC SHOCK CAN KILL.



- 3.a. The electrode and work (or ground) circuits are electrically “hot” when the welder is on. Do not touch these “hot” parts with your bare skin or wet clothing. Wear dry, hole-free gloves to insulate hands.
- 3.b. Insulate yourself from work and ground using dry insulation. Make certain the insulation is large enough to cover your full area of physical contact with work and ground.

**In addition to the normal safety precautions, if welding must be performed under electrically hazardous conditions (in damp locations or while wearing wet clothing; on metal structures such as floors, gratings or scaffolds; when in cramped positions such as sitting, kneeling or lying, if there is a high risk of unavoidable or accidental contact with the workpiece or ground) use the following equipment:**

- Semiautomatic DC Constant Voltage (Wire) Welder.
  - DC Manual (Stick) Welder.
  - AC Welder with Reduced Voltage Control.
- 3.c. In semiautomatic or automatic wire welding, the electrode, electrode reel, welding head, nozzle or semiautomatic welding gun are also electrically “hot”.
  - 3.d. Always be sure the work cable makes a good electrical connection with the metal being welded. The connection should be as close as possible to the area being welded.
  - 3.e. Ground the work or metal to be welded to a good electrical (earth) ground.
  - 3.f. Maintain the electrode holder, work clamp, welding cable and welding machine in good, safe operating condition. Replace damaged insulation.
  - 3.g. Never dip the electrode in water for cooling.
  - 3.h. Never simultaneously touch electrically “hot” parts of electrode holders connected to two welders because voltage between the two can be the total of the open circuit voltage of both welders.
  - 3.i. When working above floor level, use a safety belt to protect yourself from a fall should you get a shock.
  - 3.j. Also see Items 6.c. and 8.



## ARC RAYS CAN BURN.



- 4.a. Use a shield with the proper filter and cover plates to protect your eyes from sparks and the rays of the arc when welding or observing open arc welding. Headshield and filter lens should conform to ANSI Z87.1 standards.
- 4.b. Use suitable clothing made from durable flame-resistant material to protect your skin and that of your helpers from the arc rays.
- 4.c. Protect other nearby personnel with suitable, non-flammable screening and/or warn them not to watch the arc nor expose themselves to the arc rays or to hot spatter or metal.



## FUMES AND GASES CAN BE DANGEROUS.



- 5.a. Welding may produce fumes and gases hazardous to health. Avoid breathing these fumes and gases. When welding, keep your head out of the fume. Use enough ventilation and/or exhaust at the arc to keep fumes and gases away from the breathing zone. **When welding hardfacing (see instructions on container or SDS) or on lead or cadmium plated steel and other metals or coatings which produce highly toxic fumes, keep exposure as low as possible and within applicable OSHA PEL and ACGIH TLV limits using local exhaust or mechanical ventilation unless exposure assessments indicate otherwise. In confined spaces or in some circumstances, outdoors, a respirator may also be required. Additional precautions are also required when welding on galvanized steel.**
- 5.b. The operation of welding fume control equipment is affected by various factors including proper use and positioning of the equipment, maintenance of the equipment and the specific welding procedure and application involved. Worker exposure level should be checked upon installation and periodically thereafter to be certain it is within applicable OSHA PEL and ACGIH TLV limits.
- 5.c. Do not weld in locations near chlorinated hydrocarbon vapors coming from degreasing, cleaning or spraying operations. The heat and rays of the arc can react with solvent vapors to form phosgene, a highly toxic gas, and other irritating products.
- 5.d. Shielding gases used for arc welding can displace air and cause injury or death. Always use enough ventilation, especially in confined areas, to insure breathing air is safe.
- 5.e. Read and understand the manufacturer’s instructions for this equipment and the consumables to be used, including the Safety Data Sheet (SDS) and follow your employer’s safety practices. SDS forms are available from your welding distributor or from the manufacturer.
- 5.f. Also see item 1.b.



## WELDING AND CUTTING SPARKS CAN CAUSE FIRE OR EXPLOSION.



- 6.a. Remove fire hazards from the welding area. If this is not possible, cover them to prevent the welding sparks from starting a fire. Remember that welding sparks and hot materials from welding can easily go through small cracks and openings to adjacent areas. Avoid welding near hydraulic lines. Have a fire extinguisher readily available.
- 6.b. Where compressed gases are to be used at the job site, special precautions should be used to prevent hazardous situations. Refer to "Safety in Welding and Cutting" (ANSI Standard Z49.1) and the operating information for the equipment being used.
- 6.c. When not welding, make certain no part of the electrode circuit is touching the work or ground. Accidental contact can cause overheating and create a fire hazard.
- 6.d. Do not heat, cut or weld tanks, drums or containers until the proper steps have been taken to insure that such procedures will not cause flammable or toxic vapors from substances inside. They can cause an explosion even though they have been "cleaned". For information, purchase "Recommended Safe Practices for the Preparation for Welding and Cutting of Containers and Piping That Have Held Hazardous Substances", AWS F4.1 from the American Welding Society (see address above).
- 6.e. Vent hollow castings or containers before heating, cutting or welding. They may explode.
- 6.f. Sparks and spatter are thrown from the welding arc. Wear oil free protective garments such as leather gloves, heavy shirt, cuffless trousers, high shoes and a cap over your hair. Wear ear plugs when welding out of position or in confined places. Always wear safety glasses with side shields when in a welding area.
- 6.g. Connect the work cable to the work as close to the welding area as practical. Work cables connected to the building framework or other locations away from the welding area increase the possibility of the welding current passing through lifting chains, crane cables or other alternate circuits. This can create fire hazards or overheat lifting chains or cables until they fail.
- 6.h. Also see item 1.c.
- 6.i. Read and follow NFPA 51B "Standard for Fire Prevention During Welding, Cutting and Other Hot Work", available from NFPA, 1 Batterymarch Park, PO box 9101, Quincy, MA 022690-9101.
- 6.j. Do not use a welding power source for pipe thawing.



## CYLINDER MAY EXPLODE IF DAMAGED.



- 7.a. Use only compressed gas cylinders containing the correct shielding gas for the process used and properly operating regulators designed for the gas and pressure used. All hoses, fittings, etc. should be suitable for the application and maintained in good condition.
- 7.b. Always keep cylinders in an upright position securely chained to an undercarriage or fixed support.
- 7.c. Cylinders should be located:
  - Away from areas where they may be struck or subjected to physical damage.
  - A safe distance from arc welding or cutting operations and any other source of heat, sparks, or flame.
- 7.d. Never allow the electrode, electrode holder or any other electrically "hot" parts to touch a cylinder.
- 7.e. Keep your head and face away from the cylinder valve outlet when opening the cylinder valve.
- 7.f. Valve protection caps should always be in place and hand tight except when the cylinder is in use or connected for use.
- 7.g. Read and follow the instructions on compressed gas cylinders, associated equipment, and CGA publication P-1, "Precautions for Safe Handling of Compressed Gases in Cylinders," available from the Compressed Gas Association, 14501 George Carter Way Chantilly, VA 20151.



## FOR ELECTRICALLY POWERED EQUIPMENT.



- 8.a. Turn off input power using the disconnect switch at the fuse box before working on the equipment.
- 8.b. Install equipment in accordance with the U.S. National Electrical Code, all local codes and the manufacturer's recommendations.
- 8.c. Ground the equipment in accordance with the U.S. National Electrical Code and the manufacturer's recommendations.

**Refer to**  
**<http://www.lincolnelectric.com/safety>**  
**for additional safety information.**

	Page
Definition of Welding Terms, Product Description .....	7
Recommended Processes, Equipment Limitations, Recommended Power Sources.....	7
<b>Installation .....</b>	<b>Section A</b>
Technical Specifications.....	A-1
Safety Precautions .....	A-2
Location.....	A-2
Weld Cable Sizes .....	A-2
Coaxial Weld Cable .....	A-3
Wire Drive Cable .....	A-4
Shielding Gas Connection.....	A-5
Procedure to Install Drive Rolls and Wire Guides.....	A-6
Pressure Arm Adjustment, Conduit Installation .....	A-7
System Set-Up.....	A-8
<b>Operation Section B</b>	
Safety Precautions .....	B-1
Graphic Symbols that appear on this Machine or in this Manual .....	B-1
Definition of Welding Terms .....	B-2
Product Description.....	B-2
Recommended Processes, Equipment Limitations, Recommended Power Sources .....	B-2
<b>Accessories .....</b>	<b>Section C</b>
Optimal Kits and Accessories .....	C-1
Drive Roll Kits used.....	C-1
Accessories Used .....	C-2, C-3
<b>Maintenance.....</b>	<b>Section D</b>
Safety Precautions .....	D-1
Routine Maintenance .....	D-1
<b>Troubleshooting.....</b>	<b>Section E</b>
How to Use Troubleshooting Guide .....	E-1
Troubleshooting Guide .....	E-2, E-3
<b>Wiring Diagram &amp; Dimension Prints .....</b>	<b>Section F</b>
<b>Parts List.....</b>	<b>parts.lincolnelectric.com</b>
Content/details may be changed or updated without notice. For most current Instruction Manuals, go to parts.lincolnelectric.com.	

## DEFINITION OF WELDING TERMS

### GMAW

- Gas Metal Arc welding

### FCAW

- Flux Core Arc Welding

### STT®

- Surface Tension Transfer

## PRODUCT DESCRIPTION

### General Physical Description

The AutoDrive® 4R220 wire feeders are powerful yet compact wire drives for robotic and hard automation applications.

The MAXTRAC 4 roll wire drive gives steady feeding of all wire sizes and types. The drive features split wire guides, tool-less drive roll changing, dual spring pressure arms and changeable gun bushings all mounted in a precision die cast aluminum frame. A right angle gear box efficiently transfers motor power for both high torque and high speed.

The AutoDrive® 4R220 features a powerful motor with an efficient two stage gearbox. This feeder is best for feeding larger diameter wires, pulling wire through long conduits, and in applications requiring extra ruggedness. A door covers the wire drive, protecting it from dust.

### General Functional Description

A high resolution tachometer precision for wire feeding forwards and in reverse.

For more information go to the following Web site:

<http://content.lincolnelectric.com/pdfs/products/literature/RoboticFeederSelectionChart.pdf>

## RECOMMENDED PROCESSES

- GMAW
- FCAW
- STT®

## PROCESS LIMITATIONS

K2685-3 AutoDrive® 4R220:

- Maximum wire size = 1/16 (1.6mm)

## EQUIPMENT LIMITATIONS

K2685-3 AutoDrive® 4R220

- Maximum GMAW gun length = 10' (3.1m)
- Maximum FCAW gun length = 15' (4.6m)
- Maximum wire drive control cable length = 100ft. (31m)
- Robot and power source software may need to be updated.
- Drive rolls are not included with the feeder.
- Mounts to FANUC ArcMate100iC arms.
- Mounts to FANUC ArcMate100iB arms.
- Maximum Conduit Length 50 Ft. (15m).

## RECOMMENDED POWER SOURCES

- Power Wave F355i
- Power Wave 455 (all models)
- Power Wave 455/STT M
- Power Wave 655/ R
- Power Wave 400i

**TECHNICAL SPECIFICATIONS – AutoDrive® 4R220 (K2685-3)****INPUT VOLTAGE, CURRENT**

INPUT VOLTAGE $\pm$ 10%	INPUT AMPERES
40 VDC	7A

**RATED OUTPUT @ 104°F (40°C)**

DUTY CYCLE	AMPERES	MOTOR POWER WATTS
100% rating	500	220

**GEARING - WIRE FEED SPEED RANGE-WIRE SIZE**

GEARING	GMAW		FCAW	
	WFS RANGE	WIRE SIZES	WFS RANGE	WIRE SIZES
K2685-3	50 – 1200 ipm (0.8 – 30.5m/min)	.023 – 1/16" (0.6 – 1.6mm)	50 – 1200 ipm (1.3 – 30.5m/min)	.035 - 5/64" (0.9 – 2.0mm)

**PHYSICAL DIMENSIONS**

HEIGHT	WIDTH	LENGTH	WEIGHT
10.43 Inches (265 mm)	10.07 Inches (256 mm)	9.92 Inches (252 mm)	20.9 lbs. (9.5 kg.)

**TEMPERATURE RANGE**

<b>OPERATION:</b>	-40°F to 104°F (-40°C to 40°C)
<b>STORAGE:</b>	-40°F to 185°F (-40°C to 85°C)



**SAFETY PRECAUTIONS**

**WARNING**



**ELECTRIC SHOCK CAN KILL.**

- Turn the input power OFF at the welding power source before installation or changing drive rolls and/or guides.
- Do not touch electrically live parts.
- When inching with the gun trigger, electrode and drive mechanism are "hot" to work and ground and could remain energized several seconds after the gun trigger is released.

- Welding power source must be connected to system ground per the National Electrical Code or any applicable local codes.
- Only qualified personnel should perform maintenance work.

**LOCATION**

Firmly secure the AutoDrive® 4R220 wire feeder to a robot arm or fixture.

See L15169 iB and L15169-1 iC Mechanical Installation Instructions which are supplied with this Instruction Manual in the literature package.

Mount only in a dry environment.

This equipment is for industrial use only and it is not intended for use in residential locations where the electrical power is provided by the public low-voltage supply system. There can be potential difficulties in residential locations due to conducted as well as radiated radio-frequency disturbances. The EMC or RF classification of this equipment is Class A.

**WELD CABLE SIZE**

Table A.1 located below are copper cable sizes recommended for different currents and duty cycles. Lengths stipulated are the distance from the welder to work and back to the welder again. Cable sizes are increased for greater lengths primarily for the purpose of minimizing cable drop.

**TABLE A.1**

RECOMMENDED CABLE SIZES (RUBBER COVERED COPPER - RATED 167°F or 75°C)**						
AMPERES	PERCENT DUTY CYCLE	CABLE SIZES FOR COMBINED LENGTHS OF ELECTRODE AND WORK CABLES				
		0 to 50Ft. (0 to15m)	50 to 100Ft. (15 to 30m)	100 to 150 Ft. (30 to 46m)	150 to 200 Ft. (46 to 61m)	200 to 250 Ft. (61 to 76m)
200	60	2	2	2	1	1/0
200	100	2	2	2	1	1/0
225	20	4 or 5	3	2	1	1/0
225	40 & 30	3	3	2	1	1/0
250	30	3	3	2	1	1/0
250	40	2	2	1	1	1/0
250	60	1	1	1	1	1/0
250	100	1	1	1	1	1/0
300	60	1	1	1	1/0	2/0
325	100	2/0	2/0	2/0	2/0	3/0
350	60	1/0	1/0	2/0	2/0	3/0
400	60	2/0	2/0	2/0	3/0	4/0
400	100	3/0	3/0	3/0	3/0	4/0
500	60	2/0	2/0	3/0	3/0	4/0

\*\* Tabled values are for operation at ambient temperatures of 104°F(40°C) and below. Applications above 104°F(40°C) may require cables larger than recommended, or cables rated higher than 167°F(75°C).

**COAXIAL WELD CABLE**

Coaxial welding cables are specially designed welding cables for STT® and pulse welding. Coaxial weld cables feature low inductance, allowing fast changes in the weld current. Regular cables have a higher inductance which may distort the STT® waveshape. Inductance becomes more severe as the weld cables become longer.

Coaxial weld cables are recommended for STT® welding, especially when the total weld cable length (electrode cable + work cable) exceeds 50 feet (7.6m). See Table A.2.

A coaxial weld cable is constructed with multiple small leads wrapped around one large lead. The large inner lead connects to the electrode stud on the power source and the electrode connection on the wire feeder. The small leads combine together to form the work lead, one end attached to the power source and the other end to the work piece.

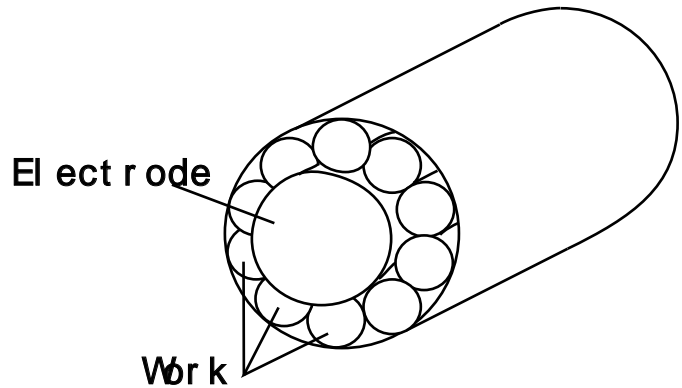

To install:

1. Turn the input power off at the welding power source.
2. Connect one end of the center lead to the power source electrode connection, and the other end to the wire feeder electrode connection.
3. Connect the outer lead bundle to the power source work connection, and the other end to the work piece. Minimize the length of any work lead extension for best results.
4. Insulate all connections.

**TABLE A.2**

RECOMMENDED CABLE SIZES (RUBBER COVERED COPPER - RATED 75°C)**					
Amperes	Duty Cycle	COAXIAL CABLE LENGTH			
		0 to 25 Ft.	25 to 50 Ft.	50 to 75 Ft.	75 to 100 Ft.
250	100%	1	1	1	1
300	60%	1	1	1	1/0
350	60%	1/0	1/0	--	--

\*\* Tabled values are for operation at ambient temperatures of 104°F(40°C) and below. Applications above 104°F(40°C) may require cables larger than recommended, or cables rated higher than 167°F(75°C).

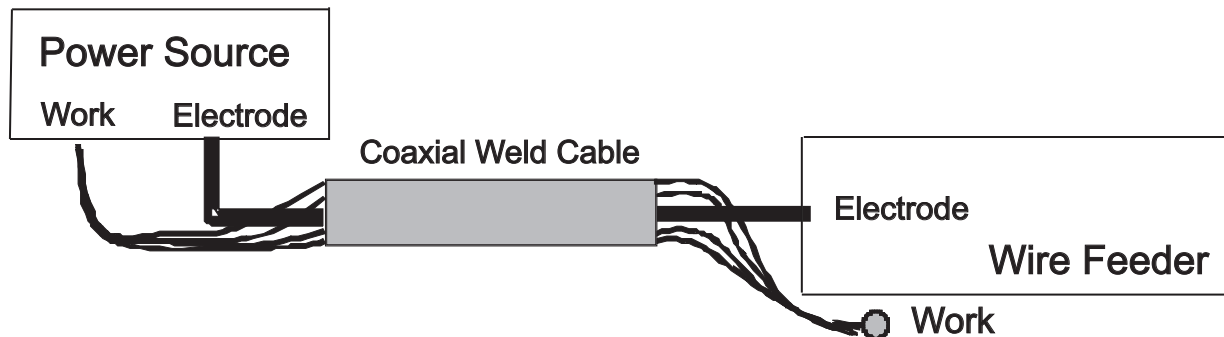

**WIRE DRIVE CABLE, K1785-XX**

Wire drive cables are used to connect power sources and control boxes to remote wire drives.

The cables have a 14 pin connector at each end. **Both ends of the cable have a collar and the cables cannot be “daisy chained” to make a longer cable.**

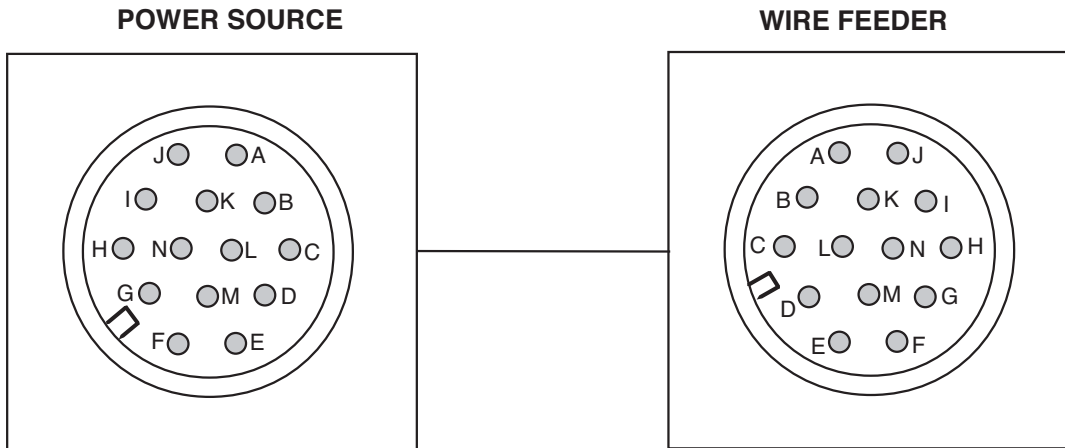

POWER SOURCE	
Pin	Function
A	Motor Power
B	Motor Power
C	Gas Solenoid
D	Gas Solenoid
E	Reserved
F	Reserved
G	“2A” Differential Tachometer
H	“2B” Differential Tachometer
I	Reserved
J	Reserved
K	“1A” Differential Tachometer
L	“1B” Differential Tachometer
M	Reserved
N	“67” Electrode Sense Lead

WIRE FEEDER	
Pin	Function
A	Motor Power
B	Motor Power
C	Gas Solenoid
D	Gas Solenoid
E	“2A” Differential Tachometer
F	Reserved
G	+15VDC Tech Supply
H	Tachometer Common
I	Reserved
J	Reserved
K	“1A” Differential Tachometer
L	“1B” Differential Tachometer
M	“2B” Differential Tachometer
N	“67” Electrode Sense Lead

## SHIELDING GAS CONNECTION

**WARNING**

**CYLINDER may explode if damaged.**

• **Keep cylinder upright and chained to support.**

- **Keep cylinder away from areas where it may be damaged.**
- **Never lift welder with cylinder attached.**
- **Never allow welding electrode to touch cylinder.**
- **Keep cylinder away from welding or other live electrical circuits.**
- **BUILD UP OF SHIELDING GAS MAY HARM HEALTH OR KILL.**

- **Shut off shielding gas supply when not in use.**

- **See American National Standard Z-49.1, "Safety in Welding and Cutting" Published by the American Welding Society.**



Maximum inlet pressure is 100 psi. (6.9 bar.)

Install the shielding gas supply as follows:

1. Secure the cylinder to prevent it from falling.
2. Remove the cylinder cap. Inspect the cylinder valves and regulator for damaged threads, dirt, dust, oil or grease. Remove dust and dirt with a clean cloth. **DO NOT ATTACH THE REGULATOR IF OIL, GREASE OR DAMAGE IS PRESENT!** Inform your gas supplier of this condition. Oil or grease in the presence of high pressure oxygen is explosive.
3. Stand to one side away from the outlet and open the cylinder valve for an instant. This blows away any dust or dirt which may have accumulated in the valve outlet.
4. Attach the flow regulator to the cylinder valve and tighten the union nut(s) securely with a wrench. Note: if connecting to 100% CO<sub>2</sub> cylinder, insert regulator adapter between regulator and cylinder valve. If adapter is equipped with a plastic washer, be sure it is seated for connection to the CO<sub>2</sub> cylinder.

5. Attach one end of the inlet hose to the outlet fitting of the flow regulator. Attach the other end to the welding system shielding gas inlet. Tighten the union nuts with a wrench.
6. Before opening the cylinder valve, turn the regulator adjusting knob counterclockwise until the adjusting spring pressure is released.
7. Standing to one side, open the cylinder valve slowly a fraction of a turn. When the cylinder pressure gage stops moving, open the valve fully.
8. The flow regulator is adjustable. Adjust it to the flow rate recommended for the procedure and process being used before making a weld.

## PROCEDURE TO INSTALL DRIVE ROLLS AND WIRE GUIDES



### WARNING

**ELECTRIC SHOCK can kill.**



- Turn the input power OFF at the welding power source before installation or changing drive rolls and/or guides.
- Do not touch electrically live parts.
- When inching with the gun trigger, electrode and drive mechanism are "hot" to work and ground and could remain energized several seconds after the gun trigger is released.
- Do not operate with covers, panels or guards removed or open.
- Only qualified personnel should perform maintenance work.

### To remove drive rolls and wire guides:

1. Turn power off at the welding power source.
2. Remove the outer wire guide.

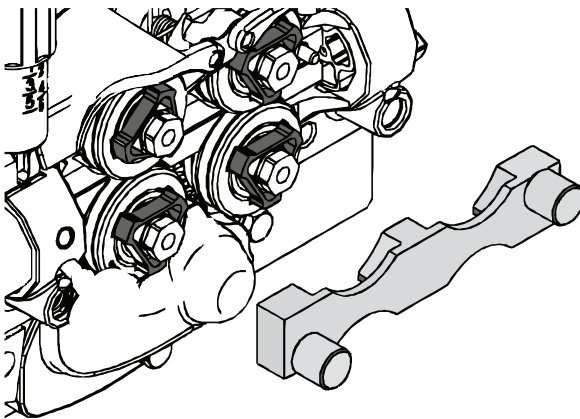

3. Rotate all of the triangular rings to the unlocked position.

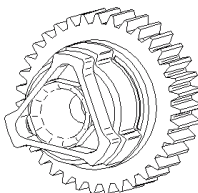

UNLOCKED  
POSITION

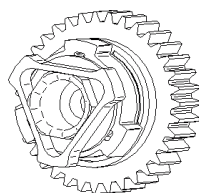

LOCKED  
POSITION

4. Open the idle arms.
5. Remove the drive rolls and inner wire guide.

### To install drive rolls and wire guides:

1. Turn off power at the welding power source.
2. Open the idle arms.
3. Assemble the inner wire guide.

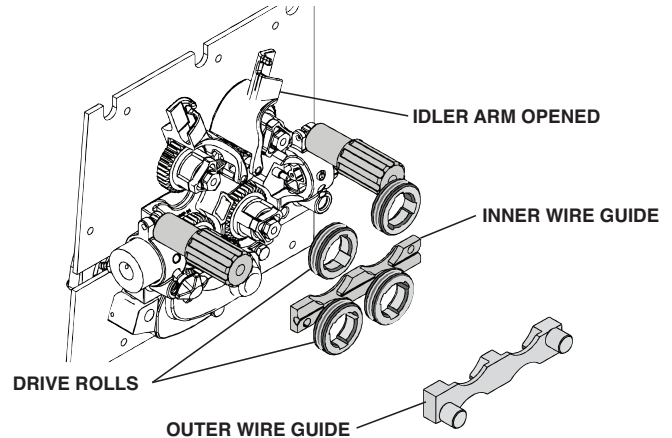

4. Slide the drive rolls onto the drive hubs.
5. Close the idle arms.
6. Rotate all of the triangular rings to the locked position.
7. Assemble the outer wire guide.
8. Adjust the pressure arms to the recommended setting.

**PRESSURE ARM ADJUSTMENT**

**WARNING**

**ELECTRIC SHOCK can kill.**



- Turn the input power OFF at the welding power source before installation or changing drive rolls and/or guides.
- Do not touch electrically live parts.
- When inching with the gun trigger, electrode and drive mechanism are "hot" to work and ground and could remain energized several seconds after the gun trigger is released.
- Do not operate with covers, panels or guards removed or open.
- Only qualified personnel should perform maintenance work.

The pressure arm controls the amount of force the drive rolls exert on the wire. Proper adjustment of the pressure arm gives the best welding performance.

Set the pressure arm as follows:  
(See Figure A.3)

Aluminum wires	between 1 and 3
Cored wires	between 3 and 4
Steel, Stainless wires	between 4 and 6

**FIGURE A.3**

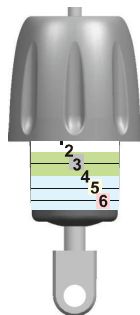

**CONDUIT INSTALLATION**

The K1546-xx series of conduits are compatible with K515-xx, K565-xx, Wire Wizard and Electron Beam Technologies conduits.

**To install conduit to the wire drive:**

1. Slide the conduit bushing into the feed plate and secure with the set screw.
2. Slide the conduit into the bushing and lock in place with the thumb screw.

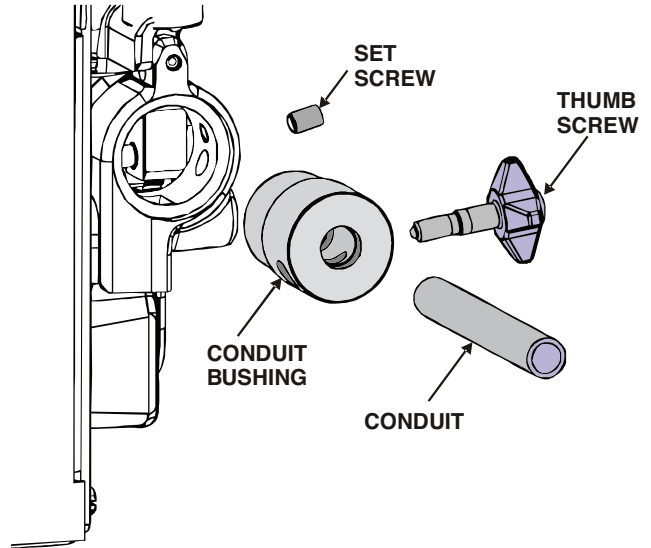

**LOADING WIRE**

**WARNING**



- Keep hands, hair, clothing and tools away from rotating equipment.
- Do not wear gloves when threading wire or changing wire spool.
- Only qualified personnel should install, use or service this equipment.

SYSTEM SET-UP

# SYSTEM SET-UP (SINGLE ARM)

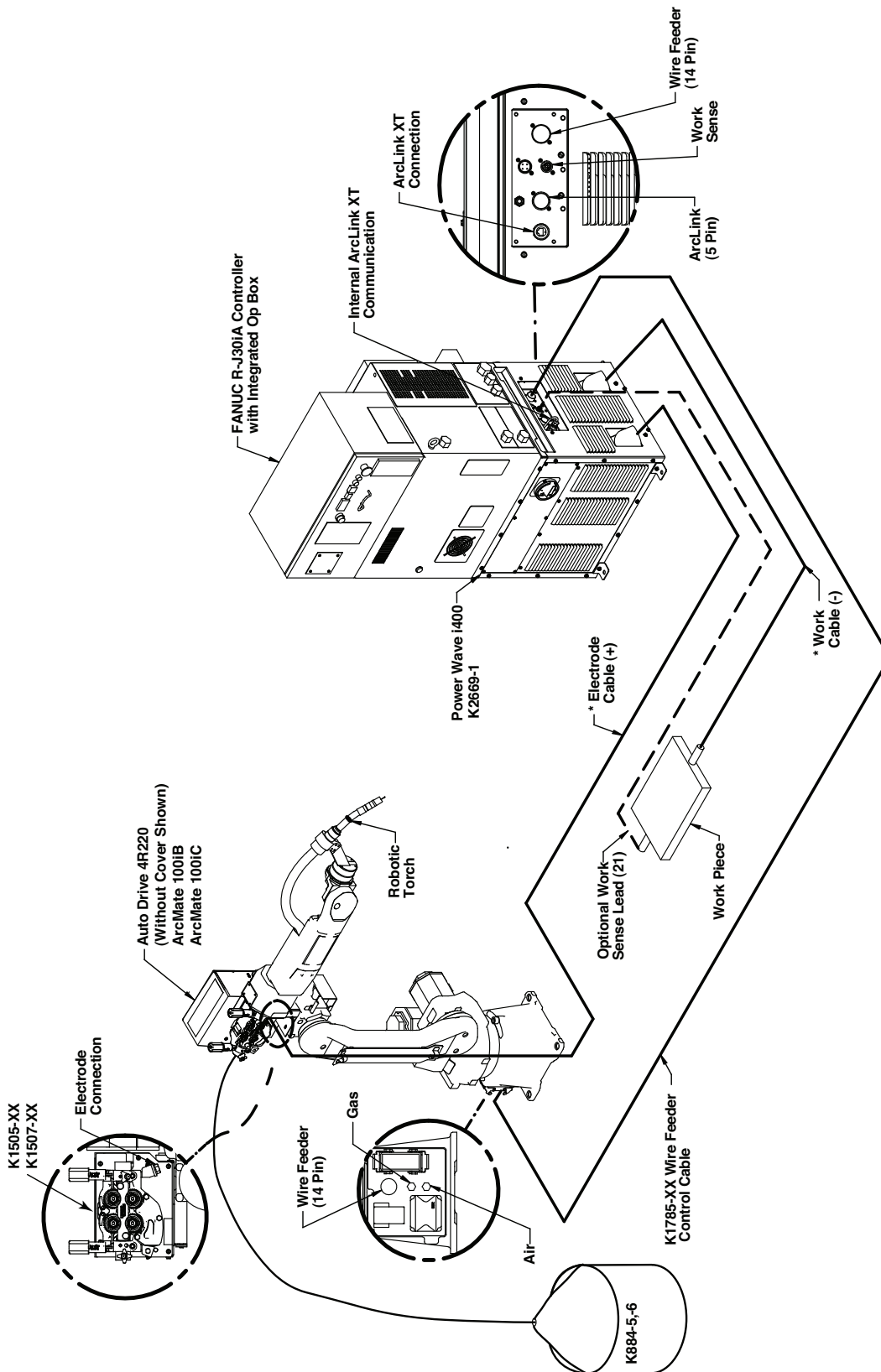

\* Refer to "Output Cable Guidelines" for recommended cable size

**SAFETY PRECAUTIONS**

READ AND UNDERSTAND ENTIRE SECTION BEFORE OPERATING MACHINE.

**WARNING**



• **ELECTRIC SHOCK CAN KILL.** Unless using COLD FEED feature, when feeding with gun trigger, the electrode and drive mechanism are always electrically energized and could remain energized several seconds after the welding ceases..

- Do not touch electrically live part or electrode with skin or wet clothing.
- Insulate yourself from work and ground.
- Always wear dry insulating gloves.
- Do not operate with covers, panels or guards removed or open.



• **FUMES AND GASSES** can be dangerous.

- Keep your head out of fumes.
- Use ventilation or exhaust to remove fumes from breathing zone.



• **WELDING SPARKS** can cause fire or explosion.

- Keep flammable material away.



**ARC RAYS** can burn.

- Wear eye, ear and body protection.

SEE ADDITIONAL WARNING INFORMATION UNDER ARC WELDING SAFETY PRECAUTIONS AND IN THE FRONT OF THIS OPERATING MANUAL.

**GRAPHIC SYMBOLS THAT APPEAR ON THIS MACHINE OR IN THIS MANUAL**



WIRE FEEDER



POSITIVE OUTPUT



NEGATIVE OUTPUT



INPUT POWER



DIRECT CURRENT

$U_0$

OPEN CIRCUIT VOLTAGE

$U_1$

INPUT VOLTAGE

$U_2$

OUTPUT VOLTAGE

$I_1$

INPUT CURRENT

$I_2$

OUTPUT CURRENT



PROTECTIVE GROUND











WARNING OR CAUTION



## OPTIONAL KITS AND ACCESSORIES

## DRIVE ROLL KITS 4 ROLL DRIVE

WIRE TYPE	KITS	ELECTRODE SIZE		
Steel Wires:	KP1505-030S KP1505-035S KP1505-040S KP1505-045S	.023-.030 (0.6-0.8mm) .035 (0.9mm) .040 (1.0mm) .045 (1.2mm)	Includes: 4 V groove drive rolls and inner wire guide.	
Cored Wires:	KP1505-035C KP1505-045C	.030-.035" (0.8-0.9mm) .040-.045" (1.0-1.2mm)	Includes: 4 Knurled drive rolls and inner wire guide.	
Aluminum Wires:	KP1507-3/64A	3/64" (1.2mm)	Includes: 4 polished U groove drive rolls, outer wire guide and inner wire guide.	

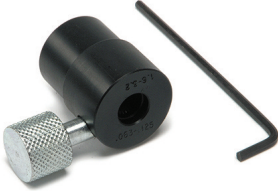
<p>K1500-1</p>	<p>Gun Receiver Bushing (for guns with K466-1 Lincoln gun connectors; Innershield and Subarc guns)</p>	<p>Includes: Gun receiver bushing, set screw and hex key wrench.</p>	
<p>K1500-2</p>	<p>Gun Receiver Bushing (for guns with K466-2, K466-10 Lincoln gun connectors; Magnum 200/300/400 guns and compatible with Tweco® #2-#4)</p>	<p>Includes: Gun receiver bushing with hose nipple, set screw and hex key wrench.</p>	
<p>K1500-3</p>	<p>Gun Receiver Bushing (for guns with K613-7 Lincoln gun connectors; Magnum 550 guns and compatible with Tweco® #5)</p>	<p>Includes: Gun receiver bushing with hose nipple, set screw and hex key wrench.</p>	
<p>K1500-4</p>	<p>Gun Receiver Bushing (for gun with K466-3 Lincoln gun connectors; compatible with Miller® guns.)</p>	<p>Includes: Gun receiver bushing with hose nipple, set screw and hex key wrench.</p>	
<p>K1500-5</p>	<p>Gun Receiver Bushing (compatible with Oxo® guns.)</p>	<p>Includes: Gun receiver bushing with hose nipple, 4 guide tubes, set screw and hex key wrench.</p>	
<p>K489-7</p>	<p>Gun Receiver Bushing (for Lincoln Fast-Mate guns.)</p>	<p>Includes: Gun receiver bushing with trigger connector.</p>	
<p>K515-xx</p>	<p>Wire Conduit</p>	<p>Requires K1546-1</p>	
<p>K565-xx</p>	<p>Wire Conduit</p>	<p>Requires K1546-1</p>	
<p>K1546-1</p>	<p>Incoming Bushing, for Lincoln Conduit .025- 1/16" (0.6 - 1.6mm) wire. Compatible with Electron Beam Conduit.</p>	<p>Includes: Incoming bushing and hex key wrench.</p>	

K2175-1	500 lb Accu-Pak Box Payoff Kit	
K2175-2	1000 lb Accu-Pak Box Payoff Kit	
K895-2	Rotary Wire Dispenser	
K836-1	Dereeler Adapter	
K884-5	Accu-Trak Drum Payoff Kit – 20 inch diameter	
K884-6	Accu-Trak Drum Payoff Kit – 23 inch diameter	
K1796-xx	Coaxial Cables	Includes: 1 cable of length “xx” feet. 14 pin connectors on both ends. Cable length cannot be extended by connecting K1785 cables together.
K2593-xx	Coaxial Cables	
K1785-xx	Wire Drive Cables	Includes: 1 cable of length “xx” feet. 14 pin connectors on both ends. Has collars at both ends. Used with FANUC arms that have an integrated cable.
K2709-xx	Wire Drive Cables	Includes: 1 cable of length “xx” feet. 14 pins connectors on both ends. May be daisy chained to make a longer cable. Used with FANUC arms that do not have an integrated cable.
K1733-1	Wire Straightener	Includes: 1 wire straightener

## SAFETY PRECAUTIONS



### WARNING



**ELECTRIC SHOCK can kill.**

- Turn the input power OFF at the welding power source before installation or changing drive rolls and/or guides.
  - Do not touch electrically live parts.
  - When inching with the gun trigger, electrode and drive mechanism are "hot" to work and ground and could remain energized several seconds after the gun trigger is released.
- Do not operate with covers, panels or guards removed or open.
  - Only qualified personnel should perform maintenance work.
- 

## ROUTINE MAINTENANCE

To Install or remove the AutoDrive® 4R220 for servicing:

Every 6 months or every 2.5 million arc starts (whichever comes first), inspect the motor brushes. Replace if shorter than 0.5" (12.7mm).

See **Installation Section** of this Instruction Manual.

## HOW TO USE TROUBLESHOOTING GUIDE

### WARNING

Service and Repair should only be performed by Lincoln Electric Factory Trained Personnel. Unauthorized repairs performed on this equipment may result in danger to the technician and machine operator and will invalidate your factory warranty. For your safety and to avoid Electrical Shock, please observe all safety notes and precautions detailed throughout this manual.

This Troubleshooting Guide is provided to help you locate and repair possible machine malfunctions. Simply follow the three-step procedure listed below.

#### **Step 1. LOCATE PROBLEM (SYMPTOM).**

Look under the column labeled "PROBLEM (SYMPTOMS)". This column describes possible symptoms that the machine may exhibit. Find the listing that best describes the symptom that the machine is exhibiting.

#### **Step 2. POSSIBLE CAUSE.**

The second column labeled "POSSIBLE CAUSE" lists the obvious external possibilities that may contribute to the machine symptom.

#### **Step 3. RECOMMENDED COURSE OF ACTION**

This column provides a course of action for the Possible Cause, generally it states to contact your local Lincoln Authorized Field Service Facility.

If you do not understand or are unable to perform the Recommended Course of Action safely, contact your local Lincoln Authorized Field Service Facility.

### WARNING



#### **ELECTRIC SHOCK can kill.**

- Turn the input power OFF at the welding power source before installation or changing drive rolls and/or guides.
- Do not touch electrically live parts.
- When inching with the gun trigger, electrode and drive mechanism are "hot" to work and ground and could remain energized several seconds after the gun trigger is released.
- Welding power source must be connected to system ground per the National Electrical Code or any applicable local codes.
- Only qualified personnel should perform maintenance work.

### CAUTION

If for any reason you do not understand the test procedures or are unable to perform the tests/repairs safely, contact your **Local Lincoln Authorized Field Service Facility** for technical troubleshooting assistance before you proceed.

Observe all Safety Guidelines detailed throughout this manual

PROBLEMS (SYMPTOMS)	POSSIBLE CAUSE	RECOMMENDED COURSE OF ACTION
The wire feeder does not feed wire and the drive rolls do not spin.	<ol style="list-style-type: none"> <li>1. Verify the power source is turned on.</li> <li>2. Verify the circuit breaker for the wire feeder on the power source has not tripped.</li> <li>3. Verify power is being supplied to the wire feeder.</li> </ol>	
The wire feeds erratically.	<ol style="list-style-type: none"> <li>1. Verify the correct drive rolls and inner wire guide are installed in the wire drive.</li> <li>2. Check for sharp bends in the gun liner or conduit.</li> <li>3. Examine the contact tip for wear and proper size. Replace as necessary.</li> <li>4. Check the gun liner and conduit. The welding electrode should slide easily through both.</li> <li>5. Verify the proper gun liner is installed.</li> <li>6. Verify the pressure arms are set properly. Too much pressure may crush the wire.</li> <li>7. Inspect the motor for worn brushes.</li> </ol>	
No shielding gas Variable or "hunting" arc.	<ol style="list-style-type: none"> <li>1. Verify the gas supply is turned on and not empty.</li> <li>2. Check the gas hose for cuts. Make sure it is not crushed.</li> <li>3. Verify the shielding gas hose is connected to the gun bushing or welding gun.</li> </ol>	

 **CAUTION**

If for any reason you do not understand the test procedures or are unable to perform the tests/repairs safely, contact your **Local Lincoln Authorized Field Service Facility** for technical troubleshooting assistance before you proceed.

Observe all Safety Guidelines detailed throughout this manual

PROBLEMS (SYMPTOMS)	POSSIBLE CAUSE	RECOMMENDED COURSE OF ACTION
<b>Output Problems</b>		
Variable or "hunting" arc.	<ol style="list-style-type: none"> <li>1. Check for proper size contact. Make sure the contact tip is not worn, free of spatter and not melted.</li> <li>2. Clean and tighten all electrode and work connections.</li> <li>3. Verify the proper polarity is being used for the weld procedure.</li> <li>4. Make sure the proper electrode stick-out is being maintained.</li> <li>5. Check the gas flow rate and mixture.</li> <li>6. Verify the gun bushing is tightly mounted to the wire drive.</li> <li>7. Verify the gun is tightly mounted to the gun bushing.</li> <li>8. Verify the electrode lead is connected to the proper connection block on the feed head.</li> <li>9. Inspect the motor for worn brushes.</li> </ol>	
The motor overload errors occur.	<ol style="list-style-type: none"> <li>1. Check for sharp bends in the gun liner and conduit.</li> <li>2. Examine the contact tip for wear and proper size. Replace as necessary.</li> <li>3. Check the gun liner and conduit. The welding electrode should slide easily through both.</li> <li>4. Verify the proper gun liner is installed.</li> <li>5. Reduce the pressure arm setting.</li> </ol>	

 **CAUTION**

If for any reason you do not understand the test procedures or are unable to perform the tests/repairs safely, contact your **Local Lincoln Authorized Field Service Facility** for technical troubleshooting assistance before you proceed.

# WIRING DIAGRAM AUTODRIVE FEEDER FOR CODE 12417

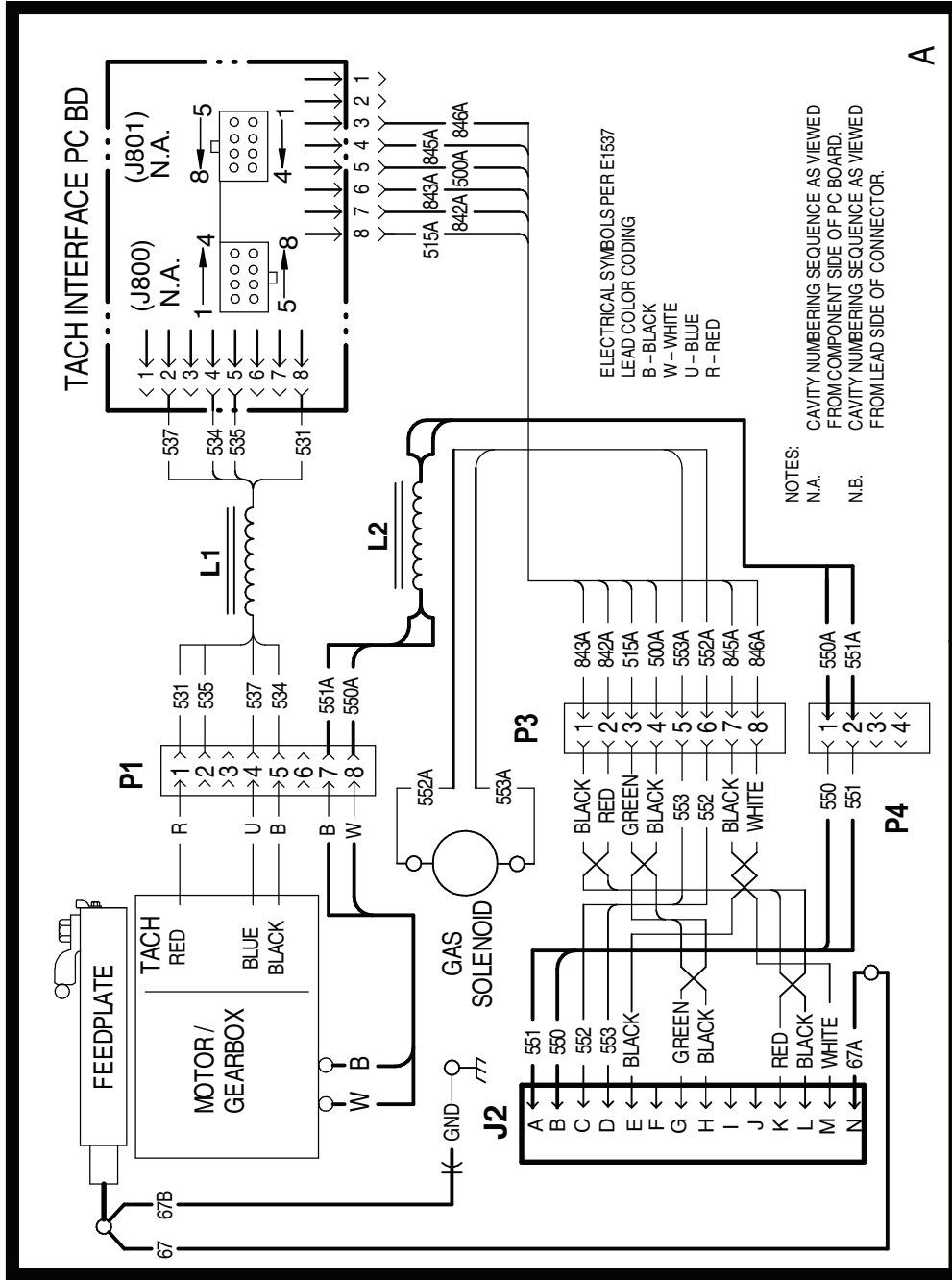

M 21562-1

NOTE: This diagram is for reference only. It may not be accurate for all machines covered by this manual. The specific diagram for a particular code is pasted inside the machine on one of the enclosure panels. If the diagram is illegible, write to the Service Department for a replacement. Give the equipment code number.



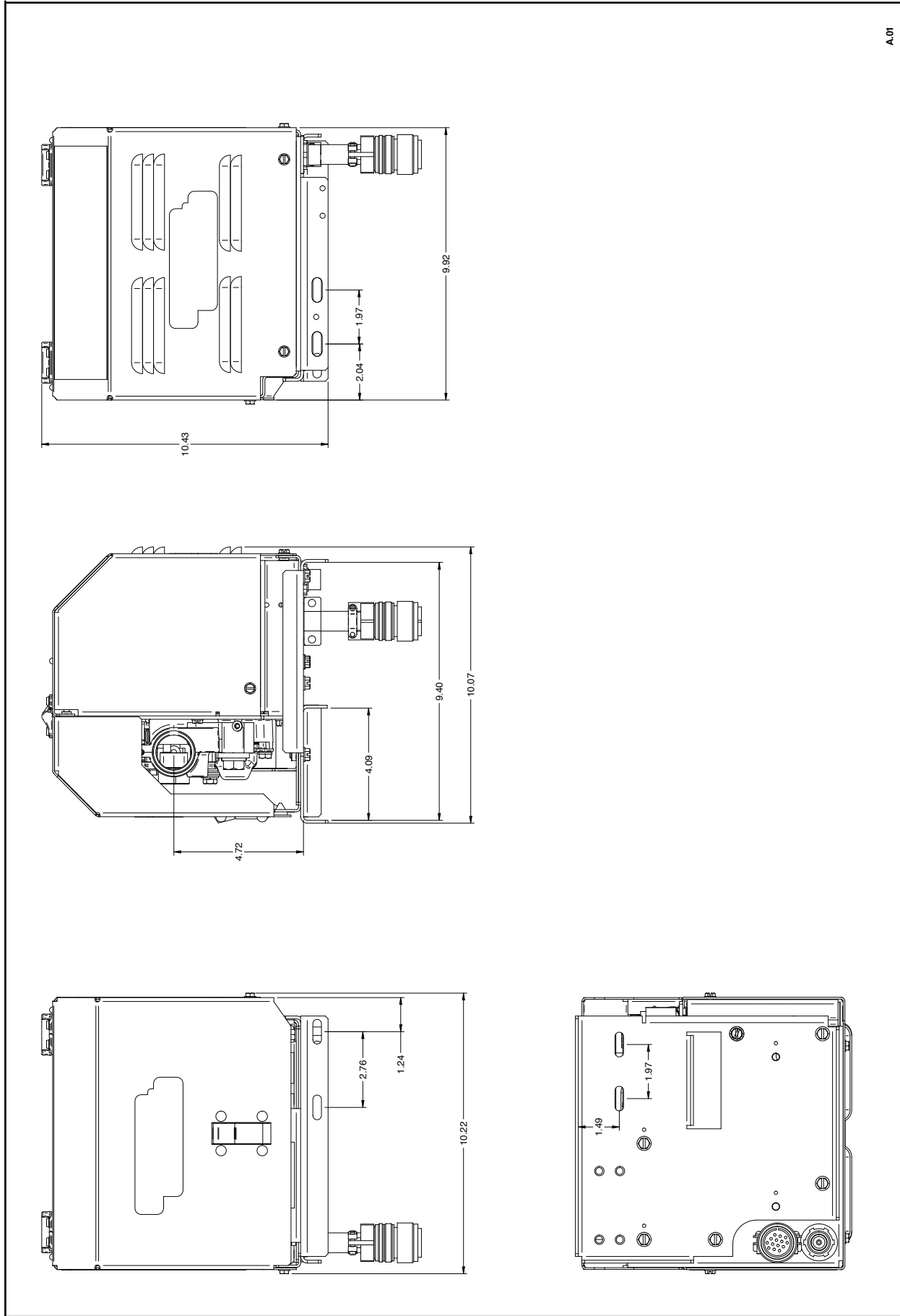

A.01

L15157

<b>WARNING</b>	<ul style="list-style-type: none"> <li>Do not touch electrically live parts or electrode with skin or wet clothing.</li> <li>Insulate yourself from work and ground.</li> </ul>	<ul style="list-style-type: none"> <li>Keep flammable materials away.</li> </ul>	<ul style="list-style-type: none"> <li>Wear eye, ear and body protection.</li> </ul>
Spanish <b>AVISO DE PRECAUCION</b>	<ul style="list-style-type: none"> <li>No toque las partes o los electrodos bajo carga con la piel o ropa mojada.</li> <li>Aislese del trabajo y de la tierra.</li> </ul>	<ul style="list-style-type: none"> <li>Mantenga el material combustible fuera del área de trabajo.</li> </ul>	<ul style="list-style-type: none"> <li>Protéjase los ojos, los oídos y el cuerpo.</li> </ul>
French <b>ATTENTION</b>	<ul style="list-style-type: none"> <li>Ne laissez ni la peau ni des vêtements mouillés entrer en contact avec des pièces sous tension.</li> <li>Isolez-vous du travail et de la terre.</li> </ul>	<ul style="list-style-type: none"> <li>Gardez à l'écart de tout matériel inflammable.</li> </ul>	<ul style="list-style-type: none"> <li>Protégez vos yeux, vos oreilles et votre corps.</li> </ul>
German <b>WARNUNG</b>	<ul style="list-style-type: none"> <li>Berühren Sie keine stromführenden Teile oder Elektroden mit Ihrem Körper oder feuchter Kleidung!</li> <li>Isolieren Sie sich von den Elektroden und dem Erdboden!</li> </ul>	<ul style="list-style-type: none"> <li>Entfernen Sie brennbares Material!</li> </ul>	<ul style="list-style-type: none"> <li>Tragen Sie Augen-, Ohren- und Körperschutz!</li> </ul>
Portuguese <b>ATENÇÃO</b>	<ul style="list-style-type: none"> <li>Não toque partes elétricas e electrodos com a pele ou roupa molhada.</li> <li>Isole-se da peça e terra.</li> </ul>	<ul style="list-style-type: none"> <li>Mantenha inflamáveis bem guardados.</li> </ul>	<ul style="list-style-type: none"> <li>Use proteção para a vista, ouvido e corpo.</li> </ul>
Japanese <b>注意事項</b>	<ul style="list-style-type: none"> <li>通電中の電気部品、又は溶材にヒフやぬれた布で触れないこと。</li> <li>施工物やアースから身体が絶縁されている様にして下さい。</li> </ul>	<ul style="list-style-type: none"> <li>燃えやすいものの側での溶接作業は絶対にしてはなりません。</li> </ul>	<ul style="list-style-type: none"> <li>目、耳及び身体に保護具をして下さい。</li> </ul>
Chinese <b>警告</b>	<ul style="list-style-type: none"> <li>皮肤或湿衣物切勿接触带电部件及焊条。</li> <li>使你自已与地面和工作件绝缘。</li> </ul>	<ul style="list-style-type: none"> <li>把一切易燃物品移离工作场所。</li> </ul>	<ul style="list-style-type: none"> <li>佩戴眼、耳及身体劳动保护用具。</li> </ul>
Korean <b>위험</b>	<ul style="list-style-type: none"> <li>전도체나 용접봉을 젖은 헝겍 또는 피부로 절대 접촉치 마십시오.</li> <li>모재와 접지를 접촉치 마십시오.</li> </ul>	<ul style="list-style-type: none"> <li>인화성 물질을 접근시키지 마십시오.</li> </ul>	<ul style="list-style-type: none"> <li>눈, 귀와 몸에 보호장구를 착용하십시오.</li> </ul>
Arabic <b>تحذير</b>	<ul style="list-style-type: none"> <li>لا تلمس الاجزاء التي يسري فيها التيار الكهربائي أو الألكترود بجسد الجسم أو بالملابس المبللة بالماء.</li> <li>ضع عازلا على جسمك خلال العمل.</li> </ul>	<ul style="list-style-type: none"> <li>ضع المواد القابلة للاشتعال في مكان بعيد.</li> </ul>	<ul style="list-style-type: none"> <li>ضع أدوات وملابس واقية على عينيك وأذنيك وجسمك.</li> </ul>

READ AND UNDERSTAND THE MANUFACTURER'S INSTRUCTION FOR THIS EQUIPMENT AND THE CONSUMABLES TO BE USED AND FOLLOW YOUR EMPLOYER'S SAFETY PRACTICES.

SE RECOMIENDA LEER Y ENTENDER LAS INSTRUCCIONES DEL FABRICANTE PARA EL USO DE ESTE EQUIPO Y LOS CONSUMIBLES QUE VA A UTILIZAR, SIGA LAS MEDIDAS DE SEGURIDAD DE SU SUPERVISOR.

LISEZ ET COMPRENEZ LES INSTRUCTIONS DU FABRICANT EN CE QUI REGARDE CET EQUIPMENT ET LES PRODUITS A ETRE EMPLOYES ET SUIVEZ LES PROCEDURES DE SECURITE DE VOTRE EMPLOYEUR.

LESEN SIE UND BEFOLGEN SIE DIE BETRIEBSANLEITUNG DER ANLAGE UND DEN ELEKTRODENEINSATZ DES HERSTELLERS. DIE UNFALLVERHÜTUNGSVORSCHRIFTEN DES ARBEITGEBERS SIND EBENFALLS ZU BEACHTEN.

			
<ul style="list-style-type: none"> <li>● Keep your head out of fumes.</li> <li>● Use ventilation or exhaust to remove fumes from breathing zone.</li> </ul>	<ul style="list-style-type: none"> <li>● Turn power off before servicing.</li> </ul>	<ul style="list-style-type: none"> <li>● Do not operate with panel open or guards off.</li> </ul>	<b>WARNING</b>
<ul style="list-style-type: none"> <li>● Los humos fuera de la zona de respiración.</li> <li>● Mantenga la cabeza fuera de los humos. Utilice ventilación o aspiración para gases.</li> </ul>	<ul style="list-style-type: none"> <li>● Desconectar el cable de alimentación de poder de la máquina antes de iniciar cualquier servicio.</li> </ul>	<ul style="list-style-type: none"> <li>● No operar con panel abierto o guardas quitadas.</li> </ul>	Spanish <b>AVISO DE PRECAUCION</b>
<ul style="list-style-type: none"> <li>● Gardez la tête à l'écart des fumées.</li> <li>● Utilisez un ventilateur ou un aspirateur pour ôter les fumées des zones de travail.</li> </ul>	<ul style="list-style-type: none"> <li>● Débranchez le courant avant l'entretien.</li> </ul>	<ul style="list-style-type: none"> <li>● N'opérez pas avec les panneaux ouverts ou avec les dispositifs de protection enlevés.</li> </ul>	French <b>ATTENTION</b>
<ul style="list-style-type: none"> <li>● Vermeiden Sie das Einatmen von Schweißrauch!</li> <li>● Sorgen Sie für gute Be- und Entlüftung des Arbeitsplatzes!</li> </ul>	<ul style="list-style-type: none"> <li>● Strom vor Wartungsarbeiten abschalten! (Netzstrom völlig öffnen; Maschine anhalten!)</li> </ul>	<ul style="list-style-type: none"> <li>● Anlage nie ohne Schutzgehäuse oder Innenschutzverkleidung in Betrieb setzen!</li> </ul>	German <b>WARNUNG</b>
<ul style="list-style-type: none"> <li>● Mantenha seu rosto da fumaça.</li> <li>● Use ventilação e exaustão para remover fumo da zona respiratória.</li> </ul>	<ul style="list-style-type: none"> <li>● Não opere com as tampas removidas.</li> <li>● Desligue a corrente antes de fazer serviço.</li> <li>● Não toque as partes elétricas nuas.</li> </ul>	<ul style="list-style-type: none"> <li>● Mantenha-se afastado das partes moventes.</li> <li>● Não opere com os painéis abertos ou guardas removidas.</li> </ul>	Portuguese <b>ATENÇÃO</b>
<ul style="list-style-type: none"> <li>● ヒュームから頭を離すようにして下さい。</li> <li>● 換気や排煙に十分留意して下さい。</li> </ul>	<ul style="list-style-type: none"> <li>● メンテナンス・サービスに取りかかる際には、まず電源スイッチを必ず切して下さい。</li> </ul>	<ul style="list-style-type: none"> <li>● パネルやカバーを取り外したままで機械操作をしないで下さい。</li> </ul>	Japanese <b>注意事項</b>
<ul style="list-style-type: none"> <li>● 頭部遠離煙霧。</li> <li>● 在呼吸區使用通風或排風器除煙。</li> </ul>	<ul style="list-style-type: none"> <li>● 維修前切斷電源。</li> </ul>	<ul style="list-style-type: none"> <li>● 儀表面板打開或沒有安全罩時不準作業。</li> </ul>	Chinese <b>警告</b>
<ul style="list-style-type: none"> <li>● 얼굴로부터 용접가스를 멀리하십시오.</li> <li>● 호흡지역으로부터 용접가스를 제거하기 위해 가스제거기나 통풍기를 사용하십시오.</li> </ul>	<ul style="list-style-type: none"> <li>● 보수전에 전원을 차단하십시오.</li> </ul>	<ul style="list-style-type: none"> <li>● 판넬이 열린 상태로 작동치 마십시오.</li> </ul>	Korean <b>위험</b>
<ul style="list-style-type: none"> <li>● ابعد رأسك بعيداً عن الدخان.</li> <li>● استعمل التهوية أو جهاز ضغط الدخان للخارج لكي تبعد الدخان عن المنطقة التي تتنفس فيها.</li> </ul>	<ul style="list-style-type: none"> <li>● اقطع التيار الكهربائي قبل القيام بأية صيانة.</li> </ul>	<ul style="list-style-type: none"> <li>● لا تشغيل هذا الجهاز اذا كانت الاغطية الحديدية الواقية ليست عليه.</li> </ul>	Arabic <b>تحذير</b>

LEIA E COMPREENDA AS INSTRUÇÕES DO FABRICANTE PARA ESTE EQUIPAMENTO E AS PARTES DE USO, E SIGA AS PRÁTICAS DE SEGURANÇA DO EMPREGADOR.

使う機械や溶材のメーカーの指示書をよく読み、まず理解して下さい。そして貴社の安全規定に従って下さい。

請詳細閱讀並理解製造廠提供的說明以及應該使用的銀焊材料，並請遵守貴方的有關勞動保護規定。

이 제품에 동봉된 작업지침서를 숙지하시고 귀사의 작업자 안전수칙을 준수하시기 바랍니다.

اقرأ بتمعن وافهم تعليمات المصنع المنتج لهذه المعدات والمواد قبل استعمالها واتبع تعليمات الوقاية لصاحب العمل.

## **CUSTOMER ASSISTANCE POLICY**

The business of The Lincoln Electric Company is manufacturing and selling high quality welding equipment, consumables, and cutting equipment. Our challenge is to meet the needs of our customers and to exceed their expectations. On occasion, purchasers may ask Lincoln Electric for advice or information about their use of our products. We respond to our customers based on the best information in our possession at that time. Lincoln Electric is not in a position to warrant or guarantee such advice, and assumes no liability, with respect to such information or advice. We expressly disclaim any warranty of any kind, including any warranty of fitness for any customer's particular purpose, with respect to such information or advice. As a matter of practical consideration, we also cannot assume any responsibility for updating or correcting any such information or advice once it has been given, nor does the provision of information or advice create, expand or alter any warranty with respect to the sale of our products.

Lincoln Electric is a responsive manufacturer, but the selection and use of specific products sold by Lincoln Electric is solely within the control of, and remains the sole responsibility of the customer. Many variables beyond the control of Lincoln Electric affect the results obtained in applying these types of fabrication methods and service requirements.

Subject to Change – This information is accurate to the best of our knowledge at the time of printing. Please refer to [www.lincolnelectric.com](http://www.lincolnelectric.com) for any updated information.



**THE LINCOLN ELECTRIC COMPANY**

22801 St. Clair Avenue • Cleveland, OH • 44117-1199 • U.S.A.  
Phone: +1.216.481.8100 • [www.lincolnelectric.com](http://www.lincolnelectric.com)