

DOWN-DRAFT TABLE

DOWN-DRAFT TABLE WITH FAN FOR WELDING AND GRINDING

SAFETY INSTRUCTIONS FOR USE AND MAINTENANCE

N° W000273086 - W000273087



EDITION : EN
REVISION : A
DATE : 10-2022

Instructions for use

REF : **8695 8014**

Original instructions

LINCOLN[®]
ELECTRIC

Thank for the trust you have expressed by purchasing this equipment, which will give you full satisfaction if you follow its instructions for use and maintenance.

Its design, component specifications and workmanship comply with applicable European directives.

Please refer to the enclosed CE declaration to identify the directives applicable to it.

The manufacturer will not be held responsible where items not recommended by themselves are associated with this product.

For your safety, there follows a non-restrictive list of recommendations or requirements, many of which appear in the employment code.

Finally we would ask you kindly to inform your supplier of any error which you may find in this instruction manual.

CONTENTS

A - INTRODUCTION1
 USING THE MANUAL1
 MACHINE GUARANTEE1
 ASSISTANCE1
 DESCRIPTION OF PICTOGRAMS1

B - GENERAL SAFETY INSTRUCTIONS2
 ELECTRICAL SAFETY2
 PERSONAL PROTECTION3
 FILTRATION OF FUMES AND DUST5

C - OVERALL DESCRIPTION6

D - TECHNICAL DESCRIPTION7
 COMPOSITION OF THE ASMV TABLE7
 DIMENSIONS OF THE ASMV TABLE8
 OPERATING PRINCIPLE9

E - INSTALLATION OF THE ASMV TABLE11
 ASSEMBLY11
 PUTTING INTO SERVICE11

F - MAINTENANCE12
 PRE-FILTER13
 ELECTRICAL DIAGRAMS14
 SPARE PARTS15

PERSONAL NOTES16

	ASMV Down-draft table
	DOWN-DRAFT TABLE WITH FAN FOR WELDING AND GRINDING
	TYPE : W000273087 and W000273086

1) CE/UE DECLARATION OF CONFORMITY

Dear customer, This CE/EU declaration of conformity certifies that the supplied equipment complies with applicable laws and regulations when used in accordance with the enclosed instructions. Any other assembly or modification would void our certification. That is why you are asked to call in the manufacturer for any modifications you wish to make. Failing that, the company responsible for the modification must repeat the certification process. In that case, we would not be liable for the new certificate in any way. Please hand this document over to your technical department or purchasing department for filing.

DESCRIPTION	TYPE
Down-draft table for welding and grinding AMSV 1200 x 800	W000273087
Down-draft table for welding and grinding AMSV 2000 x 800	W000273086

NUMBER: See identification plate

2) This equipment complies with European directives.

☐ **N° 2006/42/CE** ☐ **N° 2011/65/UE** ☐ **N° 2014/30/UE**

3) Based on the following harmonised standards:

EN ISO 12100:2010
EN ISO 13850:2008
EN ISO 12499
EN 60204-1

4) Air Treatment Products Manager, authorised to compile the technical manufacturing document.

M. Patrick DEGROOTE
LINCOLN ELECTRIC FRANCE SAS
Avenue Franklin Roosevelt
76120 – LE GRAND QUEVILLY

5) The Manufacturer.

LINCOLN ELECTRIC FRANCE SAS
Avenue Franklin Roosevelt
76120 – LE GRAND QUEVILLY

CERGY, on 29/10/2019



A - INTRODUCTION

USING THE MANUAL

Please read this manual before you start handling, installing or using the machine. Keep the manual safe in a place known to the machine user and maintenance personnel until the machine is finally destroyed.

This manual explains how to transport, install, use and maintain the filter. It cannot in any event replace the experience of the user for operations of varying difficulty.

Before the filter is used by a new user, make sure that they have read this manual and understood all the explanations provided.

For any further information, please feel free to contact the technical departments of **LINCOLN ELECTRIC**.

MACHINE GUARANTEE

This machine is guaranteed for 12 months from the date of purchase.

During the first 12 months of use, defective parts shall be replaced free of charge providing the damage is not the result of improper use of the machine.

The machine guarantee shall cease automatically when the machine is no longer the property of the original buyer.

The terms of validity of the guarantee shall be subject to verification and acceptance by our sales department.

Any nonconforming use that could damage the machine shall not be covered by the guarantee.

For the guarantee to operate, the equipment must be inspected by our technical department.

ASSISTANCE

LINCOLN ELECTRIC is at your disposal for any work on your equipment.

Please send any requests to the technical department.

HOT LINE (+33) 825 132 132

DESCRIPTION OF PICTOGRAMS

To make this document easier to understand, it contains pictograms with the meanings given below :



DANGER: indication used when failure to follow the instructions could lead to a serious hazard for personnel.



WARNING: indication used when failure to follow the instructions could lead to damage to the machine, associated elements or the surroundings.



This symbol shows that the description is intended for specialised personnel.

B - GENERAL SAFETY INSTRUCTIONS

ELECTRICAL SAFETY

Connection to the mains

Before you connect your machine, please make sure that:

- The meter, the overintensity protection system and the electrical installation are compatible with its maximum power rating and its supply voltage.
- It can be connected, in a single-phase or three-phase with earth system, to a socket compatible with the plug on its power cord (mobile equipment).
- If the cable is connected to a fixed point, the earth connection, if there is one, may never be cut off by the system offering protection from electric shocks.
- The switch, if there is one, is set to OFF.

Workstation

Arc welding and cutting requires strict compliance with safety requirements in respect of electrical currents (Order of 14 December 1988).

Working on the machine

Before any internal checking or repairs, make sure that the machine has been disconnected from the electrical system by locking it out:

- Accidental connection of the cable of a fixed system has been made impossible
- Cutting off by means of a fixed connection device relates to all poles (phase and neutral). It must be in the OFF position, with no possibility of being put into service by mistake

Some machines have an HV/HF arc ignition circuit (indicated by a plate). Never work inside such a box.

Any work on electrical systems must be carried out by persons qualified for that purpose (Decree 88-1056 of 14 November 1988, Section VI, Art 46).

Maintenance

From time to time, check that the machinery and its electrical accessories - connectors, flexible cables and extension cords - are correctly insulated and connected.

Work for maintaining and repairing insulating enclosures and ducts may not be carried out in a haphazard manner (Section VI, Art. 47 Decree 88-1056 of 14 November 1988).

- All repairs are to be carried out by specialists, or better yet, defective accessories should be replaced.
- Regularly check that the electrical connections are tight, with no heating.

Any fans placed in a circuit in which the air is laden with dust must be cleaned from time to time. That is because the turbine may be fouled and become unbalanced, leading to increased noise and premature wear and tear of bearings. Maintenance is required at least after every six months, depending on the type of dust treated.

The fan is an essential element of your extraction system.

Incorrect operating or inadequate maintenance could make the operating position less safe. That is why the fan must be maintained in perfect condition.

Your installation has been selected for a specific application. The turbine is characterised by an operating point based on extraction speed (speed of air in the piping) and head loss.

In accordance with the regulations of CARSAT and INRS, the system must be inspected from time to time to make sure that it continues to comply with its reference values.

PERSONAL PROTECTION

Risks of external injury relating to welding operations

Whole body

- The operator must be clothed and protected to suit the requirements of the job.
- Make sure that no part of the bodies of operators and helpers can come in contact with metal pieces or parts that are live or are liable to become live accidentally.
- Do not wind electricity cables around the body.
- Keep safety guards and panels in place.
- The operator must always wear personal insulating protection (Order of 14 December 1988, Section III).
- The protection must be kept dry to prevent electric shocks if it is wet, or ignition in the presence of oil.

Personal protective equipment worn by operators and their helpers - gloves, aprons, safety shoes - offer the added benefit of protecting them from burns due to hot parts, splatter and slag.

Make sure the PPE is in good condition and replace it before it ceases to offer protection.

Face and eyes

It is indispensable to protect the following:

- Eyes, from arc injury (dazzling due to visible light from the arc, and infrared and ultraviolet radiation).
- Hair, face and eyes from welding splatter and projection of slag during weld cooling

The welding mask, when used under or without a helmet, must always be equipped with a protective filter, the shade of which depends on the intensity of the welding arc current (Standards NF S77-104 A 88-221 A88-222).

The coloured filter may be protected from impacts and splatter by a transparent glass located on the front of the mask.

If the filter is replaced, use another one with the same part number (shade number).

Persons in the vicinity of the operator, especially any helpers, must be protected by means of suitable screens, anti-UV goggles or, if needed, masks with suitable protective filters (EN 139).

Specific case of chlorine solvents in welding: (used for cleaning or degreasing).

- The fumes from these solvents can be changed into toxic gases when subjected to arc radiation, including from a distance.
- Such solvents may therefore not be used in locations where electric arcs occur, if the solvents are not in a sealed enclosure.

Work in confined spaces

Examples:

- Mine roads
- Piping and pipelines
- Ship docks, pits, manholes, cellars
- Tanks
- Ballast tanks
- Silos
- Reactors

Special precautions must be taken before undertaking welding operations in such enclosures, where suffocating and poisoning and fire and explosion risks are very great.

A work permit procedure setting out all the safety measures must systematically be set up.

Make sure that ventilation is appropriate, paying special attention to:

- under-oxygenation
- over-oxygenation
- excess fuel gas

FILTRATION OF FUMES AND DUST

Important

Mechanical or electrostatic filtration systems are effective for the filtration of solid but not gaseous particles (exterior discharge).

If recycling is effective (not recommended), make sure the workplace where the machine or machines are placed is properly ventilated, so as to not reach the OELV (occupational exposure limit values) for the specific gaseous pollutants generated by the process (welding, cutting).

Field of use

Filtration of solid particles and dry dust, non-flammable gas, with no risk of explosion.

- Zinc, paper, flour, plant leaves, graphite, aluminium and other such dust is to be excluded, because electrostatic discharge or welding splatter would present a risk for those using the filter.
- The air flow through the filter medium must not be at a temperature above 80 °C.
- This machine is not designed for extracting chemicals.
- The choice of machine is made to suit the pollutants to treat. Extraction at source of the pollutant is only effective if the machine is operating at its nominal power (air flow at the nozzle).

Take particular care to:

- Not obstruct the air outlet of the machine.
- Not introduce external elements into the filter (paper, cloths, cigarette butts etc.)
- Replace the filter medium with new original **LINCOLN ELECTRIC** medium, which alone can guarantee the filtration characteristics.
- Replace the hoses if they are pierced.
- Regularly clean the metal pre-filter on those machines that have one.

Safety alert



CAUTION

Never introduce incandescent particles into the extraction duct.

Example :

- Cigarette butts
- Burning paper
- Incandescent milling particles
- Plasma or air arc gouging particles
- Or any other incandescent product
- List not comprehensive



C - OVERALL DESCRIPTION

For your safety and optimum machine performance, please read this manual carefully before using the equipment.

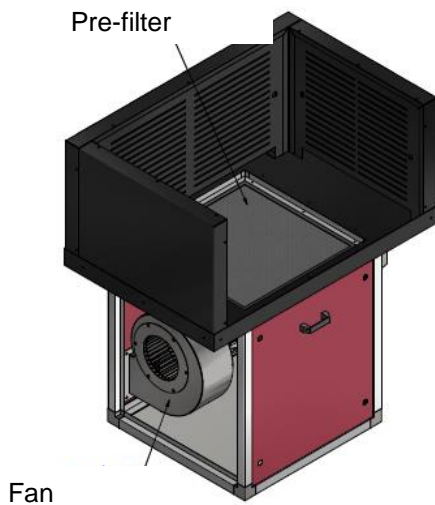

ASMV down-draft tables with fans for welding and grinding are designed to extract **welding** fumes and for occasional grinding work. They have a pre-filter under the work surface.

The table has an extraction fan; fumes and dust are extracted by the table surface and by the three lateral panels.

Discharge is via an outlet adapted at the rear or on the side. An optional discharge silencer is available. Under applicable legislation, the extracted fumes must be discharged outside the building.

It is available in two sizes:

- 1200 x 800 mm
- 2000 x 800 mm

Part numbers

ASMV down-draft table, 1200 x 800 mm	W000273087
ASMV down-draft table, 2000 x 800 mm	W000273086
Rear lateral or vertical outlet, Ø 250 mm	W000342588
Rear lateral or vertical outlet, Ø 250 mm	W000273464
TRC Ø 250 mm for silencer, 1200x800 table	W000380507
TRC Ø 315 mm for silencer, 2000x800 table	W000380508

Benefits:

- Monobloc table with fan
- Rapid commissioning
- Versatile, may be used for TIG, MIG, coated-electrode welding and grinding.
- Fitted with a disconnecting box.

Delivery:

The table is delivered ready to be connected to the duct system and electrically.

D - TECHNICAL DESCRIPTION

COMPOSITION OF THE ASMV TABLE

The table is made up of:

- A table top, 1070 X 740 or 1870 x 740 mm.
- Working height 920 mm.
- Max load capacity of the table: 200 kg.
- Lateral extraction panels, 500 mm high.
- Metal pre-filter, dimensions 610 x 610 x 24 mm.
- Ø250 mm air exit at the rear of the table
- Galvanised steel grating on the table top.
- Noise below 70 dB(A)
- Overall dimensions (L x W x H):
 - 1200 x 800 x 1420 mm
 - 2000 x 800 x 1420 mm
- Fan power: 2.2 kW – 400 V – 3 ph – 50 Hz for both models.
- The extraction rate is:
 - **2000 m³/h** with the 1200 x 800 table
 - **3000 m³/h** with the 2000 x 800 table.

DIMENSIONS OF THE ASMV TABLE

ASMV table, 1200 x 800 mm



ASMV table, 2000 x 800 mm

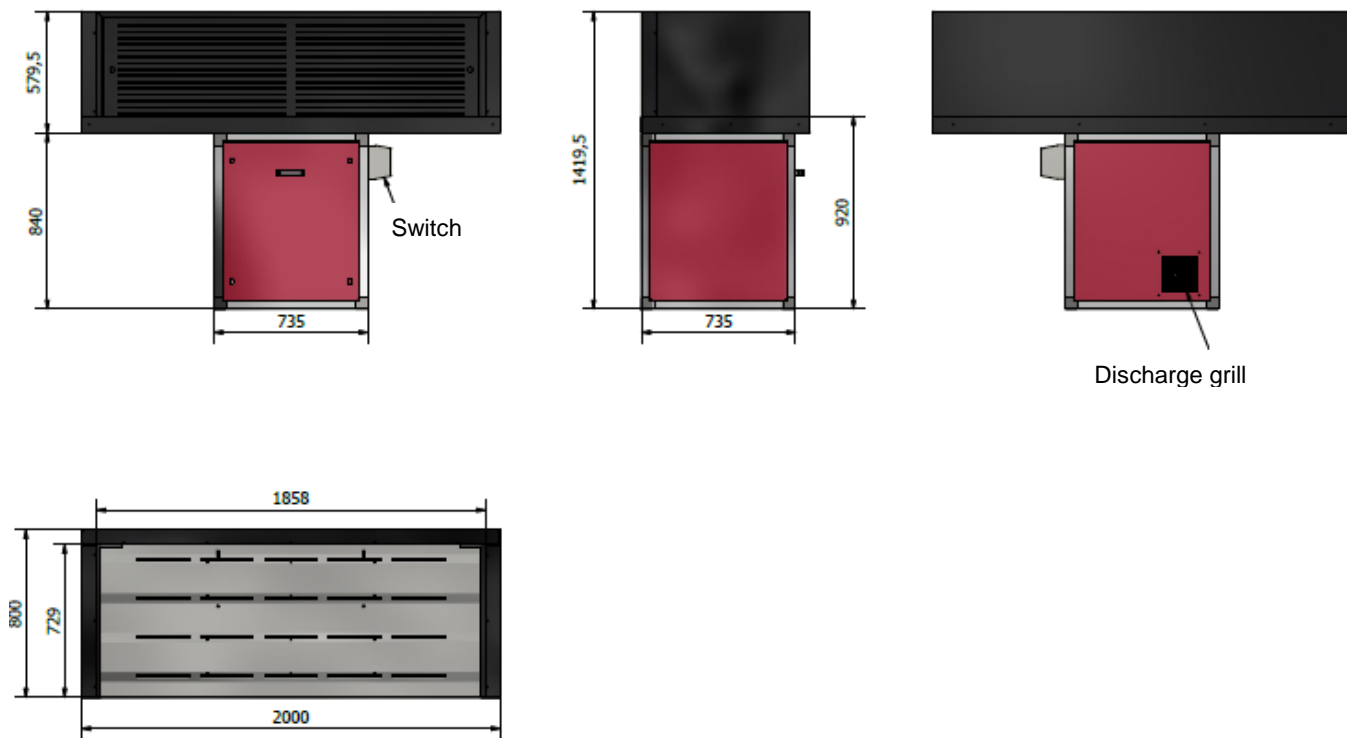

OPERATING PRINCIPLE

When the fan is started up, fumes and dust are extracted in two stages:

1. The fumes first pass through an air flow distribution plate to even the extraction between the work surface and lateral panels and then through the integrated metal pre-filter meeting the EU2 standard and measuring 610 x 610 x 24 mm.
2. The flow is then discharged by the discharge grill located at the rear of the table.

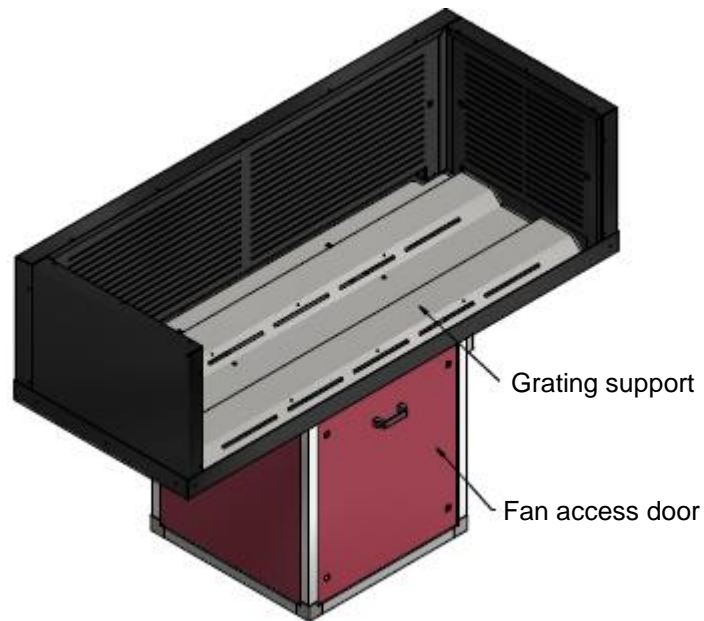

HCAS FAN

- **USE**
HCAS low-pressure centrifugal fans are designed to extract clean air or air with a low dust and fumes content.
- **SPECIFICATIONS OF STANDARD RANGE**
 - Class F MOTOR, IP55, 50Hz, B35, 400V three phase
 - Forward curved type IMPELLER in painted steel
 - Painted steel HOUSING
- **AMBIENT TEMPERATURE**
Temperature between -20°C and +40°C (unless otherwise indicated on the motor identification plate)
- **TEMPERATURE OF TRANSPORTED FLUID**
Temperature between -20°C and +80°C max. depending on surface pressure and temperature (see marking)

Exploded view

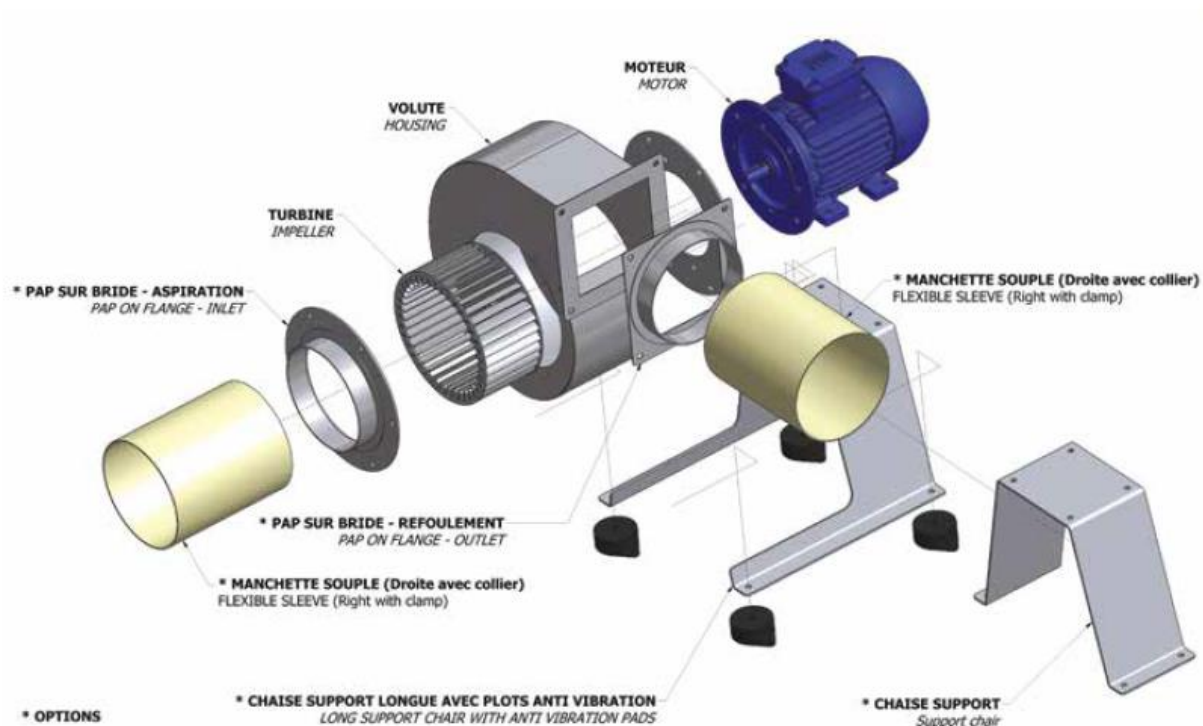

E - INSTALLATION OF THE ASMV TABLE

ASSEMBLY

Move the table with a lift truck to its location, then remove the packaging and transport protection material.

Connect the table to the air extraction duct using \varnothing 250 or 315 mm, for outdoor discharge.

Electricity power must be provided nearby.

PUTTING INTO SERVICE

Mains connection

- Power supply – 400V. – 50 Hz – 3ph.
- Motor power: 2.2 kW for tables 1200 x 800 and 2000 x 800

All the operations relating to the installation, such as those for assembly, installation, putting into service and maintenance, are to be carried out by qualified personnel under the control of a responsible technician.

This equipment must be connected to the distribution system using the original cable.

If you need to extend or change the cable, make sure that the cross section is at least equal to the power cable of the cable (1.5 mm^2).

The power supply must have:

- A device for protecting personnel from indirect hazards:
A 30 mA residual-current circuit-breaker to isolate the machine after it is halted.
- A connector with the earth terminal (compulsory).

Before you make the electrical connections, check that no component has been damaged during transport.



> IMPORTANT :

Before connecting the power, make sure that the machine is out of service (switch set to 0)..

F - MAINTENANCE

Please read the manually carefully before you start any servicing work. Maintenance operations may only be carried out by specialised and qualified individuals. Behaviour that does not comply with the safety instructions provided could lead to major hazards for personnel and damage to property and/or the surroundings.



All routine and/or exceptional maintenance must be carried out with the machine disconnected from the supply system.

Advice for machine users: maintenance is to be carried out as described in the manual.

1. Electrical risks
2. Cutting and abrasion risks in filter area.

Mind the maintenance of the electrical cabinet. Hazards are indicated by a plate saying "HAZARDOUS VOLTAGE".

In order to ensure the proper working of the machine, defective spare parts must be replaced with original spare parts from **LINCOLN ELECTRIC**.



Before starting up the machine, make sure that the replaced parts are perfectly installed and that the tools used are removed from the machine.

Make sure that each safety device is in good condition and legible.

MAINTENANCE OF MECHANICAL PARTS

The machine requires negligible mechanical maintenance if it is used correctly in accordance with its technical characteristics.

Before any type of maintenance that is not clearly defined in these instructions, please make inquiries with the technical department of **LINCOLN ELECTRIC**.

The performance of operations that may not be carried out or are contrary to the standards and procedures described in the manual would release **LINCOLN ELECTRIC** from liability for any damage caused and would void the guarantee if it is still valid.

PRE-FILTER

During pre-filter maintenance, always use protective goggles and a respiratory mask in order to prevent all risks of contact with or inhalation of the particles collected. The power supply must always be switched off using the disconnecter or via the fuses. If the filter has a power connector, it must be separated from its socket on the wall.



Pre-filter cleaning frequency

Maintenance depends on use.

We recommend inspecting the pre-filters after every two weeks at the start, while you determine the actual maintenance frequency.

Then you need to inspect:

- the pre-filter and the fine filter, every month,
- The pre-filter must be cleaned every month.

PRINCIPLE:

For access to the pre-filter, the grating must be removed.

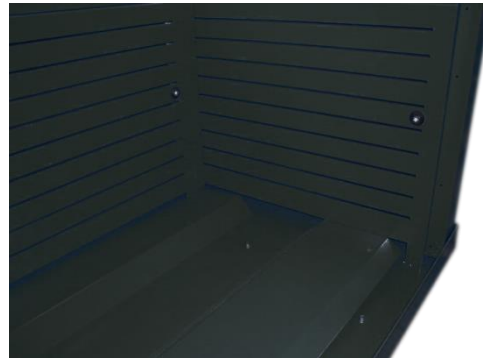

Cleaning the mechanical pre-filter

- Use FILTER FILTERCLEAN cleaner, part no W000342878.
- Dilute FILTER FILTERCLEAN cleaner in water Part no W000342878. (15 or 20%)
- Leave for about 10 minutes.
- Clean with clean water, dry.



In no event may the machine be used without a pre-filter or with a pre-filter that is not the same as the original from LINCOLN ELECTRIC.

ELECTRICAL DIAGRAMS

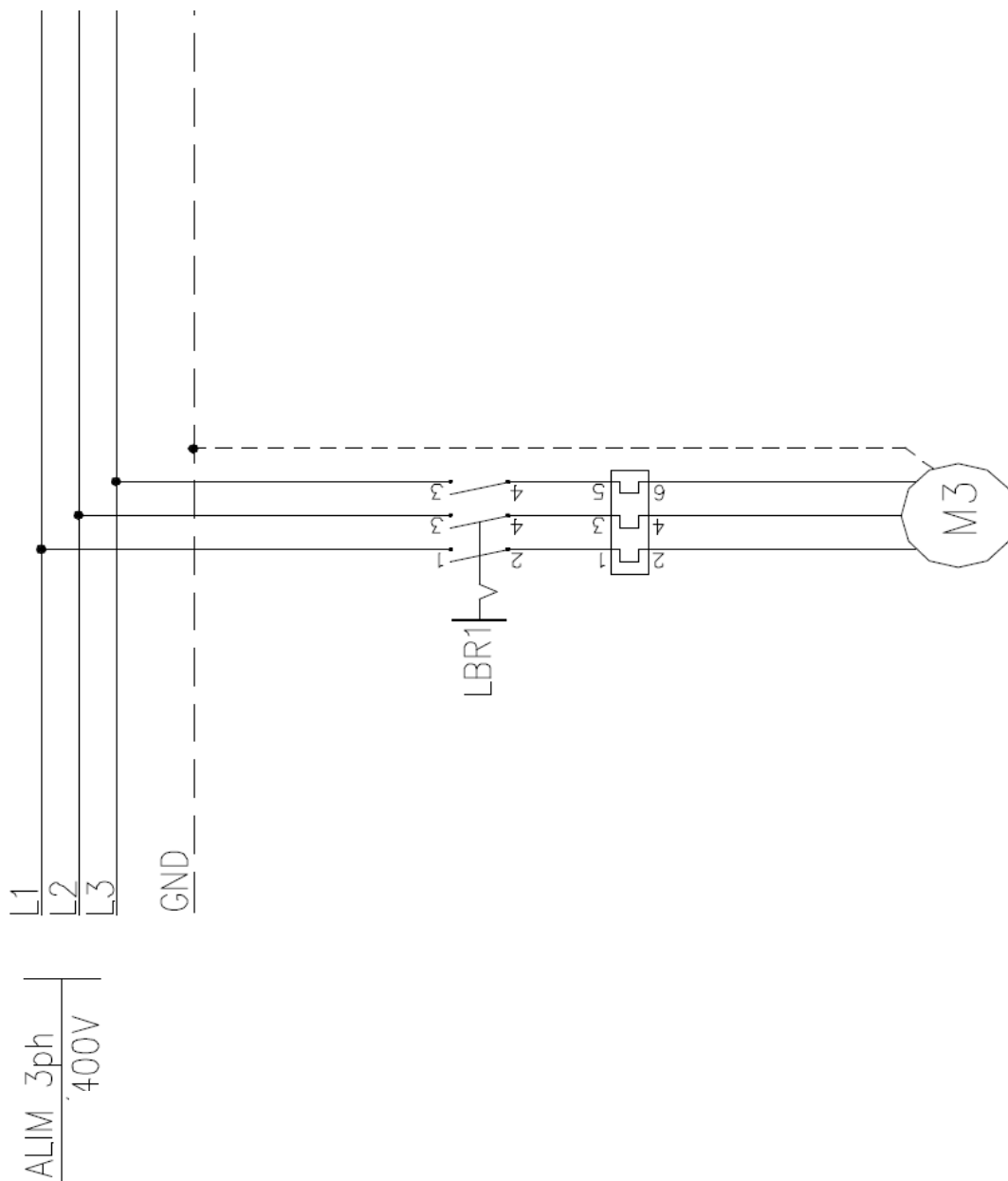

SPARE PARTS

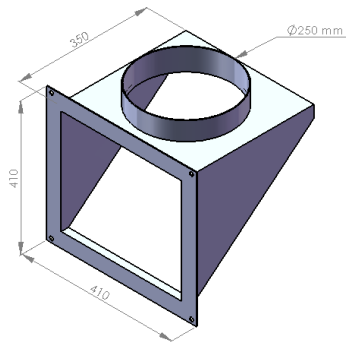

Description	Part number	Quantity
Lateral or rear vertical table outlet, 250 mm	W000342588	1
Vertical outlet with silencer box	W000273464	1
TRC Ø250 mm, 1200 x 800 mm table	W000380507	1
TRC Ø315 mm, 2000 x 800 mm table	W000380508	1
Metal pre-filter (610 x 610 x 24) mm	W000379636	1
Thermal magnetic circuit breaker	W000342525	1
HCAS 240 fan- 2 poles - 2.2 kW	EM61000515	1
Motor, 2 poles – 2.2 kW - T- B35- IE3	EM61000513	1
HCAS 240 x 90 impeller- AI 24- A - LG	EM61000514	1

