

SPEEDTEC® 400SP & 500SP

Spare Parts	1
Figure A: Machine Assembly	2
Figure B: Inside Machine Assembly	3
Figure C: Front Assembly	5
Figure D: Rear Assembly	6
Miscellaneous Items (not shown in figure A, B, C, D)	6
Electrical Schematic	7
CODE: 50593, 50594	7
CODE: 50590, 50591	8



Spare Parts

50593, 50594, 50590, 50591 REV04
03/2023

ASSEMBLY PAGE NAME			Machine Assembly	Machine Assembly	Machine Assembly	Miscellaneous Items		
CODE NO.:	K NO.:	FIGURE NO.:	A	B	C	-		
50593	K14258-1	SPEEDTEC® 400SP	1	1	1	1		
50594	K14259-1	SPEEDTEC® 500SP	2	2	2	2		
50590	K14258-2	SPEEDTEC® 400SP (VRD)	3	3	3	3		
50591	K14259-2	SPEEDTEC® 500SP (VRD)	4	4	4	4		

*Items highlighted in bold are recommended spare parts

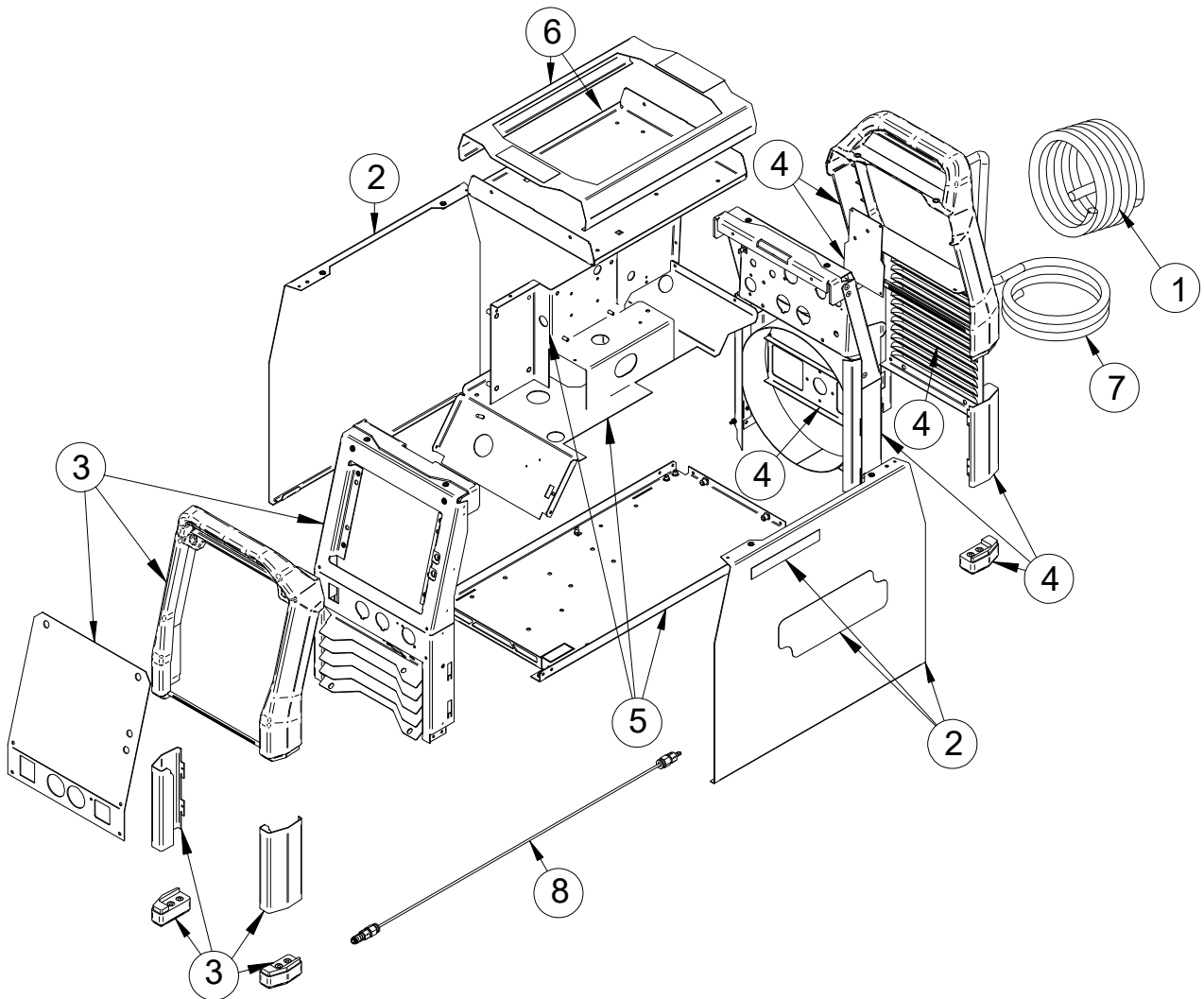

Figure A

Figure A: Machine Assembly

Item	Description	Part Number	QTY	1	2	3	4	5	6	7
1	WELDING CABLE	R-5041-024-2R	1	X	X	X	X			
2	SIDE PANEL KIT includes:	T-8040-103-1R	1	X	X	X	X			
	SIDE PANEL		2	X	X	X	X			
	LINCOLN ELECTRIC SIDE LABEL		2	X	X	X	X			
	SPEEDTEC® LABEL		2	X	X	X	X			
	5 – YERS WARRANTY LABEL		1	X	X	X	X			
3	FRONT PANEL KIT includes:	T-8040-104-1R	1	X	X	X	X			
	COVER		1	X	X	X	X			
	FRONT PANEL ASSEMBLY		1	X	X	X	X			
	FRONT HANDLE CASE COMPLETE		1	X	X	X	X			
	RIGHT COVER		1	X	X	X	X			
	LEFT COVER		1	X	X	X	X		-	
	RIGHT FOOT		1	X	X	X	X			
	LEFT FOOT		1	X	X	X	X	-	-	
4	REAR PANEL KIT includes:	T-8040-105-1R	1	X	X	X	X			
	BACK PANEL ASSEMBLY		1	X	X	X	X			
	COVER		1	X	X	X	X			
	COVER		1	X	X	X	X			
	BRACKET		1	X	X	X	X			
	FRONT HANDLE CASE COMPLETE		1	X	X	X	X			
	RIGHT COVER		1	X	X	X	X			
	LEFT COVER		1	X	X	X	X			
	RIGHT FOOT		1	X	X	X	X			
	LEFT FOOT		1	X	X	X	X			
	5		BASE, PARTITION, SHELF KIT includes:	T-8040-106-1R	1	X	X	X	X	
BASE ASSEMBLY		1	X		X	X	X			
SHELF ASSEMBLY		1	X		X	X	X			
PARTITION		1	X		X	X	X			
LABEL		1	X		X	X	X			
6	COVER KIT includes:	T-8040-107-1R	1	X	X	X	X			
	COVER		1	X	X	X	X			
	COVER		1	X	X	X	X			
	LABEL		1	X	X	X	X			
	LABEL		1	X	X	X	X			
	LABEL		1	X	X	X	X			
7	POWER LEAD (5m)	D-5578-171-2R	1	X	X	X	X			
8	GAS CONNECTION KIT includes:	T-8040-133-1R	1	X	X	X	X			
	HOSE CARRIER		2	X	X	X	X			
	POLYURETHANE TUBE		1	X	X	X	X			
	BRASS QUICK CONNECT COUPLING		1	X	X	X	X			
	BRASS QUICK CONNECTOR		1	X	X	X	X			

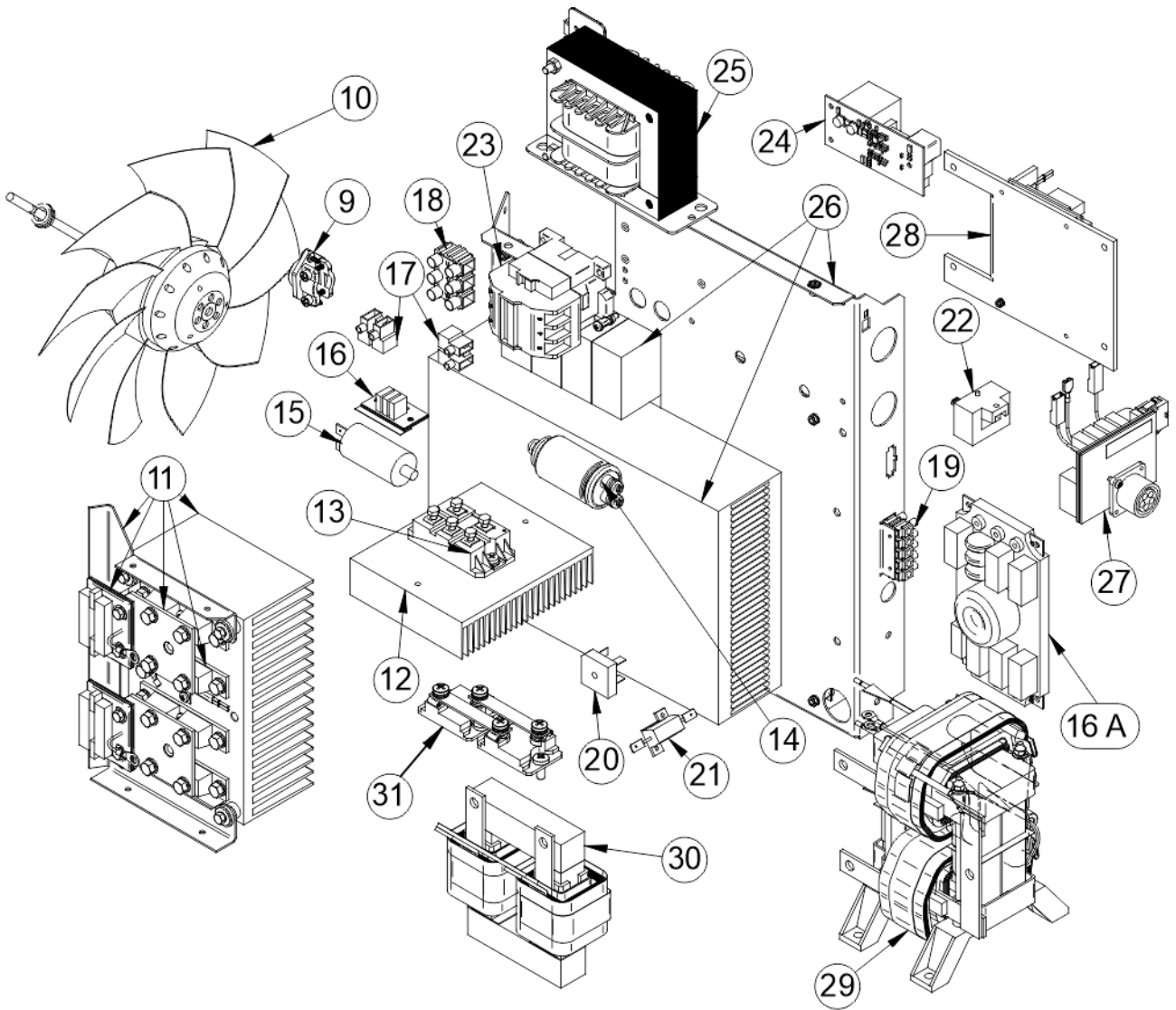

Figure B

Figure B: Inside Machine Assembly

Item	Description	Part Number	QTY	1	2	3	4	5	6	7
9	STRAIN RELIEF	1361-599-674R	1	X	X	X	X			
10	FAN ASSEMBLY KIT	T-8040-108-1R	1	X	X	X	X			
11	OUTPUT RECTIFIER KIT includes:	T-8040-109-1R	1	X	X	X	X			
	ALUMINIUM PROFILE KE190		1	X	X	X	X			
	DIODE MODULE DKR200AB60		4	X	X	X	X			
	BRACKET		1	X	X	X	X			
	LEAD		2	X	X	X	X			
	PC BOARD ASSEMBLY		2	X	X	X	X			
12	INPUT RECTIFIER HEATSINK	R-0000-287-1R	1	X	X	X	X			
13	INPUT RECTIFIER V1	W4100021R	1	X	X	X	X			
14	CAPACITOR 2200U/100VDC	1158-125-329R	1	X	X	X	X			
15	CAPACITOR TC886JS 3UF/K	1158-121-046R	1	X	X	X	X			
16	FILTER	R-8040-361-1R	1	X	X	X	X			
16A	EMC FILTER PC BOARD UFS-1	0918-432-105R	1	X	X	X	X			
17	TERMINAL BLOCK LZW B-4	1131-990-022R	2	X	X	X	X			
18	TERMINAL BLOCK TLZ-10 12T	1131-990-011R	3	X	X	X	X			

19	TERMINAL BLOCK	1131-990-005R	5	X	X	X	X		-	
20	RECTIFIER BRIDGE KBPC5006F	1156-112-100R	1	X	X	X	X			
21	RESISTOR 12R/25W	1158-112-702R	1	X	X	X	X			
22	TRANSF. 500A-4V	90000389PR	1	X	X	X	X			
23	CONTACTOR	R-8040-502-1R	1	X	X	X	X			
24	SPEEDTEC® 410/510SP GREEN MODE PCB	Y081-1R	1	X	X	X	X			
25	AUX. TRANSFORMER-SPEEDTEC®	R-4034-160-2R	1	X	X	X	X			
26	PC BOARD ASSEMBLY includes:	T-8040-110-1R	1		X					
	HEATSINK		1		X					
	SWITCH BOARD		1		X					
	PARTITION ASSEMBLY		1		X					
26	PC BOARD ASSEMBLY includes:	T-8040-110-2R	1	X						
	HEATSINK		1	X						
	SWITCH BOARD		1	X						
	PARTITION ASSEMBLY		1	X						
26	PC BOARD ASSEMBLY includes:	T-8040-110-3R	1				X			
	HEATSINK		1				X			
	SWITCH BOARD		1				X			
	PARTITION ASSEMBLY		1				X			
26	PC BOARD ASSEMBLY includes:	T-8040-110-4R	1				X			
	HEATSINK		1				X			
	SWITCH BOARD		1				X			
	PARTITION ASSEMBLY		1				X			
27	P.C. BOARD (FILTER OUTPUT)	R-8040-339-2R	1	X	X	X	X			
28	BUS 40V DC	R-8040-348-1R	1	X	X	X	X			
29	TRANSFORMER SPEEDTEC®	R-4034-184-1R	1	X	X	X	X			
30	CHOKE	R-4034-181-1R	1	X	X	X	X			
31	RESISTOR VRD ASSEMBLY KIT:	T-8040-131-1R	1			X	X			
	RESISTOR 100OHM 100W		2			X	X			
	COPPER BAR		2			X	X			
	SCREW M4x8 PH2 NiPL		4			X	X			

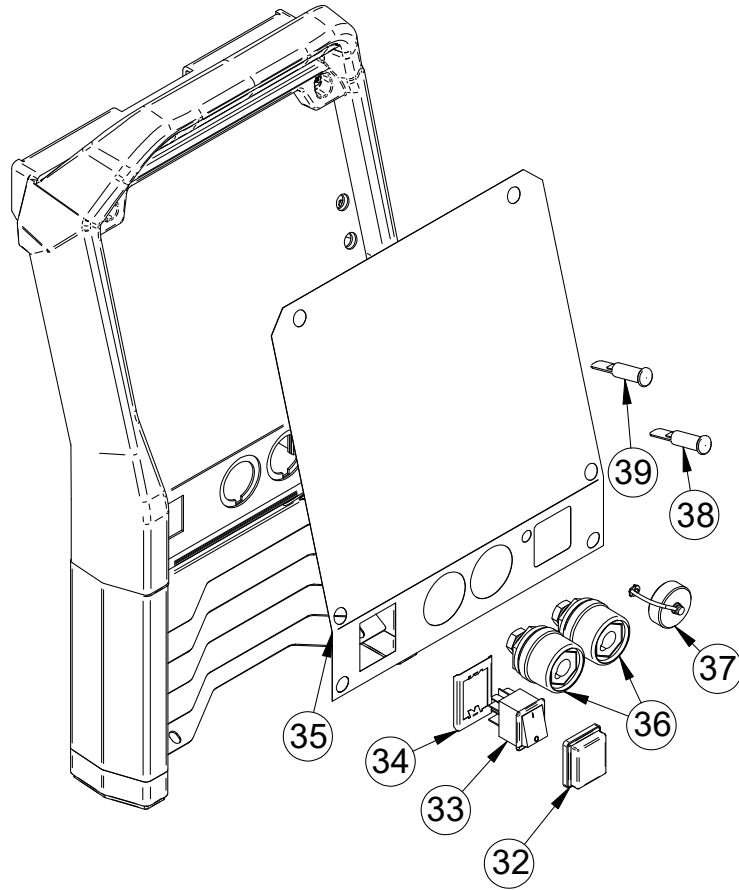

Figure C

Figure C: Front Assembly

Item	Description	Part Number	QTY	1	2	3	4	5	6	7
32	SWITCH COVER AND BEZEL	1115-299-073R	1	X	X	X	X			
33	MAIN SWITCH	1115-270-022R	1	X	X	X	X			
34	INTERLOCK	D-2722-029-1R	1	X	X	X	X			
35	FRONT LABEL	R-0000-284-1R	1		X					
	FRONT LABEL	R-0000-284-2R	1	X						
	FRONT LABEL	R-0000-284-3R	1				X			
	FRONT LABEL	R-0000-284-4R	1			X				
36	SOCKET	90000595PR	2	X	X	X	X			
37	PROTECTION COVER PLUG AMP	1158-641-128R	1	X	X	X	X			
38	LAMP GREEN/RED LSN.1/D13	0917-421-009R	1	X	X	X	X			
39	LAMP WHITE LS-3-N1	0917-421-043R	1	X	X					
	LAMP GREEN/RED LSN.1/D13	0917-421-009R	1			X	X			

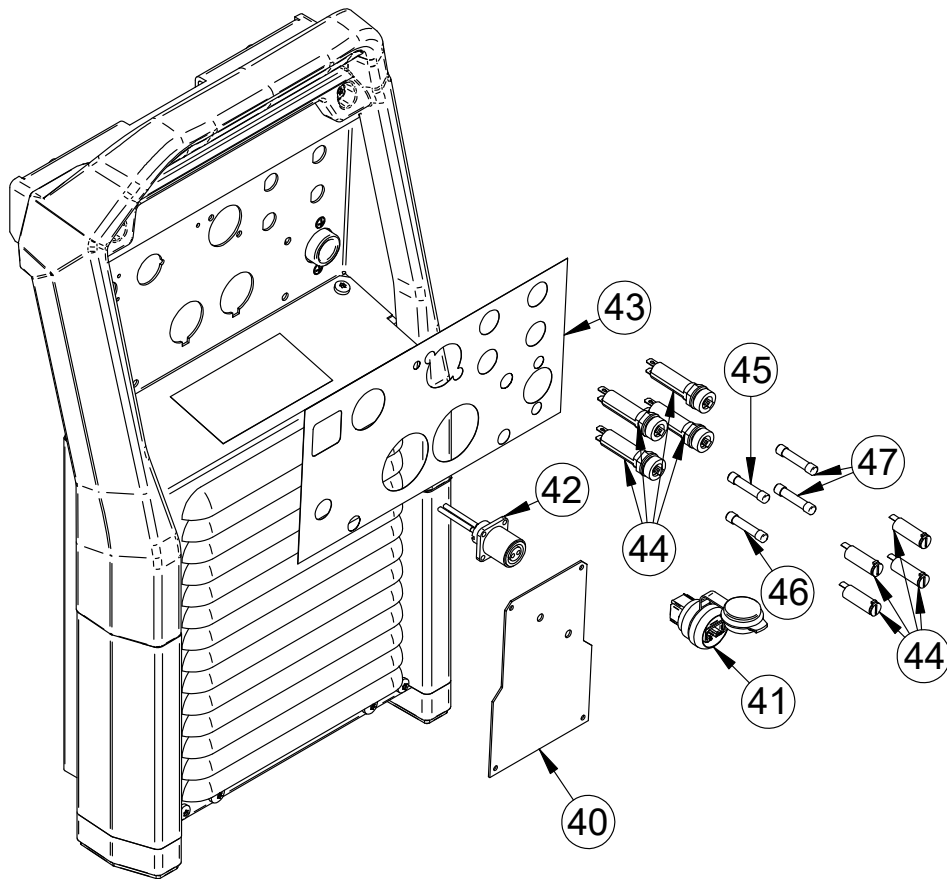

Figure D

Figure D: Rear Assembly

Item	Description	Part Number	QTY	1	2	3	4	5	6	7
40	COVER	R-1019-680-1R	1	X	X	X	X			
41	ETHERNET SOCKET	1159-190-070R	1	X	X	X	X			
42	GAS HEATER WIRING	R-5041-141-1R	1	X	X	X	X			
43	LABEL	R-0000-281-1R	1	X	X	X	X			
44	FUSE HOLDER + FUSE CAP	1158-632-032R	4	X	X	X	X			
45	FUSE 12,5A 6,3X32 ZGT	1158-660-012R	1	X	X	X	X			
46	FUSE 6,3X32 6,3A 400V WB-C	1158-660-008R	1	X	X	X	X			
47	FUSE 6.3X32 2A 400V WB-CT	1158-660-010R	2	X	X	X	X			

Miscellaneous Items (not shown in figure A, B, C, D)

Item	Description	Part Number	QTY	1	2	3	4	5	6	7
48	HARNESSES KIT	T-8040-111-1R	1	X	X					
	HARNESSES KIT	T-8040-132-1R	1			X	X			

Electrical Schematic

CODE: 50593, 50594

