

FAB-PAK XHS-RM

ROBOTIC WELDING SYSTEMS

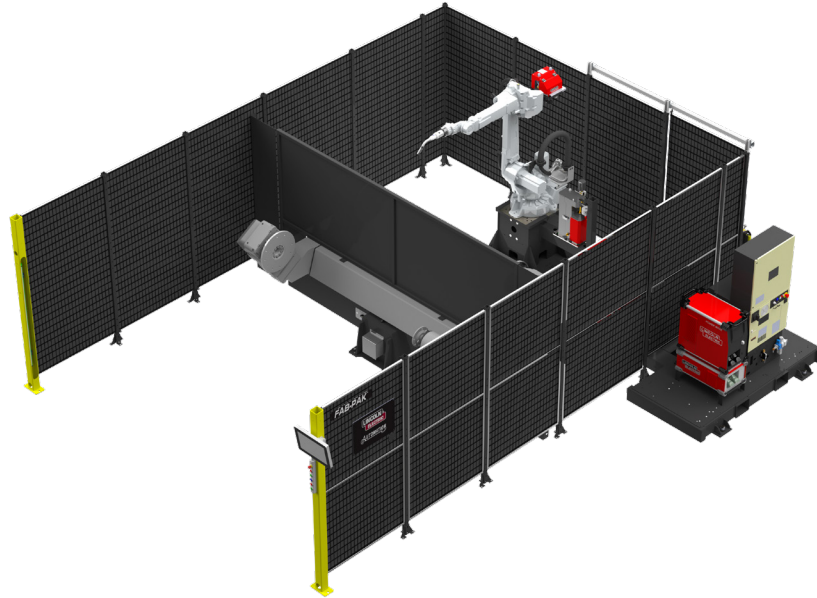

Renders are for reference only

FAB-PAK XHS-RM (INDEXING HEADSTOCK REAR-MOUNT) ROBOTIC WELDING SYSTEM

The Fab-Pak® family of pre-engineered robotic welding systems from Lincoln Electric Automation™ enhance part production by helping to improve productivity, quality, and safety. The Fab-Pak XHS-RM standard robotic welding system is ideal for parts up to 1000kg that need reorientation.

SYSTEM INCLUDES

- Power Wave® R450 power source
- AutoDrive® 4R220 wire feeder
- Magnum® PRO robotic torch
- Power Ream® II torch maintenance unit
- Servo-driven H-Frame indexing unit
- ABB® welding robot
- Basic robot software package
- Wire mesh panels with weld curtains
- Push button control

KEY FEATURES

- Single load/unload access point
- Headstock/tailstock positioner in each zone

INDUSTRY

- High-mix, low-volume manufacturing

BENEFITS

- Helps increase throughput efficiency, accuracy, and repeatability
- Easily configurable for future production flexibility
- ANSI/RIA safety compliant

OPTIONS AVAILABLE

- Water-cooled torch
- Touch sensing software
- Laser touch sensing add-on hardware (requires water-cooled torch)
- Thru-Arc™ Seam Tracking
- Touch-screen HMI
- Fume filtration
- Tooling tables and beams
- Single-panel fencing
- In-person training

CONTACT LINCOLN ELECTRIC AUTOMATION - CLEVELAND



22221 St. Clair Ave
Euclid, OH 44117



+1 [216] 383-2959



lincolnelectric.com/fab-pak

Publication LEA-011824TM3-01

© Lincoln Global Inc. All Rights Reserved. All trademarks and registered trademarks are the property of their respective owners.
www.lincolnelectric.com/automation



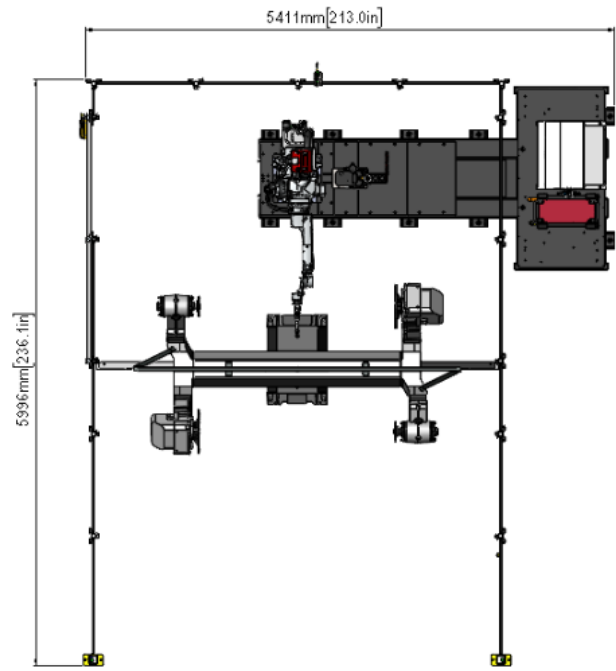
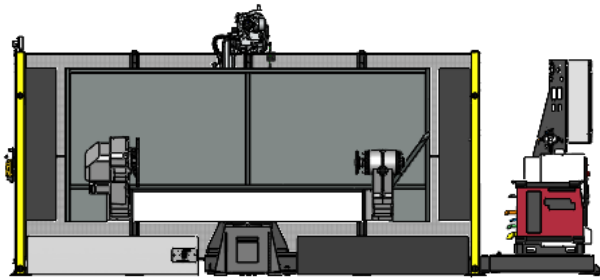
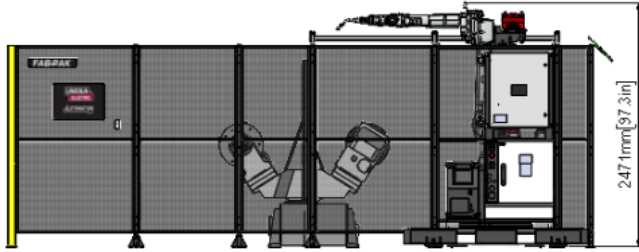

Fab-Pak XHS-RM 2000mm system with ABB robot

PRODUCT SPECIFICATIONS

Product Number	Model Name	Positioner Capacity (kg)	Span (mm)	Swing (mm)	Wire Feeder	Robot Arm	Qty of Robots
AD2510	XHS-RM 2000mm	1000	2000	1250	4R220	ABB	1
Custom		Based on Customer Specifications					

Important Note: Changes from recommended motor sizing, payload, duty cycles, cable routing, weld grounding (if applicable), other system specifications (i.e. servo parameters, controller stop parameter), and/or modifications may affect cycle times and overall performance. User assumes all responsibility for proper rigging, installation, and machine setting alignments of product(s). Manufacturer's warranty is void to the extent any failure caused by improper installation, modification, or operation by customer.

CUSTOMER ASSISTANCE POLICY

The business of Lincoln Electric is manufacturing and selling high quality welding equipment, automated welding systems, consumables, and cutting equipment. Our challenge is to meet the needs of our customers, who are experts in their fields, and to exceed their expectations. On occasion, purchasers may ask Lincoln Electric for information or technical information about their use of our products. Our employees respond to inquiries to the best of their ability based on information and specifications provided to them by the customers and the knowledge they may have concerning the application. Our employees, however, are not in a position to verify the information provided or to evaluate the engineering requirements for the particular weldment, or to provide engineering advice in relation to a specific situation or application. Accordingly, Lincoln Electric does not warrant or guarantee or assume any liability with respect to such information or communications. Moreover, the provision of such information or technical information does not create, expand, or alter any warranty on our products. Any express or implied warranty that might arise from the information or technical information, including any implied warranty of merchantability or any warranty of fitness for any customers' particular purpose or any other equivalent or similar warranty is specifically disclaimed.

Lincoln Electric is a responsive manufacturer, but the definition of specifications, and the selection and use of specific products sold by Lincoln Electric is solely within the control of, and remains the sole responsibility of the customer. Many variables beyond the control of Lincoln Electric affect the results obtained in applying these types of fabrication methods and service requirements.