

WIRELESS REMOTE CONTROL MACHINE SCHEMATIC L16344-3 REV: A

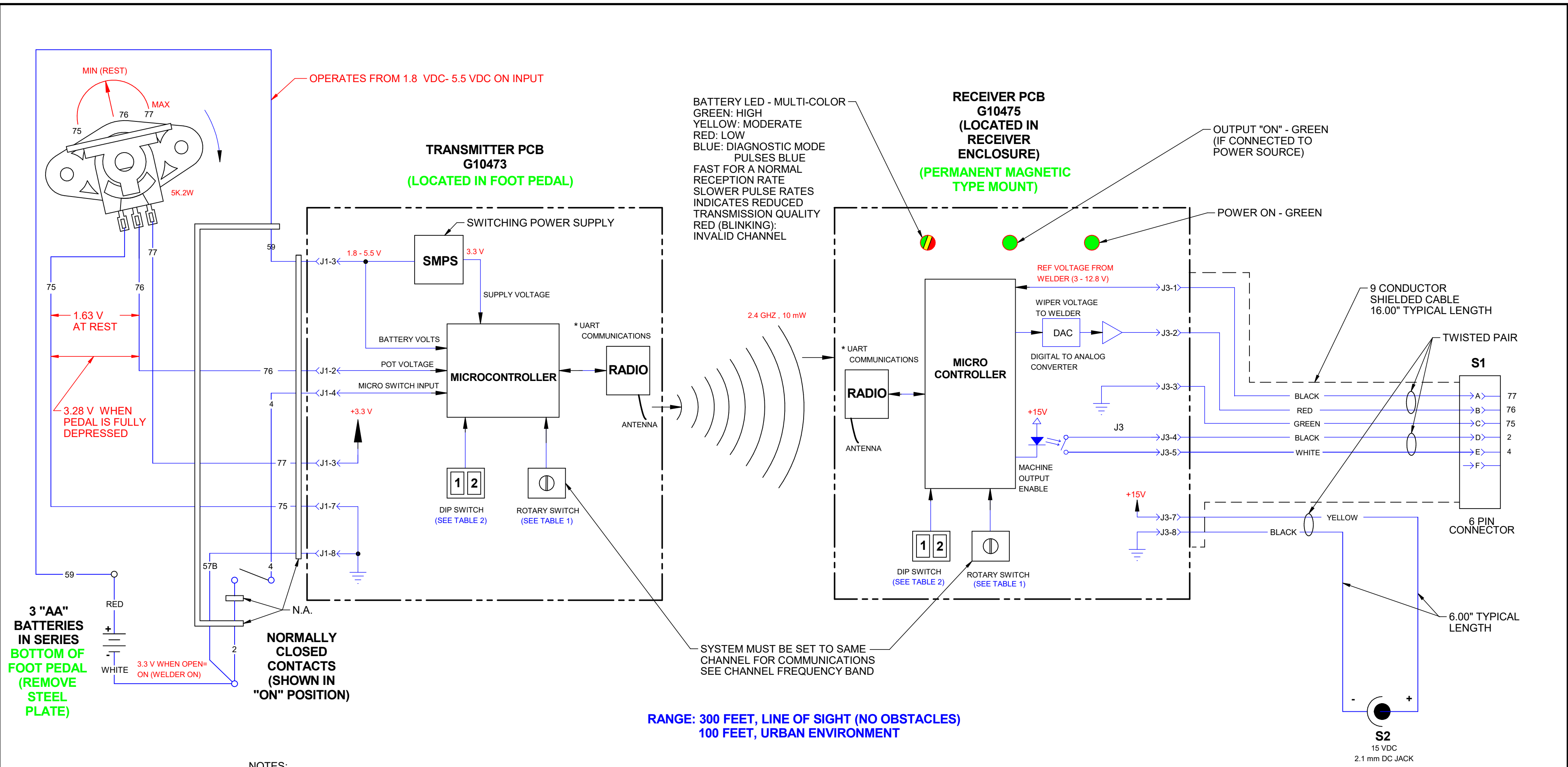

NOTES:
N.A. TOROIDS APPEAR ON UNITS ABOVE CODES 12600.

CHANNEL FREQUENCY BAND
TABLE 1

Channel	Center Frequency* (GHz)
0	2.410
1	2.415
2	2.420
3	2.425
4	2.430
5	2.435
6	2.440
7	2.445
8	2.450
9	2.455
A	2.460
B	2.465
C	2.470
D	2.475
E	2.405

*802.15.4 STANDARD

DIP SWITCH SETTINGS
TABLE 2

Mode of Operation	PCB				Details/Function
	Transmitter		Receiver		
	dip #1	dip #2	dip #1	dip #2	
Control	off	off	off	off	Normal Transmission
Diagnostic	off	off	off	on	Communication strength metric
Config	on	x	on	x	Ensure dip #1 on Transmitter also set
Calibration	x	on	x	x	Set/Clear dip at maximum stroke
Config	on	x	x	x	Ensure dip #1 on Receiver also set
					x = Don't Care

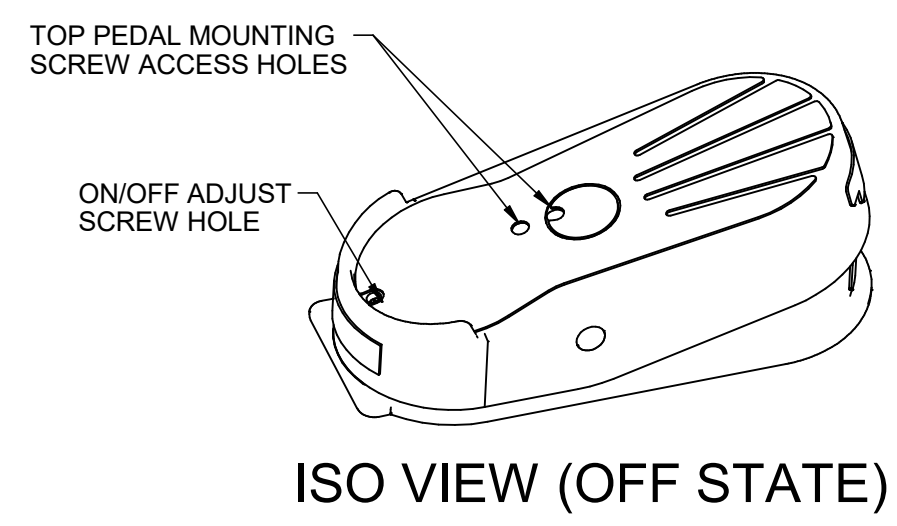

* UART = UNIVERSAL ASYNCHRONOUS RECEIVER/TRANSMITTER/INPUT POWER FOR RECEIVER
115 VAC TO 15 VDC TRANSFORMER AND SUPPLY (M24889)

