

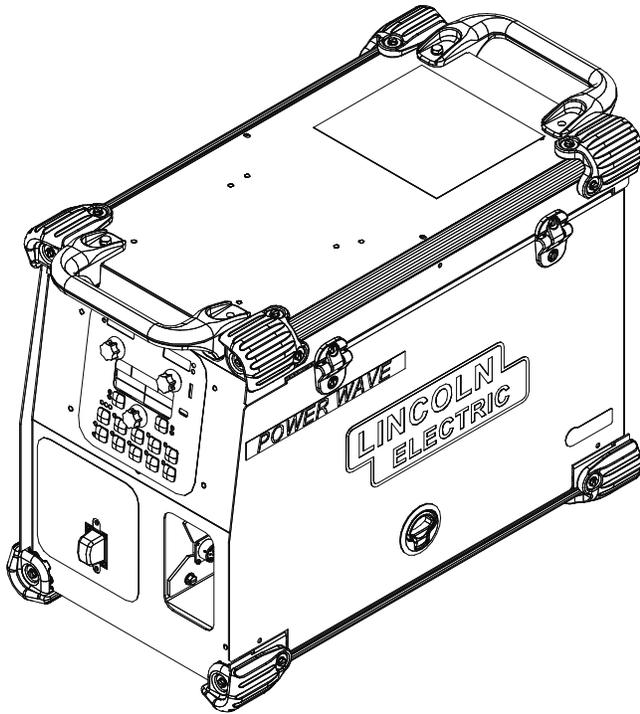

Operator's Manual

POWER WAVE[®] C300 CE



For use with machines having Code Numbers:
11624, 12540, 12756



Register your machine:

www.lincolnelectric.com/register

Authorized Service and Distributor Locator:

www.lincolnelectric.com/locator

Save for future reference

Date Purchased

Code: (ex: 10859)

Serial: (ex: U1060512345)

THANK YOU FOR SELECTING A QUALITY PRODUCT BY LINCOLN ELECTRIC.

PLEASE EXAMINE CARTON AND EQUIPMENT FOR DAMAGE IMMEDIATELY

When this equipment is shipped, title passes to the purchaser upon receipt by the carrier. Consequently, claims for material damaged in shipment must be made by the purchaser against the transportation company at the time the shipment is received.

SAFETY DEPENDS ON YOU

Lincoln arc welding and cutting equipment is designed and built with safety in mind. However, your overall safety can be increased by proper installation ... and thoughtful operation on your part. **DO NOT INSTALL, OPERATE OR REPAIR THIS EQUIPMENT WITHOUT READING THIS MANUAL AND THE SAFETY PRECAUTIONS CONTAINED THROUGHOUT.** And, most importantly, think before you act and be careful.

WARNING

This statement appears where the information must be followed exactly to avoid serious personal injury or loss of life.

CAUTION

This statement appears where the information must be followed to avoid minor personal injury or damage to this equipment.



KEEP YOUR HEAD OUT OF THE FUMES.

DON'T get too close to the arc. Use corrective lenses if necessary to stay a reasonable distance away from the arc.

READ and obey the Safety Data Sheet (SDS) and the warning label that appears on all containers of welding materials.

USE ENOUGH VENTILATION or exhaust at the arc, or both, to keep the fumes and gases from your breathing zone and the general area.

IN A LARGE ROOM OR OUTDOORS, natural ventilation may be adequate if you keep your head out of the fumes (See below).

USE NATURAL DRAFTS or fans to keep the fumes away from your face.

If you develop unusual symptoms, see your supervisor. Perhaps the welding atmosphere and ventilation system should be checked.



WEAR CORRECT EYE, EAR & BODY PROTECTION

PROTECT your eyes and face with welding helmet properly fitted and with proper grade of filter plate (See ANSI Z49.1).

PROTECT your body from welding spatter and arc flash with protective clothing including woolen clothing, flame-proof apron and gloves, leather leggings, and high boots.

PROTECT others from splatter, flash, and glare with protective screens or barriers.

IN SOME AREAS, protection from noise may be appropriate.

BE SURE protective equipment is in good condition.

Also, wear safety glasses in work area **AT ALL TIMES.**



SPECIAL SITUATIONS

DO NOT WELD OR CUT containers or materials which previously had been in contact with hazardous substances unless they are properly cleaned. This is extremely dangerous.

DO NOT WELD OR CUT painted or plated parts unless special precautions with ventilation have been taken. They can release highly toxic fumes or gases.

Additional precautionary measures

PROTECT compressed gas cylinders from excessive heat, mechanical shocks, and arcs; fasten cylinders so they cannot fall.

BE SURE cylinders are never grounded or part of an electrical circuit.

REMOVE all potential fire hazards from welding area.

ALWAYS HAVE FIRE FIGHTING EQUIPMENT READY FOR IMMEDIATE USE AND KNOW HOW TO USE IT.



SECTION A: WARNINGS



CALIFORNIA PROPOSITION 65 WARNINGS



WARNING: Breathing diesel engine exhaust exposes you to chemicals known to the State of California to cause cancer and birth defects, or other reproductive harm.

- Always start and operate the engine in a well-ventilated area.
- If in an exposed area, vent the exhaust to the outside.
- Do not modify or tamper with the exhaust system.
- Do not idle the engine except as necessary.

For more information go to www.P65warnings.ca.gov/diesel

WARNING: This product, when used for welding or cutting, produces fumes or gases which contain chemicals known to the State of California to cause birth defects and, in some cases, cancer. (California Health & Safety Code § 25249.5 *et seq.*)



WARNING: Cancer and Reproductive Harm
www.P65warnings.ca.gov

ARC WELDING CAN BE HAZARDOUS. PROTECT YOURSELF AND OTHERS FROM POSSIBLE SERIOUS INJURY OR DEATH. KEEP CHILDREN AWAY. PACEMAKER WEARERS SHOULD CONSULT WITH THEIR DOCTOR BEFORE OPERATING.

Read and understand the following safety highlights. For additional safety information, it is strongly recommended that you purchase a copy of "Safety in Welding & Cutting - ANSI Standard Z49.1" from the American Welding Society, P.O. Box 351040, Miami, Florida 33135 or CSA Standard W117.2. A Free copy of "Arc Welding Safety" booklet E205 is available from the Lincoln Electric Company, 22801 St. Clair Avenue, Cleveland, Ohio 44117-1199.

BE SURE THAT ALL INSTALLATION, OPERATION, MAINTENANCE AND REPAIR PROCEDURES ARE PERFORMED ONLY BY QUALIFIED INDIVIDUALS.



FOR ENGINE POWERED EQUIPMENT.

- Turn the engine off before troubleshooting and maintenance work unless the maintenance work requires it to be running.
- Operate engines in open, well-ventilated areas or vent the engine exhaust fumes outdoors.
- Do not add the fuel near an open flame welding arc or when the engine is running. Stop the engine and allow it to cool before refueling to prevent spilled fuel from vaporizing on contact



with hot engine parts and igniting. Do not spill fuel when filling tank. If fuel is spilled, wipe it up and do not start engine until fumes have been eliminated.

- Keep all equipment safety guards, covers and devices in position and in good repair. Keep hands, hair, clothing and tools away from V-belts, gears, fans and all other moving parts when starting, operating or repairing equipment.
- In some cases it may be necessary to remove safety guards to perform required maintenance. Remove guards only when necessary and replace them when the maintenance requiring their removal is complete. Always use the greatest care when working near moving parts.
- Do not put your hands near the engine fan. Do not attempt to override the governor or idler by pushing on the throttle control rods while the engine is running.
- To prevent accidentally starting gasoline engines while turning the engine or welding generator during maintenance work, disconnect the spark plug wires, distributor cap or magneto wire as appropriate.
- To avoid scalding, do not remove the radiator pressure cap when the engine is hot.
- Using a generator indoors CAN KILL YOU IN MINUTES.
- Generator exhaust contains carbon monoxide. This is a poison you cannot see or smell.
- NEVER use inside a home or garage, EVEN IF doors and windows are open.
- Only use OUTSIDE and far away from windows, doors and vents.
- Avoid other generator hazards. READ MANUAL BEFORE USE.



ELECTRIC AND MAGNETIC FIELDS MAY BE DANGEROUS



- Electric current flowing through any conductor causes localized Electric and Magnetic Fields (EMF). Welding current creates EMF fields around welding cables and welding machines
- EMF fields may interfere with some pacemakers, and welders having a pacemaker should consult their physician before welding.
- Exposure to EMF fields in welding may have other health effects which are now not known.
- All welders should use the following procedures in order to minimize exposure to EMF fields from the welding circuit:
 - Route the electrode and work cables together - Secure them with tape when possible.
 - Never coil the electrode lead around your body.
 - Do not place your body between the electrode and work cables. If the electrode cable is on your right side, the work cable should also be on your right side.
 - Connect the work cable to the workpiece as close as possible to the area being welded.
 - Do not work next to welding power source.



ELECTRIC SHOCK CAN KILL.



- 3.a. The electrode and work (or ground) circuits are electrically “hot” when the welder is on. Do not touch these “hot” parts with your bare skin or wet clothing. Wear dry, hole-free gloves to insulate hands.
- 3.b. Insulate yourself from work and ground using dry insulation. Make certain the insulation is large enough to cover your full area of physical contact with work and ground.

In addition to the normal safety precautions, if welding must be performed under electrically hazardous conditions (in damp locations or while wearing wet clothing; on metal structures such as floors, gratings or scaffolds; when in cramped positions such as sitting, kneeling or lying, if there is a high risk of unavoidable or accidental contact with the workpiece or ground) use the following equipment:

- Semiautomatic DC Constant Voltage (Wire) Welder.
 - DC Manual (Stick) Welder.
 - AC Welder with Reduced Voltage Control.
- 3.c. In semiautomatic or automatic wire welding, the electrode, electrode reel, welding head, nozzle or semiautomatic welding gun are also electrically “hot”.
 - 3.d. Always be sure the work cable makes a good electrical connection with the metal being welded. The connection should be as close as possible to the area being welded.
 - 3.e. Ground the work or metal to be welded to a good electrical (earth) ground.
 - 3.f. Maintain the electrode holder, work clamp, welding cable and welding machine in good, safe operating condition. Replace damaged insulation.
 - 3.g. Never dip the electrode in water for cooling.
 - 3.h. Never simultaneously touch electrically “hot” parts of electrode holders connected to two welders because voltage between the two can be the total of the open circuit voltage of both welders.
 - 3.i. When working above floor level, use a safety belt to protect yourself from a fall should you get a shock.
 - 3.j. Also see Items 6.c. and 8.



ARC RAYS CAN BURN.



- 4.a. Use a shield with the proper filter and cover plates to protect your eyes from sparks and the rays of the arc when welding or observing open arc welding. Headshield and filter lens should conform to ANSI Z87.1 standards.
- 4.b. Use suitable clothing made from durable flame-resistant material to protect your skin and that of your helpers from the arc rays.
- 4.c. Protect other nearby personnel with suitable, non-flammable screening and/or warn them not to watch the arc nor expose themselves to the arc rays or to hot spatter or metal.



FUMES AND GASES CAN BE DANGEROUS.



- 5.a. Welding may produce fumes and gases hazardous to health. Avoid breathing these fumes and gases. When welding, keep your head out of the fume. Use enough ventilation and/or exhaust at the arc to keep fumes and gases away from the breathing zone. **When welding hardfacing (see instructions on container or SDS) or on lead or cadmium plated steel and other metals or coatings which produce highly toxic fumes, keep exposure as low as possible and within applicable OSHA PEL and ACGIH TLV limits using local exhaust or mechanical ventilation unless exposure assessments indicate otherwise. In confined spaces or in some circumstances, outdoors, a respirator may also be required. Additional precautions are also required when welding on galvanized steel.**
- 5.b. The operation of welding fume control equipment is affected by various factors including proper use and positioning of the equipment, maintenance of the equipment and the specific welding procedure and application involved. Worker exposure level should be checked upon installation and periodically thereafter to be certain it is within applicable OSHA PEL and ACGIH TLV limits.
- 5.c. Do not weld in locations near chlorinated hydrocarbon vapors coming from degreasing, cleaning or spraying operations. The heat and rays of the arc can react with solvent vapors to form phosgene, a highly toxic gas, and other irritating products.
- 5.d. Shielding gases used for arc welding can displace air and cause injury or death. Always use enough ventilation, especially in confined areas, to insure breathing air is safe.
- 5.e. Read and understand the manufacturer’s instructions for this equipment and the consumables to be used, including the Safety Data Sheet (SDS) and follow your employer’s safety practices. SDS forms are available from your welding distributor or from the manufacturer.
- 5.f. Also see item 1.b.



WELDING AND CUTTING SPARKS CAN CAUSE FIRE OR EXPLOSION.

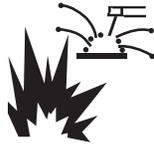

- 6.a. Remove fire hazards from the welding area. If this is not possible, cover them to prevent the welding sparks from starting a fire. Remember that welding sparks and hot materials from welding can easily go through small cracks and openings to adjacent areas. Avoid welding near hydraulic lines. Have a fire extinguisher readily available.
- 6.b. Where compressed gases are to be used at the job site, special precautions should be used to prevent hazardous situations. Refer to "Safety in Welding and Cutting" (ANSI Standard Z49.1) and the operating information for the equipment being used.
- 6.c. When not welding, make certain no part of the electrode circuit is touching the work or ground. Accidental contact can cause overheating and create a fire hazard.
- 6.d. Do not heat, cut or weld tanks, drums or containers until the proper steps have been taken to insure that such procedures will not cause flammable or toxic vapors from substances inside. They can cause an explosion even though they have been "cleaned". For information, purchase "Recommended Safe Practices for the Preparation for Welding and Cutting of Containers and Piping That Have Held Hazardous Substances", AWS F4.1 from the American Welding Society (see address above).
- 6.e. Vent hollow castings or containers before heating, cutting or welding. They may explode.
- 6.f. Sparks and spatter are thrown from the welding arc. Wear oil free protective garments such as leather gloves, heavy shirt, cuffless trousers, high shoes and a cap over your hair. Wear ear plugs when welding out of position or in confined places. Always wear safety glasses with side shields when in a welding area.
- 6.g. Connect the work cable to the work as close to the welding area as practical. Work cables connected to the building framework or other locations away from the welding area increase the possibility of the welding current passing through lifting chains, crane cables or other alternate circuits. This can create fire hazards or overheat lifting chains or cables until they fail.
- 6.h. Also see item 1.c.
- 6.i. Read and follow NFPA 51B "Standard for Fire Prevention During Welding, Cutting and Other Hot Work", available from NFPA, 1 Batterymarch Park, PO box 9101, Quincy, MA 022690-9101.
- 6.j. Do not use a welding power source for pipe thawing.



CYLINDER MAY EXPLODE IF DAMAGED.



- 7.a. Use only compressed gas cylinders containing the correct shielding gas for the process used and properly operating regulators designed for the gas and pressure used. All hoses, fittings, etc. should be suitable for the application and maintained in good condition.
- 7.b. Always keep cylinders in an upright position securely chained to an undercarriage or fixed support.
- 7.c. Cylinders should be located:
 - Away from areas where they may be struck or subjected to physical damage.
 - A safe distance from arc welding or cutting operations and any other source of heat, sparks, or flame.
- 7.d. Never allow the electrode, electrode holder or any other electrically "hot" parts to touch a cylinder.
- 7.e. Keep your head and face away from the cylinder valve outlet when opening the cylinder valve.
- 7.f. Valve protection caps should always be in place and hand tight except when the cylinder is in use or connected for use.
- 7.g. Read and follow the instructions on compressed gas cylinders, associated equipment, and CGA publication P-1, "Precautions for Safe Handling of Compressed Gases in Cylinders," available from the Compressed Gas Association, 14501 George Carter Way Chantilly, VA 20151.



FOR ELECTRICALLY POWERED EQUIPMENT.



- 8.a. Turn off input power using the disconnect switch at the fuse box before working on the equipment.
- 8.b. Install equipment in accordance with the U.S. National Electrical Code, all local codes and the manufacturer's recommendations.
- 8.c. Ground the equipment in accordance with the U.S. National Electrical Code and the manufacturer's recommendations.

Refer to
<http://www.lincolnelectric.com/safety>
for additional safety information.

Electromagnetic Compatibility (EMC)

Conformance

Products displaying the CE mark are in conformity with European Community Council Directive of 15 Dec 2004 on the approximation of the laws of the Member States relating to electromagnetic compatibility, 2004/108/EC. It was manufactured in conformity with a national standard that implements a harmonized standard: EN 60974-10 Electromagnetic Compatibility (EMC) Product Standard for Arc Welding Equipment. It is for use with other Lincoln Electric equipment. It is designed for industrial and professional use.

Introduction

All electrical equipment generates small amounts of electromagnetic emission. Electrical emission may be transmitted through power lines or radiated through space, similar to a radio transmitter. When emissions are received by other equipment, electrical interference may result. Electrical emissions may affect many kinds of electrical equipment; other nearby welding equipment, radio and TV reception, numerical controlled machines, telephone systems, computers, etc. Be aware that interference may result and extra precautions may be required when a welding power source is used in a domestic establishment.

Installation and Use

The user is responsible for installing and using the welding equipment according to the manufacturer's instructions. If electromagnetic disturbances are detected then it shall be the responsibility of the user of the welding equipment to resolve the situation with the technical assistance of the manufacturer. In some cases this remedial action may be as simple as earthing (grounding) the welding circuit, see Note. In other cases it could involve construction of an electromagnetic screen enclosing the power source and the work complete with associated input filters. In all cases electromagnetic disturbances must be reduced to the point where they are no longer troublesome.

Note: The welding circuit may or may not be earthed for safety reasons according to national codes. Changing the earthing arrangements should only be authorized by a person who is competent to access whether the changes will increase the risk of injury, e.g., by allowing parallel welding current return paths which may damage the earth circuits of other equipment.

Assessment of Area

Before installing welding equipment the user shall make an assessment of potential electromagnetic problems in the surrounding area. The following shall be taken into account:

- a) other supply cables, control cables, signaling and telephone cables; above, below and adjacent to the welding equipment;
- b) radio and television transmitters and receivers;
- c) computer and other control equipment;
- d) safety critical equipment, e.g., guarding of industrial equipment;
- e) the health of the people around, e.g., the use of pacemakers and hearing aids;
- f) equipment used for calibration or measurement
- g) the immunity of other equipment in the environment. The user shall ensure that other equipment being used in the environment is compatible. This may require additional protection measures;
- h) the time of day that welding or other activities are to be carried out.

Electromagnetic Compatibility (EMC)

The size of the surrounding area to be considered will depend on the structure of the building and other activities that are taking place. The surrounding area may extend beyond the boundaries of the premises.

Methods of Reducing Emissions

Mains Supply

Welding equipment should be connected to the mains supply according to the manufacturer's recommendations. If interference occurs, it may be necessary to take additional precautions such as filtering of the mains supply. Consideration should be given to shielding the supply cable of permanently installed welding equipment, in metallic conduit or equivalent. Shielding should be electrically continuous throughout its length. The shielding should be connected to the welding power source so that good electrical contact is maintained between the conduit and the welding power source enclosure.

Maintenance of the Welding Equipment

The welding equipment should be routinely maintained according to the manufacturer's recommendations. All access and service doors and covers should be closed and properly fastened when the welding equipment is in operation. The welding equipment should not be modified in any way except for those changes and adjustments covered in the manufacturer's instructions. In particular, the spark gaps of arc striking and stabilizing devices should be adjusted and maintained according to the manufacturer's recommendations.

Welding Cables

The welding cables should be kept as short as possible and should be positioned close together, running at or close to floor level.

Equipotential Bonding

Bonding of all metallic components in the welding installation and adjacent to it should be considered. However, metallic components bonded to the work piece will increase the risk that the operator could receive a shock by touching these metallic components and the electrode at the same time. The operator should be insulated from all such bonded metallic components.

Earthing of the Workpiece

Where the workpiece is not bonded to earth for electrical safety, not connected to earth because of its size and position, e.g., ships hull or building steelwork, a connection bonding the workpiece to earth may reduce emissions in some, but not all instances. Care should be taken to prevent the earthing of the workpiece increasing the risk of injury to users, or damage to other electrical equipment. Where necessary, the connection of the workpiece to earth should be made by a direct connection to the workpiece, but in some countries where direct connection is not permitted, the bonding should be achieved by suitable capacitance, selected according to national regulations.

Screening and Shielding

Selective screening and shielding of other cables and equipment in the surrounding area may alleviate problems of interference. Screening of the entire welding installation may be considered for special applications¹.

¹ Portions of the preceding text are contained in EN 60974-10: "Electromagnetic Compatibility (EMC) product standard for arc welding equipment."

ECO design information

The equipment has been designed in order to be compliant with the Directive 2009/125/EC and the Regulation 2019/1784/EU.

Efficiency and idle power consumption:

Name	Efficiency when max power consumption / Idle power consumption	Equivalent model
Power Wave C300 CE	86% / 185W	No equivalent model

Idle state, follow instructions to test idle mode:

1. Connect an Ethernet cable from the port on the machine to a laptop and start up the machine.
2. Open the Power Wave Manager and configure the connection to the machine that is plugged in through the Ethernet.
3. Check the box for the 'System Hibernation Timer' to allow the machine to enter hibernation mode. Set the Hibernation Timer to 15 minutes (the lowest it can go). Wait 15 minutes and once the fans stop spinning the machine is in Hibernate Mode (Idle State).
4. The machine needs to be turned off and back on to come out of the hibernation mode

Efficiency:

The Efficiency procedure itself requires the use of a grid. Power Wave Manager can be downloaded from powerwavesoftware.com along with the Power Wave Manager instruction. The Power Wave Manager instructions explain how to test a machine using a resistive load. This is described in section 6 under calibration.

The value of efficiency and consumption in idle state have been measured by method and conditions defined in the product standard EN 60974-1

Manufacturer's name, product name, code number, product number, serial number and date of production can be read from rating plate and serial number label.

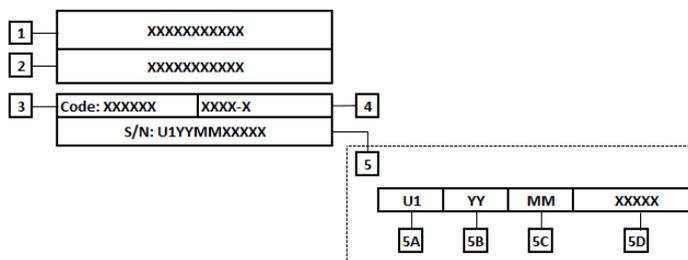

Where:

- | | |
|----------------------------------|---|
| 1- Manufacturer name and address | 5- Serial number |
| 2- Product name | 5A- country of production |
| 3- Code number | 5B- year of production |
| 4- Product number | 5C- month of production |
| | 5D- progressive number different for each machine |

Typical gas usage for **MIG/MAG** equipment:

Material type	Wire diameter [mm]	DC electrode positive		Wire Feeding [m/min]	Shielding Gas	Gas flow [l/min]
		Current [A]	Voltage [V]			
Carbon, low alloy steel	0,9 - 1,1	95 - 200	18 - 22	3,5 – 6,5	Ar 75%, CO ₂ 25%	12
Aluminum	0,8 - 1,6	90 - 240	18 - 26	5,5 – 9,5	Argon	14 - 19
Austenitic stainless steel	0,8 - 1,6	85 - 300	21 - 28	3 - 7	Ar 98%, O ₂ 2% / He 90%, Ar 7,5% CO ₂ 2,5%	14 - 16
Copper alloy	0,9 - 1,6	175 - 385	23 - 26	6 - 11	Argon	12 - 16
Magnesium	1,6 - 2,4	70 - 335	16 - 26	4 - 15	Argon	24 - 28

Tig Process:

In TIG welding process, gas usage depends on cross-sectional area of the nozzle. For commonly used torches:

Helium: 14-24 l/min

Argon: 7-16 l/min

Notice: Excessive flow rates causes turbulence in the gas stream which may aspirate atmospheric contamination into the welding pool.

Notice: A cross wind or draft moving can disrupt the shielding gas coverage, in the interest of saving of protective gas use screen to block air flow .



End of life

At end of life of product, it has to be disposal for recycling in accordance with Directive 2012/19/EU (WEEE), information about the dismantling of product and Critical Raw Material (CRM) present in the product, can be found at: www.lincolnelectriceurope.com

C300 CE

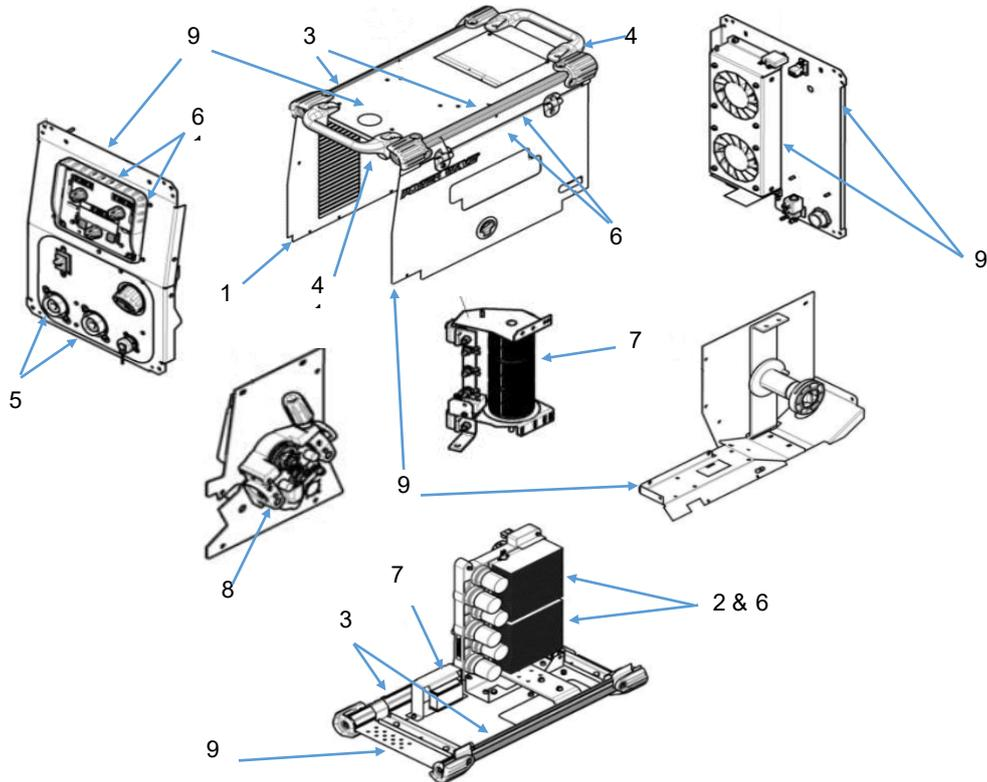

Item	Component	Material for recovery	CRM	Selective treatment
1	Left case side	Steel	-	-
2	Heat sink	Aluminum	Si, 14 g Mg, 23 g	-
3	Rail	Aluminum	Si, 21 g Mg, 14 g	-
4	Handle	Aluminum	Si, 118 g Mg, 1 g	-
5	Output terminal	Brass	-	-
6	PC board	-	-	Required
7	Choke Internal cables	Copper	-	-
8	Feed plate	Aluminum	Si, 39 g Mg, 0.2 g	-
9	Enclosure & internal structure	Aluminum	Si Mg	
10	External cables – not shown	Copper	-	Required

Reference: P-1241-A, code 12756

Installation	Section A
Technical Specifications	A-1, A-2
Safety Precautions	A-3
Location, Lifting	A-3
Stacking	A-3
Tilting.....	A-3
Input and Ground Connections	A-3
Machine Grounding.....	A-3
High Frequency Protection.....	A-3
Input Connection	A-4
Input Fuse and Supply Wire.....	A-4
Input Voltage Selection	A-4
Power Cord Replacement.....	A-4
Recommended Work Cable Sizes	A-5
Remote Sense Lead Specifications, Semi Automatic Welding	A-5
Polarity	A-5
Cable Connections	A-6
Cable Inductance and its Effects on Welding.....	A-6
Shielding Gas Connections	A-7
Loading Spool Wire	A-8
Procedure to Install Drive Rolls and Wire Guides	A-8
Gun Used.....	A-8
Feeding Electrode and Brake Adjustment.....	A-9
Drive Roll Pressure Setting	A-9
TIG Welding	A-10
SMAW Welding.....	A-10
<hr/>	
Operation	Section B
Safety Precautions	B-1
Graphic Symbols.....	B-1
Power-Up Sequence	B-1
Duty Cycle.....	B-1
Product Description	B-2
Recommended Processes and Equipment	B-2
Equipment Limitations	B-3
Common Equipment Packages.....	B-3
Design Features.....	B-3
Case Front Controls	B-4
Case Back Controls.....	B-5
Internal Controls	B-6
Making a Weld with Waveform Technology Power Sources	B-7 thru B-16
Saving and Recalling a Memory	B-17 thru B-19
2 Step - 4 Step Trigger Operation and Graphics	B-20 thru B-25
Cold Feed/Gas Purge Switch.....	B-26
Set-Up Feature Menu	B-27 thru B-35
<hr/>	
Accessories	Section C
General Options / Accessories.....	C-1
TIG Options / Accessories.....	C-1
Wire Feed Options.....	C-1

	Page
Maintenance	Section D
Safety Precautions	D-1
Routine Maintenance	D-1
Periodic Maintenance.....	D-1
Calibration Specification.....	D-1
<hr/>	
Troubleshooting	Section E
Safety Precautions	E-1
How to Use Troubleshooting Guide.....	E-1
Using Status LED and Error Fault Codes	E-2, E-4
Troubleshooting Guide	E-2 thru E-5
Error Fault Codes	E-6, E-7
<hr/>	
Wiring Diagram and Dimension Print	Section F
<hr/>	
Parts Pages	P-635 Series

TECHNICAL SPECIFICATIONS - POWER WAVE® C300 CE

POWER SOURCE-INPUT VOLTAGE AND CURRENT					
Model	Duty Cycle	Input Voltage \pm 10%	Input Amperes	Idle Power	Power Factor @ Rated Output
K2865-1	40% rating	208/230/400*/460/575 3 phase 50/60 Hz (* includes 380V to 415V)	30/28/16/14/11	300 Watts Max. (fan on)	.95
	100% rating		23/21/12/11/9		
RATED OUTPUT					
Process	Duty Cycle	Volts at Rated Amperes		Amperes	
GMAW GMAW-Pulse FCAW	40%	29		300	
	100%	26.5		250	
SMAW	40%	31.2		280	
	100%	29		225	
GTAW-DC	40%	22		300	
	100%	20		250	
RECOMMENDED INPUT WIRE AND FUSE SIZES ¹					
INPUT VOLTAGE / PHASE / FREQUENCY		INPUT AMPERE RATING ON NAMEPLATE	CORD SIZES ³ AWG SIZES (mm ²)	TIME DELAY FUSE OR BREAKER SIZE ² (AMPS)	
208/3/50/60		30	8 (10)	40	
230/3/50/60		28	8 (10)	40	
400/3/50/60		16	12 (4)	25	
460/3/50/60		14	14 (2.5)	20	
575/3/50/60		11	14 (2.5)	15	

¹ Cord and Fuse Sizes based upon the U.S. National Electric Code and maximum output for 40°C (104°) ambient.

² Also called "inverse time" or "thermal/magnetic" circuit breakers; circuit breakers that have a delay in tripping action that decreases as the magnitude of current increases.

³ Type SO cord or similar in 30° C ambient.

WIRE FEED SPEED RANGE-WIRE SIZE				
WFS RANGE	GMAW MILD STEEL	GMAW ALUMINUM	GMAW STAINLESS	FCAW
	WIRE SIZES	WIRE SIZES	WIRE SIZES	WIRE SIZES
50 – 700 ipm (1.3 – 17.8 m/min)	.025 – .045" (0.6 – 1.1mm)	.030 – 3/64" (0.8 – 1.2mm)	.035 – .045" (0.9 – 1.1mm)	.035 – .052" (0.9 – 1.4mm)
WELDING PROCESS				
PROCESS	OUTPUT RANGE (AMPERES)		OCV (U_o)	
GMAW GMAW-Pulse FCAW	40-300		40-70 VDC average, 100V peak	
GTAW-DC	5-300		24 VDC average, 100V peak	
SMAW	5-280		60 VDC average, 100V peak	
WIRE SPEED RANGE				
Wire Speed		50 – 700 IPM (1.27 – 17.8 m/minute)		
PHYSICAL DIMENSIONS				
MODEL	HEIGHT	WIDTH	DEPTH	WEIGHT
K2865-1	18.80in (478mm)	14.00in (356mm)	27.43in (697mm)	100lbs (47.6kg)*
TEMPERATURE RANGES				
OPERATING TEMPERATURE RANGE		STORAGE TEMPERATURE RANGE		
Environmentally Hardened: -4°F to 104°F (-20°C to 40°C)		Environmentally Hardened: -40°F to 185°F (-40°C to 85°C)		

IP23 155°F Insulation Class

* Weight does not include input cord.

Thermal tests have been performed at ambient temperature. The duty cycle (duty factor) at 40°C has been determined by simulation.

POWER WAVE® C300 CE



SAFETY PRECAUTIONS

Read this entire installation section before you start installation.



WARNING



ELECTRIC SHOCK can kill.

- Only qualified personnel should perform this installation.
- Turn the input power OFF at the

disconnect switch or fuse box before working on this equipment. Turn off the input power to any other equipment connected to the welding system at the disconnect switch or fuse box before working on the equipment.

- Do not touch electrically hot parts.
- Always connect the POWER WAVE® C300 CE grounding lug (located inside the reconnect input access door) to a proper safety (Earth) ground.

SELECT SUITABLE LOCATION

The POWER WAVE® C300 CE will operate in harsh environments. Even so, it is important that simple preventative measures are followed in order to assure long life and reliable operation.

- The machine must be located where there is free circulation of clean air such that air movement in the back, out the sides and bottom will not be restricted.
- Dirt and dust that can be drawn into the machine should be kept to a minimum. The use of air filters on the air intake is not recommended because normal air flow may be restricted. Failure to observe these precautions can result in excessive operating temperatures and nuisance shutdown.
- Keep machine dry. Shelter from rain and snow. Do not place on wet ground or in puddles.
- Do not mount the POWER WAVE® C300 CE over combustible surfaces. Where there is a combustible surface directly under stationary or fixed electrical equipment, that surface shall be covered with a steel plate at least .060" (1.6mm) thick, which shall extend not less than 5.90" (150mm) beyond the equipment on all sides.

LIFTING

Both handles should be used when lifting POWER WAVE® C300 CE. When using a crane or overhead device a lifting strap should be connected to both handles. Do not attempt to lift the POWER WAVE® C300 CE with accessories attached to it.

Do not weld with the POWER WAVE® C300 CE while the machine is suspended by the handles.



WARNING



- Lift only with equipment of adequate lifting capacity.
- Be sure machine is stable when lifting.
- Do not operate machine while suspended when lifting.

FALLING

EQUIPMENT can cause injury.

STACKING

The POWER WAVE® C300 CE cannot be stacked.

TILTING

Place the machine directly on a secure, level surface or on a recommended undercarriage. The machine may topple over if this procedure is not followed.

INPUT AND GROUND CONNECTIONS

Only a qualified electrician should connect the POWER WAVE® C300 CE. Installation should be made in accordance with the appropriate National Electrical Code, all local codes and the information in this manual.

MACHINE GROUNDING



The frame of the welder must be grounded. A ground terminal marked with a ground symbol is located next to the input power connection block.

See your local and national electrical codes for proper grounding methods.

HIGH FREQUENCY PROTECTION

The EMC classification of the POWER WAVE® C300 CE is Industrial, Scientific and Medical (ISM) group 2, class A. The POWER WAVE® C300 CE is for industrial use only. (See **Electromagnetic Compatibility EMC Safety Section**).

Locate the POWER WAVE® C300 CE away from radio controlled machinery. The normal operation of the POWER WAVE® C300 CE may adversely affect the operation of RF controlled equipment, which may result in bodily injury or damage to the equipment.

POWER WAVE® C300 CE



INPUT CONNECTION

⚠ WARNING



Only a qualified electrician should connect the input leads to the POWER WAVE® C300 CE. Connections should be made in accordance with all local and national electrical codes and the connection diagram located on the inside of the reconnect access door of the machine. Failure to do so may result in bodily injury or death.

The supply cable provided with the Power Wave C300 CE is rated for 450 VAC (line-to-neutral). Replace the supply cable in accordance with all national and local codes when operating at higher voltages.

A 15 ft. (4.6m) power cord is provided and wired into the machine.

Single Phase Input not supported.

Three Phase Input

Connect green/yellow lead to ground per National Electric Code.

Connect grey, brown and black leads to power.

INPUT FUSE AND SUPPLY WIRE CONSIDERATIONS

Refer to Specification Section for recommended fuse, wire sizes and type of the copper wires. Fuse the input circuit with the recommended super lag fuse or delay type breakers (also called "inverse time" or "thermal/magnetic" circuit breakers). Choose input and grounding wire size according to local or national electrical codes. Using input wire sizes, fuses or circuit breakers smaller than recommended may result in "nuisance" shut-offs from welder inrush currents, even if the machine is not being used at high currents.

INPUT VOLTAGE SELECTION

The POWER WAVE® C300 CE automatically adjusts to work with different input voltages. No reconnect switches settings are required.

⚠ WARNING



The POWER WAVE® C300 CE ON/OFF switch is not intended as a service disconnect for this equipment. Only a qualified electrician should connect the input leads to the POWER WAVE® C300 CE.

Connections should be made in accordance with all local and national electrical codes and the connection diagram located on the inside of the reconnect access door of the machine. Failure to do so may result in bodily injury or death.

POWER CORD REPLACEMENT

⚠ WARNING



Only a qualified electrician should connect the input leads to the POWER WAVE® C300 CE. Connections should be made in accordance with all local and national electrical codes and the connection diagram located on the inside of the reconnect access door of the machine. Failure to do so may result in bodily injury or death.

Connections should be made in accordance with all local and national electrical codes and the connection diagram located on the inside of the reconnect access door of the machine. Failure to do so may result in bodily injury or death.

If the input power cord is damaged or needs to be replaced an input power connection block is located in the access panel under the wire spool.

ALWAYS CONNECT THE POWER WAVE GROUNDING LUG (LOCATED INSIDE THE ACCESS PANEL) TO A PROPER SAFETY (EARTH) GROUND.

FIGURE A.1

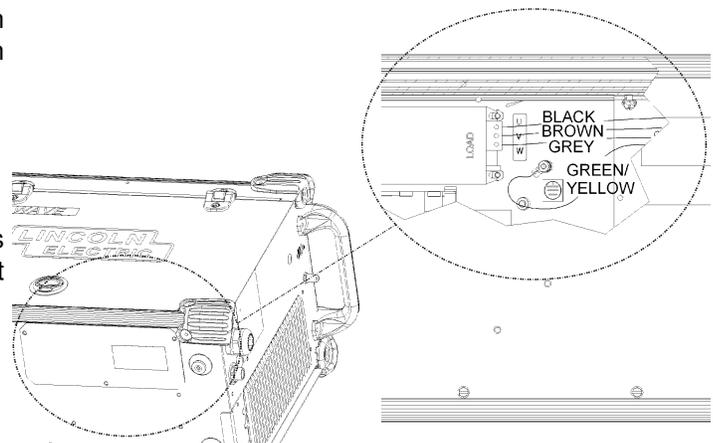

RECOMMENDED WORK CABLE SIZES FOR ARC WELDING

A work cable is provided with the POWER WAVE® C300 CE. This cable is appropriately sized for all of the POWER WAVE® C300 CE's welding procedures. If the work cable needs to be replaced a similar quality of cable should be used as excessive voltage drops caused by undersized welding cables can result in unsatisfactory welding performance. Always use the largest work cables that is practical, and be sure all connections are clean and tight.

Note: Excessive heat in the weld circuit indicates undersized cables and/or bad connections.

REMOTE SENSE LEAD SPECIFICATIONS

Since the POWER WAVE® C300 CE has the ability to be in close proximity to the welding arc, the POWER WAVE® C300 CE does not require the use of remote sense leads.

SEMI-AUTOMATIC WELDING POLARITY

The Fast Mate adapter is permanently wired for Electrode Positive welding for all GMAW and FCAW processes.

The polarity for GTAW and SMAW processes is determined by connecting the electrode lead to either the + or – output stud on the front of the machine

CABLE CONNECTION

There is one circular connection on the front of the machine.

(See Figure A.2---Table A.1)

TABLE A.1

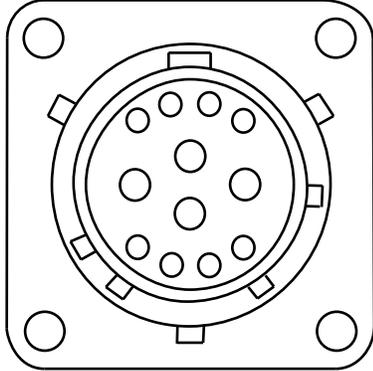
FIGURE A.2	Function	PIN	Wiring
	12 pin connector for Push pull guns; foot pedal; remote controls; Hand -amptrols.	A	CANL
		B	CANH
		C	Remote Pot Common
		D	Remote Pot Wiper
		E	Remote Pot +10VDC
		F	ArcLink Peripheral Sense
		G	Trigger
		H	Trigger
		J	Power Common
		K	Power +
		L	Motor Negative
		M	Motor Positive

CABLE INDUCTANCE AND ITS EFFECTS ON WELDING

Whenever possible always weld in a direction away from the work (ground) connection.

Excessive cable inductance will cause the welding performance to degrade. There are several factors that contribute to the overall inductance of the cabling system including cable size, and loop area. The loop area is defined by the separation distance between the electrode and work cables, and the overall welding loop length. The welding loop length is defined as the total of length of the electrode cable (A) + work cable (B) + work path (C) (see Figure A.3).

To minimize inductance always use the appropriate size cables, and whenever possible, run the electrode and work cables in close proximity to one another to minimize the loop area. Since the most significant factor in cable inductance is the welding loop length, avoid excessive lengths and do not coil excess cable. For long work piece lengths, a sliding ground should be considered to keep the total welding loop length as short as possible.

For additional Safety information regarding the electrode and work cable set-up, See the standard **“SAFETY INFORMATION”** located in the front of this Instruction Manual.

FIGURE A.3

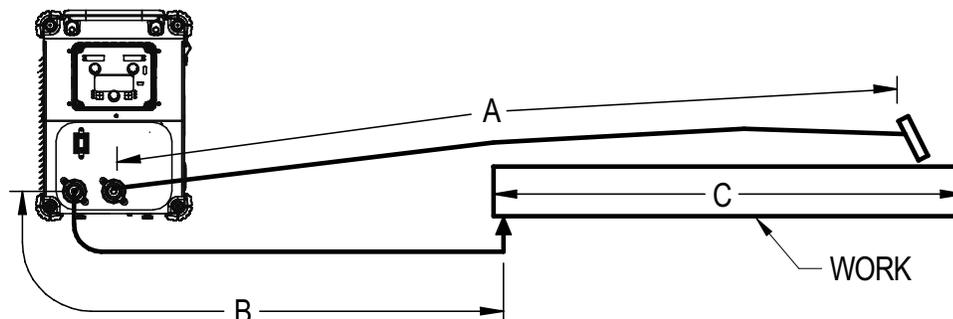

POWER WAVE® C300 CE

LINCOLN
ELECTRIC

SHIELDING GAS CONNECTION

⚠ WARNING

CYLINDER may explode if damaged.

• **Keep cylinder upright and chained to support.**

- **Keep cylinder away from areas where it may be damaged.**
 - **Never lift welder with cylinder attached.**
 - **Never allow welding electrode to touch cylinder.**
 - **Keep cylinder away from welding or other live electrical circuits.**
- BUILD UP OF SHIELDING GAS MAY HARM HEALTH OR KILL.**
- Shut off shielding gas supply when not in use.**
- **See American National Standard Z-49.1, "Safety in Welding and Cutting" Published by the American Welding Society.**



Customer must provide a cylinder of shielding gas, a pressure regulator, a flow control valve, and a hose from the flow valve to the gas inlet fitting of the wire drive unit. Connect a supply hose from the gas cylinder flow valve outlet to the 5/8-18 female inert gas fitting on the back panel of the POWER WAVE® C300 CE.

MAXIMUM INLET PRESSURE IS 100 PSI. (6.9 BAR.)

Install the shielding gas supply as follows:

1. Secure the cylinder to prevent it from falling.
2. Remove the cylinder cap. Inspect the cylinder valves and regulator for damaged threads, dirt, dust, oil or grease. Remove dust and dirt with a clean cloth. **DO NOT ATTACH THE REGULATOR IF OIL, GREASE OR DAMAGE IS PRESENT!** Inform your gas supplier of this condition. Oil or grease in the presence of high pressure oxygen is explosive.
3. Stand to one side away from the outlet and open the cylinder valve for an instant. This blows away any dust or dirt which may have accumulated in the valve outlet.
4. Attach the flow regulator to the cylinder valve and tighten the union nut(s) securely with a wrench. Note: if connecting to 100% CO₂ cylinder, insert regulator adapter between regulator and cylinder valve. If adapter is equipped with a plastic washer, be sure it is seated for connection to the CO₂ cylinder.
5. Attach one end of the inlet hose to the outlet fitting of the flow regulator. Attach the other end to the welding system shielding gas inlet. Tighten the union nuts with a wrench.
6. Before opening the cylinder valve, turn the regulator adjusting knob counterclockwise until the adjusting spring pressure is released.
7. Standing to one side, open the cylinder valve slowly a fraction of a turn. When the cylinder pressure gage stops moving, open the valve fully.
8. The flow regulator is adjustable. Adjust it to the flow rate recommended for the procedure and process being used before making a weld.

LOADING SPOOLS OF WIRE

⚠ WARNING

- Keep hands, hair, clothing and tools away from rotating equipment.



- Do not wear gloves when threading wire or changing wire spool.
- Only qualified personnel should install, use or service this equipment.

Loading 10 to 15 lb. (4.5 – 6.8kg) Spools.

A K468 spindle adapter is required for 8" (203.2mm) spools.

1. Squeeze the release bar on the retaining collar and remove it from the spindle.
2. Place the spindle adapter on the spindle, aligning the spindle brake pin with the hole in the adapter.
3. Place the spool on the spindle and align the adapter brake tab with one of the holes in the back side of the spool. An indicator mark on the end of the spindle shows the orientation of the brake tab. Be certain the wire feeds off of the spool in the proper direction.
4. Re-install the retaining collar. Make sure that the release bar snaps out and that the retaining collar fully engages the groove on the spindle.

Loading 16 to 44 lb. (7.3 – 20kg) Spools

1. Squeeze the release bar on the retaining collar and remove it from the spindle.
2. Place the spool on the spindle, aligning the spindle brake pin with one of the holes in the back side of the spool. An indicator mark on the end of the spindle shows the orientation of the brake holding pin. Be certain the wire feeds off of the spool in the proper direction.
3. Re-install the retaining collar. Make sure that the release bar snaps out and that the retaining collar fully engages the groove on the spindle.

PROCEDURE TO INSTALL DRIVE ROLLS AND WIRE GUIDES

⚠ WARNING



- Turn the input power OFF at the welding power source before installation or changing drive rolls and/or guides.
- Do not touch electrically live parts.
- When inching with the gun trigger, electrode and drive mechanism are "hot" to work and ground and could remain energized several seconds after the gun trigger is released.
- Do not operate with covers, panels or guards removed or open.
- Only qualified personnel should perform maintenance work.

1. Turn power off at the welding power source.
2. Release the idle roll pressure arm.
3. Remove the outer wire guide by turning the knurled thumbscrews counter-clockwise to unscrew them from the feed plate.
4. Rotate the triangular lock and remove the drive rolls. (See Figure A.5)

FIGURE A.5

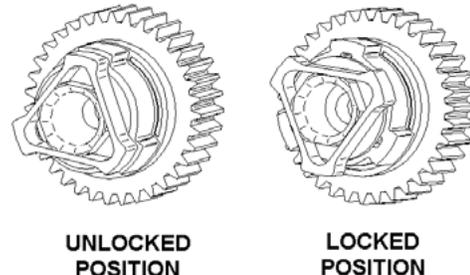

5. Remove the inner wire guide.
6. Insert the new inner wire guide, groove side out, over the two locating pins in the feed plate.
7. Install a drive roll on each hub assembly secure with the triangular lock.
8. Install the outer wire guide by aligning it with the pins and tightening the knurled thumbscrews.
9. Close the idle arm and engage the idle roll pressure arm. Adjust the pressure appropriately.

GUN USED

The Magnum 350 PRO is the recommended gun for the POWER WAVE® C300 CE. Refer to the Magnum Pro's operators manual for installation instructions.

FEEDING ELECTRODE AND BRAKE ADJUSTMENT

DRIVE ROLL PRESSURE SETTING



ELECTRIC SHOCK can kill.

- Turn the input power **OFF** at the welding power source before installation or changing drive rolls and/or guides.
- Do not touch electrically live parts.
- When feeding with the gun trigger, unless “COLD FEED” trigger mode is selected, the electrode and drive mechanism are always “HOT” to work and ground and could remain “HOT” several seconds after the gun trigger is released.
- Do not operate with covers, panels or guards removed or open
- Only qualified personnel should perform maintenance work.

The POWER WAVE® C300 CE's optimum drive roll pressure varies with type of wire, surface condition, lubrication, and hardness. Too much pressure could cause birdnesting, but too little pressure could cause wire feed slippage with load and/or acceleration. The optimum drive roll setting can be determined as follows:

1. Turn the Reel or spool until the free end of the electrode is accessible.
2. While tightly holding the electrode, cut off the bent end and straighten the first 6" (150 mm). Cut off the first 1" (25 mm). (If the electrode is not properly straightened, it may not feed or may jam causing a "birdnest".)
3. Insert the free end through the incoming guide tube.
4. Press the Cold Inch key and push the electrode into the drive roll.
5. Feed the electrode through the gun.
6. Adjust the brake tension with the thumbscrew on the spindle hub, until the reel turns freely but with little or no overrun when wire feeding is stopped. Do not over tighten.

PRESSURE ARM ADJUSTMENT

The pressure arm controls the amount of force the drive rolls exert on the wire. Proper adjustment of pressure arm gives the best welding performance.

Set the pressure arm as follows (See Figure A.6):

Aluminum wires	between 1 and 3
Cored wires	between 3 and 4
Steel, Stainless wires	between 4 and 6

FIGURE A.6

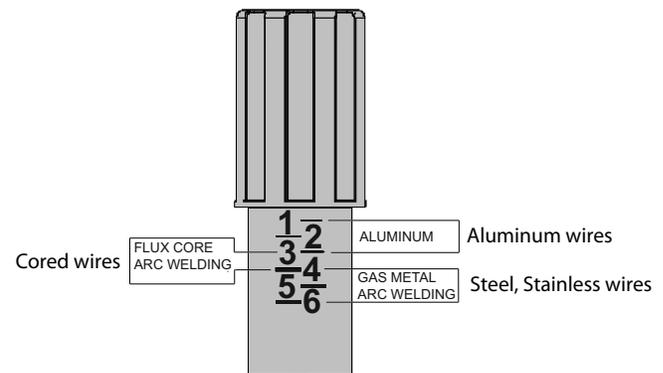

TIG WELDING

(Figure A.7)

When TIG (GTAW) welding with the Power Wave C300CE, a torch with an integral gas valve is required.

SMAW WELDING

Most SMAW welding procedures use Electrode Positive welding. For these applications, connect the stick electrode holder to the positive (+) output stud and connect the work clamp to the negative (-) output stud.

Some SMAW welding procedures use Electrode Negative Polarity. For these applications, connect the stick electrode holder to the negative (-) output stud and connect the work clamp to the positive (+) output stud.

FIGURE A.7

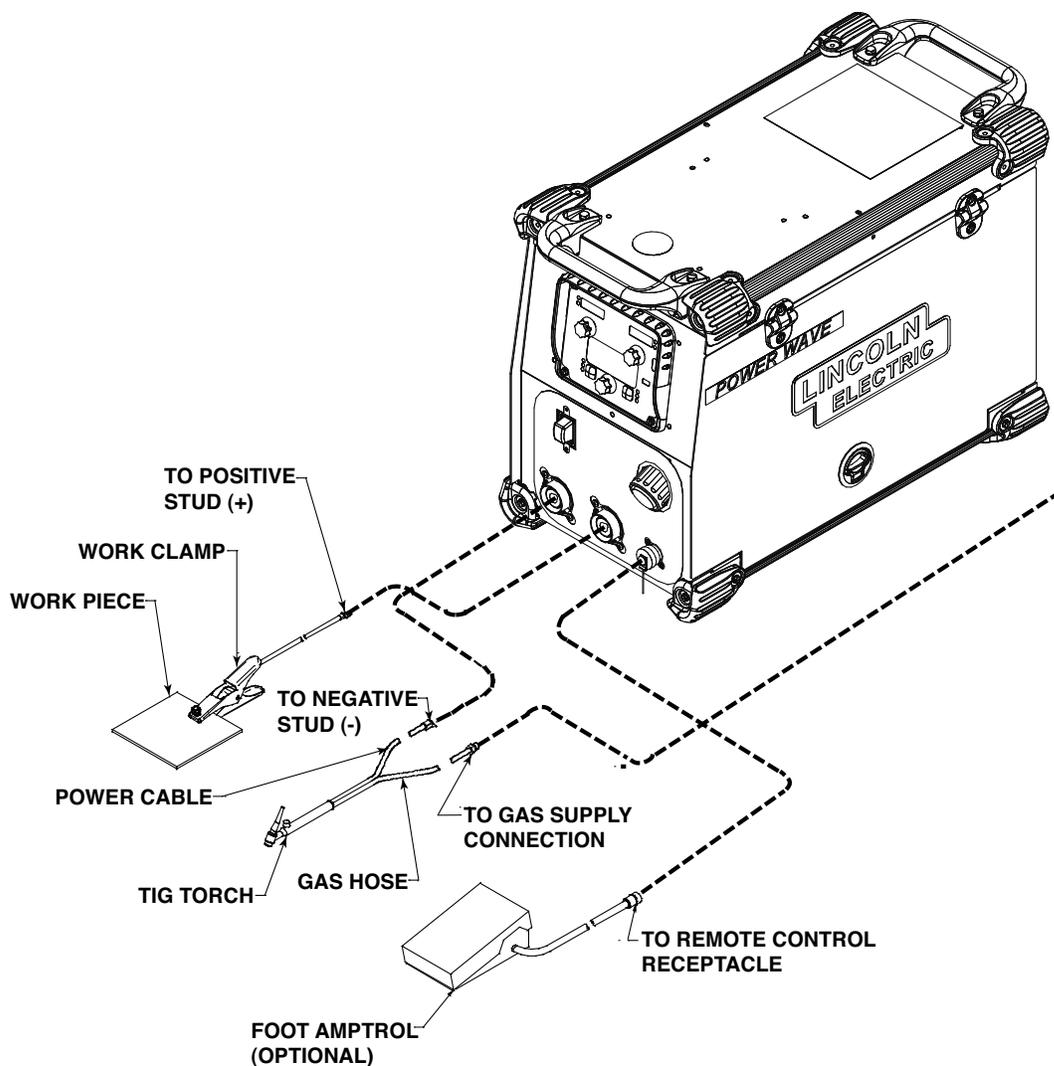

POWER WAVE® C300 CE



SAFETY PRECAUTIONS

READ AND UNDERSTAND ENTIRE SECTION BEFORE OPERATING MACHINE.

⚠ WARNING



- **ELECTRIC SHOCK CAN KILL.** Unless using COLD FEED feature, when feeding with gun trigger, the electrode and drive mechanism are always electrically energized and could remain energized several seconds after the welding ceases.
- Do not touch electrically live part or electrode with skin or wet clothing.
- Insulate yourself from work and ground.
- Always wear dry insulating gloves.
- Do not operate with covers, panels or guards removed or open.



- **FUMES AND GASSES** can be dangerous.
- Keep your head out of fumes.
- Use ventilation or exhaust to remove fumes from breathing zone.



- **WELDING SPARKS** can cause fire or explosion.
- Keep flammable material away.



- **ARC RAYS** can burn.
- Wear eye, ear and body protection.

SEE ADDITIONAL WARNING INFORMATION UNDER ARC WELDING SAFETY PRECAUTIONS AND IN THE FRONT OF THIS OPERATING MANUAL.

GRAPHIC SYMBOLS THAT APPEAR ON THIS MACHINE OR IN THIS MANUAL



WARNING OR CAUTION



DANGEROUS VOLTAGE



POSITIVE OUTPUT



NEGATIVE OUTPUT



HIGH TEMPERATURE



STATUS



PROTECTIVE GROUND



EXPLOSION

POWER-UP SEQUENCE

When the POWER WAVE® C300 CE is powered it can take as long as 30 seconds for the machine to be ready to weld. During this time period the user interface will not be active.

DUTY CYCLE

The POWER WAVE® C300 CE is rated at 250 amps at 26.5 volts with a 100% duty cycle. It is further rated to provide 300 amps at 29 volts with a 40% duty cycle. The duty cycle is based on a ten-minute period. A 40% duty cycle represents 4 minutes of welding and 6 minutes of idling in a ten-minute period.

PRODUCT DESCRIPTION

The POWER WAVE® C300 CE is a high performance multi-process machine with GMAW, FCAW, SMAW, DC TIG, and pulse capability. It will offer a premier welding performance solution for specific areas such as aluminum, stainless, nickel where size and weight are an issue.

The POWER WAVE® C300 CE will provide the following:

- Power - 300A @ 40%, 250A @ 100%.
- Multi Input Voltage with no reconnect - 200-600V, 50-60 Hz input.
- Three Phase Power.
- < 95% Power factor – optimizes available electrical capacity.
- Environmentally Hardened - IP23 rated for operating in difficult environments.
- Versatile Feeding Options – FastMate Mig guns, Spool guns, and Push-pull guns.
- Ethernet connectivity – allows access to the Power Wave utilities software tools.

RECOMMENDED PROCESSES AND EQUIPMENT

RECOMMENDED PROCESSES

The POWER WAVE® C300 CE is a high speed, multi-process power source capable of regulating the current, voltage, or power of the welding arc. With an output range of 5 to 300 amperes, it supports a number of standard processes including synergic GMAW, GMAW-P, FCAW, FCAW-SS, SMAW, GTAW and GTAW-P on various materials especially steel, aluminum and stainless steel.

The following capabilities are supported:

- Push-pull (12-pin) connection - Panther™ and Cougar™.
- Spool gun connection (K2490-1 and K2519-1).
- Remote foot pedal (K870) or hand amptrol (K963-3) via a 12-pin connection.
- Standard MIG gun trigger connection, Integrated in Euro Connector.
- The Gun bushing with Euro Connector installed. Cannot be changed to other gun bushings.
- Watercooler, Integral CoolArc 50.
- Simple process to switch between different welding processes.

PROCESS LIMITATIONS

The software based weld tables of the POWER WAVE® C300 CE limit the process capability within the output range and the safe limits of the machine. In general the processes will be limited to .025-.045 solid steel wire, .035-.045 stainless wire, .035-.052 cored wire, and .035 and 3/64 Aluminum wire. 1/16 Aluminum wire is not supported.

The following items will not be supported on this product, but may be supported by other product in the product portfolio:

- STT
- AC welding processes

WARNING

The POWER WAVE® C300 CE is not recommended for pipe thawing.

EQUIPMENT LIMITATIONS

- Maximum gun length is 25 ft (7.6m) for push-only systems.
- Maximum gun length is 50 ft (15.2) for push-pull systems.
- Maximum spool size is 12 in (305 mm) diameter.
- Maximum spool weight is 44 lb (20 kg).
- The Fast Mate Adapter is integral to the machine and cannot be changed to other gun bushings
- Wire welding processes are limited to positive polarity only.
- Does not operate on single phase power

DESIGN FEATURES

Loaded with Standard Features

- Multiple process DC output range: 5 - 300 Amps.
 - 208 – 575 VAC, 3 phase, 50-60Hz input power.
 - New and Improved Line Voltage Compensation holds the output constant over wide input voltage fluctuations.
 - Utilizes next generation microprocessor control, based on the ArcLink® platform.
 - State of the art power electronics technology, yields superior welding capability.
 - Electronic over current protection.
 - Input over voltage protection.
 - F.A.N. (fan as needed). Cooling fan runs when the output is energized 15 seconds following the strike of the welding arc and will continue to run 5 minutes following the end of the weld.
 - Thermostatically protected for safety and reliability.
 - Recessed connection panel for protection against accidental impact.
 - Ethernet connectivity.
 - Panel mounted Status and Thermal LED indicators facilitate quick and easy troubleshooting.
 - Potted PC boards for enhanced ruggedness/reliability.
 - Enclosure reinforced with heavy duty aluminum extrusions for mechanical toughness.
 - Push-Pull ready for welding aluminum.
 - Remote control/Foot amptrol ready.
 - Waveform Control Technology™ for good weld appearance and low spatter, even when welding nickel alloys.
 - 8 memories for easily selecting procedures.
 - Full sequence control for tailoring the weld from start to end.
 - Patented MAXTRAC™ 2 roll drive system.
 - Patent pending drive rolls improve traction on solid wire by up to 20%.
 - The precision machined, rigid aluminum alloy frame results in maximum drive roll clamping pressure.
 - Patented split wire guides fully support the wire and virtually eliminate birdnesting.
 - No tools required to change the drive rolls and wire guides.
- Patented dual spring pressure arms have sensitivity for feeding soft wires without crushing them, and have plenty of compression force for feeding solid or stiff wires.
 - All gear driven rolls for more feeding force.
 - Brass-to-brass connections between the electrode connection and the gun minimize voltage drop variations, resulting in consistent arc performance all day, every day.
 - Powerful, quiet motor with integrated tachometer for accurate WFS regulation.
 - Multiple language selection for user interface text.

CASE FRONT CONTROLS

FIGURE B.1

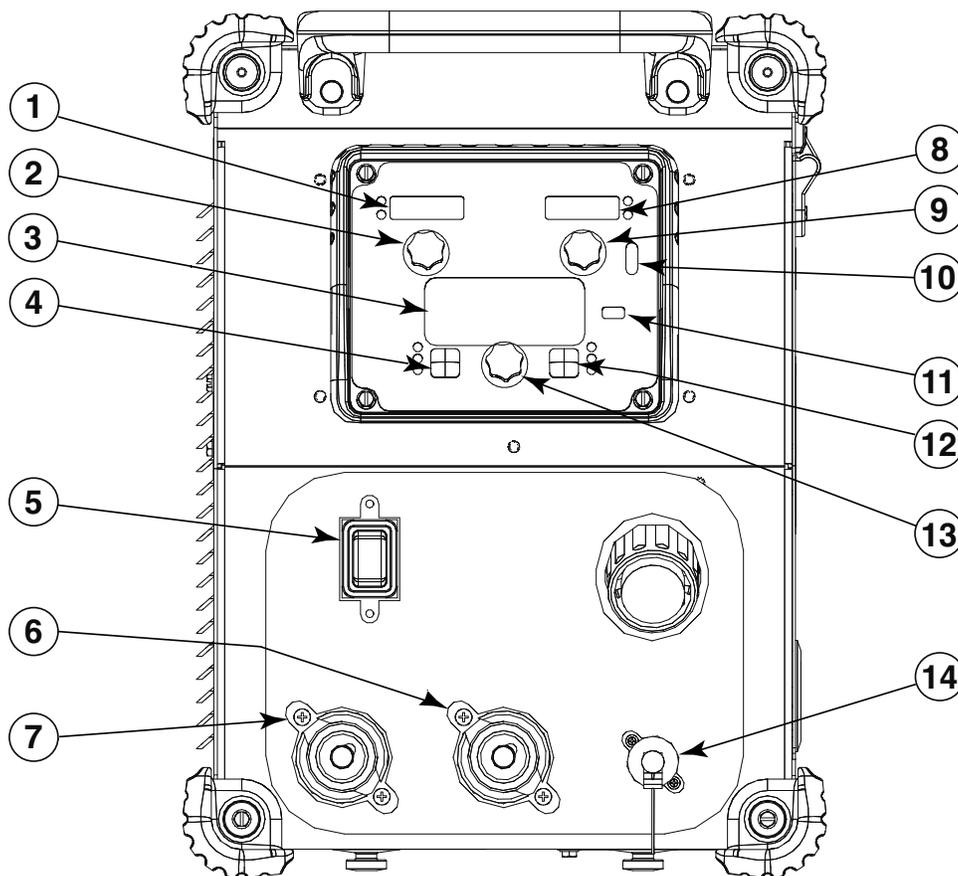

All operator controls and adjustments are located on the case front of the Power Wave. (See Figure B.1)

1. **LEFT DISPLAY**- Shows wire feed speed or amperage,
2. **LEFT KNOB**- Adjusts value in left display.
3. **MAIN DISPLAY**- Shows detailed welding and diagnostic information.
4. **LEFT BUTTON**- Changes the Main display to show the Weld Mode or UltimArc™ Control or Memories.
5. **ON/OFF SWITCH**- Controls power to the Power Wave C300CE.
6. **+ OUTPUT STUD**- Connection for electrode positive.
7. **- OUTPUT STUD**- Connection for electrode negative.
8. **RIGHT DISPLAY**- Shows voltage or trim.
9. **RIGHT KNOB**- Adjusts value in right display.
10. **THERMAL LIGHT**- Indicates when machine has thermal fault.
11. **SET-UP**- Lights when machine is in set-up mode,
12. **RIGHT BUTTON**- Changes the Main display to arc start, arc end and trigger options.
13. **MAIN KNOB**- Changes the values on the Main display.
14. **12 PIN CONNECTOR**- Connection for push pull guns, remotes.

POWER WAVE® C300 CE



CASE BACK CONTROLS

FIGURE B.2

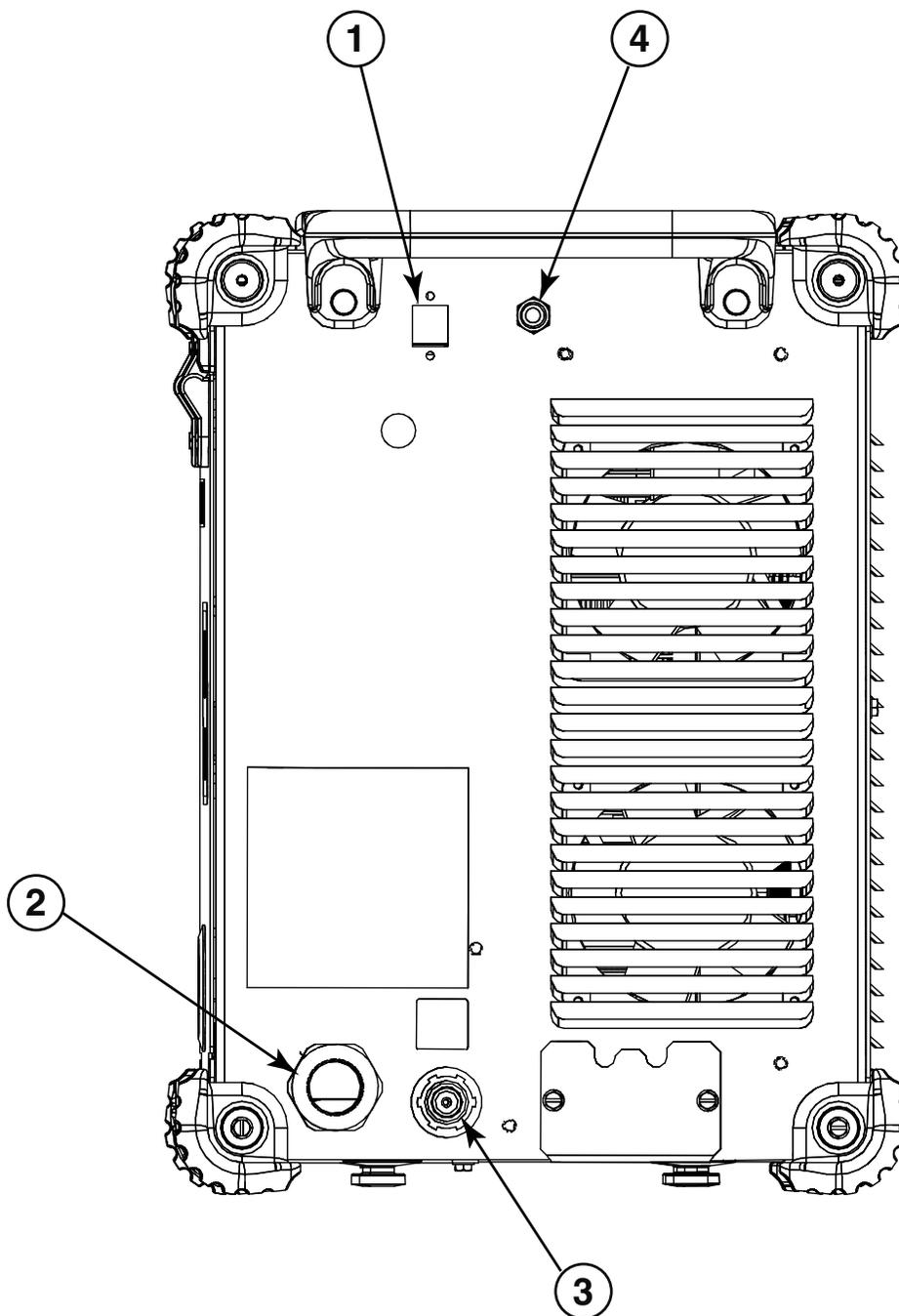

- 1. ETHERNET CONNECTOR
- 2. POWER CORD
- 3. GAS CONNECTION
- 4. CIRCUIT BREAKER

POWER WAVE® C300 CE



OPERATION

INTERNAL CONTROLS

FIGURE B.3

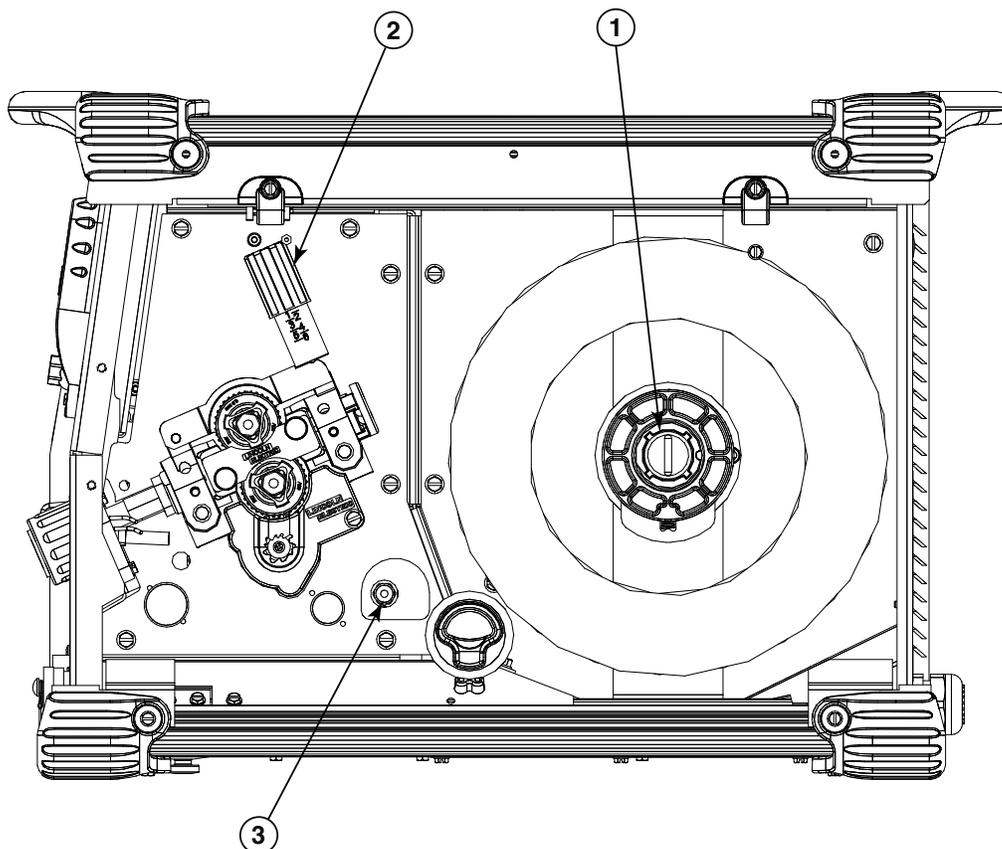

1. SPINDLE BRAKE

2. WIRE DRIVE PRESSURE ARM

3. COLD INCH / GAS PURGE SWITCH

POWER WAVE® C300 CE

LINCOLN
ELECTRIC

MAKING A WELD WITH WAVEFORM TECHNOLOGY POWER SOURCES

WARNING

MAKING A WELD

The serviceability of a product or structure utilizing the welding programs is and must be the sole responsibility of the builder/user. Many variables beyond the control of The Lincoln Electric Company affect the results obtained in applying these programs. These variables include, but are not limited to, welding procedure, plate chemistry and temperature, weldment design, fabrication methods and service requirements. The available range of a welding program may not be suitable for all applications, and the build/user is and must be solely responsible for welding program selection.

Choose the electrode material, electrode size, shielding gas, and process (GMAW, GMAW-P etc.) appropriate for the material to be welded.

Select the weld mode that best matches the desired welding process. The standard weld set shipped with the Power Wave C300 encompasses a wide range of common processes that will meet most needs. If a special weld mode is desired, contact the local Lincoln Electric sales representative.

All adjustments are made through the user interface. Because of the different configuration options your system may not have all of the following adjustments. Regardless of availability, all controls are described in the following section (See Figure B.4 Panel Controls Used)

DEFINITION OF WELDING MODES

NON-SYNERGIC WELDING MODES

- A Non-synergic welding mode requires all welding process variables to be set by the operator.

SYNERGIC WELDING MODES

- A Synergic welding mode offers the simplicity of single knob control. The machine will select the correct voltage and amperage based on the wire feed speed (WFS) set by the operator.

BASIC WELDING CONTROLS

WELD MODE

Selecting a weld mode determines the output characteristics of the Power Wave power source. Weld modes are developed with a specific electrode material, electrode size, and shielding gas. For a more complete description of the weld modes programmed into the Power Wave at the factory, refer to the Weld Set Reference Guide supplied with the machine or available at www.powerwavesoftware.com.

WIRE FEED SPEED (WFS)

In synergic welding modes (synergic CV, GMAW-P), WFS is the dominant control parameter. The user adjusts WFS according to factors such as wire size, penetration requirements, heat input, etc. The Power Wave then uses the WFS setting to adjust the voltage and current according to settings contained in the Power Wave.

In non-synergic modes, the WFS control behaves like a conventional power source where WFS and voltage are independent adjustments. Therefore, to maintain proper arc characteristics, the operator must adjust the voltage to compensate for any changes made to the WFS.

AMPS

In constant current modes, this control adjusts the welding current.

VOLTS

In constant voltage modes, this control adjusts the welding voltage.

TRIM

In pulse synergic welding modes, the Trim setting adjusts the arc length. Trim is adjustable from 0.50 to 1.50. 1.00 is the nominal setting and is a good starting point for most conditions.

ULTIMARC™ CONTROL

UltimArc™ Control allows the operator to vary the arc characteristics from “soft” to “crisp”. UltimArc™Control is adjustable from -10.0 to +10.0 with a nominal setting of 0.0.

CASE FRONT CONTROLS USED

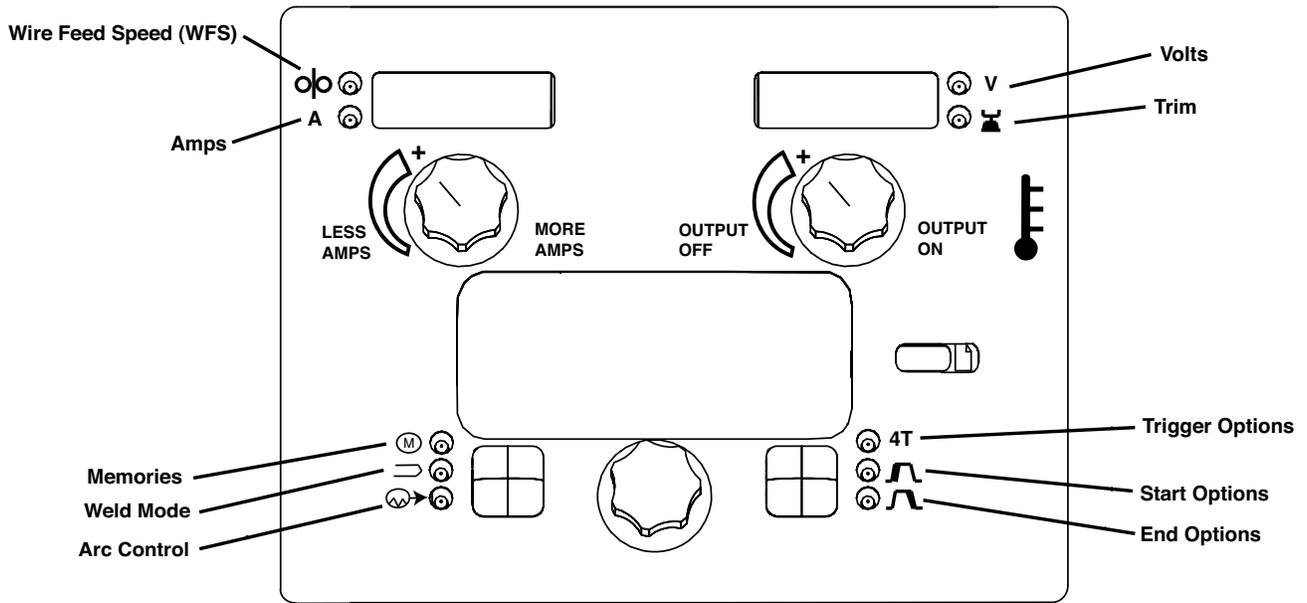

SMAW (STICK) WELDING

SMAW is most often used for outdoor construction, pipe welding and general repairs. The POWER WAVE® C300 CE controls Amperage, Output Control and Arc Force during SMAW welding.

During SMAW welding the wire drive remains idle.

BASIC OPERATION

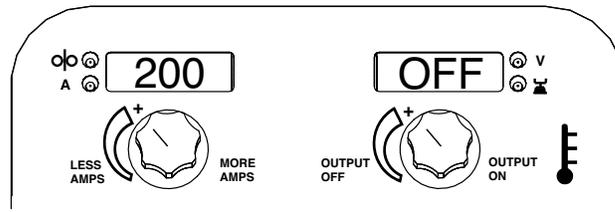

CONTROL OPTIONS

CC STICK MODES	
PROCESS	MODE
Stick Soft(7018)	1
Stick Crisp(6010)	2
Stick Pipe	3

START OPTIONS	
EFFECT / RANGE	DESCRIPTION
START TIME: 0 TO 10 Seconds	If no remote control is installed, this control sets the time for the weld output to ramp up or down from a preset Start current to the preset Weld current. Use the WFS/AMP knob to adjust Start current while the Start Options LED is lit.

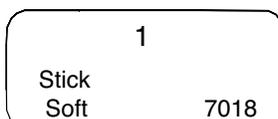

UltimArc™ Control	
EFFECT / RANGE	DESCRIPTION
ARC FORCE (Soft)-10.0 to (Crisp)+10.0	Arc Force adjusts the short circuit current for a soft arc, or for a forceful, driving arc. Lower values will provide less short circuit and softer arc. Higher settings will provide a higher short circuit, a more forceful arc and possibly more spatter.

END OPTIONS
No arc ending options are active for SMAW (Stick) Welding.

NON-SYNERGIC GMAW AND FCAW WELDING

In non-synergic modes, the WFS control is similar to a conventional CV power source where WFS and voltage are independent adjustments. Therefore to maintain the arc characteristics, the operator must adjust the voltage to compensate for any changes made to the WFS.

UltimArc™Control, adjusts the apparent inductance of the wave shape. The UltimArc™Control adjustment is similar to the “pinch” function in that it is inversely proportional to inductance. Therefore, increasing UltimArc™Control greater than 0.0 results in a crisper arc (more spatter) while decreasing the UltimArc™Control to less than 0.0 provides a softer arc (less spatter).

BASIC OPERATION

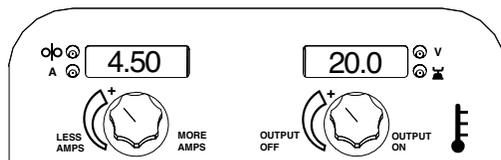

CONTROL OPTIONS

WELD MODE	
PROCESS	WELD MODE
GMAW, STANDARD CV	5
GMAW, POWER MODE	40
FCAW, (SS) STANDARD CV	6
FCAW, (GS) STANDARD CV	7

START OPTIONS	
EFFECT	DESCRIPTION
Preflow Time 0 To 10 Seconds	Adjusts the time that shielding gas flows after the trigger is pulled and prior to feeding wire.
Run-In WFS: Off, .076 To 3.81 in/mjn	Run-In sets the wire feed speed from the time the trigger is pulled until an arc is established.
Start Procedure	The Start Procedure controls the WFS and Volts for a specified time at the beginning of the weld. During the start time, the machine will ramp up or down from the Start Procedure to the preset Welding Procedure.

UltimArc™ Control	
EFFECT / RANGE	DESCRIPTION
PINCH (Soft)-10.0 to (Crisp)+10.0	Pinch controls the arc characteristics when short-arc welding.

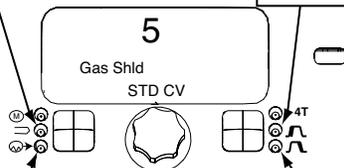

END OPTIONS	
EFFECT	DESCRIPTION
Spot Timer: 0 To 120.0 Seconds	Adjusts the time welding will continue even if the trigger is still pulled. The option has no effect in 4 Step trigger mode.
Crater Procedure	Crater Procedure controls the WFS and Volts for a specified time at the end of the weld after the trigger is released. During the Crater time, the machine will ramp up or down from the Weld Procedure to the Crater Procedure.
Burnback: 0 To 0.25 Seconds	The burnback time is the amount of time that the weld output continues after the wire stops feeding. It prevents the wire from sticking in the puddle and prepares the end of the wire for the next arc start.
Postflow Time 0 To 10.0 Seconds	Adjusts the time that shielding gas flows after the welding output turns off.

GMAW (MIG) SYNERGIC WELDING

In synergic welding modes, WFS is the dominant control parameter. For each wire feed speed, a corresponding voltage is programmed into the machine at the factory. The user adjusts WFS according to factors such as wire size, material thickness, penetration requirements, etc. The Power Wave then uses the WFS setting to select the appropriate voltage. The voltage selected will be a nominal voltage. The user can adjust the voltage higher or lower to compensate for material condition or individual preference.

UltimArc™Control, adjusts the apparent inductance of the wave shape. The UltimArc™Control adjustment is similar to the “pinch” function in that it is inversely proportional to inductance. Therefore, increasing UltimArc™Control greater than 0.0 results in a crisper arc (more spatter) while decreasing the UltimArc™Control to less than 0.0 provides a softer arc (less spatter).

Synergic CV programs feature an ideal voltage best suited for most procedures. Use this voltage as a starting point and adjust if needed for personal preferences.

When the voltage knob is rotated, the display will show an upper or lower bar indicating if the voltage is above or below the ideal voltage.

• Preset voltage above ideal voltage. (upper bar displayed)



• Preset voltage at ideal voltage. (no bar displayed)



• Preset voltage below ideal voltage. (lower bar displayed)



BASIC OPERATION

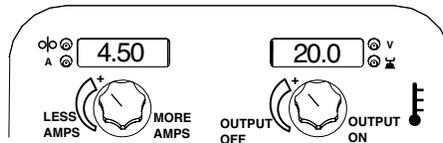

CONTROL OPTIONS

WELD MODE					
ELECTRODE AND GAS		WIRE SIZE			
		.08	.09	1.0	1.2
Steel	CO ₂	93	14	10	20
Steel	Ar(Mix)	94	15	11	21
Stainless	Ar(Mix)	61	29	31	41
Stainless	Ar/He/CO ₂	63	---	---	---
Aluminum 4043	Ar	---	---	---	71
Aluminum 5356	Ar	---	---	151	75

START OPTIONS	
EFFECT	DESCRIPTION
Preflow Time: 0 To 10 Seconds	Adjusts the time that shielding gas flows after the trigger is pulled and prior to feeding.
Run-in WFS: Off, 0.76 to 3.81 m/min.	Run-In sets the wire feed speed from the time the trigger is pulled until an arc is established.
Start Procedure	The Start Procedure controls the WFS, Volts at a specified time at the beginning of the weld. During the start time, the machine will ramp up or down from the Start Procedure to the preset Welding Procedure.

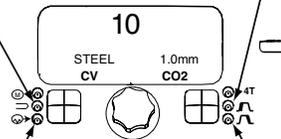

UltimArc™ Control	
EFFECT / RANGE	DESCRIPTION
PINCH EFFECT (-10.0 to +10.0)	Pinch controls the arc characteristics when short-arc welding.

END OPTIONS	
EFFECT	DESCRIPTION
Spot Timer 0 to 120.0 Seconds	Adjust the time welding will continue even if the trigger is still pulled. This option has no effect in 4-Step Trigger Mode.
Crater Procedure	Crater Procedure controls the WFS and Volts for a specified time at the end of the weld after the trigger is released. During the Crater time, the machine will ramp up or down from the Weld Procedure to the Crater Procedure.
Burnback: 0 to 0.25 Seconds	The burnback time is the amount of time that the weld output continues after the wire stops feeding. It prevents the wire from sticking in the puddle and prepares the end of the wire for the next arc start.
Postflow Time 0 to 10 Seconds	Adjusts the time that shielding gas flows after the welding output turns off.

POWER WAVE® C300 CE



STEEL AND STAINLESS SYNERGIC GMAW-P (PULSED MIG) WELDING

When pulse welding, the power source primarily regulates the arc current, not the arc voltage. During a pulsing cycle, arc current is regulated from a low background level to a high peak level and then back down to the low background level. The average arc voltage increases and decreases as the average arc current is increased or decreased. The peak current, back ground current, rise time, fall time and pulse frequency all affect the average voltage. Since the average voltage for a given wire feed speed can only be determined when all the pulsing waveform parameters are known, a unitless value called "trim" is used for adjusting the arc length.

Trim adjusts the arc length and ranges from 0.50 to 1.50 with a nominal value of 1.00. Increasing the trim value increases the arc length. Decreasing the trim value decreases the arc length.

Pulse welding modes are synergic; using wire feed speed as the main control parameter. As the wire feed speed is adjusted, the power source adjusts the waveform parameters to maintain good welding characteristics. Trim is used as a secondary control to change the arc length for material conditions or individual preference. (See Figure B.5)

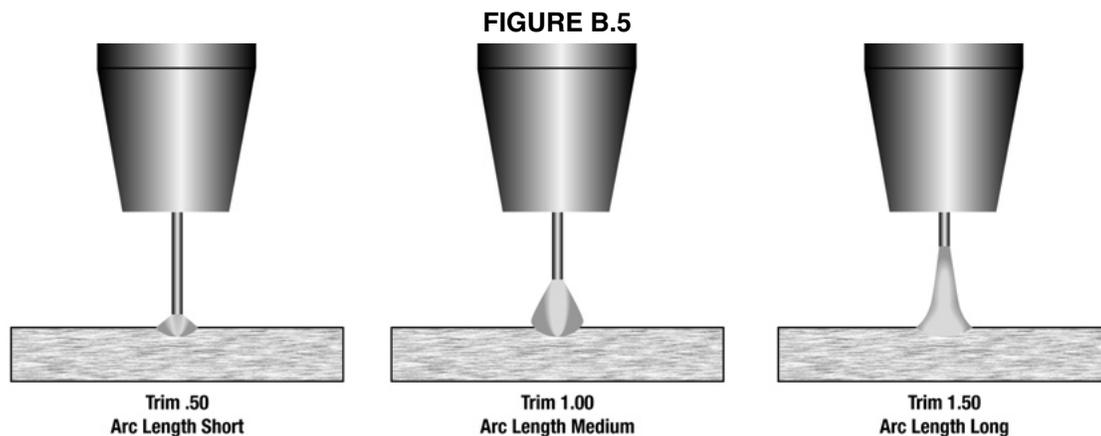

ULTIMARC™ CONTROL

(See Figure B.6)

UltimArc™Control adjusts the focus or shape of the arc. UltimArc™Control is adjustable from -10.0 to +10.0 with a nominal setting of 0.0. Increasing the arc control increases the pulse frequency and background current while decreasing the peak current.

This results in a tight, stiff arc used for high speed sheet metal welding. Decreasing the arc control decreases the pulse frequency and background current while increasing the peak current. This results in a soft arc good for out of position welding.

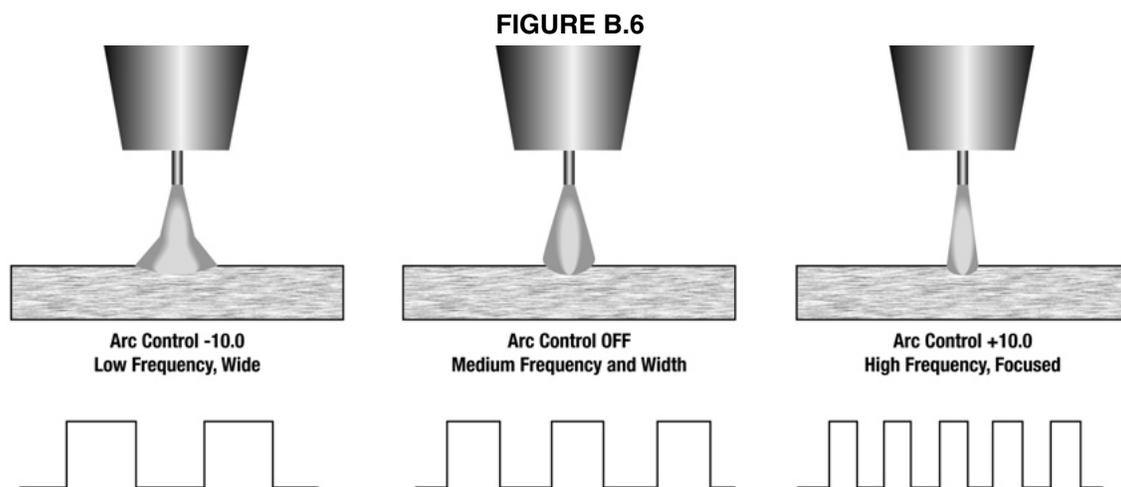

The Power Wave utilizes adaptive control to compensate for changes in the electrical stick-out (distance from the contact tip to the work piece) while welding. The Power Wave waveforms are optimized for a 5/8" to 3/4" stick out depending on the wire type and wire feed speed.

The adaptive behavior supports a range of stick outs from approximately 1/2" to 1-1/4". At low or high wire feed speeds, the adaptive range may be less due to physical limitations of the welding process.

POWER WAVE® C300 CE



STEEL AND STAINLESS GMAW-P (PULSED MIG) WELDING

BASIC OPERATION

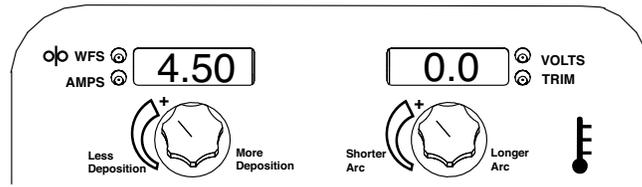

CONTROL OPTIONS

WELD MODE		WIRE SIZE			
ELECTRODE AND GAS		0.8	0.9	1.0	1.2
Steel(Crisp)	Ar(Mix)	95	16	12	22
Steel(Rapid Arc)	Ar(Mix)	---	17	13	18
Steel(Vert Up)	Ar(Mix)	---	---	---	23
Stainless	Ar/CO ₂	66	---	---	---
Stainless	Ar/CO ₂	62	30	32	42
Stainless	Ar/He/CO ₂	64	---	---	---
Stainless(Vert Up)	Ar(Mix)	---	---	---	48

START OPTIONS	
EFFECT	DESCRIPTION
Preflow Time 0 to 10 Seconds	Adjusts the time that shielding gas flows after the trigger is pulled and prior to feeding wire.
RUN-IN WFS: OFF, 0.76 to 3.81m/mm	Run-in sets the wire feed speed from the time the trigger is pulled until an arc is established.
Start Procedure	The Start Procedure controls the WFS, Trim at a specified time at the beginning of the weld. During the start time, the machine will ramp up or down from the Start Procedure to the preset Welding Procedure.

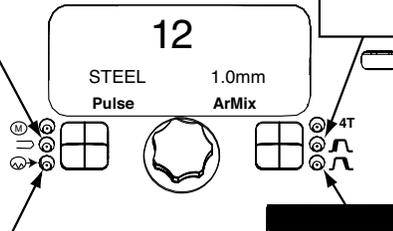

UltimArc™ Control	
EFFECT / RANGE	DESCRIPTION
ARC FOCUS -10.0 (SOFT to 10.0 (STIFF)	Arc Focus adjusts the arc from a wide, soft arc good for out of position work to a narrow, stiff arc preferred for faster travel speeds. The pulse frequency is lower with a soft arc and higher with a stiff arc.

END OPTIONS	
EFFECT	FUNCTION
Spot Timer 0 to 120.0 Seconds	Adjust the time welding will continue even if the trigger is still pulled. This option has no effect in 4-Step Trigger Mode.
Crater Procedure	Crater Procedure controls the WFS and Volts for a specified time at the end of the weld after the trigger is released. During the Crater time, the machine will ramp up or down from the Weld Procedure to the Crater Procedure.
Burnback: 0 to 0.25 Seconds	The burnback time is the amount of time that the weld output continues after the wire stops feeding. It prevents the wire from sticking in the puddle and prepares the end of the wire for the next arc start.
Postflow Time 0 to 10 Seconds	Adjusts the time that shielding gas flows after the welding output turns off.

ALUMINUM SYNERGIC GMAW-P (PULSED MIG) AND GMAW-PP (PULSE ON PULSE) WELDING

The POWER WAVE® C300 CE can produce top quality aluminum welds with excellent appearance, little spatter and good bead shape. Push-pull guns are available for consistent feeding when welding a long distance away from the wire feeder.

PULSE-ON-PULSE WELDING

The Power Wave system offers both traditional pulse and Pulse-on-Pulse™. Pulse-on-Pulse (GMAW-PP) is an exclusive waveform for aluminum welding. Use it to make welds with a "stacked dime" appearance, similar to GTAW welds. (See Figure B.7)

FIGURE B.7

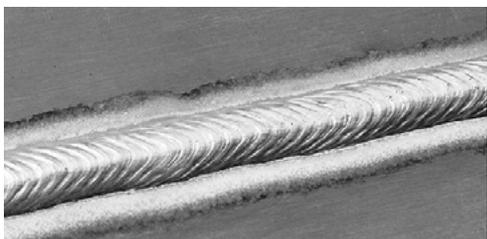

The pulsing frequency is adjustable. Changing the frequency modulation (or arc control) of the waveform changes the ripple spacing. Faster travel speeds may be achieved by using higher values of frequency modulation. (See Figure B.8 and B.9p)

FIGURE B.8

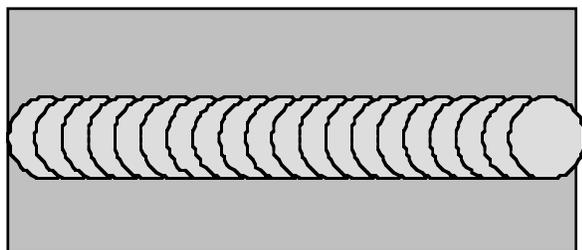

Frequency Modulation = -10

Wide weld and ripple spacing, slow travel speed.

FIGURE B.9

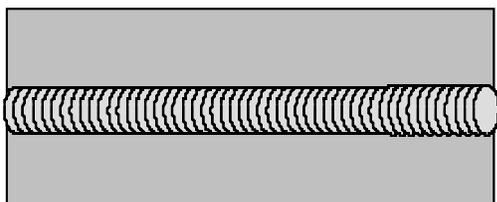

Frequency Modulation = 10

Narrow weld and ripple spacing, fast travel speed.

ALUMINUM GMAW-P AND GMAW-PP

ALUMINUM PULSE WELDING

Synergic GMAW-P (Pulsed MIG) welding is ideal for low spatter, out of position and reduced heat input applications. During pulse welding, the welding current continuously switches from a low level to a high level and then back again. Each pulse sends a small droplet of molten metal from the wire to the weld puddle.

Pulse welding controls the arc length with 'Trim' instead of voltage. When trim (arc length) is adjusted, the Power Wave automatically recalculates the voltage, current and time of each part of the pulse waveform for the best result. Trim adjusts the arc length and ranges from 0.50 to 1.50, with a nominal value of 1.00 for a 3/4" (19mm) electrode stick-out. Trim values greater than 1.00 increase the arc length, while values less than 1.00 decrease the arc length.

(See Figure B.10)

FIGURE B.10

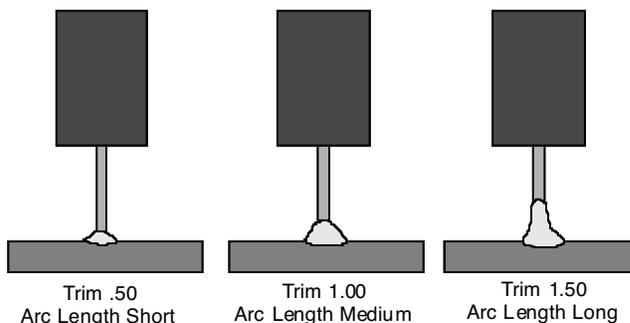

ALUMINUM GMAW-P (PULSED MIG) AND GMAW-PP (PULSE ON PULSE) WELDING

BASIC OPERATION

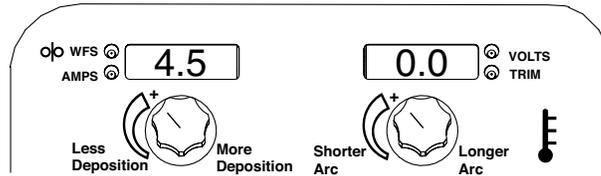

CONTROL OPTIONS

WELD MODES			
ELECTRODE AND GAS		WIRE SIZE	
ALUMINUM 4043 Pulse Ar		---	72
ALUMINUM 4043 Pulse -on-Pulse Ar		---	99
ALUMINUM 5356 Ar		76	152
ALUMINUM 5356 Pulse -on-Pulse Ar		101	102

START OPTIONS	
EFFECT	DESCRIPTION
Preflow Time 0 to 10 Seconds	Adjusts the time that shielding gas flows after the trigger is pulled and prior to feeding wire.
RUN-IN WFS: OFF, 0.76 to 3.81m/mm	Run-in sets the wire feed speed from the time the trigger is pulled until an arc is established.
Start Procedure	The Start Procedure controls the WFS. Trim at a specified time at the beginning of the weld. During the start time, the machine will ramp up or down from the Start Procedure to the preset Welding Procedure.

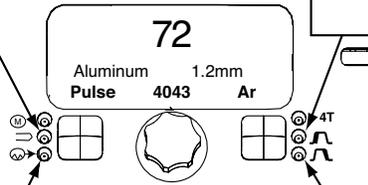

UltimArc™ Control	
EFFECT / RANGE	DESCRIPTION
PULSE FREQUENCY: (Low)-10.0 to (High)+10.0	For Pulse modes, Arc Control changes the pulsing frequency. When the frequency changes, the Power Wave system automatically adjusts the background current to maintain a similar heat input into the weld. Low frequencies give more control over the puddle and high frequencies minimize spatter.
PULSE-ON-PULSE FREQ.MODULATION (Low)-10.0 to (High)+10.0	For Pulse -On-Pulse modes, Arc controls changes the frequency modulation. The frequency modulation controls the spacing of the ripples in the weld. Use low values for slow travel speeds and wide welds, and high values for fast travel speeds and narrower welds.

END OPTIONS	
EFFECT	FUNCTION
Spot Timer 0 to 120.0 Seconds	Adjust the time welding will continue even if the trigger is still pulled. This option has no effect in 4-Step Trigger Mode.
Crater Procedure	Crater Procedure controls the WFS and Volts for a specified time at the end of the weld after the trigger is released. During the Crater time, the machine will ramp up or down from the Weld Procedure to the Crater Procedure.
Burnback: 0 to 0.25 Seconds	The burnback time is the amount of time that the weld output continues after the wire stops feeding. It prevents the wire from sticking in the puddle and prepares the end of the wire for the next arc start.
Postflow Time 0 to 10 Seconds	Adjusts the time that shielding gas flows after the welding output turns off.

GTAW (TIG) WELDING

The POWER WAVE® C300 CE is excellent for (Touch Start TIG) welding.

BASIC OPERATION

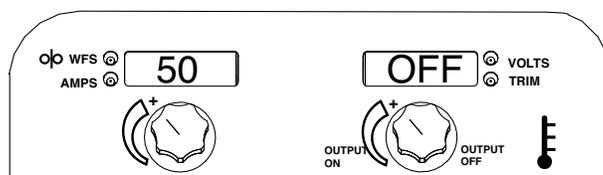

CONTROL OPTIONS

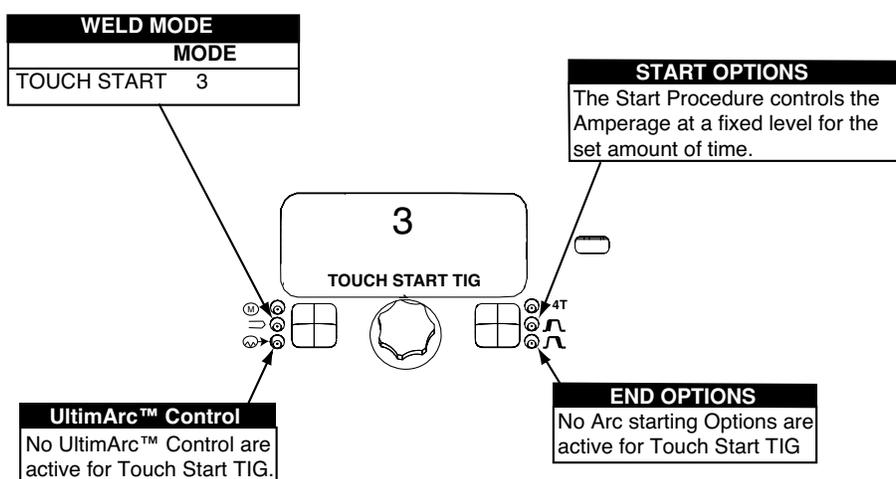

WELD MODE SEARCHING

The Weld Mode Search feature allows the selection of a welding mode based on certain criteria (wire size, process type, etc.).

SEARCHING FOR A WELD MODE

To search for a mode, turn the control knob until “Weld Mode Search” is displayed. This will appear in between the highest and the lowest weld mode numbers.

Once “Weld Mode Search” is displayed, pressing the right pushbutton labeled “Begin” will start the search process.

During the search process, pressing the right pushbutton typically acts as a “next” button and the left pushbutton typically acts as a “back” button.

Rotate the control knob then press the right pushbutton to select relevant welding details such as welding process, wire type, wire size, etc.

When the final selection is made, the C300™ will automatically change to the weld mode found by the Weld Mode Search process.

Earlier products may not have this feature. To activate this feature, a software update may be needed from www.powerwavesoftware.com

SAVING A MEMORY:

To save the current machine settings to the selected memory, **press and hold the center knob for (2 seconds)**. After two seconds, the alphanumeric displays will show **“Memory # Save Memory”** at which time the center knob should be released. After saving to a memory, a message will briefly appear indicating that the selected memory has been saved.

1. Press the Left Push Button until Memory 'M' LED is illuminated.

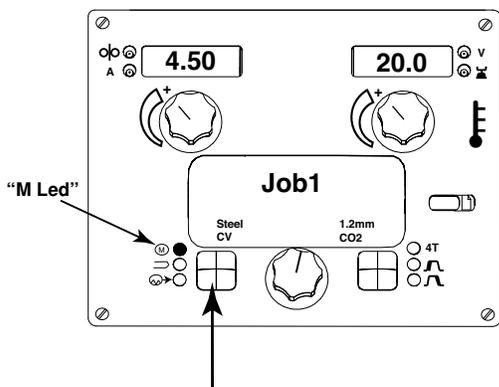

2. Rotate center knob to cycle to desired memory location.

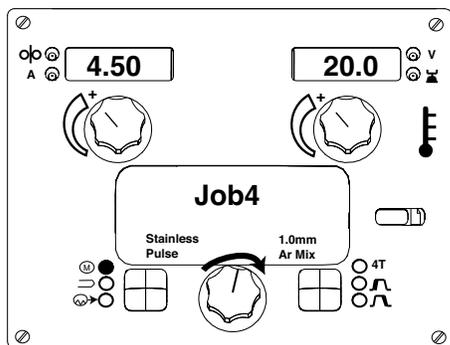

location.

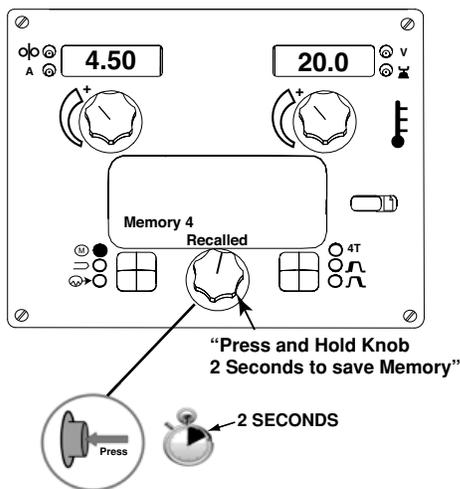

RECALLING A MEMORY

To recall the selected memory, **press and hold center knob for (1 second)**. After recalling a memory, a message will briefly appear indicating that the selected memory has been recalled. The **Memory LED** will remain lit so that the user can quickly recall a different memory if needed.

1. Press the Left Push Button until Memory 'M' LED is illuminated.

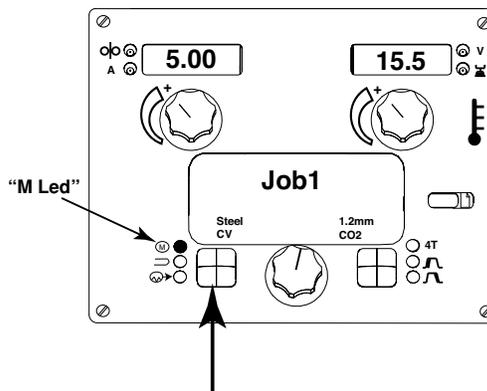

2. Rotate center knob to cycle to desired memory location.

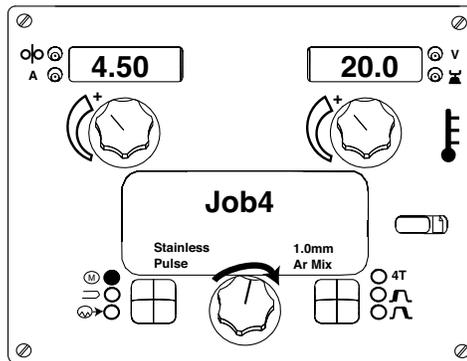

3. Press and hold center knob for 1 second. The selected memory is now active.

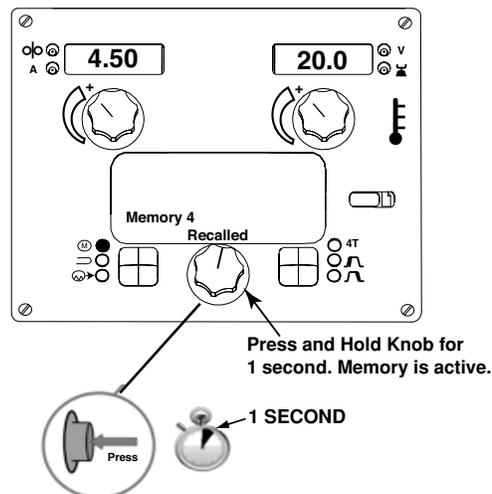

LIMITS

Limits allow the welder to adjust the welding procedure only within a defined range.

Each user memory may have a different set of limits. For example, memory 1 can be set to limit the WFS to 200 through 300 in/min, and memory 2 can be set to limit the WFS to 275 through 310 in/min, while memory 3 may not have any WFS limits.

Parameters are always constrained by machine limits. When memory limits are enabled, the parameter will flash whenever an attempt is made to exceed the memory limit value. The parameter will not flash if an attempt is made to exceed the machine limit.

The system machine limits are:

Parameter	Range	Units
Wire Feed Speed	Weld mode and wire feeder dependent.	in/min
Voltage	Weld mode dependent	Volts
Trim	0.50 to 1.50	--
UltimArc™Control	-10.0 to 10.0	Weld mode dependent
Preflow	0.0 to 2.5	Seconds
Start Time	0.0 to 10.0	Seconds
Run-In WFS	Off, 50 to 150	in/min
Crater Time	0.0 to 10.0	Seconds
Burnback Time	0.00 to 0.25	Seconds
Postflow Time	0.0 to 10.0	Seconds

Limits may be set for:

- Wire Feed Speed/Amperage
- Voltage/Trim
- UltimArc™ Control

Weld modes cannot be selected through the Limits Setup menu, and must be chosen and saved to memory before entering the Limits Setup Menu.

Press the Left Push Button until Memory 'M' LED is illuminated.

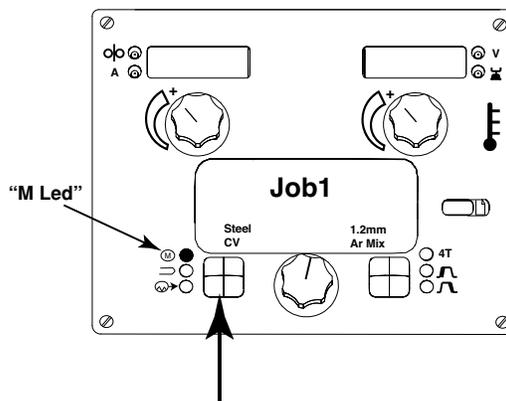

Rotate center knob to cycle to desired memory.

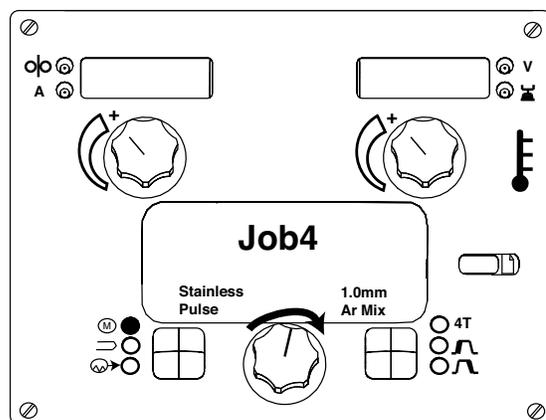

Press and hold center knob for 5 seconds. The Set Limits Menu will be active.

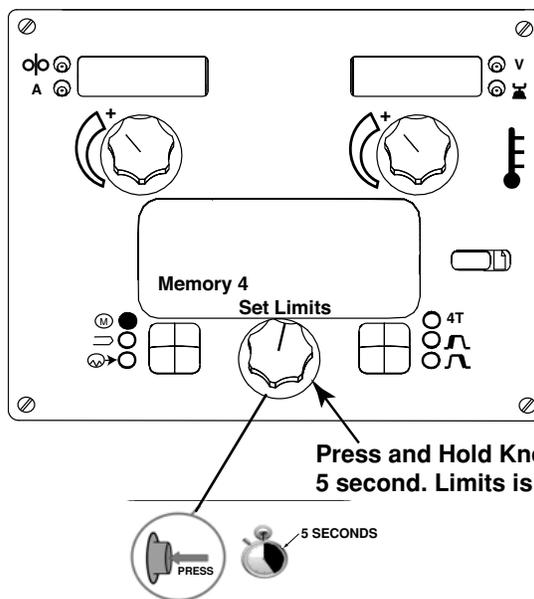

1. Rotate center knob to select parameter to be set (WFS, Voltage, Trim).

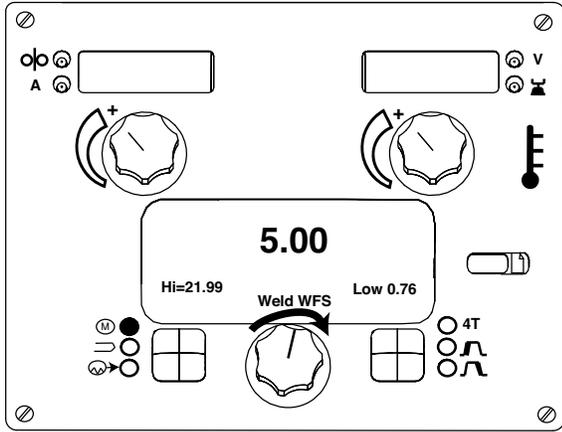

2. Press the Left pushbutton to select the limit to be set (High, Nominal, Low). The selected value will blink.

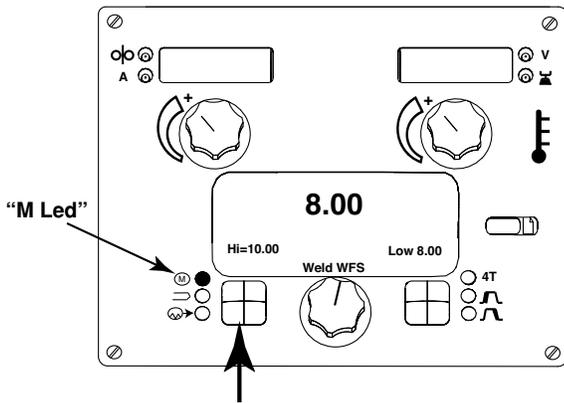

3. Once all limits have been set, press and hold for 1 second, release the center knob to accept changes.

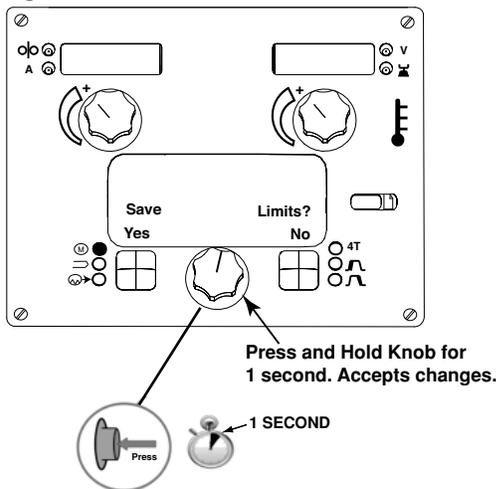

4. Press the left push button to confirm changes (or press the right push button to cancel).

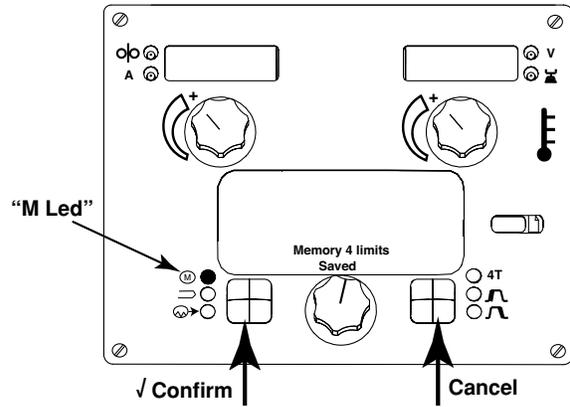

WELD MODE SEARCH

The Weld Mode search function allows for a particular mode to be selected based on the process, wire type and wire size.

1. Press the Left Push Button until Weld Mode

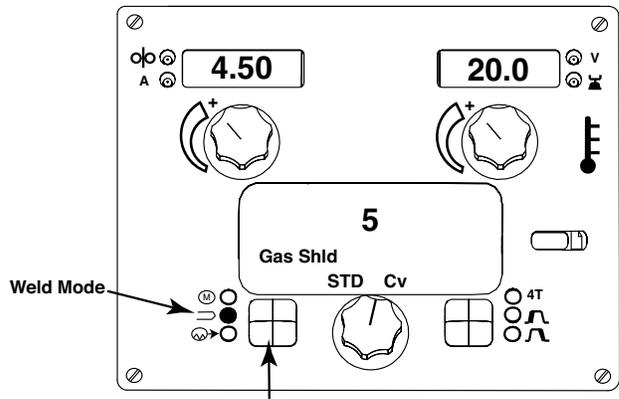

LED is illuminated.

2. Press and hold the center knob for 1 second release center knob. The Weld Mode search

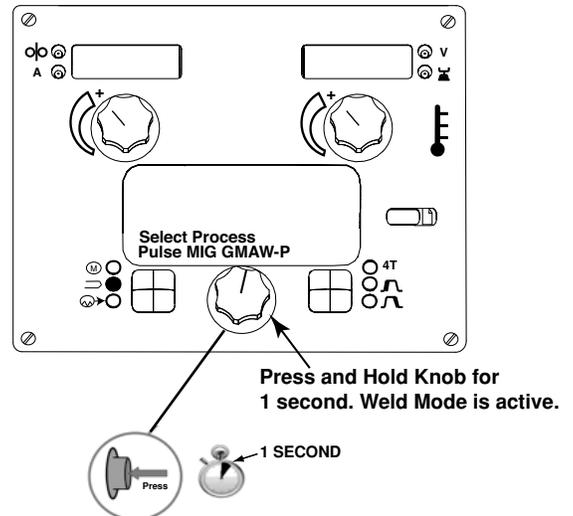

3. Rotate center knob to cycle to desired process.

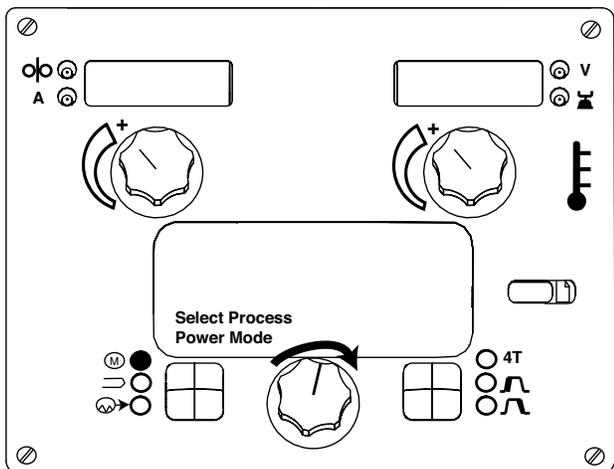

4. Press the right Push Button to select the process. If necessary, repeat steps 3 and 4 to select wire type, wire size, and final selection.

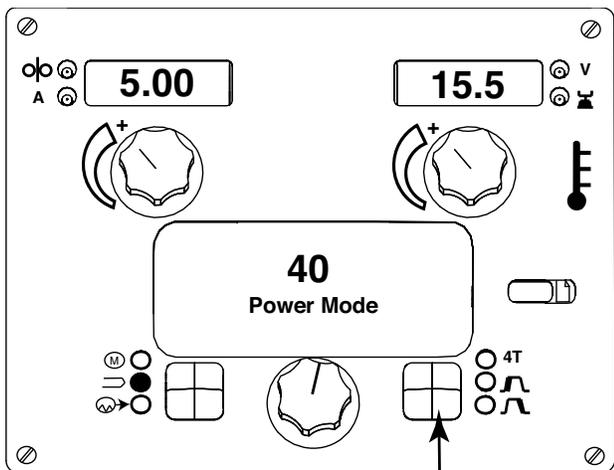

2-STEP 4-STEP- TRIGGER OPERATION

The **2-Step - 4-Step** switch changes the function of the gun trigger. **2-Step** trigger operation switches the welding output ON-OFF in direct response to the trigger. **4-Step** trigger operation provides 'trigger interlock' capability and gives the ability to control the amount of time spent in the arc start and arc crater steps.

Press the right push button on the case front to toggle between **2-Step** and **4-Step** operation.

The **2-Step, 4-Step** trigger has no effect when welding with SMAW.

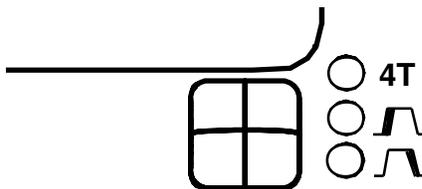

2-Step Trigger

2-Step trigger operation is the most common. When the gun trigger is pulled, the welding system (power source and wire feeder) cycles through the arc starting sequence and into the main welding parameters. The welding system will continue to weld as long as the gun trigger is activated. Once the trigger is released, the welding system cycles through the arc ending steps

4-Step Trigger

4-Step trigger operation gives the welder additional control in the welding sequence. **4-Step** trigger allows the welder to choose the arc start, weld and arc end time. It may also be set-up to work as a trigger interlock.

EXAMPLE 1 - 2 STEP TRIGGER: Simple operation
The simplest trigger operation occurs with a 2 Step trigger and the Start, Crater and Burnback functions all set to OFF. (See Figure B.11)

For this sequence,

PREFLOW:

Shielding gas begins to flow immediately when the gun trigger is pulled.

RUN-IN:

After preflow time expires, the power source regulates to the welding output and wire is advanced towards the work piece at the Run-In WFS. If an arc is not established within 1.5 seconds, the wire feed speed will jump to the welding wire feed speed

WELD:

The power source output and the wire feed speed continue at the weld settings for as long as the trigger is pulled.

POSTFLOW: As soon as the trigger is released, the power source output and the wire feed speed are turned OFF. Shielding gas continues until the post flow timer expires.

FIGURE B.11

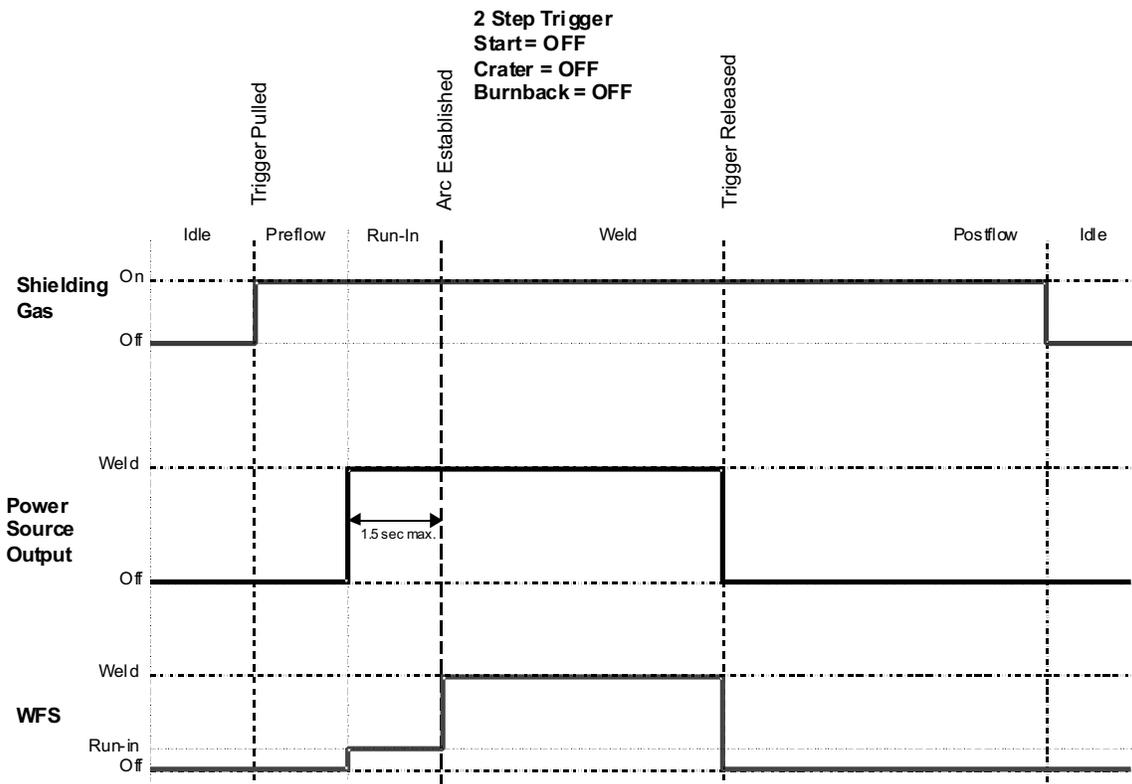

EXAMPLE 2 - 2 STEP TRIGGER: Improved Arc Start and Arc End. Tailoring the arc start and arc end is a common method for reducing spatter and improving weld quality. This can be accomplished with the Start and Burnback functions set to a desired values and Crater set to OFF. (See Figure B.12)

For this sequence,

PREFLOW:

Shielding gas begins to flow immediately when the gun trigger is pulled.

RUN-IN:

After preflow time expires, the power source regulates to the start output and wire is advanced towards the work piece at the Run-In WFS. If an arc is not established within 1.5 seconds, the power source output and wire feed speed skips to the weld settings.

UPSLOPE:

Once the wire touches the work and an arc is established, both the machine output and the wire feed speed ramp to the weld settings throughout the start time. The time period of ramping from the start settings to the weld settings is called UPSLOPE.

WELD:

After upslope, the power source output and the wire feed speed continue at the weld settings.

BURNBACK:

As soon as the trigger is released, the wire feed speed is turned OFF and the machine output continues for the burnback time.

POSTFLOW:

Next, the machine output is turned OFF and shielding gas continues until the post flow timer expires.

FIGURE B.12

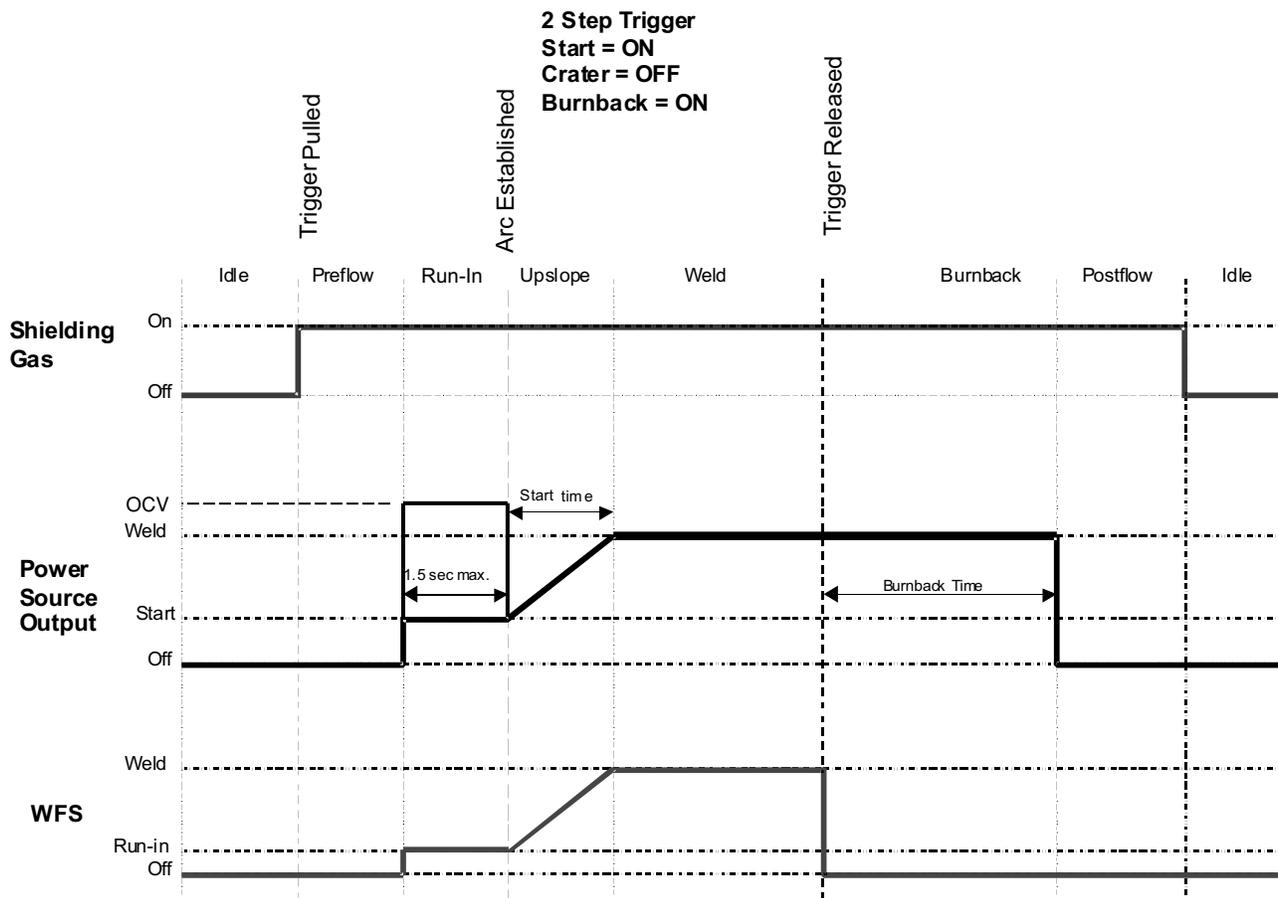

EXAMPLE 3 - 2 STEP TRIGGER: Customized Arc Start, Crater and Arc End. Sometimes it is advantageous to set specific arc start, crater and arc ending parameters for the ideal weld. Many times when welding aluminum crater control is necessary to make a good weld. This is done by setting Start, Crater and Burnback functions to desired values. (See Figure B.13)

For this sequence,

PREFLOW:

Shielding gas begins to flow immediately when the gun trigger is pulled.

RUN-IN:

After preflow time expires, the power source regulates to the start output and wire is advanced towards the work piece at the Run-In WFS. If an arc is not established within 1.5 seconds, the power source output and wire feed speed skips to the weld settings.

START & UPSLOPE:

As soon as the trigger is pulled, this starts preflow. The Strike arc established, Start time, and Upslope parameters are used at the beginning of the weld sequence to establish a stable arc and provide a smooth transition to the weld settings.

WELD:

After upslope, the power source output and the wire feed speed continue at the weld settings.

CRATER & DOWNSLOPE:

As soon as the trigger is released, the wire feed speed and power source output ramp to the crater settings throughout the crater time. The time period of ramping from the weld settings to the crater settings is called DOWNSLOPE.

BURNBACK:

After the crater time expires, the wire feed speed is turned OFF and the machine output continues for the burnback time.

POSTFLOW:

Next, the machine output is turned OFF and shielding gas continues until the post flow timer expires.

FIGURE B.13

2 Step Trigger
Start = ON
Crater = ON
Burnback = ON

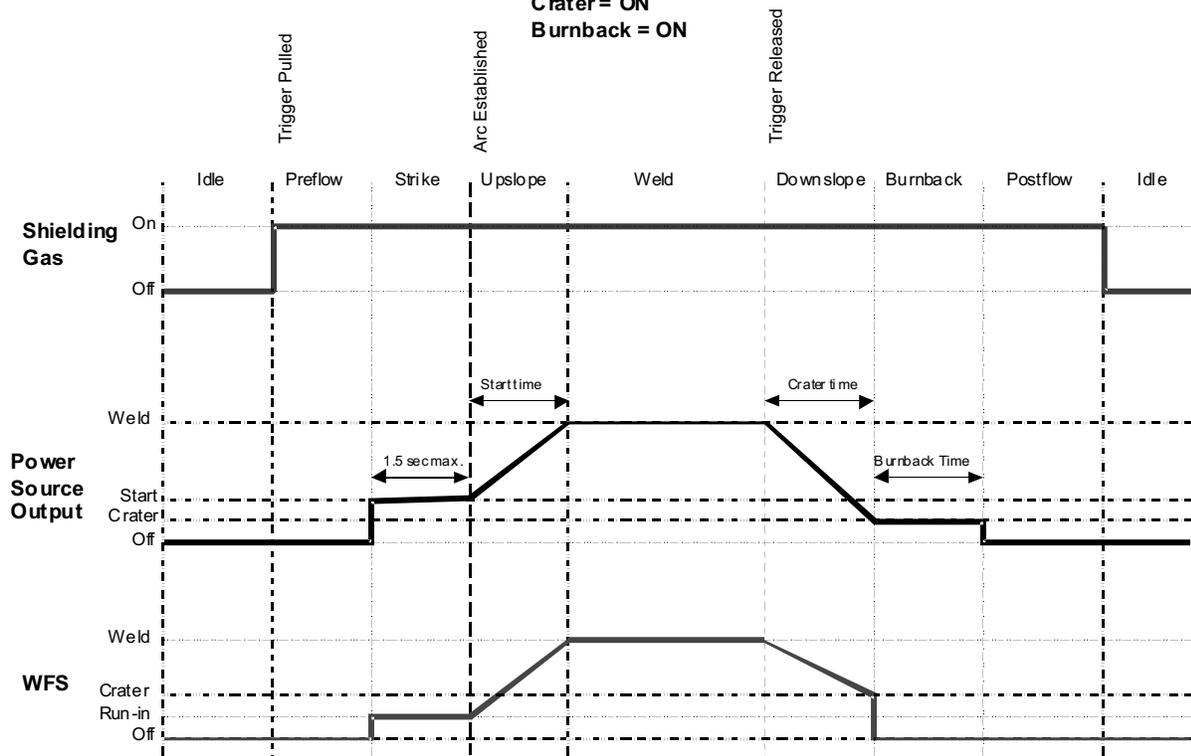

EXAMPLE 4 – 4 STEP TRIGGER: Trigger Interlock

The 4 step trigger can be configured as a trigger interlock. Trigger interlock adds to the welder’s comfort when making long welds by allowing the trigger to be released after an initial trigger pull. Welding stops when the trigger is pulled a second time and then released, or if the arc is interrupted. (See Figure B.14)

For this sequence,

PREFLOW:

Shielding gas begins to flow immediately when the gun trigger is pulled.

RUN-IN:

After preflow time expires, the power source regulates to the welding output and wire is advanced towards the work piece at the Run-In WFS. If an arc is not established within 1.5 seconds, the wire feed speed will jump to the welding wire feed speed.

WELD:

The power source output and the wire feed speed continue at the weld settings. Welding continues when the trigger is pulled a second time.

POSTFLOW:

As soon as the trigger is released for the second time, the power source output and the wire feed speed are turned OFF. Shielding gas flows until the post flow timer expires.

FIGURE B.14

4 Step Trigger
 Start = OFF
 Crater = OFF
 Burnback = OFF

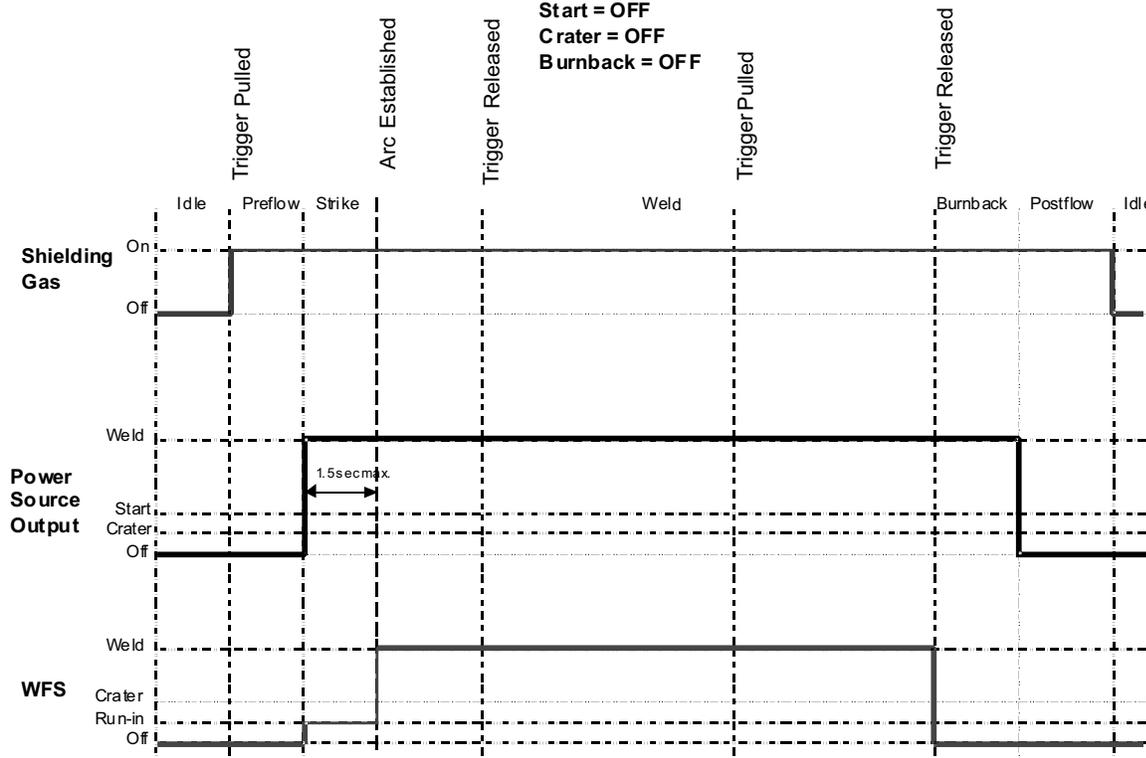

EXAMPLE 5 - 4 STEP TRIGGER: Manual control of Start and Crater times with Burnback ON. The 4 step trigger sequence gives the most flexibility when the Start, Crater and Burnback functions are active. This is a popular choice when welding aluminum because extra heat may be needed during Start and less heat desired during crater. With 4 step trigger, the welder chooses the amount of time to weld at the Start, Weld and Crater settings by using the gun trigger. Burnback reduces the occurrence of wire to sticking into the weld pool at the end of a weld and conditions the end of the wire for the next arc start. (See Figure B.15)

In this sequence,

PREFLOW:

Shielding gas begins to flow immediately when the gun trigger is pulled.

RUN-IN:

After preflow time expires, the power source regulates to the start output and wire is advanced towards the work piece at the run-in WFS. If an arc is not established within 1.5 seconds, the power source output and wire feed speed skips to the weld settings.

START:

The power source welds at the start WFS and voltage until the trigger is released.

UPSLOPE:

During upslope, the power source output and the wire feed speed ramp to the weld settings throughout the start time. The time period of ramping from the start settings to the weld settings is called UPSLOPE.

WELD:

After upslope, the power source output and the wire feed speed continue at the weld settings.

DOWNSLOPE:

As soon as the trigger is pulled, the wire feed speed and power source output ramp to the crater settings throughout the crater time. The time period of ramping from the weld settings to the crater settings is called DOWNSLOPE.

CRATER:

During CRATER, the power source continues to supply output at the crater WFS and voltage.

BURNBACK:

When the trigger is released, the wire feed speed is turned OFF and the machine output continues for the burnback time.

POSTFLOW:

Next, the machine output is turned OFF and shielding gas continues until the post flow timer expires.

FIGURE B.15

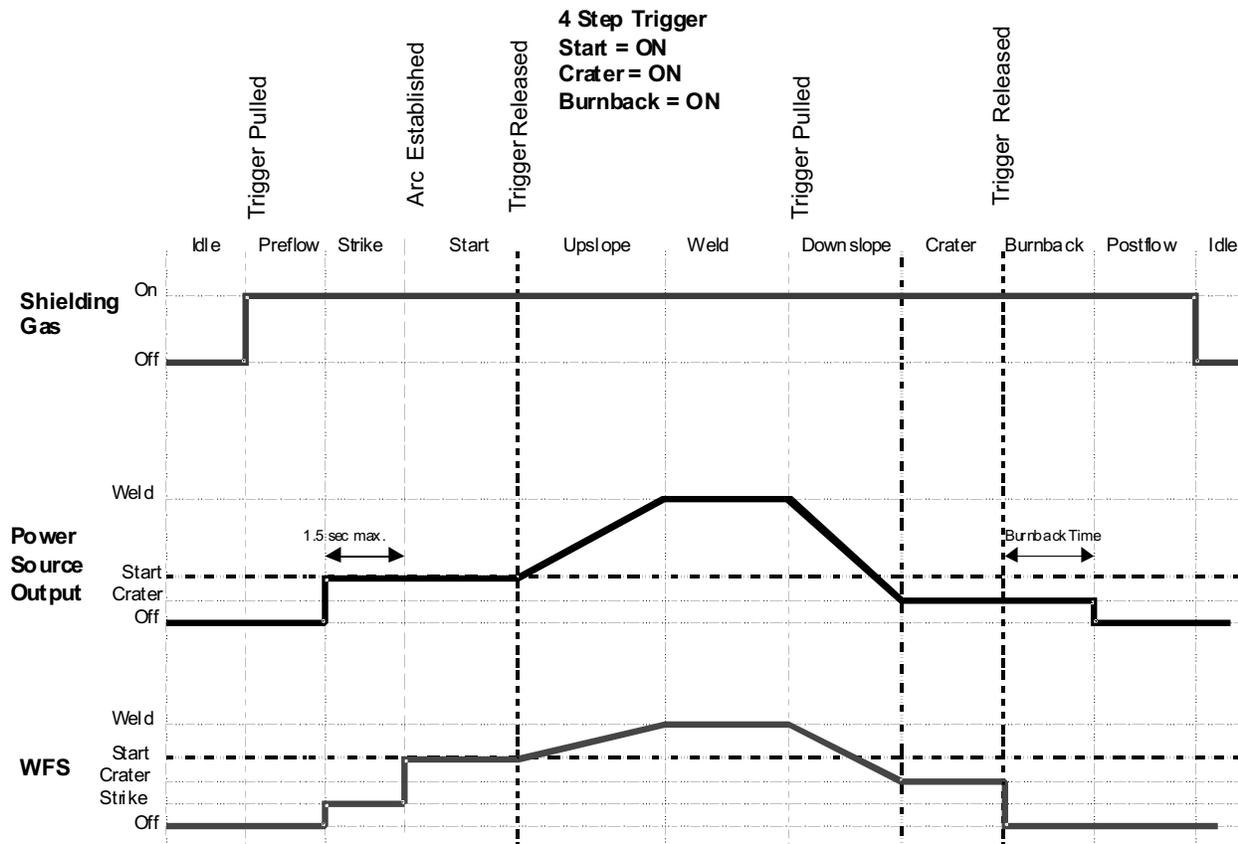

POWER WAVE® C300 CE



COLD FEED/GAS PURGE SWITCH

Cold Feed and Gas Purge are combined into a single spring centered toggle switch.



To activate Cold Feeding, hold the switch in the **UP** position. The wire drive will feed electrode but neither the power source nor the gas solenoid will be energized. Adjust the speed of cold feeding by rotating the WFS knob. Cold feeding, or "cold inching" the electrode is useful for threading the electrode through the gun.

Hold with toggle switch in the **DOWN** position to activate Gas Purge and let the shielding gas flow. The gas solenoid valve will energize but neither the power source output nor the drive motor will be turned on. The Gas Purge switch is useful for setting the proper flow rate of shielding gas. Flow meters should always be adjusted while the shielding gas is flowing.

PUSH / PULL OPERATION

- Set the idle roll pressure on the wire drive between an indicator reading of 0-2. A recommended start point is 1.5.
- Configure the machine for push/pull operation (see parameter **P.17** in the Set-up Menu section).
- Depending on the weld mode, set the Voltage or Trim at the Power Wave® C300 CE using the right control knob located on the upper case front panel.
- The Wire Feed Speed (WFS) is set using the control knob on the Torch. The left control knob on the Power Wave® C300 CE is inactive. The actual WFS being set at the torch is displayed on the Power Wave® C300 CE.
- All weld parameters normally available for the active weld mode are available during push-pull operation. Refer to the Operation Section of this manual.

SETUP MENU FEATURES

The Setup Menu gives access to the Setup Configuration. Stored in the setup configuration are user parameters that generally only need to be set at installation. The parameters are grouped as shown in the following table.

PARAMETER	DEFINITION
P.1 through P.99	Unsecured Parameters (always adjustable)
P.101 through P.199	Diagnostic Parameters (always read only)
P.501 through P.599	Secured Parameters (only accessible through a p.c. or palm application)

SET-UP FEATURES MENU

(See Figure B.16)

1. To access the set-up menu, press the **Right** and **Left** buttons of the **Main Display** panel simultaneously. **Note** that the set-up menu cannot be accessed if the system is welding, or if there is a fault (The status **LED** is not solid green).

Change the value of the blinking parameter by rotating the **SET** knob.

2. After changing a parameter it is necessary to press the **Right** hand button to save the new setting. Pressing the **Left** button will cancel the change.

3. To exit the set-up menu at any time, press the **Right** and **Left** buttons of the Main Display panel simultaneously. Alternately, 1 minute of inactivity will also exit the set-up menu.

FIGURE B.16 - SETUP MENU

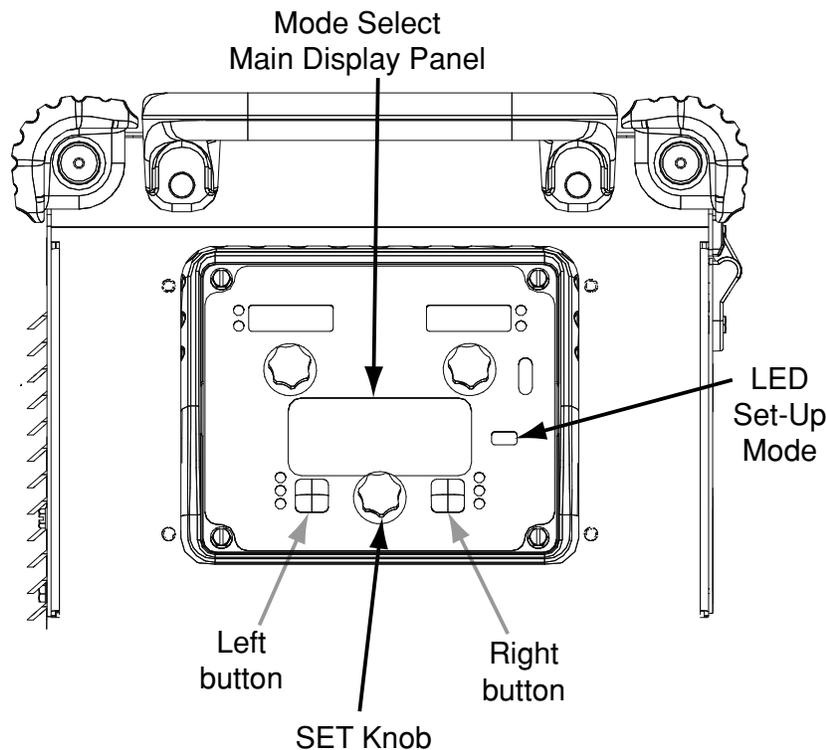

POWER WAVE® C300 CE



USER DEFINED PARAMETERS

Parameter	Definition
P.0	<p>Exit Setup Menu</p> <p>This option is used to exit the setup menu. When P.0 is displayed, press the Left Button to exit the setup menu.</p>
P.1	<p>Wire Feed Speed Units</p> <p>This option selects which units to use for displaying wire feed speed. English = inches/minute wire feed speed units (default). Metric = meters/minute wire feed speed units.</p>
P.2	<p>Arc Display Mode</p> <p>This option selects what value will be shown on the upper left display while welding. Amps = The left display shows Amperage while welding (default). WFS = The left display shows Wire Feed Speed while welding.</p>
P.3	<p>Display Options</p> <p>This setup parameter was previously named "Display Energy"</p> <p>If the previous software revision had this parameter set to display energy, that selection will remain.</p> <p>This option selects the information displayed on the alphanumeric displays while welding. Not all P.3 selections will be available on all machines. In order for each selection to be included in the list, the power source must support that feature. A software update of the power source may be needed to include the features.</p> <p>Standard Display = The lower displays will continue to show preset information during and after a weld (default). Show Energy = Energy is displayed, along with time in HH:MM:SS format. Show Weld Score = The accumulative weld score result is shown.</p>
P.4	<p>Recall Memory with Trigger</p> <p>This option allows a memory to be recalled by quickly pulling and releasing the gun trigger. To recall a memory, quickly pull and release the trigger the number of times that correspond to the memory number. For example, to recall memory 3, quickly pull and release the trigger 3 times. To recall memory 1, quickly pull and release the trigger the number of user memories plus 1. Memories cannot be recalled while the system is welding. Disabled = The gun trigger cannot be used to recall user memories (default). Enabled = The gun trigger can be used to recall user memories.</p>

USER DEFINED PARAMETERS

Parameter	Definition
P.5	<p>Procedure Change Method</p> <p>This option selects how remote procedure selection (A/B) will be made. For some products the selected procedure can be changed locally at the user interface by pressing the 'A-Gun-B' button. Other products do not have this button and must use a Cross-switch gun or wire into the procedure select input. The following methods can be used to remotely change the selected procedure:</p> <p>LF45 and C300CE:</p> <p>Quick Trigger = Allows switching between Procedure A and procedure B while welding with 2-stroke mode. The Cross-switch gun or remote control is required. To operate:</p> <ul style="list-style-type: none"> • Select "Procedure A/B" in P.25 to set up parameters for A and B procedures. • Start the weld by pulling the gun trigger. The system will weld with procedure A settings. • While welding, quickly release and then pull the gun trigger. The system will switch to procedure B settings. Repeat to switch back to procedure A settings. The procedure can be changed as many times as needed during the weld. • Release the trigger to stop welding. When the next weld is made, the system will start again with procedure A. <p>IntegralTrigProc = Allows switching between Procedure A and procedure B while welding with 4-stroke mode. When in 2-step, the system operates identical to the External Switch selection. To operate in 4-step:</p> <ul style="list-style-type: none"> • Select "Procedure A/B" in P.25 to set up parameters for A and B procedures. • Start the weld by pulling the gun trigger. The system will weld with procedure A settings. • While welding, quickly release and then pull the gun trigger. The system will switch to procedure B settings. • Release the trigger to stop welding. When the next weld is made, the system will start again with procedure A. <p>External Switch = Dual Procedure selection may only be performed by the Cross-switch gun or remote control (default).</p> <p>All Other Products:</p> <p>External Switch = Dual Procedure selection may only be performed at the memory panel or an external switch (e.g. K683).</p> <p>Quick Trigger = The selected procedure can be changed remotely by releasing and re-pulling the trigger quickly while welding. This feature is disabled in 4-Step trigger mode. The external procedure switch is disabled. To operate:</p> <ul style="list-style-type: none"> • Select "GUN" on the memory panel (for products that have an 'A-Gun-B' button). • Start the weld by pulling the gun trigger. The system will weld with procedure A settings. • While welding, quickly release then pull the gun trigger once. The system will switch to procedure B settings. Repeat to switch back to procedure A settings. The procedure can be changed as many times as needed during the weld. • Release the trigger to stop welding. The system will automatically return to procedure A settings. <p>IntegralTrigProc = When using a Magnum DS dual-schedule gun (or similar) that incorporates a procedure switch in the gun trigger mechanism. While welding in 2-step, machine operation is identical to the "External Switch" selection. When welding in 4-step, additional logic prevents procedure A from being re-selected when the trigger is released at step 2 of the 4-step weld sequence. The machine will always operate in 2-step if a weld is made exclusively in procedure A, regardless of the 2/4 step switch position (this is intended to simplify tack welding when using a dual-schedule gun in 4-step).</p>

USER DEFINED PARAMETERS

Parameter	Definition
P.7	<p>Gun Offset Adjustment</p> <p>This option adjusts the wire feed speed calibration of the pull motor of a push-pull gun. This should only be performed when other possible corrections do not solve any push-pull feeding problems. An rpm meter is required to perform the pull gun motor offset calibration. To perform the calibration procedure do the following:</p> <ol style="list-style-type: none"> 1. Release the pressure arm on both the pull and push wire drives. 2. Set the wire feed speed to 200 ipm. 3. Remove wire from the pull wire drive. 4. Hold an rpm meter to the drive roll in the pull gun. 5. Pull the trigger on the push-pull gun. 6. Measure the rpm of the pull motor. The rpm should be between 115 and 125 rpm. If necessary, decrease the calibration setting to slow the pull motor, or increase the calibration setting to speed up the motor. <p>The calibration range is -30 to +30, with 0 as the default value.</p> <p>Note: The range was changed to -90 to +90 for the PF25M in WD software S28539-3. Default value remains at 0.</p>
P.8	<p>TIG Gas Control</p> <p>This option allows control over which gas solenoid actuates while TIG welding.</p> <p>"Valve (manual)" = No MIG solenoid will actuate while TIG welding, gas flow is manually controlled by an external valve.</p> <p>"Solenoid (auto)" = This selection only applicable to PWC300. The MIG solenoid will turn on and off automatically while TIG welding.</p> <p>"Feeder Solenoid" = No applicable to PWC300. The internal (feeder) MIG solenoid will turn on and off automatically while TIG welding.</p> <p>"Pwr Src Solenoid" = Not applicable to PWC300. Any gas solenoid connected to the power source will turn on and off automatically while TIG welding. This selection will not appear in the list if the power source does not support a gas solenoid.</p> <p>Notes: Preflow is not available while TIG welding. Postflow is available - the same postflow time will be used in MIG and TIG. When machine output on/off is controlled via the upper right knob, gas flow will not start until the tungsten touches the work. Gas flow will continue when the arc is broken until the Postflow time expires. When machine output on/off is controlled via an arc start switch or foot Amptrol, gas will begin flowing when the output is turned on and will continue flowing until the output is turned off and the Postflow time expires.</p>
P.9	<p>Crater Delay</p> <p>This option is used to skip the Crater sequence when making short tack welds. If the trigger is released before the timer expires, Crater will be bypassed and the weld will end. If the trigger is released after the timer expires, the Crater sequence will function normally (if enabled).</p>
P.14	<p>Reset Consumable Weight</p> <p>Use this option to reset the initial weight of the consumable package. Press the Right Button to reset the consumable weight. This option will only appear with systems using Production Monitoring.</p>

USER DEFINED PARAMETERS

Parameter	Definition
P.16	<p>Push-Pull Gun Knob Behavior</p> <p>This option determines how the potentiometer on the Push/Pull torch will behave. Gun Pot Enabled = The welding wire feed speed is always controlled by the potentiometer on the push-pull gun (default). The left front panel knob is only used to adjust Start and Crater wire feed speed.</p> <p>Gun Pot Disabled = The wire feed speed is always controlled by the left front panel knob. This setting is useful when the operator wishes to have wire feed speed settings recalled from memories and not have the potentiometer "overwrite" the setting.</p> <p>Gun Pot Proc A = When in procedure A, the welding wire feed speed is controlled by the potentiometer on the push-pull gun. When in procedure B, the welding wire feed speed is controlled by the left front panel knob. This setting allows a fixed wire feed speed to be selected in procedure B and not have the potentiometer "overwrite" the setting when the procedure changes.</p>
P.17	<p>Remote Control Type</p> <p>This setup parameter was previously named "Spool/Push-Pull".</p> <p>This option selects the type of analog remote control being used. Digital remote control devices (those with a digital display) are configured automatically. Not all P.17 selections will be available on all machines. When P.17 is used to configure the remote control to function in a specific process, the remote will be ignored in other processes. For example, if P.17 = TIG Amp Control, the remote control will only function when TIG welding - the remote will be ignored in other processes (MIG, stick and gouge). If P.17 is set to Spool Gun or Push-Pull Gun then set to All Mode Remote, the machine will remember prior value of P.17 and will operate a Spool Gun or Push-Pull Gun, depending on the prior value of P.17.</p> <p>Spool Gun = Use this setting while MIG welding with a spool gun that uses a potentiometer used for wire feed speed control (this setting is backward compatible with "P.17 Gun Selection" = Standard/Spool).</p> <p>Push-Pull Gun = Use this setting while MIG welding with a push-pull gun that uses a potentiometer for wire feed speed control (this setting is backward compatible with "P.17 Gun Selection" = PushPull).</p> <p>TIG Amp Control = Use this setting while TIG welding with a foot or hand current control device (Amptrol). While TIG welding, the upper left knob on the User Interface sets the maximum current obtained when the TIG amp control is at its maximum setting.</p> <p>Stick/Gouge Rem. = Use this setting while stick welding or gouging with a remote output control device. While stick welding, the upper left knob on the User Interface sets the maximum current obtained when the stick remote is at its maximum setting. While gouging, the upper left knob is disabled and the gouging current is set on the remote control.</p> <p>All Mode Remote = This setting allows the remote control to function in all weld modes which is how most machines with 6-pin and 7-pin remote control connections operate. This setting was provided so that customers with a mix of Lincoln Electric equipment can have consistent remote control behavior across all of their equipment. (N. American default)</p> <p>Joystick MIG Gun = Use this setting while MIG welding with a push MIG gun with a joystick control. Stick, TIG and gouge welding currents are set at the User Interface. (European default)</p>
P.20	<p>Display Trim as Volts Options</p> <p>This option determines how trim is displayed.</p> <p>False = The trim is displayed in the format defined in the weld set (default).</p> <p>True = All trim values are displayed as a voltage.</p> <p>Note: This option may not be available on all machines. The power source must support this functionality, or this option will not appear in the menu. Note: This option may not be available on all machines. The power source must support this functionality, or this option will not appear in the menu.</p>

USER DEFINED PARAMETERS

Parameter	Definition
P.22	<p>Arc Start/Loss Error Time</p> <p>This option can be used to optionally shut off output if an arc is not established, or is lost for a specified amount of time. Error 269 will be displayed if the machine times out. If the value is set to OFF, machine output will not be turned off if an arc is not established nor will output be turned off if an arc is lost. The trigger can be used to hot feed the wire (default). If a value is set, the machine output will shut off if an arc is not established within the specified amount of time after the trigger is pulled or if the trigger remains pulled after an arc is lost. This is disabled while welding in Stick, TIG or Gouge. To prevent nuisance errors, set Arc Start/Loss Error Time to an appropriate value after considering all welding parameters (run-in wire feed speed, weld wire feed speed, electrical stick out, etc). To prevent subsequent changes to Arc Start/Loss Error Time, the setup menu should be locked out by setting Preference Lock = Yes using the Power Wave Manager software.</p>
P.24	<p>Push Pull Type</p> <p>Allows operator to choose the Prince option if welding with a Prince Push Pull gun. This gun requires unique settings to run at the correct WFS.</p> <p>Note: This option may not be available on all machines. The wire drive must support this functionality, or this option will not appear in the menu.</p>
P.25	<p>Joystick Configuration</p> <p>The new analog and digital gun controls have a joystick to allow the user to change various weld settings at the gun rather than having to go to the user interface. P.25 can be used to change the behavior of the joystick.</p> <p>When P.25 is set to "Disable Joystick", the joystick does not function.</p> <p>In all configurations other than "Disable Joystick", the up and down joystick positions will adjust the wire feed speed, while welding and while not welding. P.25 is used to reconfigure the behavior of the left and right joystick positions.</p> <p>When P.25 is set to "WFS/Trim", the left and right joystick positions will adjust Arc Length Trim, Arc Voltage, Power or STT Background Current based on the selected weld mode. For example, when a non-synergic STT weld mode is selected, the left and right joystick positions will adjust Background Current. When a Power mode is selected, the left and right joystick positions will adjust the Power (kW).</p> <p>When P.25 is set to "WFS/Job (Memory)", the left and right joystick positions will select a user memory while not welding and adjust Trim/Voltage/Power/STT Background Current while welding.</p> <p>When P.25 is set to "WFS/Proced. A-B", the left and right joystick positions will be used to select procedure A and B, while welding and while not welding. The left joystick position selects procedure A, the right joystick position selects procedure B.</p>
P.26	<p>Show Memory LED</p> <p>On user interfaces that support user memories but do not have dedicated user memory buttons, this parameter is used to show or hide the LED that is used to select a user memory to save to or recall from. When P.26 is set to Yes, the user memory LED will be shown and the operator can save to and recall from user memories. When P.26 is set to No, the user memory LED will not be shown, preventing the operator from saving to and recalling from user memories.</p>

USER DEFINED PARAMETERS

Parameter	Definition						
P.27	<p>Language Select Selects which language will be displayed on the User Interface.</p> <table data-bbox="341 283 820 388"> <tr> <td>English (Default)</td> <td>Italiano</td> </tr> <tr> <td>Deutsch</td> <td>Francais</td> </tr> <tr> <td>Polski</td> <td>Espanol</td> </tr> </table>	English (Default)	Italiano	Deutsch	Francais	Polski	Espanol
English (Default)	Italiano						
Deutsch	Francais						
Polski	Espanol						
P.28	<p>Display Workpoint as Amps Option This option determines how workpoint is displayed. False = The workpoint is displayed in the format defined in the weld set (default). True = All workpoint values are displayed as an amperage.</p> <p>Note: This option may not be available on all machines. The power source must support this functionality, or this option will not appear in the menu.</p>						
P.29	<p>Feedback Persist This option determines how feedback values are displayed following a weld. False = Last recorded feedback values will blink for 5 seconds following a weld, then return to pre-set display mode (default). True = Last recorded feedback values will blink indefinitely following a weld until a knob or button is touched, or an arc is struck.</p>						
P.80	<p>Sense From Studs Use this option for diagnostic purposes only. When power is cycled, this option is automatically reset to False. False = Voltage sensing is automatically determined by the selected weld mode and other machine settings (default). True = Voltage sensing is forced to "studs".</p>						
P.82	<p>Voltage Sense Display Allows viewing of Voltage Sense Lead Selection to aid in troubleshooting. The configuration is displayed as a text string on the lower display whenever the output is enabled. This parameter is not saved on a power cycle, but will be reset to False.</p>						
P.99	<p>Show Test Modes? Most power sources contain weld modes used for calibration and test purposes. By default, the machine does not include test weld modes in the list of weld modes that are available to the operator. To manually select a test weld mode, set this option to "Yes". When the power source is turned off and back on again, the test modes will no longer appear in the mode list. Test weld modes typically require the machine output to be connected to a grid load and cannot be used for welding.</p>						
P.100	<p>View Diagnostic? Diagnostics are only used for servicing or troubleshooting the Power Wave system. Select "Yes" to access the diagnostic options in the menu. Additional parameters will now appear in the setup menu (P.101, P.102, etc).</p>						
P.101	<p>View Event Logs Used for viewing all the system event logs. Press the Right Button to enter the option. Rotate Control Knob to select the desired event log to read. Press the Right Button again to enter the selected log. Rotating the Control Knob will scroll through the event log, displaying the log index number, event code and some other data. Press the Left Button to back out to select another log. Press the Left Button again to exit this option.</p>						

USER DEFINED PARAMETERS

Parameter	Definition
P.102	<p>View Fatal Logs</p> <p>Used for viewing all the system fatal logs. Press the Right Button to enter the option. Rotate Control Knob to select the desired fatal log to read. Press the Right Button again to enter that log. Rotating the Control Knob will scroll through the log, displaying the log index number and fatal code. Press the Left Button to back out to select another log. Press the Left Button again to exit this option.</p>
P.103	<p>View Software Version Information</p> <p>Used for viewing the software versions for each board in the system. Press the Right Button to enter the option. Rotate Control Knob to select the desired board to read. Press the Right Button again to read the firmware version. Press the Left Button to back out to select another board. Rotate the Control Knob to select another board, or press the Left Button to exit this option.</p>
P.104	<p>View Hardware Version Information</p> <p>Used for viewing the hardware version for each board in the system. Press the Right Button to enter the option. Rotate Control Knob to select the desired board to read. Press the Right Button again to read the hardware version. Press the Left Button to back out to select another board. Press the Left Button again to exit this option.</p>
P.105	<p>View Welding Software Information</p> <p>Used for viewing the Weld Set in the Power Source. Press the Right Button to read the Weld Set version. Press the Left Button to back out and exit this option.</p>
P.106	<p>View Ethernet IP Address</p> <p>Used for viewing the IP address of Ethernet compatible equipment. Press the Right Button to read the IP Address. Press the Left Button to back out and exit this option. The IP address cannot be changed using this option.</p>
P.107	<p>View Power Source Protocol</p> <p>Used for viewing the type of power source the feeder is connected to. Press the Right Button to identify the power source as either LincNet or ArcLink. Press the Left Button to back out and exit this</p>
P.500	<p>View Lockout Parameters</p> <p>Originally used to prevent inadvertent changes of secure setup parameters, P.500 was previously used as a gateway to these parameters. Presently, this option does not exist in any setup menu.</p>
P.501	<p>Encoder Lockout</p> <p>Locks one or both of the upper knobs (encoders), preventing the operator from changing wire feed speed, amps, volts or trim. The function of each upper knob depends on the selected weld mode. When a constant current weld mode is selected (e.g. Stick, TIG, Gouge), the upper right knob will always function as an on/off switch. This parameter can only be accessed using Power Wave Manager software.</p>

USER DEFINED PARAMETERS

Parameter	Definition
P.502	<p>Memory Change Lockout</p> <p>Determines if the memories can be overwritten with new contents. No = Memories can be saved and limits can be configured (default). Yes = Memories cannot be changed - saving is prohibited and limits cannot be re-configured. This parameter can only be accessed using Power Wave Manager software.</p>
P.503	<p>Memory Button Disable</p> <p>Disables the specified memory button(s). When a memory is disabled, welding procedures cannot be restored from or saved to that memory. If an attempt is made to save or restore a disabled memory, a message will be displayed on the lower display indicating the memory number is disabled. In multi-head systems, this parameter disables the same memory buttons on both feed heads. This parameter can only be accessed using Power Wave Manager software.</p>
P.504	<p>Mode Select Panel Lock</p> <p>Selects between several Mode Select Panel lockout preferences. When a Mode Select Panel selection is locked and an attempt is made to change that parameter, a message will be displayed on the lower display indicating the parameter is locked.</p> <ul style="list-style-type: none"> • All MSP Options Unlocked = All adjustable parameters on the Mode Select Panel are unlocked. • All MSP Options Locked = All knobs and buttons on the Mode Select Panel are locked. • Start and End Options Locked = The Start and End parameters on the Mode Select Panel are locked, all others are unlocked. • Weld Mode Option Locked = The weld mode cannot be changed from the Mode Select Panel, all others Mode Select Panel settings are unlocked. • Wave Control Options Locked = The Wave Control parameters on the Mode Select Panel are locked, all others are unlocked. • Start, End, Wave Options Locked = The Start, End and Wave Control parameters on the Mode Select Panel are locked, all others are unlocked. • Start, End, Mode Options Locked = The Start, End and Weld Mode Select parameters on the Mode Select Panel are locked, all others are unlocked. • This parameter can only be accessed using Power Wave Manager software.
P.505	<p>Setup Menu Lock</p> <p>Determines if the setup parameters can be modified by the operator without entering a passcode. No = The operator can change any set menu parameter without first entering the passcode even if the passcode is non-zero (default). Yes = The operator must enter the passcode (if the passcode is non-zero) in order to change any setup menu parameters. This parameter can only be accessed using Power Wave Manager software.</p>
P.506	<p>Set User Interface Passcode</p> <p>Prevents unauthorized changes to the equipment. The default passcode is zero which allows full access. A nonzero passcode will prevent unauthorized: changes to memory limits, saving to memory (if P.502 = Yes), changes to setup parameters (if P.505 = Yes). This parameter can only be accessed using Power Wave Manager software.</p>
P.509	<p>UI Master Lockout</p> <p>Locks all user interface controls, preventing the operator from making any changes. This parameter can only be accessed using Power Wave Manager software.</p>

OPTIONS / ACCESSORIES

K857 REMOTE OUTPUT CONTROL

Portable current control provides the same dial range as the current control on the welder. Consists of a 6-pin Amphenol connector which plugs into the remote control Amphenol. 25 foot cable length.



TIG OPTIONS

Lincoln Electric offers a full line of **TIG Torches**. Contact your local Lincoln Electric sales office for more information.



K870 FOOT AMP TROL *

Depress pedal to increase current. Depressing pedal fully achieves maximum set current. Fully raising the pedal finishes the weld and starts the Afterflow cycle.



K963-3 HAND AMP TROL *

Provides 25 ft (7.6m) of remote current control for TIG welding. (6-pin plug connection).



K814 ARC START SWITCH (25FT., 7.6m)*

CUT LENGTH CONSUMABLES

TIG welding filler metals are available for welding stainless steel, mild steel, aluminum and copper alloys.



* Requires K2909-1
12 pin - 6 pin Remote Adapter Cable

WIRE FEEDER OPTIONS

K2490-1 MAGNUM® 250LX SPOOL GUN

Air-Cooled, 25 ft. 280 amps, 60% duty cycle Feeds .025"-3/64" (0.6-1.2mm) diameter aluminum wire on 2lbs. (0.9kg.) spool.



The Magnum 250LX spool gun is a professional grade solution for feeding small spools of aluminum and steel wire.

K2519-1 CONTROL CABLE EXTENSION

Extend your spool gun reach with a 25 ft. (7.5 m) control cable extension. Features a 7-pin female MS-type connector on the spool gun end and a 7-pin male MS-type connector on the power source end.



PUSH PULL GUNS

Lincoln Electric offers both the **Cougar™** pistol grip and **Panther™** gooseneck style push-pull guns for feeding aluminum wire. Both **Air** and **Water** cooled versions are available. Contact your local Lincoln Electric sales office for more information.

K1738-1 SPOOL GUN HOLDER

K2378-1 CANVAS COVER

K2734-1 POWER WAVE® C300 CE CART

WELD FUME EXTRACTORS

Lincoln Electric's® WELD FUME EXTRACTORS are portable, low vacuum/high volume self-cleaning filtration system designed for heavy duty extraction and filtration of welding fumes. Easily wheeled around the shop-wide central systems servicing many welding stations.



SAFETY PRECAUTIONS

WARNING

ELECTRIC SHOCK can kill.



- Do not operate with covers removed.
 - Turn off power source before installing or servicing.
 - Do not touch electrically hot parts.
-
- Turn the input power to the welding power source off at the fuse box before working in the terminal strip.
 - Only qualified personnel should install, use or service this equipment.
-

ROUTINE MAINTENANCE

Routine maintenance consists of periodically blowing out the machine, using a low-pressure air stream, to remove accumulated dust and dirt from the intake and outlet louvers, and the cooling channels in the machine.

PERIODIC MAINTENANCE

Calibration of the POWER WAVE® C300 CE is critical to its operation. Generally speaking the calibration will not need adjustment. However, neglected or improperly calibrated machines may not yield satisfactory weld performance. To ensure optimal performance, the calibration of output Voltage and Current should be checked yearly.

CALIBRATION SPECIFICATION

Output Voltage and Current are calibrated at the factory. Generally the machine calibration will not need adjustment. However, if the weld performance changes, or the yearly calibration check reveals a problem, use the calibration section of the **Diagnostics Utility** to make the appropriate adjustments.

The calibration procedure itself requires the use of a grid, and certified actual meters for voltage and current. The accuracy of the calibration will be directly affected by the accuracy of the measuring equipment you use. The **Diagnostics Utility** includes detailed instructions, and is available on the **Service Navigator CD** or at www.powerwavesoftware.com.

HOW TO USE TROUBLESHOOTING GUIDE

⚠ WARNING

Service and Repair should only be performed by Lincoln Electric Factory Trained Personnel. Unauthorized repairs performed on this equipment may result in danger to the technician and machine operator and will invalidate your factory warranty. For your safety and to avoid Electrical Shock, please observe all safety notes and precautions detailed throughout this manual.

This Troubleshooting Guide is provided to help you locate and repair possible machine malfunctions. Simply follow the three-step procedure listed below.

Step 1. LOCATE PROBLEM (SYMPTOM).

Look under the column labeled "PROBLEM (SYMPTOMS)". This column describes possible symptoms that the machine may exhibit. Find the listing that best describes the symptom that the machine is exhibiting.

Step 2. POSSIBLE CAUSE.

The second column labeled "POSSIBLE CAUSE" lists the obvious external possibilities that may contribute to the machine symptom.

Step 3. RECOMMENDED COURSE OF ACTION

This column provides a course of action for the Possible Cause, generally it states to contact your local Lincoln Authorized Field Service Facility.

If you do not understand or are unable to perform the Recommended Course of Action safely, contact your local Lincoln Authorized Field Service Facility.

⚠ WARNING



ELECTRIC SHOCK can kill.

- Turn the input power OFF at the welding power source before installation or changing drive rolls and/or guides.
- Do not touch electrically live parts.
- When inching with the gun trigger, electrode and drive mechanism are "hot" to work and ground and could remain energized several seconds after the gun trigger is released.
- Welding power source must be connected to system ground per the National Electrical Code or any applicable local codes.
- Only qualified personnel should perform maintenance work.

Observe all additional Safety Guidelines detailed throughout this manual.

⚠ CAUTION

If for any reason you do not understand the test procedures or are unable to perform the tests/repairs safely, contact your **Local Lincoln Authorized Field Service Facility** for technical troubleshooting assistance before you proceed.

POWER WAVE® C300 CE



USING THE STATUS LED TO TROUBLESHOOT SYSTEM PROBLEMS

Not all of the **Power Wave C300 CE** errors will be displayed on the user interface. There are three status lights that contain error sequences that may not show up on the user interface. If a problem occurs it is important to note the condition of the status lights. **Therefore, prior to cycling power to the system, check the power source status light for error sequences as noted below.**

There are two status lights located above the wire drive in the wire feeder compartment. One of the status lights is for the main control board (labeled "status", and one for the wire drive module. The third status light is internal and is located on the input control board.

There is an audible beeper associated with this input control board's status light. So the error codes on the input board can be detected through either the status light or the status beeper.

Included in this section is information about the Status Lights and some basic troubleshooting charts for both machine and weld performance.

The status lights on the main control board and the wire drive module are dual-color LED's. Normal operation for each is steady green. Where as the status light on the input control board is one color. Normal operation is for the status light to be off (and the buzzer to be off).

Error conditions are indicated in the following Table E.1.

TABLE E.1

Light Condition	Meaning	
	Main control board status light and Wiredrive Status Light	Input control board
Steady Green	System OK. Power source is operational, and is communicating normally with all healthy peripheral equipment connected to its ArcLink network.	Not applicable.
Blinking Green	Occurs during power up or a system reset, and indicates the POWER WAVE® C300 CE is mapping (identifying) each component in the system. Normal for first 1-10 seconds after power is turned on, or if the system configuration is changed during operation.	Not applicable.
Fast Blinking Green	Indicates Auto-mapping has failed	Not applicable.
Alternating Green and Red	Non-recoverable system fault. If the Status lights are flashing any combination of red and green, errors are present. Read the error code(s) before the machine is turned off.	Not applicable.
	Error Code interpretation through the Status light is detailed in the Service Manual. Individual code digits are flashed in red with a long pause between digits. If more than one code is present, the codes will be separated by a green light. Only active error conditions will be accessible through the Status Light.	
	Error codes can also be retrieved with the Diagnostics Utility (included on the Service Navigator CD or available at www.power-wavesoftware.com). This is the preferred method, since it can access historical information contained in the error logs.	
	To clear the active error(s), turn power source off, and back on to reset.	
Steady Red	Not applicable.	Not applicable.
Blinking Red	Not applicable.	Error Code interpretation - Individual code digits are flashed in red with a long pause between digits. These error codes are three digit codes that all start with a number three.
Status LED off	Not applicable.	System OK

CAUTION

If for any reason you do not understand the test procedures or are unable to perform the tests/repairs safely, contact your **Local Lincoln Authorized Field Service Facility** for technical troubleshooting assistance before you proceed.

POWER WAVE® C300 CE



Observe all Safety Guidelines detailed throughout this manual

ERROR CODES FOR THE POWER WAVE®

The following is a partial list of possible error codes for the POWER WAVE® C300 CE. For a complete listing consult the Service Manual for this machine.

MAIN CONTROL BOARD ("STATUS" LIGHT)	
Error Code #	Indication
36 Thermal error	Indicates over temperature. Usually accompanied by Thermal LED. Check fan operation. Be sure process does not exceed duty cycle limit of the machine
54 Secondary (Output) over current error	The long term average secondary (weld) current limit has been exceeded. NOTE: The long term average secondary current limit is 325 amps.
56 Chopper communication error	Indicates communication link between main control board and chopper has errors. If cycling the input power on the machine does not clear the error, contact the Service Department.
58 Primary Fault error	Review error code from input board status light or status beeper. Most likely caused by an over power condition which caused an under voltage on the primary bus. If cycling the input power on the machine does not clear the error, contact the Service Department.
Other	Error codes that contain three or four digits are defined as fatal errors. These codes generally indicate internal errors on the Power Source Control Board. If cycling the input power on the machine does not clear the error, contact the Service Department.
WIRE DRIVE MODULE	
81 Motor Overload	Long term average motor current limit has been exceeded. Typically indicates mechanical overload of system. If problem continues consider higher torque gear ratio (lower speed range).
82 Motor Overcurrent	Absolute maximum motor current level has been exceeded. This is a short term average to protect drive circuitry.

CAUTION

If for any reason you do not understand the test procedures or are unable to perform the tests/repairs safely, contact your **Local Lincoln Authorized Field Service Facility** for technical troubleshooting assistance before you proceed.

POWER WAVE® C300 CE



Observe all Safety Guidelines detailed throughout this manual

INPUT CONTROL BOARD	
Error Code #	Indication
331 Peak input current limit	Input current limit has been exceeded. Typically indicates short term power overload. If problem persists contact Service Department.
333 Under-voltage lockout	+15 VDC supply on Input control board too low. Verify input voltage is within the acceptable range. If problem persists contact service department.
336 Thermal Fault	Thermostat on primary module tripped. Typically caused by bottom fan not working.
337 Pre-charge timeout	Problem with start-up sequence. If problem persists contact Service Department.
346 Transformer primary over current	Transformer current too high. Typically indicates short term power overload. If problem persists contact service department.
Other	Contact the Service Department.

⚠ CAUTION

If for any reason you do not understand the test procedures or are unable to perform the tests/repairs safely, contact your **Local Lincoln Authorized Field Service Facility** for technical troubleshooting assistance before you proceed.

POWER WAVE® C300 CE



Observe all Safety Guidelines detailed throughout this manual

PROBLEMS (SYMPTOMS)	POSSIBLE CAUSE	RECOMMENDED COURSE OF ACTION
Basic Machine Problems		
Input fuses keep blowing	1. Improperly sized input fuses.	1. Make sure fuses are properly sized. See installation section of this manual for recommended sizes.
	2. Improper Weld Procedure requiring output levels in excess of machine rating.	2. Reduce output current, duty cycle, or both.
	3. Major physical or electrical damage is evident when the covers are removed.	3. Contact your local authorized Lincoln Electric Field Service facility for technical assistance.
Machine will not power up (no lights)	1. No Input Power	1. Make sure input supply disconnect has been turned ON. Check input fuses. Make certain that the Power Switch (SW1) on the power source is in the "ON" position.
	2. Input voltage is too low or too high.	2. Make certain that input voltage is correct, according to the Rating Plate located on the rear of the machine.
Machine won't weld, can't get any output. This problem will normally be accompanied by an error code. See "Status Light" section of this document for additional information.	1. Input voltage is too low or too high.	1. Make certain that input voltage is correct, according to the Rating Plate located on the rear of the machine.
	2. Thermal Error.	2. See "Thermal LED is ON" section.
	3. Secondary current limit has been exceeded. (see error 54)	3. Possible short in output circuit. If condition persists, contact an authorized Lincoln Electric Field Service facility.
	3a. Input control board fault (see input control board error status).	

⚠ CAUTION

If for any reason you do not understand the test procedures or are unable to perform the tests/repairs safely, contact your **Local Lincoln Authorized Field Service Facility** for technical troubleshooting assistance before you proceed.

POWER WAVE® C300 CE



Observe all Safety Guidelines detailed throughout this manual

PROBLEMS (SYMPTOMS)	POSSIBLE CAUSE	RECOMMENDED COURSE OF ACTION
Basic Machine Problems (Continued)		
Thermal LED is ON	1. Improper fan operation.	1. Check for proper fan operation. Fan should run in a low speed setting when the machine is idle and in a high speed when the output is triggered. Check for material blocking intake or exhaust louvers, or for excessive dirt clogging cooling channels in machine.
	2. Open thermostat circuit.	2. Check for broken wires, open connections or faulty thermostats in the thermostat circuit.
“Real Time Clock” no longer functioning	1. Control PC Board Battery.	1. Replace the battery (Type: BS2032)
Weld and Arc Quality Problems		
General degradation of weld performance	1. Wire feed problem.	1. Check for feeding problems. Make sure proper gear ratio has been selected.
	2. Cabling problems.	2. Check for bad connections, excessive loops in cable, etc. NOTE: The presence of heat in the external welding circuit indicates poor connections or undersized cables.
	3. Loss of, or improper Shielding Gas.	3. Verify gas flow and type are correct.
	4. Verify weld mode is correct for process.	4. Select the correct weld mode for the application.
	5. Machine calibration.	5. The power source may require calibration. (current, voltage, WFS).
	6. Wire feed problem.	6. Check for feeding problems. Make sure proper gear ratio has been selected.

⚠ CAUTION

If for any reason you do not understand the test procedures or are unable to perform the tests/repairs safely, contact your **Local Lincoln Authorized Field Service Facility** for technical troubleshooting assistance before you proceed.

POWER WAVE® C300 CE



Observe all Safety Guidelines detailed throughout this manual

PROBLEMS (SYMPTOMS)	POSSIBLE CAUSE	RECOMMENDED COURSE OF ACTION
Weld and Arc Quality Problems (Continued)		
Wire burns back to tip at the end of the weld.	1. Burnback Time	1. Reduce burnback time and/or work point.
Machine output shuts down during a weld.	1. Secondary current limit has been exceeded, and the machine shuts down to protect itself.	1. Adjust procedure or reduce load to lower current draw from the machine.
	2. System Fault	2. A non-recoverable fault will interrupt welding. This condition will also result in a status light blinking. See the Status Light section for more information.
Machine won't produce full output.	1. Input voltage may be too low, limiting output capability of the power source.	1. Make certain that the input voltage is proper, according to the Rating Plate located on the rear of the machine.
	2. Machine calibration.	2. Calibrate secondary current and voltage.
Excessively long and erratic arc.	1. Wire feed problem.	1. Check for feeding problems. Make sure proper gear ratio has been selected.
	2. Loss of, or improper Shielding Gas	2. Verify gas flow and type are correct
	3. Machine calibration.	3. Calibrate secondary current and voltage.

⚠ CAUTION

If for any reason you do not understand the test procedures or are unable to perform the tests/repairs safely, contact your **Local Lincoln Authorized Field Service Facility** for technical troubleshooting assistance before you proceed.

POWER WAVE® C300 CE



Observe all Safety Guidelines detailed throughout this manual

PROBLEMS (SYMPTOMS)	POSSIBLE CAUSE	RECOMMENDED COURSE OF ACTION
Ethernet		
Cannot Connect	1. Physical connection.	1. Verify that the correct patch cable or cross over cable is being used (refer to local IT department for assistance). 1a. Verify the cables are fully inserted into the bulk head connector. 1b. The LED under the PC board ethernet connector will be lit when the machine is connected to another network device.
	2. IP address information.	2. Use the appropriate PC utility to verify the correct IP address information has been entered. 2a. Verify no duplicate the IP addresses exist on the network.
	3. Ethernet Speed	3. Verify that the network device connected to the Power Wave is either a 10-baseT device or a 10/100-baseT device.
Connection Drops while welding	1. Cable Location	1. Verify Network cable is not located next to current carrying conductors. This would include input power cables and welding output cables.

⚠ CAUTION

If for any reason you do not understand the test procedures or are unable to perform the tests/repairs safely, contact your **Local Lincoln Authorized Field Service Facility** for technical troubleshooting assistance before you proceed.

POWER WAVE® C300 CE



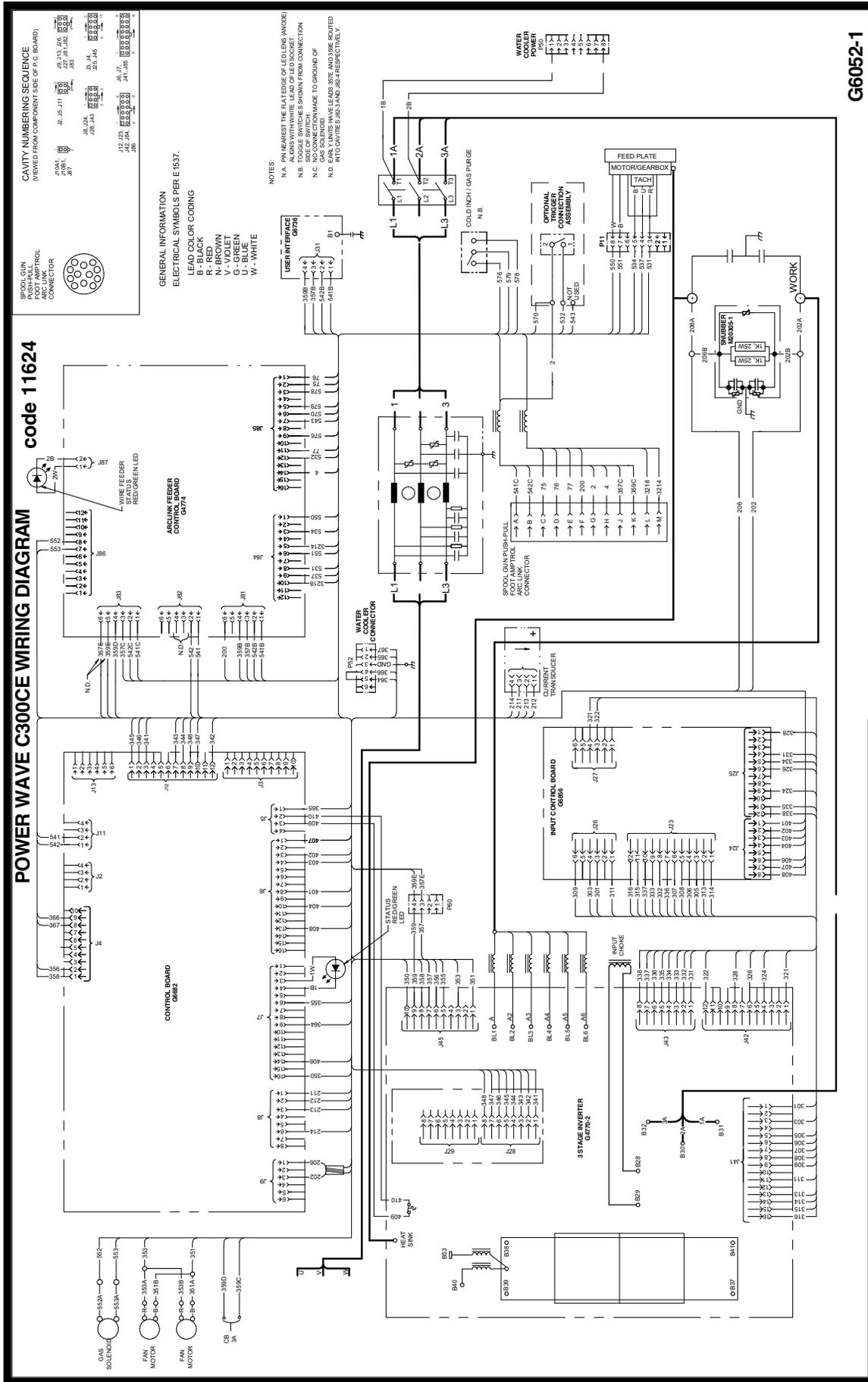

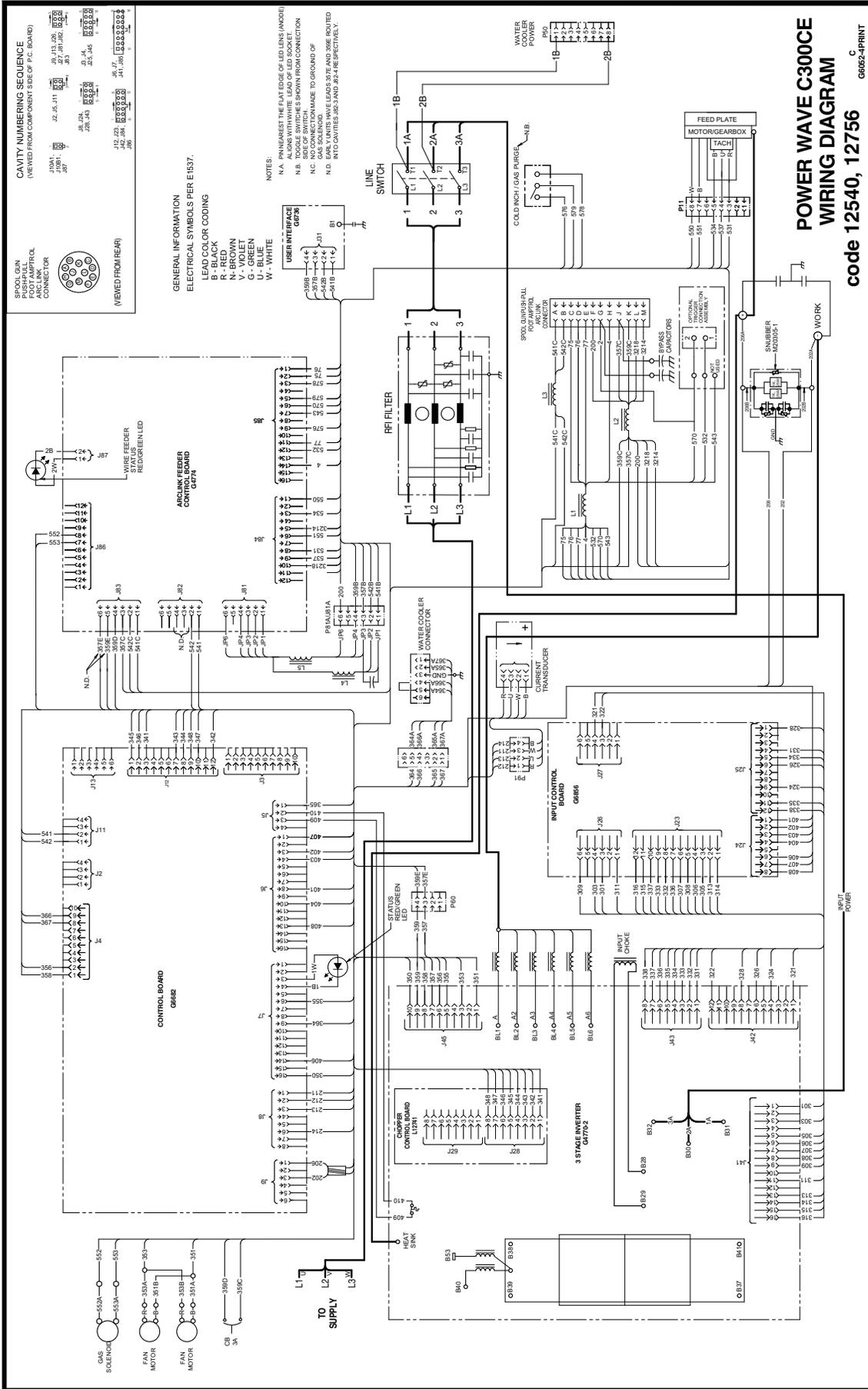

NOTE: This diagram is for reference only. It may not be accurate for all machines covered by this manual. The specific diagram for a particular code is pasted inside the machine on one of the enclosure panels. If the diagram is illegible, write to the Service Department for a replacement. Give the equipment code number.

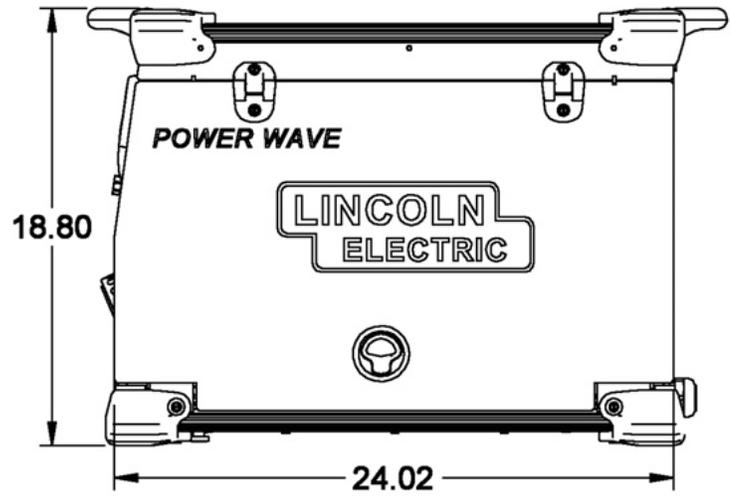
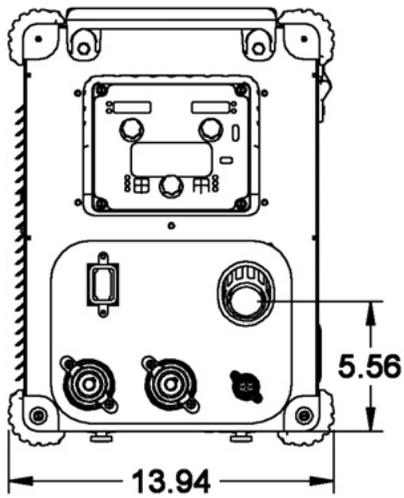
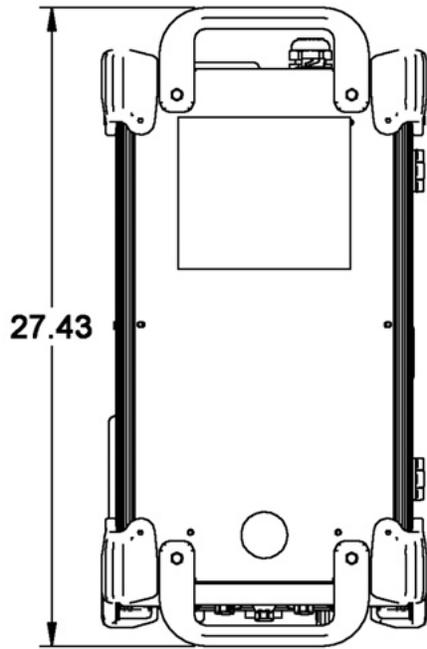

NOTES

POWER WAVE® C300 CE



			
WARNING	<ul style="list-style-type: none"> Do not touch electrically live parts or electrode with skin or wet clothing. Insulate yourself from work and ground. 	<ul style="list-style-type: none"> Keep flammable materials away. 	<ul style="list-style-type: none"> Wear eye, ear and body protection.
Spanish AVISO DE PRECAUCION	<ul style="list-style-type: none"> No toque las partes o los electrodos bajo carga con la piel o ropa mojada. Aíslese del trabajo y de la tierra. 	<ul style="list-style-type: none"> Mantenga el material combustible fuera del área de trabajo. 	<ul style="list-style-type: none"> Protéjase los ojos, los oídos y el cuerpo.
French ATTENTION	<ul style="list-style-type: none"> Ne laissez ni la peau ni des vêtements mouillés entrer en contact avec des pièces sous tension. Isolez-vous du travail et de la terre. 	<ul style="list-style-type: none"> Gardez à l'écart de tout matériel inflammable. 	<ul style="list-style-type: none"> Protégez vos yeux, vos oreilles et votre corps.
German WARNUNG	<ul style="list-style-type: none"> Berühren Sie keine stromführenden Teile oder Elektroden mit Ihrem Körper oder feuchter Kleidung! Isolieren Sie sich von den Elektroden und dem Erdboden! 	<ul style="list-style-type: none"> Entfernen Sie brennbares Material! 	<ul style="list-style-type: none"> Tragen Sie Augen-, Ohren- und Körperschutz!
Portuguese ATENÇÃO	<ul style="list-style-type: none"> Não toque partes elétricas e electrodos com a pele ou roupa molhada. Isole-se da peça e terra. 	<ul style="list-style-type: none"> Mantenha inflamáveis bem guardados. 	<ul style="list-style-type: none"> Use proteção para a vista, ouvido e corpo.
Japanese 注意事項	<ul style="list-style-type: none"> 通電中の電気部品、又は溶材にヒブやぬれた布で触れないこと。 施工物やアースから身体が絶縁されている様にして下さい。 	<ul style="list-style-type: none"> 燃えやすいものの側での溶接作業は絶対にしてはなりません。 	<ul style="list-style-type: none"> 目、耳及び身体に保護具をして下さい。
Chinese 警告	<ul style="list-style-type: none"> 皮肤或湿衣物切勿接触带电部件及焊条。 使你自已与地面和工件绝缘。 	<ul style="list-style-type: none"> 把一切易燃物品移离工作场所。 	<ul style="list-style-type: none"> 佩戴眼、耳及身体劳动保护用具。
Korean 위험	<ul style="list-style-type: none"> 전도체나 용접봉을 젖은 헝겍 또는 피부로 절대 접촉치 마십시오. 모재와 접지를 접촉치 마십시오. 	<ul style="list-style-type: none"> 인화성 물질을 접근시키지 마십시오. 	<ul style="list-style-type: none"> 눈, 귀와 몸에 보호장구를 착용하십시오.
Arabic تحذير	<ul style="list-style-type: none"> لا تلمس الاجزاء التي يسري فيها التيار الكهربائي أو الالكترود بجسدك أو بالملابس المبللة بالماء. ضع عازلا على جسمك خلال العمل. 	<ul style="list-style-type: none"> ضع المواد القابلة للاشتعال في مكان بعيد. 	<ul style="list-style-type: none"> ضع أدوات وملابس واقية على عينيك وأذنيك وجسمك.

READ AND UNDERSTAND THE MANUFACTURER'S INSTRUCTION FOR THIS EQUIPMENT AND THE CONSUMABLES TO BE USED AND FOLLOW YOUR EMPLOYER'S SAFETY PRACTICES.

SE RECOMIENDA LEER Y ENTENDER LAS INSTRUCCIONES DEL FABRICANTE PARA EL USO DE ESTE EQUIPO Y LOS CONSUMIBLES QUE VA A UTILIZAR, SIGA LAS MEDIDAS DE SEGURIDAD DE SU SUPERVISOR.

LISEZ ET COMPRENEZ LES INSTRUCTIONS DU FABRICANT EN CE QUI REGARDE CET EQUIPMENT ET LES PRODUITS A ETRE EMPLOYES ET SUIVEZ LES PROCEDURES DE SECURITE DE VOTRE EMPLOYEUR.

LESEN SIE UND BEFOLGEN SIE DIE BETRIEBSANLEITUNG DER ANLAGE UND DEN ELEKTRODENEINSATZ DES HERSTELLERS. DIE UNFALLVERHÜTUNGSVORSCHRIFTEN DES ARBEITGEBERS SIND EBENFALLS ZU BEACHTEN.

			
<ul style="list-style-type: none"> ● Keep your head out of fumes. ● Use ventilation or exhaust to remove fumes from breathing zone. 	<ul style="list-style-type: none"> ● Turn power off before servicing. 	<ul style="list-style-type: none"> ● Do not operate with panel open or guards off. 	WARNING
<ul style="list-style-type: none"> ● Los humos fuera de la zona de respiración. ● Mantenga la cabeza fuera de los humos. Utilice ventilación o aspiración para gases. 	<ul style="list-style-type: none"> ● Desconectar el cable de alimentación de poder de la máquina antes de iniciar cualquier servicio. 	<ul style="list-style-type: none"> ● No operar con panel abierto o guardas quitadas. 	Spanish AVISO DE PRECAUCION
<ul style="list-style-type: none"> ● Gardez la tête à l'écart des fumées. ● Utilisez un ventilateur ou un aspirateur pour ôter les fumées des zones de travail. 	<ul style="list-style-type: none"> ● Débranchez le courant avant l'entretien. 	<ul style="list-style-type: none"> ● N'opérez pas avec les panneaux ouverts ou avec les dispositifs de protection enlevés. 	French ATTENTION
<ul style="list-style-type: none"> ● Vermeiden Sie das Einatmen von Schweißrauch! ● Sorgen Sie für gute Be- und Entlüftung des Arbeitsplatzes! 	<ul style="list-style-type: none"> ● Strom vor Wartungsarbeiten abschalten! (Netzstrom völlig öffnen; Maschine anhalten!) 	<ul style="list-style-type: none"> ● Anlage nie ohne Schutzgehäuse oder Innenschutzverkleidung in Betrieb setzen! 	German WARNUNG
<ul style="list-style-type: none"> ● Mantenha seu rosto da fumaça. ● Use ventilação e exaustão para remover fumo da zona respiratória. 	<ul style="list-style-type: none"> ● Não opere com as tampas removidas. ● Desligue a corrente antes de fazer serviço. ● Não toque as partes elétricas nuas. 	<ul style="list-style-type: none"> ● Mantenha-se afastado das partes moventes. ● Não opere com os painéis abertos ou guardas removidas. 	Portuguese ATENÇÃO
<ul style="list-style-type: none"> ● ヒュームから頭を離すようにして下さい。 ● 換気や排煙に十分留意して下さい。 	<ul style="list-style-type: none"> ● メンテナンス・サービスに取りかかる際には、まず電源スイッチを必ず切して下さい。 	<ul style="list-style-type: none"> ● パネルやカバーを取り外したままで機械操作をしないで下さい。 	Japanese 注意事項
<ul style="list-style-type: none"> ● 頭部遠離煙霧。 ● 在呼吸區使用通風或排風器除煙。 	<ul style="list-style-type: none"> ● 維修前切斷電源。 	<ul style="list-style-type: none"> ● 儀表板打開或沒有安全罩時不準作業。 	Chinese 警告
<ul style="list-style-type: none"> ● 얼굴로부터 용접가스를 멀리하십시오. ● 호흡지역으로부터 용접가스를 제거하기 위해 가스제거기나 통풍기를 사용하십시오. 	<ul style="list-style-type: none"> ● 보수전에 전원을 차단하십시오. 	<ul style="list-style-type: none"> ● 판넬이 열린 상태로 작동치 마십시오. 	Korean 위험
<ul style="list-style-type: none"> ● ابعد رأسك بعيداً عن الدخان. ● استعمل التهوية أو جهاز ضغط الدخان للخارج لكي تبعد الدخان عن المنطقة التي تتنفس فيها. 	<ul style="list-style-type: none"> ● أقطع التيار الكهربائي قبل القيام بأية صيانة. 	<ul style="list-style-type: none"> ● لا تشغيل هذا الجهاز اذا كانت الاغطية الحديدية الواقية ليست عليه. 	Arabic تحذير

LEIA E COMPREENDA AS INSTRUÇÕES DO FABRICANTE PARA ESTE EQUIPAMENTO E AS PARTES DE USO, E SIGA AS PRÁTICAS DE SEGURANÇA DO EMPREGADOR.

使う機械や溶材のメーカーの指示書をよく読み、まず理解して下さい。そして貴社の安全規定に従って下さい。

請詳細閱讀並理解製造廠提供的說明以及應該使用的銀焊材料，並請遵守貴方的有關勞動保護規定。

이 제품에 동봉된 작업지침서를 숙지하시고 귀사의 작업자 안전수칙을 준수하시기 바랍니다.

اقرأ بتمعن وافهم تعليمات المصنع المنتج لهذه المعدات والمواد قبل استعمالها واتبع تعليمات الوقاية لصاحب العمل.

CUSTOMER ASSISTANCE POLICY

The business of The Lincoln Electric Company is manufacturing and selling high quality welding equipment, consumables, and cutting equipment. Our challenge is to meet the needs of our customers and to exceed their expectations. On occasion, purchasers may ask Lincoln Electric for advice or information about their use of our products. We respond to our customers based on the best information in our possession at that time. Lincoln Electric is not in a position to warrant or guarantee such advice, and assumes no liability, with respect to such information or advice. We expressly disclaim any warranty of any kind, including any warranty of fitness for any customer's particular purpose, with respect to such information or advice. As a matter of practical consideration, we also cannot assume any responsibility for updating or correcting any such information or advice once it has been given, nor does the provision of information or advice create, expand or alter any warranty with respect to the sale of our products.

Lincoln Electric is a responsive manufacturer, but the selection and use of specific products sold by Lincoln Electric is solely within the control of, and remains the sole responsibility of the customer. Many variables beyond the control of Lincoln Electric affect the results obtained in applying these types of fabrication methods and service requirements.

Subject to Change – This information is accurate to the best of our knowledge at the time of printing. Please refer to www.lincolnelectric.com for any updated information.



THE LINCOLN ELECTRIC COMPANY

22801 St. Clair Avenue • Cleveland, OH • 44117-1199 • U.S.A.
Phone: +1.216.481.8100 • www.lincolnelectric.com