

# SP WELDERS WIRING DIAGRAM M15732 REV: E

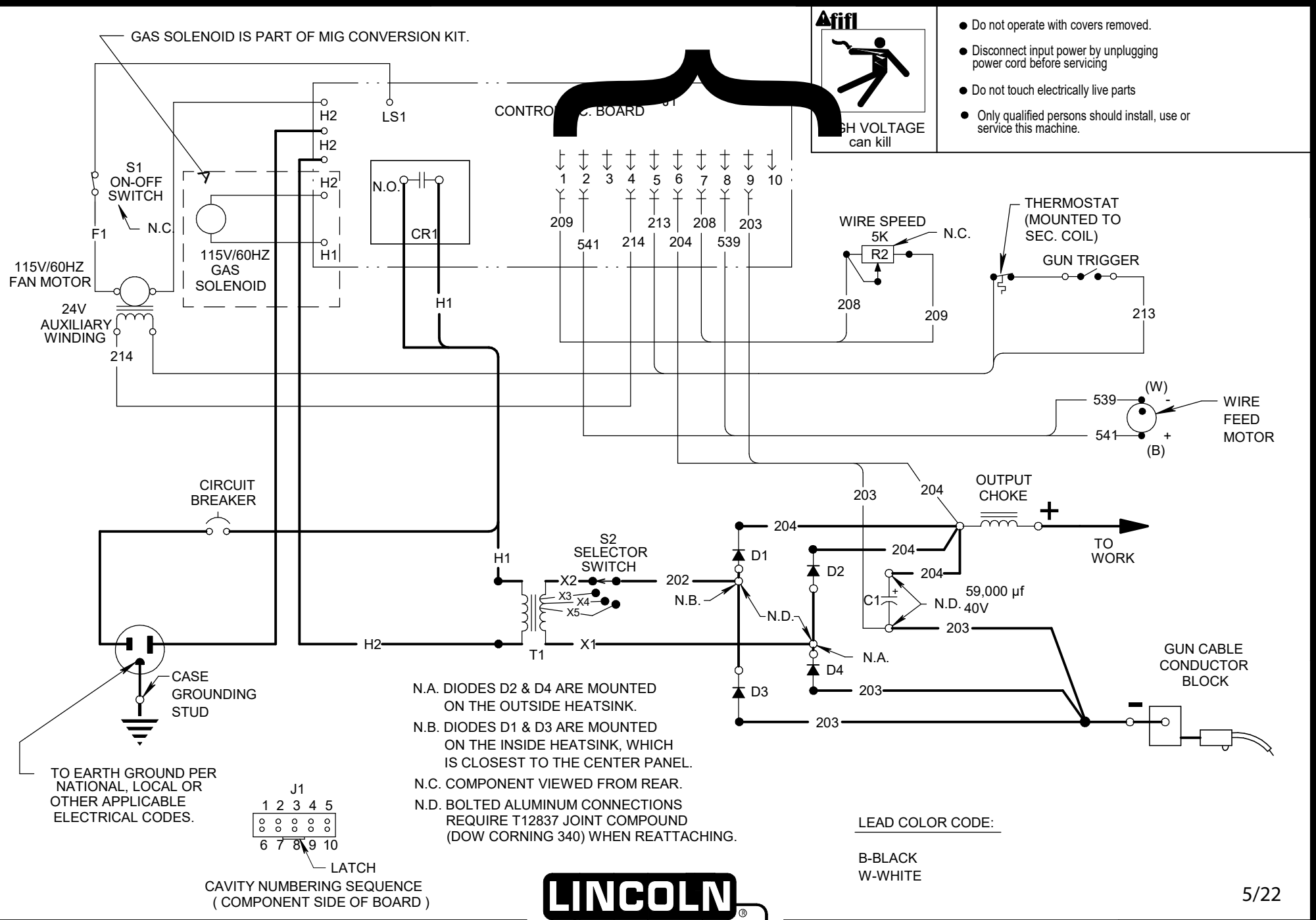

- Do not operate with covers removed.
- Disconnect input power by unplugging power cord before servicing
- Do not touch electrically live parts
- Only qualified persons should install, use or service this machine.



CLEVELAND, OHIO U.S.A.