



NOTE: This manual will cover most of the troubleshooting and repair procedures for the code numbers listed. Some variances may exist when troubleshooting/repairing later code numbers.

VANTAGE[®] 400

For use with machines having Code Numbers:

**11186, 11462, 11785, 11920, 12305,
12319, 11463, 11464, 12195, 11296,
12308, 11687, 11959, 12307, 11297,
11787, 11921, 12303, 11511, 11576,
11954, 11961, 12304, 12331, 12487,
12597, 12559**

SERVICE MANUAL

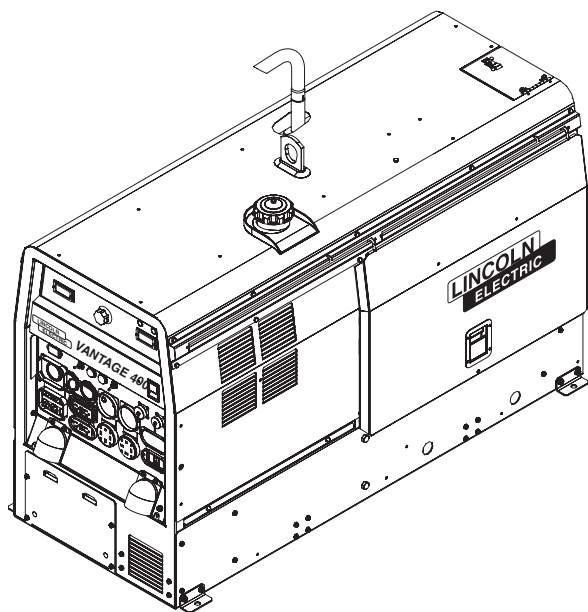

Need Help? Call 1.888.935.3877
to talk to a Service Representative

Hours of Operation:
8:00 AM to 6:00 PM (ET) Mon. thru Fri.

After hours?
Use "Ask the Experts" at lincolnelectric.com
A Lincoln Service Representative will contact you
no later than the following business day.

For Service outside the USA:
Email: globalservice@lincolnelectric.com

SAFETY DEPENDS ON YOU

Service and repair should be performed by only Lincoln Electric Factory Trained Personnel. Unauthorized repairs performed on this equipment may result in danger to the technician and machine operator and will invalidate your factory warranty. For your safety and to avoid Electrical Shock, please observe all safety notes and precautions detailed throughout this manual.

WARNING

This statement appears where the information must be followed exactly to avoid serious personal injury or loss of life.

CAUTION

This statement appears where the information must be followed to avoid minor personal injury or damage to this equipment.

KEEP YOUR HEAD OUT OF THE FUMES.

DON'T get too close to the arc. Use corrective lenses if necessary to stay a reasonable distance away from the arc.

READ and obey the Material Safety Data Sheet (MSDS) and the warning label that appears on all containers of welding materials.

USE ENOUGH VENTILATION or exhaust at the arc, or both, to keep the fumes and gases from your breathing zone and the general area.

IN A LARGE ROOM OR OUTDOORS, natural ventilation may be adequate if you keep your head out of the fumes (See below).

USE NATURAL DRAFTS or fans to keep the fumes away from your face.

If you develop unusual symptoms, see your supervisor. Perhaps the welding atmosphere and ventilation system should be checked.



WEAR CORRECT EYE, EAR & BODY PROTECTION

PROTECT your eyes and face with welding helmet properly fitted and with proper grade of filter plate (See ANSI Z49.1).



PROTECT your body from welding spatter and arc flash with protective clothing including woolen clothing, flame-proof apron and gloves, leather leggings, and high boots.

PROTECT others from splatter, flash, and glare with protective screens or barriers.

IN SOME AREAS, protection from noise may be appropriate.

BE SURE protective equipment is in good condition.

Also, wear safety glasses in work area AT ALL TIMES.



SPECIAL SITUATIONS

DO NOT WELD OR CUT containers or materials which previously had been in contact with hazardous substances unless they are properly cleaned. This is extremely dangerous.

DO NOT WELD OR CUT painted or plated parts unless special precautions with ventilation have been taken. They can release highly toxic fumes or gases.

Additional precautionary measures

PROTECT compressed gas cylinders from excessive heat, mechanical shocks, and arcs; fasten cylinders so they cannot fall.

BE SURE cylinders are never grounded or part of an electrical circuit.

REMOVE all potential fire hazards from welding area.

ALWAYS HAVE FIRE FIGHTING EQUIPMENT READY FOR IMMEDIATE USE AND KNOW HOW TO USE IT.





SECTION A: WARNINGS



CALIFORNIA PROPOSITION 65 WARNINGS

Diesel Engines

Diesel engine exhaust and some of its constituents are known to the State of California to cause cancer, birth defects, and other reproductive harm.

Gasoline Engines

The engine exhaust from this product contains chemicals known to the State of California to cause cancer, birth defects, or other reproductive harm.



ARC WELDING CAN BE HAZARDOUS. PROTECT YOURSELF AND OTHERS FROM POSSIBLE SERIOUS INJURY OR DEATH. KEEP CHILDREN AWAY. PACEMAKER WEARERS SHOULD CONSULT WITH THEIR DOCTOR BEFORE OPERATING.

Read and understand the following safety highlights. For additional safety information, it is strongly recommended that you purchase a copy of "Safety in Welding & Cutting - ANSI Standard Z49.1" from the American Welding Society, P.O. Box 351040, Miami, Florida 33135 or CSA Standard W117.2-1974. A Free copy of "Arc Welding Safety" booklet E205 is available from the Lincoln Electric Company, 22801 St. Clair Avenue, Cleveland, Ohio 44117-1199.

BE SURE THAT ALL INSTALLATION, OPERATION, MAINTENANCE AND REPAIR PROCEDURES ARE PERFORMED ONLY BY QUALIFIED INDIVIDUALS.



FOR ENGINE POWERED EQUIPMENT.

- 1.a. Turn the engine off before troubleshooting and maintenance work unless the maintenance work requires it to be running. 
- 1.b. Operate engines in open, well-ventilated areas or vent the engine exhaust fumes outdoors.
- 1.c. Do not add the fuel near an open flame welding arc or when the engine is running. Stop the engine and allow it to cool before refueling to prevent spilled fuel from vaporizing on contact with hot engine parts and igniting. Do not spill fuel when filling tank.  If fuel is spilled, wipe it up and do not start engine until fumes have been eliminated.

- 1.d. Keep all equipment safety guards, covers and devices in position and in good repair. Keep hands, hair, clothing and tools away from V-belts, gears, fans and all other moving parts when starting, operating or repairing equipment. 

- 1.e. In some cases it may be necessary to remove safety guards to perform required maintenance. Remove guards only when necessary and replace them when the maintenance requiring their removal is complete. Always use the greatest care when working near moving parts.

- 1.f. Do not put your hands near the engine fan. Do not attempt to override the governor or idler by pushing on the throttle control rods while the engine is running.

- 1.g. To prevent accidentally starting gasoline engines while turning the engine or welding generator during maintenance work, disconnect the spark plug wires, distributor cap or magneto wire as appropriate.

- 1.h. To avoid scalding, do not remove the radiator pressure cap when the engine is hot. 



ELECTRIC AND MAGNETIC FIELDS MAY BE DANGEROUS



- 2.a. Electric current flowing through any conductor causes localized Electric and Magnetic Fields (EMF). Welding current creates EMF fields around welding cables and welding machines
- 2.b. EMF fields may interfere with some pacemakers, and welders having a pacemaker should consult their physician before welding.
- 2.c. Exposure to EMF fields in welding may have other health effects which are now not known.
- 2.d. All welders should use the following procedures in order to minimize exposure to EMF fields from the welding circuit:
 - 2.d.1. Route the electrode and work cables together - Secure them with tape when possible.
 - 2.d.2. Never coil the electrode lead around your body.
 - 2.d.3. Do not place your body between the electrode and work cables. If the electrode cable is on your right side, the work cable should also be on your right side.
 - 2.d.4. Connect the work cable to the workpiece as close as possible to the area being welded.
 - 2.d.5. Do not work next to welding power source.



ELECTRIC SHOCK CAN KILL.



- 3.a. The electrode and work (or ground) circuits are electrically “hot” when the welder is on. Do not touch these “hot” parts with your bare skin or wet clothing. Wear dry, hole-free gloves to insulate hands.
- 3.b. Insulate yourself from work and ground using dry insulation. Make certain the insulation is large enough to cover your full area of physical contact with work and ground.

In addition to the normal safety precautions, if welding must be performed under electrically hazardous conditions (in damp locations or while wearing wet clothing; on metal structures such as floors, gratings or scaffolds; when in cramped positions such as sitting, kneeling or lying, if there is a high risk of unavoidable or accidental contact with the workpiece or ground) use the following equipment:

- Semiautomatic DC Constant Voltage (Wire) Welder.
 - DC Manual (Stick) Welder.
 - AC Welder with Reduced Voltage Control.
- 3.c. In semiautomatic or automatic wire welding, the electrode, electrode reel, welding head, nozzle or semiautomatic welding gun are also electrically “hot”.
 - 3.d. Always be sure the work cable makes a good electrical connection with the metal being welded. The connection should be as close as possible to the area being welded.
 - 3.e. Ground the work or metal to be welded to a good electrical (earth) ground.
 - 3.f. Maintain the electrode holder, work clamp, welding cable and welding machine in good, safe operating condition. Replace damaged insulation.
 - 3.g. Never dip the electrode in water for cooling.
 - 3.h. Never simultaneously touch electrically “hot” parts of electrode holders connected to two welders because voltage between the two can be the total of the open circuit voltage of both welders.
 - 3.i. When working above floor level, use a safety belt to protect yourself from a fall should you get a shock.
 - 3.j. Also see Items 6.c. and 8.



ARC RAYS CAN BURN.



- 4.a. Use a shield with the proper filter and cover plates to protect your eyes from sparks and the rays of the arc when welding or observing open arc welding. Headshield and filter lens should conform to ANSI Z87.1 standards.
- 4.b. Use suitable clothing made from durable flame-resistant material to protect your skin and that of your helpers from the arc rays.
- 4.c. Protect other nearby personnel with suitable, non-flammable screening and/or warn them not to watch the arc nor expose themselves to the arc rays or to hot spatter or metal.



FUMES AND GASES CAN BE DANGEROUS.



- 5.a. Welding may produce fumes and gases hazardous to health. Avoid breathing these fumes and gases. When welding, keep your head out of the fume. Use enough ventilation and/or exhaust at the arc to keep fumes and gases away from the breathing zone. **When welding with electrodes which require special ventilation such as stainless or hard facing (see instructions on container or MSDS) or on lead or cadmium plated steel and other metals or coatings which produce highly toxic fumes, keep exposure as low as possible and within applicable OSHA PEL and ACGIH TLV limits using local exhaust or mechanical ventilation. In confined spaces or in some circumstances, outdoors, a respirator may be required. Additional precautions are also required when welding on galvanized steel.**
- 5.b. The operation of welding fume control equipment is affected by various factors including proper use and positioning of the equipment, maintenance of the equipment and the specific welding procedure and application involved. Worker exposure level should be checked upon installation and periodically thereafter to be certain it is within applicable OSHA PEL and ACGIH TLV limits.
- 5.c. Do not weld in locations near chlorinated hydrocarbon vapors coming from degreasing, cleaning or spraying operations. The heat and rays of the arc can react with solvent vapors to form phosgene, a highly toxic gas, and other irritating products.
- 5.d. Shielding gases used for arc welding can displace air and cause injury or death. Always use enough ventilation, especially in confined areas, to insure breathing air is safe.
- 5.e. Read and understand the manufacturer’s instructions for this equipment and the consumables to be used, including the material safety data sheet (MSDS) and follow your employer’s safety practices. MSDS forms are available from your welding distributor or from the manufacturer.
- 5.f. Also see item 1.b.



WELDING AND CUTTING SPARKS CAN CAUSE FIRE OR EXPLOSION.



- 6.a. Remove fire hazards from the welding area. If this is not possible, cover them to prevent the welding sparks from starting a fire. Remember that welding sparks and hot materials from welding can easily go through small cracks and openings to adjacent areas. Avoid welding near hydraulic lines. Have a fire extinguisher readily available.
- 6.b. Where compressed gases are to be used at the job site, special precautions should be used to prevent hazardous situations. Refer to "Safety in Welding and Cutting" (ANSI Standard Z49.1) and the operating information for the equipment being used.
- 6.c. When not welding, make certain no part of the electrode circuit is touching the work or ground. Accidental contact can cause overheating and create a fire hazard.
- 6.d. Do not heat, cut or weld tanks, drums or containers until the proper steps have been taken to insure that such procedures will not cause flammable or toxic vapors from substances inside. They can cause an explosion even though they have been "cleaned". For information, purchase "Recommended Safe Practices for the Preparation for Welding and Cutting of Containers and Piping That Have Held Hazardous Substances", AWS F4.1 from the American Welding Society (see address above).
- 6.e. Vent hollow castings or containers before heating, cutting or welding. They may explode.
- 6.f. Sparks and spatter are thrown from the welding arc. Wear oil free protective garments such as leather gloves, heavy shirt, cuffless trousers, high shoes and a cap over your hair. Wear ear plugs when welding out of position or in confined places. Always wear safety glasses with side shields when in a welding area.
- 6.g. Connect the work cable to the work as close to the welding area as practical. Work cables connected to the building framework or other locations away from the welding area increase the possibility of the welding current passing through lifting chains, crane cables or other alternate circuits. This can create fire hazards or overheat lifting chains or cables until they fail.
- 6.h. Also see item 1.c.
- 6.i. Read and follow NFPA 51B "Standard for Fire Prevention During Welding, Cutting and Other Hot Work", available from NFPA, 1 Batterymarch Park, PO box 9101, Quincy, Ma 022690-9101.
- 6.j. Do not use a welding power source for pipe thawing.



CYLINDER MAY EXPLODE IF DAMAGED.

- 7.a. Use only compressed gas cylinders containing the correct shielding gas for the process used and properly operating regulators designed for the gas and pressure used. All hoses, fittings, etc. should be suitable for the application and maintained in good condition. 
- 7.b. Always keep cylinders in an upright position securely chained to an undercarriage or fixed support.
- 7.c. Cylinders should be located:
 - Away from areas where they may be struck or subjected to physical damage.
 - A safe distance from arc welding or cutting operations and any other source of heat, sparks, or flame.
- 7.d. Never allow the electrode, electrode holder or any other electrically "hot" parts to touch a cylinder.
- 7.e. Keep your head and face away from the cylinder valve outlet when opening the cylinder valve.
- 7.f. Valve protection caps should always be in place and hand tight except when the cylinder is in use or connected for use.
- 7.g. Read and follow the instructions on compressed gas cylinders, associated equipment, and CGA publication P-1, "Precautions for Safe Handling of Compressed Gases in Cylinders," available from the Compressed Gas Association 1235 Jefferson Davis Highway, Arlington, VA 22202.



FOR ELECTRICALLY POWERED EQUIPMENT.



- 8.a. Turn off input power using the disconnect switch at the fuse box before working on the equipment.
- 8.b. Install equipment in accordance with the U.S. National Electrical Code, all local codes and the manufacturer's recommendations.
- 8.c. Ground the equipment in accordance with the U.S. National Electrical Code and the manufacturer's recommendations.

Refer to <http://www.lincolnelectric.com/safety> for additional safety information.



Welding Safety
Interactive Web Guide
for mobile devices

Get the free mobile app at
<http://gettag.mobi>

ELECTROMAGNETIC COMPATABILITY (EMC)

CONFORMANCE

Products displaying the CE mark are in conformity with European Community Council Directive of 3 May 1989 on the approximation of the laws of the Member States relating to electromagnetic compatibility (89/336/EEC). It was manufactured in conformity with a national standard that implements a harmonized standard: EN 60974-10 Electromagnetic Compatibility (EMC) Product Standard for Arc Welding Equipment. It is for use with other Lincoln Electric equipment. It is designed for industrial and professional use.

INTRODUCTION

All electrical equipment generates small amounts of electromagnetic emission. Electrical emission may be transmitted through power lines or radiated through space, similar to a radio transmitter. When emissions are received by other equipment, electrical interference may result. Electrical emissions may affect many kinds of electrical equipment; other nearby welding equipment, radio and TV reception, numerical controlled machines, telephone systems, computers, etc. Be aware that interference may result and extra precautions may be required when a welding power source is used in a domestic establishment.

INSTALLATION AND USE

The user is responsible for installing and using the welding equipment according to the manufacturer's instructions. If electromagnetic disturbances are detected then it shall be the responsibility of the user of the welding equipment to resolve the situation with the technical assistance of the manufacturer. In some cases this remedial action may be as simple as earthing (grounding) the welding circuit, see Note. In other cases it could involve construction of an electromagnetic screen enclosing the power source and the work complete with associated input filters. In all cases electromagnetic disturbances must be reduced to the point where they are no longer troublesome.

Note: The welding circuit may or may not be earthed for safety reasons according to national codes. Changing the earthing arrangements should only be authorized by a person who is competent to assess whether the changes will increase the risk of injury, e.g., by allowing parallel welding current return paths which may damage the earth circuits of other equipment.

ASSESSMENT OF AREA

Before installing welding equipment the user shall make an assessment of potential electromagnetic problems in the surrounding area. The following shall be taken into account:

- a. other supply cables, control cables, signaling and telephone cables; above, below and adjacent to the welding equipment;
- b. radio and television transmitters and receivers;
- c. computer and other control equipment;
- d. safety critical equipment, e.g., guarding of industrial equipment;
- e. the health of the people around, e.g., the use of pacemakers and hearing aids;
- f. equipment used for calibration or measurement
- g. the immunity of other equipment in the environment. The user shall ensure that other equipment being used in the environment is compatible. This may require additional protection measures;
- h. the time of day that welding or other activities are to be carried out.

The size of the surrounding area to be considered will depend on the structure of the building and other activities that are taking place. The surrounding area may extend beyond the boundaries of the premises.

METHODS OF REDUCING EMISSIONS

Mains Supply

Welding equipment should be connected to the mains supply according to the manufacturer's recommendations. If interference occurs, it may be necessary to take additional precautions such as filtering of the mains supply. Consideration should be given to shielding the supply cable of permanently installed welding equipment, in metallic conduit or equivalent. Shielding should be electrically continuous throughout its length. The shielding should be connected to the welding power source so that good electrical contact is maintained between the conduit and the welding power source enclosure.

Maintenance of the Welding Equipment

The welding equipment should be routinely maintained according to the manufacturer's recommendations. All access and service doors and covers should be closed and properly fastened when the welding equipment is in operation. The welding equipment should not be modified in any way except for those changes and adjustments covered in the manufacturer's instructions. In particular, the spark gaps of arc striking and stabilizing devices should be adjusted and maintained according to the manufacturer's recommendations.

Welding Cables

The welding cables should be kept as short as possible and should be positioned close together, running at or close to floor level.

Equipotential Bonding

Bonding of all metallic components in the welding installation and adjacent to it should be considered. However, metallic components bonded to the work piece will increase the risk that the operator could receive a shock by touching these metallic components and the electrode at the same time. The operator should be insulated from all such bonded metallic components.

Earthing of the Workpiece

Where the workpiece is not bonded to earth for electrical safety, not connected to earth because of its size and position, e.g., ships hull or building steelwork, a connection bonding the workpiece to earth may reduce emissions in some, but not all instances. Care should be taken to prevent the earthing of the work piece increasing the risk of injury to users, or damage to other electrical equipment. Where necessary, the connection of the workpiece to earth should be made by a direct connection to the work piece, but in some countries where direct connection is not permitted, the bonding should be achieved by suitable capacitance, selected according to national regulations.

Screening and Shielding

Selective screening and shielding of other cables and equipment in the surrounding area may alleviate problems of interference. Screening of the entire welding installation may be considered for special applications.

¹ Portions of the preceding text are contained in EN 60974-10: "Electromagnetic Compatibility (EMC) product standard for arc welding equipment."

As a rule of thumb, for many mild steel electrode, if the air is visibly clear and you are comfortable, then the ventilation is generally adequate for your work. The most accurate way to determine if the worker exposure does not exceed the applicable exposure limit for compounds in the fumes and gases is to have an industrial hygienist take and analyze a sample of the air you are breathing. This is particularly important if you are welding with stainless, hardfacing or Special Ventilation products. All Lincoln MSDS have a maximum fume guideline number. If exposure to total fume is kept below that number, exposure to all fume from the electrode (not coatings or plating on the work) will be below the TLV.

There are steps that you can take to identify hazardous substances in your welding environment. Read the product label and material safety data sheet for the electrode posted in the work place or in the electrode or flux container to see what fumes can be reasonably expected from use of the product and to determine if special ventilation is needed. Secondly, know what the base metal is and determine if there is any paint, plating, or coating that could expose you to toxic fumes and/or gases. Remove it from the metal being welded, if possible. If you start to feel uncomfortable, dizzy or nauseous, there is a possibility that you are being overexposed to fumes and gases, or suffering from oxygen deficiency. Stop welding and get some fresh air immediately. Notify your supervisor and co-workers so the situation can be corrected and other workers can avoid the hazard. Be sure you are following these safe practices, the consumable labeling and MSDS to improve the ventilation in your area. Do not continue welding until the situation has been corrected.

NOTE: The MSDS for all Lincoln consumables is available on Lincoln's website: www.lincolnelectric.com

Before we turn to the methods available to control welding fume exposure, you should understand a few basic terms:

Natural Ventilation is the movement of air through the workplace caused by natural forces. Outside, this is usually the wind. Inside, this may be the flow of air through open windows and doors.

Mechanical Ventilation is the movement of air through the workplace caused by an electrical device such as a portable fan or permanently mounted fan in the ceiling or wall.

Source Extraction (Local Exhaust) is a mechanical device used to capture welding fume at or near the arc and filter contaminants out of the air.

The ventilation or exhaust needed for your application depends upon many factors such as:

- Workspace volume
- Workspace configuration
- Number of welders
- Welding process and current
- Consumables used (mild steel, hardfacing, stainless, etc.)
- Allowable levels (TLV, PEL, etc.)
- Material welded (including paint or plating)
- Natural airflow

Your work area has adequate ventilation when there is enough ventilation and/or exhaust to control worker exposure to hazardous materials in the welding fumes and gases so the applicable limits for those materials is not exceeded. See chart of TLV and PEL for Typical Electrode Ingredients, the OSHA PEL (Permissible Exposure Limit), and the recommended guideline, the ACGIH TLV (Threshold Limit Value), for many compounds found in welding fume.

Ventilation

There are many methods which can be selected by the user to provide adequate ventilation for the specific application. The following section provides general information which may be helpful in evaluating what type of ventilation equipment may be suitable for your application. When ventilation equipment is installed, you should confirm worker exposure is controlled within applicable OSHA PEL and/or ACGIH TLV. According to OSHA regulations, when welding and cutting (mild steels), natural ventilation is usually considered sufficient to meet requirements, provided that:

1. The room or welding area contains at least 10,000 cubic feet (about 22' x 22' x 22') for each welder.
2. The ceiling height is not less than 16 feet.
3. Cross ventilation is not blocked by partitions, equipment, or other structural barriers.
4. Welding is not done in a coned space.

Spaces that do not meet these requirements should be equipped with mechanical ventilating equipment that exhausts at least 2000 CFM of air for each welder, except where local exhaust hoods or booths, or air-line respirators are used.

Important Safety Note:

When welding with electrodes which require special ventilation such as stainless or hardfacing (see instructions on container or MSDS) or on lead or cadmium plated steel and other metals or coatings which produce hazardous fumes, keep exposure as low as possible and below exposure limit values (PEL and TLV) for materials in the fume using local exhaust or mechanical ventilation. In coned spaces or in some circumstances, for example outdoors, a respirator may be required if exposure cannot be controlled to the PEL or TLV. (See MSDS and chart of TLV and PEL for Typical Electrode Ingredients.) Additional precautions are also required when welding on galvanized steel.

BIBLIOGRAPHY AND SUGGESTED READING

ANSI Z87.1, Practice for Occupational and Educational Eye and Face Protection, American National Standards Institute, 11 West 42nd Street, New York, NY 10036.

Arc Welding and Your Health: A Handbook of Health Information for Welding. Published by The American Industrial Hygiene Association, 2700 Prosperity Avenue, Suite 250, Fairfax, VA 22031-4319.

NFPA Standard 51B, Cutting and Welding Processes, National Fire Protection Association, 1 Batterymarch Park, P.O. Box 9146, Quincy, MA 02269-9959.

OSHA General Industry Standard 29 CFR 1910 Subpart Q. OSHA Hazard Communication Standard 29 CFR 1910.1200. Available from the Occupational Safety and Health Administration at <http://www.osha.org> or contact your local OSHA office.

The following publications are published by The American Welding Society, P.O. Box 351040, Miami, Florida 33135. AWS publications may be purchased from the American Welding Society at <http://www.aws.org> or by contacting the AWS at 800-443-9353.

ANSI, Standard Z49.1, Safety in Welding, Cutting and Allied Processes. Z49.1 is now available for download at no charge at <http://www.lincolnelectric.com/community/safety/> or at the AWS website <http://www.aws.org>.

AWS F1.1, Method for Sampling Airborne Particulates Generated by Welding and Allied Processes.

AWS F1.2, Laboratory Method for Measuring Fume Generation Rates and Total Fume Emission of Welding and Allied Processes.

AWS F1.3, Evaluating Contaminants in the Welding Environment: A Strategic Sampling Guide.

AWS F1.5, Methods for Sampling and Analyzing Gases from Welding and Allied Processes.

AWS F3.2, Ventilation Guide for Welding Fume Control.

AWS F4.1, Recommended Safe Practices for the Preparation for Welding and Cutting of Containers and Piping That Have Held Hazardous Substances.

AWS SHF, Safety and Health Facts Sheets. Available free of charge from the AWS website at <http://www.aws.org>.

LISTED BELOW ARE SOME TYPICAL INGREDIENTS IN WELDING ELECTRODES AND THEIR TLV (ACGIH) GUIDELINES AND PEL (OSHA) EXPOSURE LIMITS

INGREDIENTS	CAS No.	TLV mg/m ³	PEL mg/m ³
Aluminum and/or aluminum alloys (as Al)*****	7429-90-5	10	15
Aluminum oxide and/or Bauxite*****	1344-28-1	10	5**
Barium compounds (as Ba)*****	513-77-9	****	****
Chromium and chromium alloys or compounds (as Cr)*****	7440-47-3	0.5(b)	.005(b)
Fluorides (as F)	7789-75-5	2.5	2.5
Iron	7439-89-6	10*	10*
Limestone and/or calcium carbonate	1317-65-3	10	15
Lithium compounds (as Li)	554-13-2	10*	10*
Magnesite	1309-48-4	10	15
Magnesium and/or magnesium alloys and compounds (as Mg)	7439-95-4	10*	10*
Manganese and/or manganese alloys and compounds (as Mn)*****	7439-96-5	0.2	5.0(c)
Mineral silicates	1332-58-7	5**	5**
Molybdenum alloys (as Mo)	7439-98-7	10	10
Nickel*****	7440-02-0	1.5	1
Silicates and other binders	1344-09-8	10*	10*
Silicon and/or silicon alloys and compounds (as Si)	7440-21-3	10*	10*
Strontium compounds (as Sr)	1633-05-2	10*	10*
Zirconium alloys and compounds (as Zr)	12004-83-0	5	5

Supplemental Information:

(*) Not listed. Nuisance value maximum is 10 milligrams per cubic meter. PEL value for iron oxide is 10 milligrams per cubic meter. TLV value for iron oxide is 5 milligrams per cubic meter.

(**) As respirable dust.

(****) Subject to the reporting requirements of Sections 311, 312, and 313 of the Emergency Planning and Community Right-to-Know Act of 1986 and of 40CFR 370 and 372.

(b) The PEL for chromium (VI) is .005 milligrams per cubic meter as an 8 hour time weighted average. The TLV for water-soluble chromium (VI) is 0.05 milligrams per cubic meter. The TLV for insoluble chromium (VI) is 0.01 milligrams per cubic meter.

(c) Values are for manganese fume. STEL (Short Term Exposure Limit) is 3.0 milligrams per cubic meter. OSHA PEL is a ceiling value.

(****) There is no listed value for insoluble barium compounds. The TLV for soluble barium compounds is 0.5 mg/m³.

TLV and PEL values are as of April 2006. Always check Material Safety Data Sheet (MSDS) with product or on the Lincoln Electric website at <http://www.lincolnelectric.com>

I - MASTER TABLE OF CONTENTS FOR ALL SECTIONS - I

	Page
Safety	ii-viii
<hr/>	
Installation, Operation, Accessories, Maintenance	See Instruction Manual
Theory of Operation	Section E
Troubleshooting and Repair	Section F
Electrical Diagrams	Section G

Theory of Operation E-1

General Description E-2

Battery, Starter, Engine, Rotor, Stator, Engine Protection E-2

Weld Windings, Rectifier, Chopper Modules and Feedback E-3

Weld Control Board E-4

Insulated Gate Bipolar Transistor (IGBT) Operation E-5

Pulse Width Modulation E-6

Chopper Technology Fundamentals E-7

FIGURE E.1 – VANTAGE® 400 BLOCK LOGIC DIAGRAM.

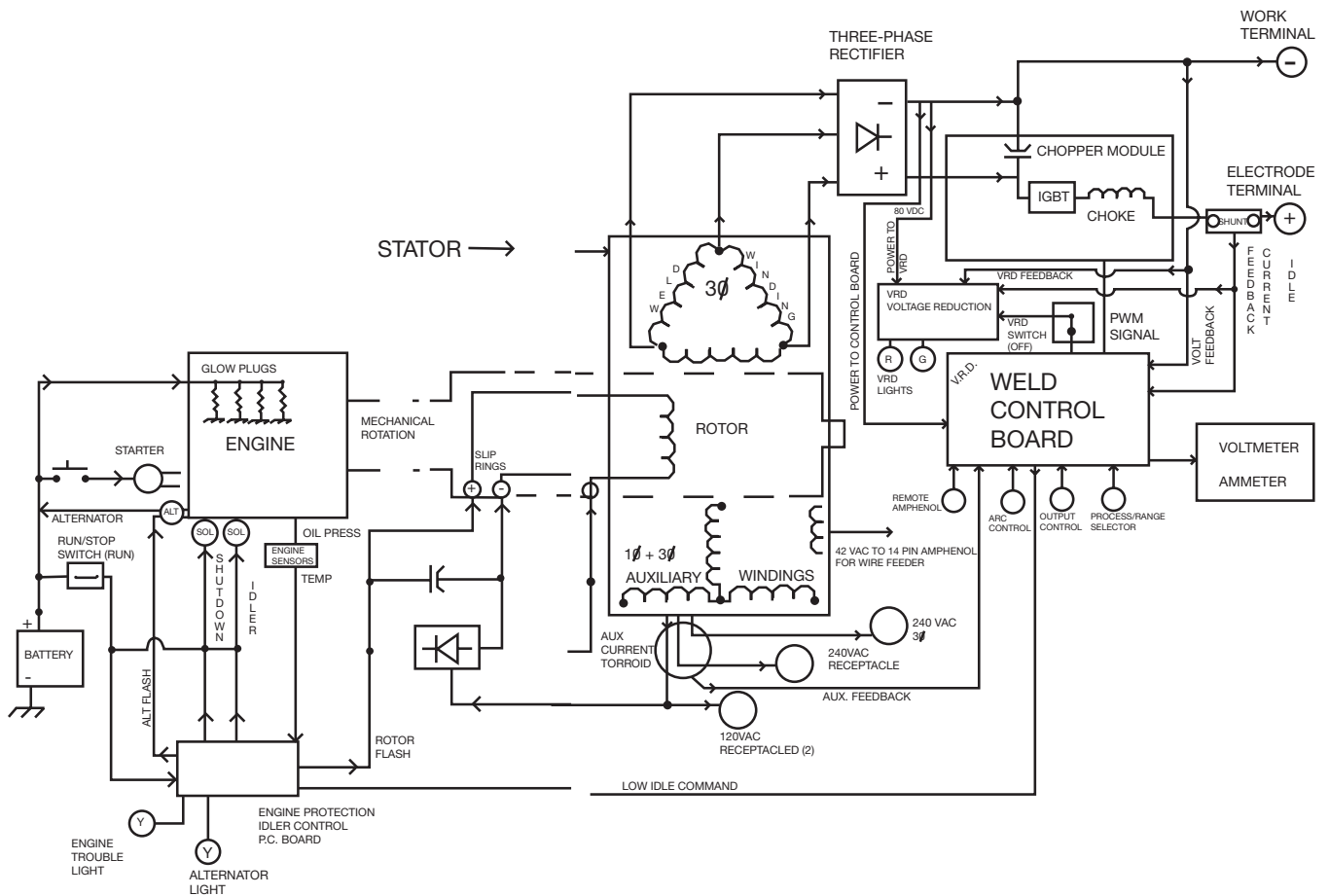
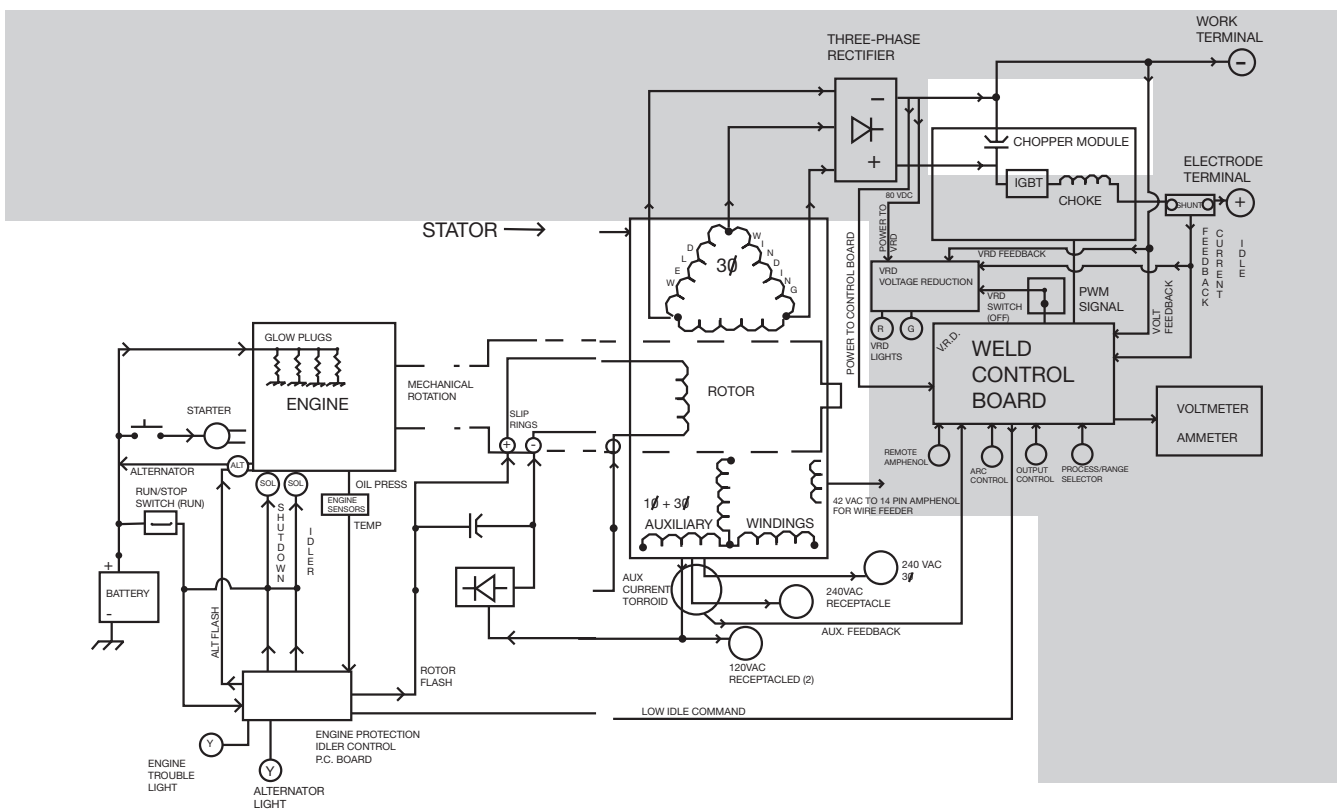

FIGURE E.2 – GENERAL DESCRIPTION, BATTERY, ENGINE, ROTOR, STATOR & ENGINE PROTECTION



GENERAL DESCRIPTION

The Vantage® 400 is a diesel engine-driven welding power source capable of producing 450 amps at 32VDC at a 100% duty cycle. The engine is coupled to a brush-type alternating current generator. This AC output is rectified and controlled by **Chopper Technology** to produce DC current for multi-purpose welding applications. The Vantage® 400 is also capable of producing 11,000 watts of AC auxiliary power at 100% duty cycle.

BATTERY, ENGINE, ROTOR, STATOR, PULL COIL BOARD AND PERIPHERAL BOARD – ENGINE PROTECTION

The 12VDC battery powers the engine starter motor and also supplies power to the Pull Coil PC board, Peripheral PC board and associated circuitry. When the engine, which is mechanically coupled to the rotor, is started and running, the 12 VDC battery voltage is

fed through the pull coil PC board to the rotor field coil via a brush and slip ring configuration. This excitation or “flashing” voltage magnetizes the rotor lamination. This rotating magnet induces a voltage in the stationary windings of the main alternator stator. The stator houses a three-phase weld winding, a 120/240VAC single-phase auxiliary winding, and a 42VAC wire feeder power winding.

The engine alternator supplies charging current for the battery circuit. The Peripheral board monitors the engine sensors and will shut the engine off in the event of low oil pressure, engine over temperature, malfunction of the engine’s alternator system or a low fuel condition. The idler solenoid is mechanically connected to the engine’s throttle linkage. If no welding or auxiliary current is being drawn from the Vantage® 400, the Pull Coil board activates the idler solenoid, which then brings the engine to a low idle state. When output current is sensed, either weld or auxiliary, the Weld Control PC board deactivates the idler solenoid, and the engine returns to high RPM.

NOTE: Unshaded areas of Block Logic Diagram are the subject of discussion

FIGURE E.3 — WELD WINDINGS, RECTIFIER, CHOPPER MODULES & FEEDBACK

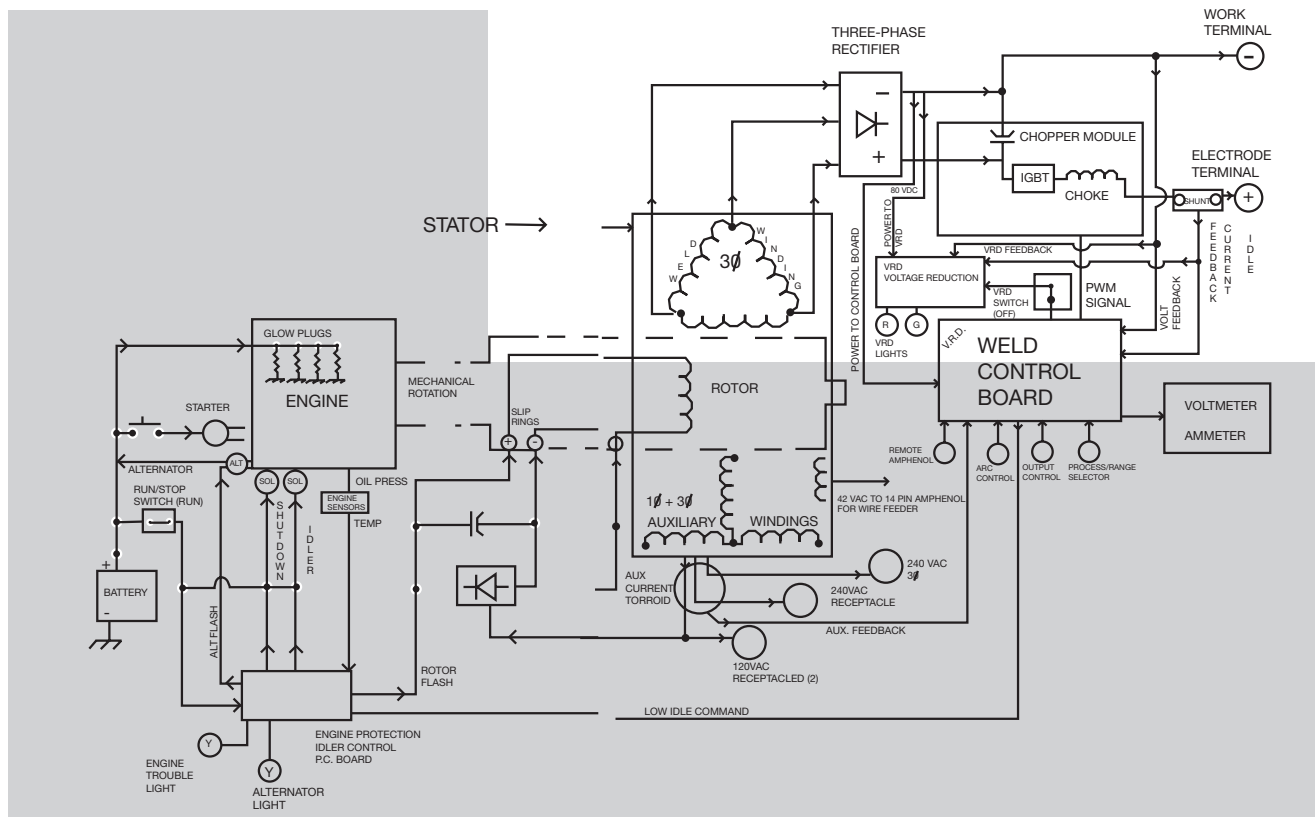

WELD WINDINGS, RECTIFIER, POWER MODULES AND FEEDBACK

The three-phase stator weld windings are connected to a three-phase rectifier bridge. The resultant DC voltage is applied to four paralleled capacitors incorporated within each of the two power modules. There are two capacitors in each module. These capacitors function as filters and also as power supplies for the IGBTs. See **IGBT Operation** in this section. The IGBTs act as high-speed switches operating at 20KHZ. These devices are switched on and off by the Weld Control PC board through pulse width modulation circuitry. See **Pulse Width Modulation** in this section.

This “chopped” DC output is applied through choke coils and a shunt to the welding output terminals. The choke functions as a current filter, and it helps to balance the outputs of the two power modules. Free-wheeling diodes are incorporated in the power modules to provide a current path for the stored energy in the choke when the IGBTs are turned off. See **Chopper Technology** in this section.

Output voltage and current feedback information is fed to the Weld Control PC board. This information is sensed from the output terminal circuits and the shunt.

NOTE: Unshaded areas of Block Logic Diagram are the subject of discussion

FIGURE E.4 – WELD CONTROL BOARD

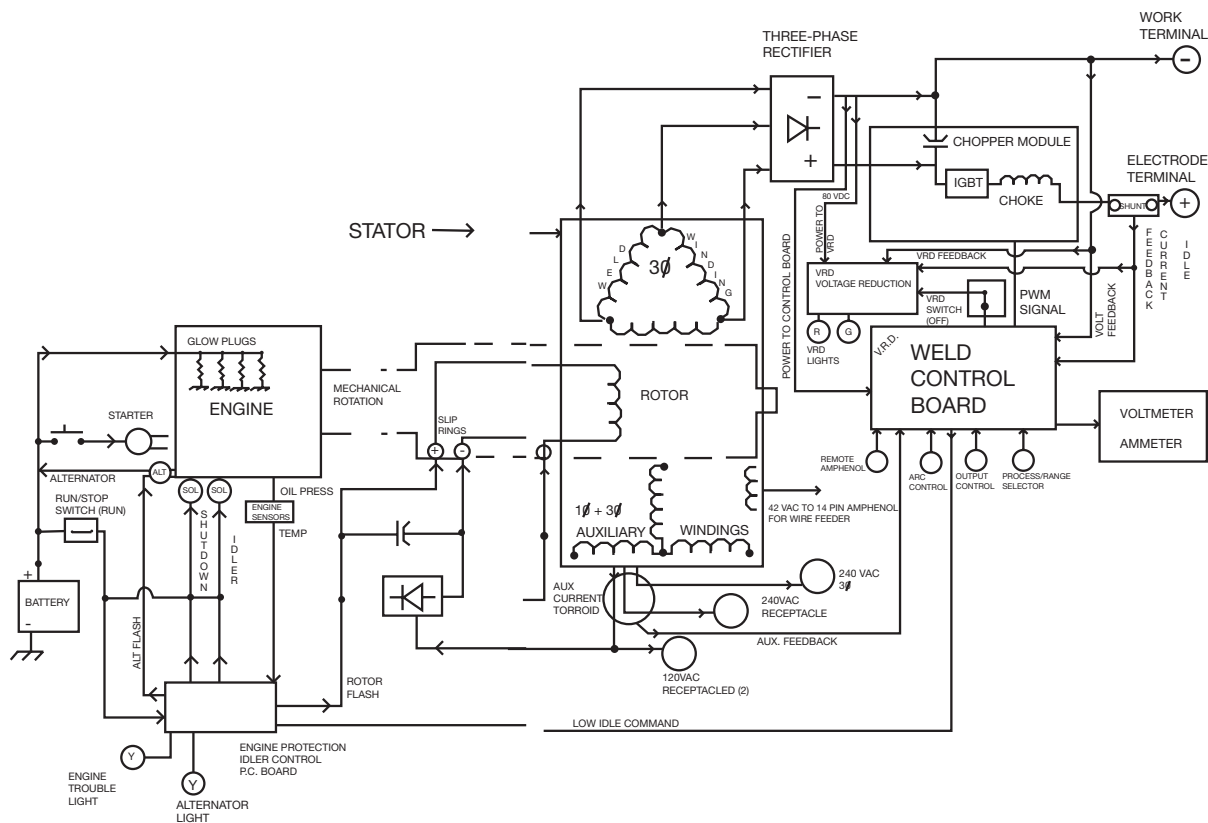

WELD CONTROL BOARD

The 80 VDC derived from the filter capacitors on the Power Modules, supplies various regulated DC voltages to operate the Weld Control PC board circuitry. It also supplies two regulated DC voltages to operate the IGBT driver circuitry on the two Power Modules.

The Weld Control PC board monitors the operator controls (arc control, output, and process/range selector). It compares these commands to the current and voltage feedback information it receives from the shunt

and output terminal circuits. The circuitry on the Weld Control PC board determines how the output should be controlled to optimize welding results, and it sends the correct PWM signals to the IGBT driver circuits. The Weld Control PC board also commands the thermal light and the voltmeter and ammeter (some items may be optional).

NOTE: Unshaded areas of Block Logic Diagram are the subject of discussion

FIGURE E.5 – IGBT OPERATION

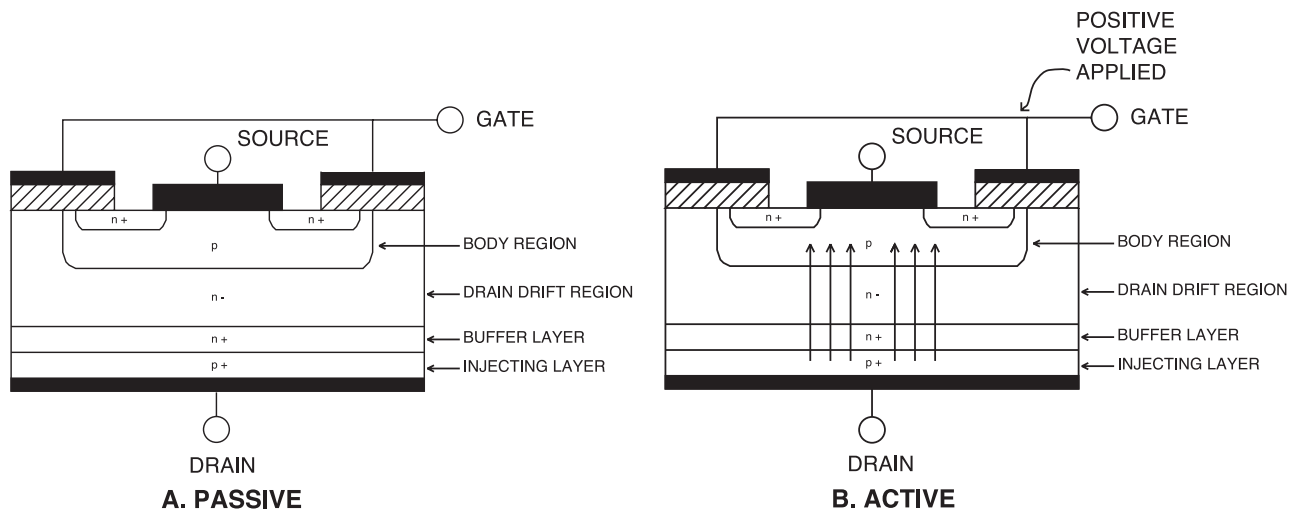

INSULATED GATE BIPOLAR TRANSISTOR (IGBT) OPERATION

An IGBT is a type of transistor. IGBTs are semiconductors well suited for high frequency switching and high current applications.

Drawing A shows an IGBT in a passive mode. There is no gate signal, zero volts relative to the source, and therefore, no current flow. The drain terminal of the IGBT may be connected to a voltage supply; but since there is no conduction the circuit will not supply current to components connected to the source. The circuit is turned off like a light switch in the OFF position.

Drawing B shows the IGBT in an active mode. When the gate signal, a positive DC voltage relative to the source, is applied to the gate terminal of the IGBT, it is capable of conducting current. A voltage supply connected to the drain terminal will allow the IGBT to conduct and supply current to circuit components coupled to the source. Current will flow through the conducting IGBT to downstream components as long as the positive gate signal is present. This is similar to turning ON a light switch.

FIGURE E.6 – TYPICAL IGBT OUTPUTS

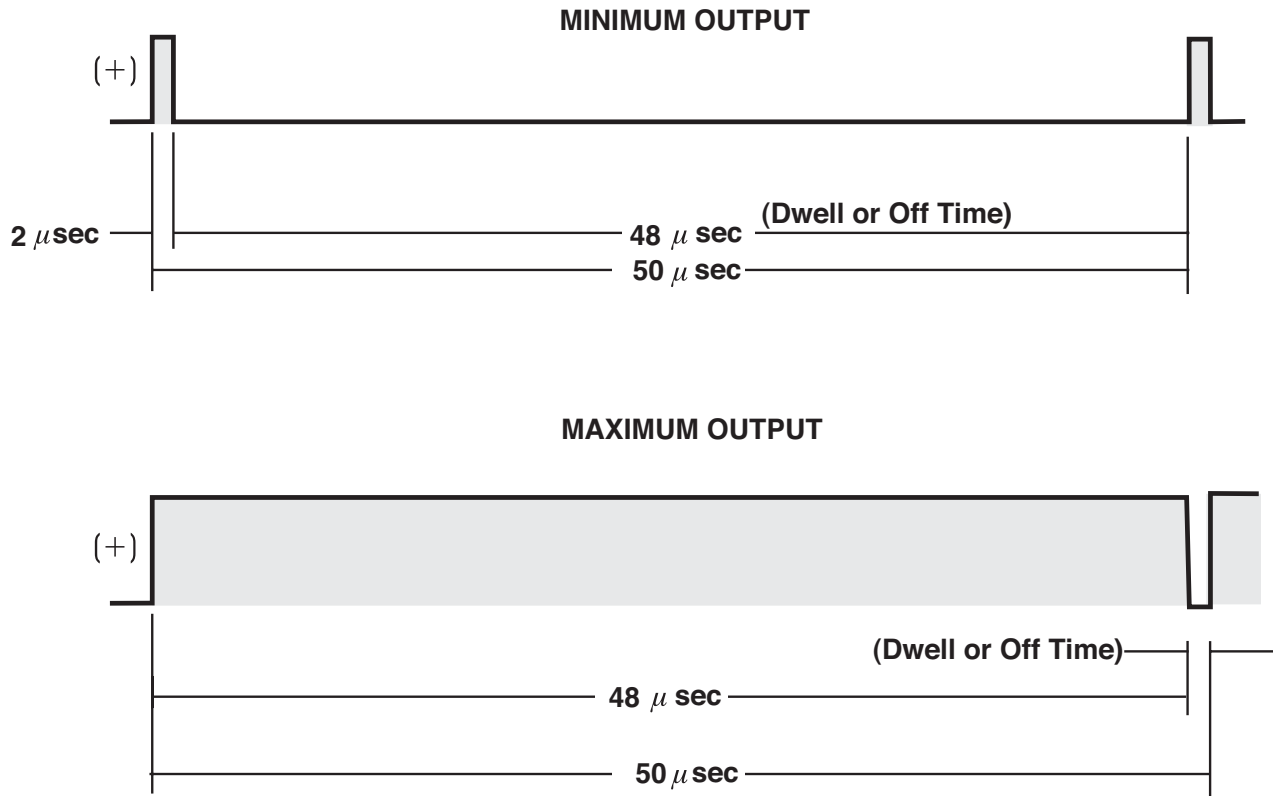

PULSE WIDTH MODULATION

The term PULSE WIDTH MODULATION is used to describe how much time is devoted to conduction in the cycle. Changing the pulse width is known as MODULATION. Pulse Width Modulation (PWM) is the varying of the pulse width over the allowed range of a cycle to affect the output of the machine.

MINIMUM OUTPUT

By controlling the duration of the gate signal, the IGBT is turned on and off for different durations during a cycle. The top drawing shows the minimum output signal possible over a 50-microsecond time period.

The positive portion of the signal represents one IGBT group conducting for 2 microsecond. The dwell time (off time) is 48 microseconds. Since only 2 microseconds of the 50-microsecond time period is devoted to conducting, the output power is minimized.

MAXIMUM OUTPUT

By holding the gate signals on for 48 microseconds and allowing only 2 microseconds of dwell time (off time) during the 50-microsecond cycle, the output is maximized. The darkened area under the top curve can be compared to the area under the bottom curve. The more darkened area under the curve, the more power is present.

CHOPPER TECHNOLOGY FUNDAMENTALS

The new era of welding machines such as the Vantage® 500, employ a technology whereby a DC source is turned on and off (chopped up) at high speed, then smoothed through an inductor to control an arc.

Hence the name “Chopper.” The biggest advantage® of chopper technology is the high-speed control of the arc, similar to the inverter machines. A block diagram for this is as follows:

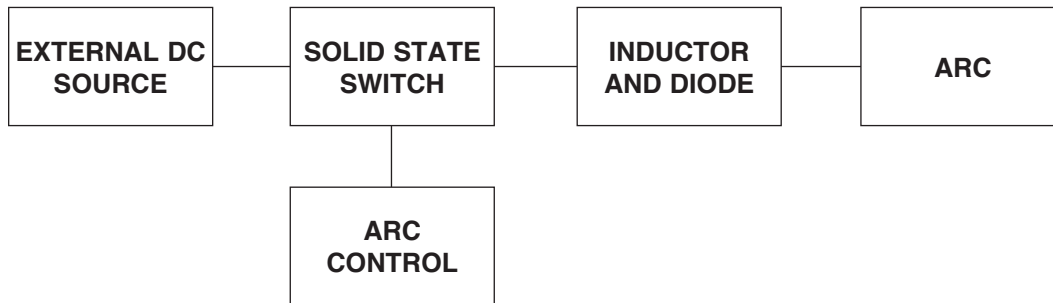

In this system, the engine drives a three-phase alternator, which generates power that is rectified and filtered to produce about 75VDC. The current is applied through a solid state switch to an inductor.

By turning the switch on and off, current in the inductor and the arc can be controlled. The following diagram depicts the current flow in the system when the switch is open and closed.

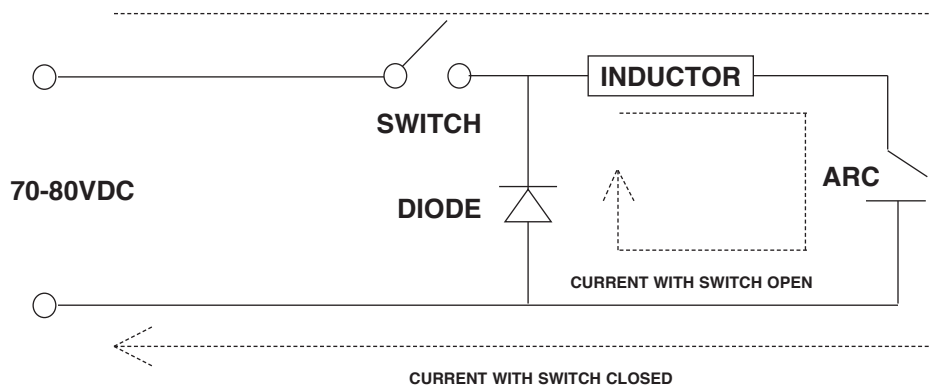

When the switch is closed, current is applied through the inductor to the arc. When the switch opens, current stored in the inductor sustains flow in the arc and through the diode. The repetition rate of switch closure is 20Khz, which allows ultra-fast control of the

arc. By varying the ratio of on time versus off time of the switch (Duty Cycle), the current applied to the arc is controlled. This is the basis for Chopper Technology: Controlling the switch in such a way as to produce superior welding.

Troubleshooting and Repair F-1

 How to Use Troubleshooting Guide F-2

 PC Board Troubleshooting Procedures F-3

 Troubleshooting Guide F-4 - F-20

 Case Cover Removal and Replacement Procedure F-21

 Chopper Module Capacitor Discharge Procedure F-25

 Fuel Shutdown Solenoid Test F-27

 Engine Throttle Adjustment Test F-29

 Idle Solenoid Test F-33

 Engine Alternator Test F-35

 Brush and Slip Ring Service Procedure F-37

 Rotor Resistance and Grounding Test (Static) F-39

 Rotor Resistance and Ground Test (Dynamic) F-41

 Rotor Voltage Test F-43

 Flashing Voltage Test F-47

 Stator Voltage Tests F-51

 Stator Short Circuit & Ground Test F-55

 Output Rectifier Bridge Test F-57

 Chopper Module Function Test F-61

 Chopper Module Resistance Test F-65

 Weld Control Board PWM Gate Signal Test F-69

 Weld Control Feedback Test F-71

 Control Potentiometer and Mode Switch Resistance Test F-75

 Remote Receptacle Resistance Test F-79

 Voltage Waveforms F-82 - F-86

 Output Rectifier Bridge and Choke Removal and Replacement F-87

 Chopper Module Removal and Replacement F-91

 Stator/Rotor Removal and Replacement F-95

 Retest after Repair F-104

HOW TO USE TROUBLESHOOTING GUIDE

 **WARNING**

Service and Repair should only be performed by Lincoln Electric Factory Trained Personnel. Unauthorized repairs performed on this equipment may result in danger to the technician and machine operator and will invalidate your factory warranty. For your safety and to avoid Electrical Shock, please observe all safety notes and precautions detailed throughout this manual.

This Troubleshooting Guide is provided to help you locate and repair possible machine malfunctions. Simply follow the three-step procedure listed below.

Step 1. LOCATE PROBLEM (SYMPTOM).

Look under the column labeled "PROBLEM (SYMPTOMS)". This column describes possible symptoms that the machine may exhibit. Find the listing that best describes the symptom that the machine is exhibiting. Symptoms are grouped into the following categories: output problems, function problems, welding problems, engine problems and output problems.

Step 2. PERFORM EXTERNAL TESTS.

The second column labeled "POSSIBLE AREAS OF MISADJUSTMENT(S)" lists the obvious external possibilities that may contribute to the machine symptom. Perform these tests/checks in the order listed. In general, these tests can be conducted without removing the case wrap-around cover.

Step 3. RECOMMENDED COURSE OF ACTION

The last column labeled "Recommended Course of Action" lists the most likely components that may have failed in your machine. It also specifies the appropriate test procedure to verify that the subject component is either good or bad. If there are a number of possible components, check the components in the order listed to eliminate one possibility at a time until you locate the cause of your problem.

All of the referenced test procedures referred to in the Troubleshooting Guide are described in detail at the end of this chapter. Refer to the Troubleshooting and Repair Table of Contents to locate each specific Test Procedure. All of the specified test points, components, terminal strips, etc. can be found on the referenced electrical wiring diagrams and schematics. Refer to the Electrical Diagrams Section Table of Contents to locate the appropriate diagram.

 **CAUTION**

If for any reason you do not understand the test procedures or are unable to perform the tests/repairs safely, contact the Lincoln Electric Service Department for technical troubleshooting assistance before you proceed. Call 1-888-935-3877.

PC BOARD TROUBLESHOOTING PROCEDURES



WARNING



ELECTRIC SHOCK can kill.

- Have an electrician install and service this equipment. Turn the input power OFF at the fuse box before working on equipment. Do not touch electrically hot parts.



CAUTION

Sometimes machine failures appear to be due to PC board failures. These problems can sometimes be traced to poor electrical connections. To avoid problems when troubleshooting and replacing PC boards, please use the following procedure:

1. Determine to the best of your technical ability that the PC board is the most likely component causing the failure symptom.
2. Check for loose connections at the PC board to assure that the PC board is properly connected.
3. If the problem persists, replace the suspect PC board using standard practices to avoid static electrical damage and electrical shock. Read the warning inside the static resistant bag and perform the following procedures:

PC board can be damaged by static electricity.



ATTENTION Static-Sensitive Devices Handle only at Static-Safe Workstations

- Remove your body's static charge before opening the static-shielding bag. Wear an anti-static wrist strap. For safety, use a 1 Meg ohm resistive cord connected to a grounded part of the equipment frame.
- If you don't have a wrist strap, touch an un-painted, grounded, part of the equipment frame. Keep touching the frame to prevent static build-up. Be sure not to touch any electrically live parts at the same time.

- Tools which come in contact with the PC board must be either conductive, anti-static or static-dissipative.

- Remove the PC board from the static-shielding bag and place it directly into the equipment. Don't set the PC board on or near paper, plastic or cloth which could have a static charge. If the PC board can't be installed immediately, put it back in the static-shielding bag.

- If the PC board uses protective shorting jumpers, don't remove them until installation is complete.

- If you return a PC board to The Lincoln Electric Company for credit, it must be in the static-shielding bag. This will prevent further damage and allow proper failure analysis.

4. Test the machine to determine if the failure symptom has been corrected by the replacement PC board.

NOTE: It is desirable to have a spare (known good) PC board available for PC board troubleshooting.

NOTE: Allow the machine to heat up so that all electrical components can reach their operating temperature.

5. Remove the replacement PC board and substitute it with the original PC board to recreate the original problem.
 - a. If the original problem does not reappear by substituting the original board, then the PC board was not the problem. Continue to look for bad connections in the control wiring harness, junction blocks, and terminal strips.
 - b. If the original problem is recreated by the substitution of the original board, then the PC board was the problem. Reinstall the replacement PC board and test the machine.
6. Always indicate that this procedure was followed when warranty reports are to be submitted.

NOTE: Following this procedure and writing on the warranty report, "INSTALLED AND SWITCHED PC BOARDS TO VERIFY PROBLEM," will help avoid denial of legitimate PC board warranty claims.

Observe Safety Guidelines detailed in the beginning of this manual.

PROBLEMS (SYMPTOMS)	POSSIBLE AREAS OF MISADJUSTMENT(S)	RECOMMENDED COURSE OF ACTION
OUTPUT PROBLEMS		
Major mechanical or electrical damage is evident.	1. Contact your local Lincoln Authorized Field Service Facility.	1. Contact the Lincoln Electric Service Department at 1-888-935-3877.
No welding output or auxiliary power. The engine operates normally.	<p>Check for loose or faulty connections in the auxiliary circuit to the output receptacles, and/or the weld circuit to the output terminals. SEE WIRING DIAGRAM.</p> <p>Check the brushes for wear and proper contact to the rotor slip rings.</p>	<p>Check the brushes for wear and proper contact to the rotor slip rings</p> <p>Perform the Brush and Slip Ring Service Procedure.</p> <p>Check for flashing voltage at slip rings (3-5 Volts DC @ .5 amp until generator builds up, then 160 Volts) See FLASHING VOLTAGE TEST.</p> <p>Check Field rectifier and capacitor.</p> <p>Perform the Rotor Voltage Test.</p> <p>Perform the Stator Voltage Test.</p>

 **CAUTION**

If for any reason you do not understand the test procedures or are unable to perform the tests/repairs safely, contact the Lincoln Electric Service Department for technical troubleshooting assistance before you proceed. Call 1-888-935-3877.

VANTAGE® 400



Observe Safety Guidelines detailed in the beginning of this manual.

PROBLEMS (SYMPTOMS)	POSSIBLE AREAS OF MISADJUSTMENT(S)	RECOMMENDED COURSE OF ACTION
OUTPUT PROBLEMS		
<p>No welding output in any mode. The auxiliary output is normal. The engine operates normally.</p>	<p>Place the Welding Terminals switch in the "WELD TERMINALS ON" If the problem is solved and there is a control cable, wire feeder, amptrol, or arc start switch connected, the fault may lie in the above attached accessories.</p> <p>If the correct OCV is present at the weld output terminals, check the welding cables, connectors, work clamp, electrode holder, etc. For loose or faulty connections.</p>	<p>Check for damaged conductors or faulty connections on the heavy current carrying leads that connect the output studs to the Chopper module and to the Output Rectifier. Also check the shunt and the choke assemblies for damage and faulty connections.</p> <p>Check the Welding Terminals Switch and the associated leads. See Wiring Diagram.</p> <p>Check gate leads #23 and #25 and Weld Control Board power leads #13 and #14 for loose or faulty connections. See Wiring Diagram.</p> <p>Perform the Chopper Module Function Test.</p> <p>Perform the STATOR VOLTAGE TEST.</p> <p>Perform the OUTPUT RECTIFIER TEST.</p> <p>The WELD CONTROL board may be faulty.</p>

 **CAUTION**

If for any reason you do not understand the test procedures or are unable to perform the tests/repairs safely, contact the Lincoln Electric Service Department for technical troubleshooting assistance before you proceed. Call 1-888-935-3877.

VANTAGE® 400



Observe Safety Guidelines detailed in the beginning of this manual.

PROBLEMS (SYMPTOMS)	POSSIBLE AREAS OF MISADJUSTMENT(S)	RECOMMENDED COURSE OF ACTION
OUTPUT PROBLEMS		
No output in PIPE MODE. Outputs normal in other modes.	Make sure VRD ON/OFF toggle switch is in the off position. Faulty CONTROL PC BOARD. Faulty VRD display board.	Check the connections at the VRD ON/OFF switch. Check the VRD on off switch for proper function/continuity. See VRD functional description
VRD lights don't light up.	Ensure VRD ON/OFF switch is in the "ON" position. VRD light may be burned out, replace both VRD lights. Faulty VRD display P.C. Board.	Check connections at the VRD ON/OFF switch. Check the VRD on off switch for proper? See VRD functional description.
No auxiliary power at one or more receptacles or at the 14 pin Amphenol. Weld output is normal and the engine operates normally.	Check for loose or faulty connections at the output receptacles or 14 pin amphenol. Check for tripped circuit breaker and/or tripped GFCI receptacles.	Perform the Stator Voltage Test . Check the wiring between the auxiliary receptacle and the main stator.
The machine has low welding output and low auxiliary output.	The engine RPM may be low. The brushes may be sticking, poorly seated or slip rings dirty.	Then engine high idle speed may be low. Perform the Engine Throttle Test (Electronic Idler) . Full load speed should be about 3500 RPM. Inspect and if necessary service the brushed and slip rings per the Brush and Slip Ring Service . Perform the Rotor Voltage Test . Perform the Stator Voltage Test .

 **CAUTION**

If for any reason you do not understand the test procedures or are unable to perform the tests/repairs safely, contact the Lincoln Electric Service Department for technical troubleshooting assistance before you proceed. Call 1-888-935-3877.

VANTAGE® 400



Observe Safety Guidelines detailed in the beginning of this manual.

PROBLEMS (SYMPTOMS)	POSSIBLE AREAS OF MISADJUSTMENT(S)	RECOMMENDED COURSE OF ACTION
FUNCTION PROBLEMS		
<p>The machine will weld but the welding arc is "COLD". The engine runs normally and the auxiliary power is normal.</p>	<p>Make sure the machine is properly set for the electrode and process is being used. Check electrode size, mode switch setting, and amps or voltage setting. If gas is used make sure of correct type and gas flow.</p> <p>Make sure the process does not demand more power than the machine can produce.</p> <p>If the current is correct try increasing the "ARC CONTROL" setting.</p> <p>Check for loose or faulty connections at the weld output terminals and welding cable connections.</p> <p>Check for good connections between the work cable and the work piece. The work cable should be attached to clean metal, as close to the weld area as possible. The work clamp must be in good condition with good spring tension.</p> <p>The weld cables may be too long, or too small diameter causing excessive voltage drop.</p> <p>The weld cables may be coiled, or wrapped around metal racks or reels. This can cause excessive inductance in the weld circuit.</p> <p>Try welding with a short set of adequately sized weld cables.</p>	<p>The engine RPM may be too low. Perform the Engine Throttle Adjustment Test.</p> <p>Connect the machine to a resistive load bank. Connect an accurate ammeter and volt meter to the output of the machine. Connect a tachometer, Hz meter or another method to measure engine RPM. Place the mode switch in "CC-STICK, turn the output control to maximum idle switch to "HIGH" terminal switch to "WELD TERMINALS ON".</p> <p>Nothing else attached or plugged into machine (No aux., no control cables). Start the machine allow the engine to reach normal operating temperature. Apply a load with the load bank. Load to 300 Amps, 32 Volts, 100% Duty Cycle.</p> <p>The engine should maintain 3350 RPM.</p> <p>If the engine cannot maintain the RPM make sure there is a supply of clean fresh fuel.</p> <p>Check the fuel filter and the air filter.</p> <p>Replace any filter that is dirty; or damaged.</p> <p>If this doesn't help have the engine serviced.</p> <p>Compare the volt and amp readings displayed on the machine with that of the load bank. If these are significantly different, perform the WELD CONTROL FEEDBACK TEST.</p>

 **CAUTION**

If for any reason you do not understand the test procedures or are unable to perform the tests/repairs safely, contact the Lincoln Electric Service Department for technical troubleshooting assistance before you proceed. Call 1-888-935-3877.

Observe Safety Guidelines detailed in the beginning of this manual.

PROBLEMS (SYMPTOMS)	POSSIBLE AREAS OF MISADJUSTMENT(S)	RECOMMENDED COURSE OF ACTION
FUNCTION PROBLEMS		
<p>The machine will weld but the welding arc is "COLD". The engine runs normally and the auxiliary power is normal. (continued)</p>		<p>If the maximum weld output cannot be obtained even though the front panel displays are reading accurately, check for damaged conductors and loose or damaged connections the large current carrying conductor connect the stator, output rectifier, chopper modules, choke, shunt, and output terminals. See <i>the Wiring Diagram</i>. If all these connections are good perform the ROTOR VOLTAGE TEST, the STATOR VOLTAGE TEST, the OUTPUT RECTIFIER TEST, and the CHOPPER MODULE RESISTANCE TEST. Perform the CONTROL POTENTIOMETER AND MODE RESISTANCE TEST. Perform the REMOTE RECEPTACLE RESISTANCE TEST. Replace the Control P.C. Board.</p>
<p>The machine welds but it will not maintain a steady output.</p>	<p>This condition may be normal in the Downhill Pipe Mode. The downhill pipe mode allows the arc current to increase and decrease slightly as the arc length changes. Check that the electrode is of good quality, dry and free from contamination. Try using some Lincoln Electrode, and setting the machine per Lincoln recommendation. If shielding gas is used, check that the gas and gas flow are correct. Check for damaged, pinched or leaking gas lines. Check for proper work, and electrode leads and connections (size, length, coils, or bad connections).</p>	<p>The machine may not be maintaining the correct RPM. Perform the THROTTLE ADJUSTMENT TEST. If the engine will not maintain the correct load RPM, the engine may be servicing fuel, air, and fuel filters should be checked.</p> <p>Check internal cables and leads that connect the weld winding of the stator, chopper module and the shunt, choke and output terminals. See <i>the wiring diagram</i>. Look for damaged conductors or faulty connections.</p>

 **CAUTION**

If for any reason you do not understand the test procedures or are unable to perform the tests/repairs safely, contact the Lincoln Electric Service Department for technical troubleshooting assistance before you proceed. Call 1-888-935-3877.

VANTAGE® 400



Observe Safety Guidelines detailed in the beginning of this manual.

PROBLEMS (SYMPTOMS)	POSSIBLE AREAS OF MISADJUSTMENT(S)	RECOMMENDED COURSE OF ACTION
ENGINE PROBLEMS		
<p>The machine welds but it will not maintain a steady output. (continued)</p>		<p>There may be poor connections in the control wiring at the weld control P.C. Board, or the chopper board. Pull each plug from the weld P.C. board and thoroughly inspect the terminals in both the plugs and the P.C. Board receptacles. Make sure the connections are clean and the pins are properly seated in the plastic plug housing. Check for loose or damaged pins and faulty crimps.</p> <p>Check for damaged wiring and poor connections in the 13, 14, and the 23, and 25 leads, between the chopper module and weld control P.C. Board.</p> <p>The output control or the arc control potentiometer may be defective or grounded. The mode switch may also be faulty. Perform the POTENTIOMETER AND MODE SWITCH RESISTANCE TEST.</p> <p>The Amphenol receptacles may be contaminated or defective. Perform the REMOTE RECEPTACLE RESISTANCE TEST.</p> <p>Replace the weld control P.C. Board.</p>

 **CAUTION**

If for any reason you do not understand the test procedures or are unable to perform the tests/repairs safely, contact the Lincoln Electric Service Department for technical troubleshooting assistance before you proceed. Call 1-888-935-3877.

Observe Safety Guidelines detailed in the beginning of this manual.

PROBLEMS (SYMPTOMS)	POSSIBLE AREAS OF MISADJUSTMENT(S)	RECOMMENDED COURSE OF ACTION
ENGINE PROBLEMS		
<p>The weld output can not be adjusted with the front panel output control knob in one or mode weld modes. The weld output terminals have normal OCV (open circuit voltage). The AC auxiliary power is normal and the engine operated normally.</p>	<p>Remote control devices completely disables the front output in all modes except touch start TIG mode. Make sure there is nothing plugged into the Amphenol receptacles. Check for dirt or moisture contamination in either the 6 pin or the 14 pin amphenol.</p>	<p>Perform the REMOTE RECEPTACLE RESISTANCE TEST. The output control potentiometer may be defective. Perform the CONTROL POTENTIOMETER AND MODE SWITCH RESISTANCE TEST. The WELD CONTROL BOARD may be faulty. See the Start-Up and OCV diagnostic chart.</p>
<p>The machine front panel output control is still active when the remote control unit is connected to one of the Front Panel Amphenols.</p>	<p>This condition is normal in the "TOUCH START TIG MODE". See the operators manual. The remote control unit may be defective. Check the Amphenol receptacles. Look for damage or corroded contact pins in the receptacle and in the plug of the remote control unit.</p>	<p>Check plug #P1 on the control P.C. Board. Plug should be properly seated and the pins in both the plug and the P.C. Board jack must be clean and fit tightly together. There may be a poor connection between the weld control P.C. Board and the amphenol receptacles. Check for continuity between the following terminals. See Wiring Diagram and Control Inner-Connection Diagram. P1-10 to 6 pin amphenol pin "C" and to pin 14 amphenol pin "G". P-1-11 to 6 pin amphenol pin "A" and to 14 pin amphenol pin "E". P-1-14 to 6 pin amphenol pin "B" and to 14 pin amphenol pin "F". The weld control P.C. Board may be defective.</p>

 **CAUTION**

If for any reason you do not understand the test procedures or are unable to perform the tests/repairs safely, contact the Lincoln Electric Service Department for technical troubleshooting assistance before you proceed. Call 1-888-935-3877.

Observe Safety Guidelines detailed in the beginning of this manual.

PROBLEMS (SYMPTOMS)	POSSIBLE AREAS OF MISADJUSTMENT(S)	RECOMMENDED COURSE OF ACTION
ENGINE PROBLEMS		
<p>The machine seems to be locked into the “CC-stick” mode of operation.</p>	<p>Check the position of the WELD MODE selector switch. The switch should positively snap into each mode position and should not feel gritty or get stuck between positions.</p>	<p>Check that plug P-7 is fully seated into the weld control P.C. board socket. See Control Inner-Connection diagram. Check for corroded, dirty, or damaged Molex terminals in plug P-7, also check for similar problems in socket J-7 on the weld control P.C. board. Check the wiring between the control P.C. Board and the mode switch. Look for poor crimp and solder connections as well as damaged wiring or insulation. See wiring diagram. Perform the CONTROL POTENTIOMETER AND MODE SWITCH RESISTANCE TEST. The Weld control P.C. Board may be faulty.</p>
<p>The arc quality is poor with excessive spatter. The arc heat can be controlled and maintained normally, the auxiliary output is normal and the engine operates normally.</p>	<p>The ARC CONTROL may be set too high. The output control may be set too high for the electrode being used. Check that the electrode is of good quality, dry and free from contamination. Try using some Lincoln Electrode, and setting the machine per Lincoln’s recommendation. If shielding gas is used, check that the gas and gas flow are correct. Check for damaged, pinched, or leaking gas lines. Check for proper work, and electrode leads and connections (size, length, coils, or bad connections).</p>	<p>Check that the weld circuit isn’t grounded. With the engine off, check the resistance between chassis ground and the weld output terminals. The resistance should be very high, a minimum of 500,000 (500k) Ohms. The weld control system may be grounded or malfunctioning. Perform the CONTROL POTENTIOMETER and MODE SWITCH TEST, and the REMOTE RECEPTACLE RESISTANCE TEST. The Chopper module may be defective. Perform the CHOPPER MODULE RESISTANCE TEST.</p>

 **CAUTION**

If for any reason you do not understand the test procedures or are unable to perform the tests/repairs safely, contact the Lincoln Electric Service Department for technical troubleshooting assistance before you proceed. Call 1-888-935-3877.

Observe Safety Guidelines detailed in the beginning of this manual.

PROBLEMS (SYMPTOMS)	POSSIBLE AREAS OF MISADJUSTMENT(S)	RECOMMENDED COURSE OF ACTION
WELDING PROBLEMS		
<p>The machine welds normally in all modes and the range of weld output seems normal, but one or both of the front panel displays is blank, incorrect welding value, or displays parts of numbers.</p>	<p>It is normal for one of the displays to be off when there is no load across the weld output terminals. In "CV" - mode only the "VOLTS" display will be illuminated, in all other modes only the "AMPS" display will be illuminated. When welding both displays should be reading actual welding parameters.</p>	<p>Both the "AMPS" and "VOLTS" displays use the same part numbered display unit. If one of the digital displays appears to be functioning normally, it can be used to test the weld control P.C. Board output to the malfunctioning display.</p> <p>Swap the display board connectors on the weld control board (they are both the same), if the good display functions normally in bad displays place then the P.C. Board is good and only the malfunctioning display should be replaced.</p> <p>If the known good display still malfunctions then the weld control P.C. board is defective and should be replaced.</p>
<p>A control cable type feeder does not function when connected to the 14 pin amphenol. Machine operates normally in the "CC-STICK" mode and has normal AC auxiliary output.</p>	<p>Check the circuit breaker CB1 if using a 120 Volt AC wire feeder. Check CB8 if using a 42 VAC wire feeder. Reset breaker if tripped. Check the Amphenol receptacle for damaged, corroded or dirty contact pins.</p> <p>The wire feeder control cable may be defective. The wire feeder may be defective.</p>	<p>Use a volt meter to check for the presence of supply voltage at the 14 pin Amphenol receptacle. 120 Volt AC power supplied through pins A and J, 42 VAC power is supplied through pins I and K. Perform the STATOR VOLTAGE TEST.</p>

 **CAUTION**

If for any reason you do not understand the test procedures or are unable to perform the tests/repairs safely, contact the Lincoln Electric Service Department for technical troubleshooting assistance before you proceed. Call 1-888-935-3877.

Observe Safety Guidelines detailed in the beginning of this manual.

PROBLEMS (SYMPTOMS)	POSSIBLE AREAS OF MISADJUSTMENT(S)	RECOMMENDED COURSE OF ACTION
OUTPUT PROBLEMS		
<p>An Across-the-Arc type wire feeder does not function when connected to the weld output of the machine. The Vantage® operated normally in the CC-STICK mode, and has normal AC auxiliary output.</p>	<p>Check that the welding terminals switch is in the “WELD TERMINALS ON” position. Check the that WELD MODE switch is in the correct position for the process being used, typically “CV-WIRE” mode. Check for poor weld cable connections between the feeder and the welder output terminal, and between the work and the other output terminal. Check that the wire feeder’s work sensing lead is properly connected to the work piece and is in good condition. The wire feeder may be defective.</p>	<p>Use a voltmeter to check for the presence of about 58 VDC open circuit voltage (OCV) across the output studs of the machine. If the OCV is low, there may be a problem with the mode switch. Perform the CONTROL POTENTIOMETER AND WELD MODE SWITCH RESISTANCE TEST.</p> <p>If there is no OCV, see the troubleshooting sections for “No weld output in any mode”.</p>
<p>The engine will not crank when the start button is pushed.</p>	<p>Check the circuit breaker (CB5). Reset if tripped. Make sure the run/stop switch is in the “RUN” position. Check for loose or faulty battery cable connections. See wiring diagram. The battery may be low or faulty. If the battery will not accept a charge replace it. The starter or starter solenoid may be faulty (have the engine serviced at an authorized engine repair shop).</p>	<p>Check the wiring and the connections at the starter motor, glow plug button, CB5 circuit breaker, run / stop switch and the start button. See wiring diagram. Check the chassis ground connections between the engine block and the negative battery terminal. Place the run/stop switch to the “RUN” position. Press the start button, while checking for voltage between a good clean chassis ground connection (-) and lead #231 (+) at the starter solenoid. See the wiring diagram. If not voltage is present, check the start button, the run/stop switch and the CB5 circuit ground breaker. See wiring diagram. If battery voltage is present, the starter motor or solenoid may be defective, or the engine may be prevented from turning due a mechanical failure.</p>

 **CAUTION**

If for any reason you do not understand the test procedures or are unable to perform the tests/repairs safely, contact the Lincoln Electric Service Department for technical troubleshooting assistance before you proceed. Call 1-888-935-3877.

Observe Safety Guidelines detailed in the beginning of this manual.

PROBLEMS (SYMPTOMS)	POSSIBLE AREAS OF MISADJUSTMENT(S)	RECOMMENDED COURSE OF ACTION
OUTPUT PROBLEMS		
The battery does not stay charged.	Check for loose, corroded, or faulty connections at the battery. Check for loose or damaged alternator drive belt. The battery may be faulty.	Perform the ENGINE ALTERNATOR TEST . There may be a defective component or faulty wiring, causing a current draw when the run/stop switch is in the "stop" position. Check the Run/Stop switch, the glow plug button, the alternator and the starter solenoid. Also check for damaged wiring and insulation. If the engine charging system is operating properly but the battery is not staying charged, the battery is defective and should be replaced.
The engine cranks when the start button is pressed but will not start.	The battery voltage may be low (normally results in slow cranking speed). The batter should be checked and recharged if it is not producing adequate voltage, and replace if it will not accept a full charge. Make sure the glow plug button is pressed while pressing the start button. See the operator's manual, or the operation section of this manual for proper starting procedure. Make sure the fuel valve on the fuel sediment filter is in the open position. Check that the machine has an adequate supply of fresh, clean fuel. The fuel filter may be clogged, replace if necessary. Check the oil level.	The fuel solenoid may be faulty or not operating properly. Check lead #233, and #262 and perform the FUEL SHUT DOWN SOLENOID TEST . The Engine Protection Board may be faulty. The engine may be in need of mechanical repairs.

 **CAUTION**

If for any reason you do not understand the test procedures or are unable to perform the tests/repairs safely, contact the Lincoln Electric Service Department for technical troubleshooting assistance before you proceed. Call 1-888-935-3877.

Observe Safety Guidelines detailed in the beginning of this manual.

PROBLEMS (SYMPTOMS)	POSSIBLE AREAS OF MISADJUSTMENT(S)	RECOMMENDED COURSE OF ACTION
OUTPUT PROBLEMS		
<p>The engine starts but shuts down immediately when the start button is released.</p>	<p>Make sure the glow plug button is pressed while pushing the start button, and held until the engine protection light turns off (5 SECONDS MAXIMUM AFTER THE ENGINE STARTS.). See the operator's manual, or the operating section of this manual for proper starting procedure. Check the oil level. Be certain that the engine is not overheated. Check that the machine had adequate supply of fresh, clean fuel. The fuel filter may be clogged. Replace if necessary.</p>	<p>The shut down fuel solenoid may be faulty or not operating properly. Check lead #233 and #262 and perform the FUEL SHUT DOWN SOLENOID TEST. See wiring diagram.</p> <p>The check for the presents of 12 volts at the lead #233, when start button is pushed. Check CB5, and lead #231.</p> <p>The Engine Protection Board may be faulty.</p> <p>The engine may have inadequate oil pressure.</p> <p>The oil pressure switch or coolant temperature switch may be faulty.</p>
<p>The engine shuts down shortly after starting.</p>	<p>Check for adequate supply of clean fresh fuel. Check fuel and air filters, replace if necessary. Check oil level, add oil as required. Look for oil leakage. Check for loose or faulty battery cable connections.</p>	<p>The oil pressure switch or coolant temperature switch may be faulty. Make sure the engine has oil and oil pressure and engine is not overheated. Disconnect lead 234 from Engine Protection PC Board, of engine continues to run oil pressure switch or Temperature Switch is faulty. Check for faulty run/stop switch. Check for damaged insulation in the wiring between the engine protection relay and the oil pressure and coolant temperature switches. See wiring diagram.</p>

 **CAUTION**

If for any reason you do not understand the test procedures or are unable to perform the tests/repairs safely, contact the Lincoln Electric Service Department for technical troubleshooting assistance before you proceed. Call 1-888-935-3877.

Observe Safety Guidelines detailed in the beginning of this manual.

PROBLEMS (SYMPTOMS)	POSSIBLE AREAS OF MISADJUSTMENT(S)	RECOMMENDED COURSE OF ACTION
OUTPUT PROBLEMS		
The engine shuts down shortly after starting.		Check for poor electrical connections at the run/stop switch, and the fuel shutdown solenoid. See wiring diagram . The fuel solenoid may be faulty. Perform the FUEL SHUTDOWN SOLENOID TEST .
The engine shuts down shortly after starting and trips the battery circuit breaker (CB5).	Try resetting the breaker. If it trips again do not attempt to use the machine. Contact a Lincoln Authorized Field Service Shop.	Repeated tripping and resetting of the circuit breaker can damage it, or alter its trip point. If the breaker has been ripped and reset many times, it should be replaced. Examine the CB5 circuit breaker, run/stop switch. Start button. Shut-down and idle solenoid, engine protection board, fuel gauge and sender, and all the wiring connecting these components. Look for damaged or out of place wiring that may be in contact with other conductors or chassis ground. See wiring diagram . Perform the IDLER SOLENOID TEST . Perform the FUEL SHUTDOWN SOLENOID TEST . The Engine Protection PC Board may be defective.

 **CAUTION**

If for any reason you do not understand the test procedures or are unable to perform the tests/repairs safely, contact the Lincoln Electric Service Department for technical troubleshooting assistance before you proceed. Call 1-888-935-3877.

VANTAGE® 400



Observe Safety Guidelines detailed in the beginning of this manual.

PROBLEMS (SYMPTOMS)	POSSIBLE AREAS OF MISADJUSTMENT(S)	RECOMMENDED COURSE OF ACTION
OUTPUT PROBLEMS		
The engine will not develop full power.	The fuel may be old or contaminated. Supply the engine with clean fresh fuel. The fuel filter may be clogged, replace if necessary. The air filter may be clogged, replace if necessary.	The engine may be in need of adjustment or repair.
The engine will not idle down to low RPM. The machine has normal weld and auxiliary output.	Make sure the idle switch is in the "AUTO IDLE" position. Make sure there is no external load on the weld terminals or the auxiliary power receptacles. Check for mechanical restrictions in the idler solenoid linkage.	Perform the <i>IDLER SOLENOID TEST</i> . Check for damaged wiring or faulty connections at the idle solenoid, the engine protection PC Board, the run/stop switch and the start button. Check for loose or damaged wiring or faulty connections at leads #405 and #226, #227 and connections J,P-55-2 and J,P-55-4, (control PC board P2-5, and engine protection board, J32-2, B3, and J31-8). See <i>wiring diagram</i> . Set idle switch in the "AUTO" position. Set the mode switch to the "CC-STICK" position. Make sure that no load is applied to either the weld or auxiliary output Start the machine and allow it to run for about 30 seconds. Manually move the idle solenoid plunger to the idle position. If the solenoid engages and holds in the idle position, the idle pull coil may be bad.

 **CAUTION**

If for any reason you do not understand the test procedures or are unable to perform the tests/repairs safely, contact the Lincoln Electric Service Department for technical troubleshooting assistance before you proceed. Call 1-888-935-3877.

VANTAGE® 400



Observe Safety Guidelines detailed in the beginning of this manual.

PROBLEMS (SYMPTOMS)	POSSIBLE AREAS OF MISADJUSTMENT(S)	RECOMMENDED COURSE OF ACTION
OUTPUT PROBLEMS		
<p>The engine will not idle down to low RPM. The machine has normal weld and auxiliary output. (continued)</p>		<p>Manually move the idle solenoid plunger to the idle position. If the solenoid engages and holds in the idle position, the idle pull coil may be bad.</p> <p>If the solenoid does not hold in the low idle position, remove plug P6 from the control PC Board and wait about 30 seconds.</p> <p>If the engine drops to low idle check for damage or buildup of conductive material on or around the bypass filter assembly and the output terminals. See wiring diagram.</p> <p>If the engine still does not drop to low idle the control PC Board is probably defective. Replace it. Check that leads #3 and #6 are properly routed through the toroidal current sensor. Each lead must have two turns and must pass through the sensor in the opposite directions. See the wiring diagram. The leads should be wrapped tightly and tie wrapped in place.</p> <p>Check the toroidal current sensor for any signs of damage.</p> <p>Check leads #260 and #261 for poor connections and damage to the conductors and insulation between the toroid current sensor and the P3 connector in the control PC Board.</p> <p>Unplug plug P3 from the control PC Board and check for damaged, dirty, or corroded pins.</p>

 **CAUTION**

If for any reason you do not understand the test procedures or are unable to perform the tests/repairs safely, contact the Lincoln Electric Service Department for technical troubleshooting assistance before you proceed. Call 1-888-935-3877.

Observe Safety Guidelines detailed in the beginning of this manual.

PROBLEMS (SYMPTOMS)	POSSIBLE AREAS OF MISADJUSTMENT(S)	RECOMMENDED COURSE OF ACTION
OUTPUT PROBLEMS		
<p>The engine will not idle down to low RPM. The machine has normal weld and auxiliary output. (continued)</p>		<p>Measure the resistance of toroidal current sensor. Measure between #P-3 and #P-4, the resistance should be 4.1 Ohms. If the sensor is shorted or open replace it. The control board may be bad.</p>
<p>The engine will not go to high idle when using auxiliary power. Auxiliary power is normal when the idler switch is in the "HIGH" idle position, the automatic idle function works properly when welding.</p>	<p>The load on the auxiliary receptacle may be too low. The automatic idle system will not function reliably if the load is less than 100 Watts. The device connected to the auxiliary power may be defective try another device. Make sure the connections to the auxiliary device are tight. Some devices are designed to sense for adequate input power. Product of this type may not turn on due to low voltage and frequency of the idling machine. If this happens the current draw will likely be insufficient to activate the automatic idle system. Device of this type may require that the Idler switch be in the "HIGH IDLE" position.</p>	<p>Check that leads #3 and #6 are properly routed through the toroidal current sensor. Each lead must have two turns and must pass through the sensor in the opposite directions. See wiring diagram. The leads should be wrapped tightly and tie wrapped in place. Check the toroidal current sensor for any signs of damage. Check leads #260 and #261 for poor connections and damage to the conductors and insulation between the toroid current sensor and the P3 connector in the control PC board. Unplug plug P3 from the control PC board and check for damaged, dirty, or corroded pins. Measure the resistance of the toroidal current sensor. Measure between #P-3 and P-4, the resistance should be 10-14 Ohms. If the sensor is shorted or open replace it. The control P.C. Board may be defective.</p>

 **CAUTION**

If for any reason you do not understand the test procedures or are unable to perform the tests/repairs safely, contact the Lincoln Electric Service Department for technical troubleshooting assistance before you proceed. Call 1-888-935-3877.

VANTAGE® 400



Observe Safety Guidelines detailed in the beginning of this manual.

PROBLEMS (SYMPTOMS)	POSSIBLE AREAS OF MISADJUSTMENT(S)	RECOMMENDED COURSE OF ACTION
OUTPUT PROBLEMS		
<p>The engine will not go to high idle when striking arc. The automatic idle system functions normally when using auxiliary power. Welding and auxiliary outputs are normal when the idle switch is in the "HIGH IDLE" position.</p>	<p>Check that the welding cables are in good working condition and the connections are tight. Make sure the work clamp is attached to clean, bare metal.</p>	<p>Check the leads and connections at the SHUNT at the Positive output stud. Check lead 204S and 206S for continuity from the shunt to J-6 on the Weld Control Board. Check the pins and connections at J-6 and J on the Weld Control Board. The weld control P.C. Board may be defective.</p>
<p>The engine will not go to high idle when attempting to strike and arc, or when a load is applied to any of the auxiliary power receptacles.</p>	<p>Check that the welding cables and the auxiliary power lead connections are tight.</p>	<p>The weld control P.C. Board may be defective.</p>
<p>The engine goes to low idle, but will not stay low idle.</p>	<p>Make sure there are no auxiliary loads on either the weld terminals or the auxiliary receptacles. Check that the welding cables and the auxiliary cables and the auxiliary power lead connections are tight and that the insulation is not damaged.</p>	<p>The Idler solenoid linkage may be damaged or out of adjustment. Make sure the solenoid plunger is able to fully ease against the internal stop of the solenoid coil assembly. The low idle RPM may be too low. Perform the ENGINE THROTTLE ADJUSTMENT TEST. The solenoid hold coil power circuit may be defective. Perform the IDLER SOLENOID TEST. The solenoid hold coil power circuit may be faulty. Check wiring and connections on lead #210A and lead #215. The weld control PC Board may be defective.</p>

 **CAUTION**

If for any reason you do not understand the test procedures or are unable to perform the tests/repairs safely, contact the Lincoln Electric Service Department for technical troubleshooting assistance before you proceed. Call 1-888-935-3877.

CASE COVER REMOVAL AND REPLACEMENT PROCEDURE**WARNING**

Service and repair should be performed by only Lincoln Electric factory trained personnel. Unauthorized repairs performed on this equipment may result in danger to the technician or machine operator and will invalidate your factory warranty. For your safety and to avoid electrical shock, please observe all safety notes and precautions detailed throughout this manual.

If for any reason you do not understand the test procedures or are unable to perform the test/repairs safely, contact the Lincoln Electric Service Department for electrical troubleshooting assistance before you proceed. Call 1-888-935-3877.

TEST DESCRIPTION

This procedure will aid the technician in the removal and replacement of the Case Sheet Metal Covers.

MATERIALS NEEDED

- 3/8" Wrench
- 1/2" Wrench

CASE COVER REMOVAL AND REPLACEMENT PROCEDURE (CONTINUED)

FIGURE F.1 – CASE COVER REMOVAL

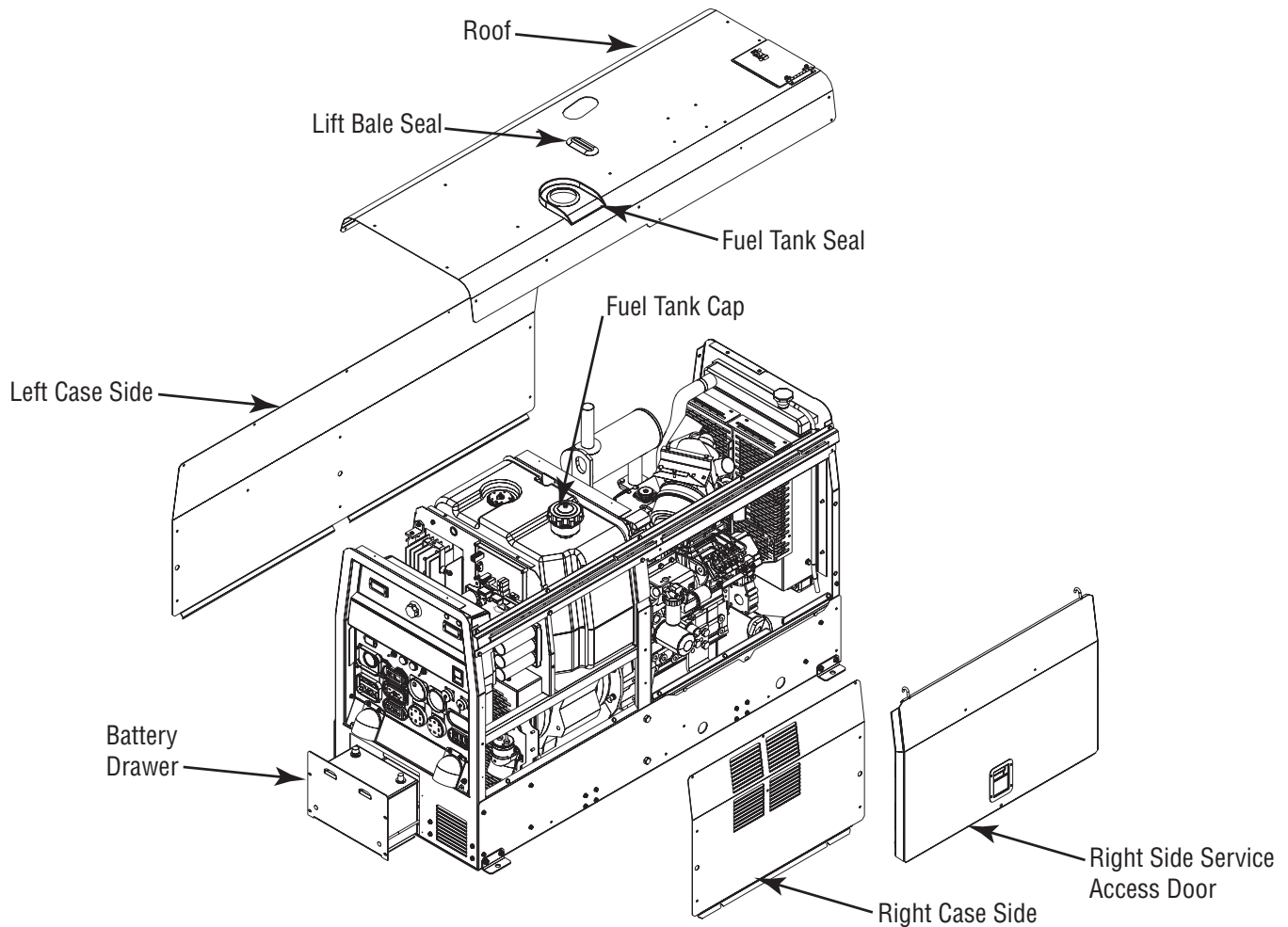

PROCEDURE

1. Turn the engine off.
2. Using the 3/8" wrench, remove the battery cover. Slide the battery out and disconnect the negative battery cable.
3. Unlatch and open the right side service access door. See Figure F.1.
4. Slide the door back 8" to notch in rail. Lift left hinge from track. Slide door forward 2" to notch in rail and lift right hinge from track.
5. Remove access door.
6. With the 1/2" wrench, remove the exhaust pipe rain cap.
7. Remove the fuel tank cap, gasket, and the lift bail cover seal.
8. Remove the screws mounting the roof in place.
9. With the help of an assistant, carefully remove the roof. Replace the fuel cap.
10. With the 3/8" wrench, remove the right case side and the left case side. See Figure F.1.

CASE COVER REMOVAL AND REPLACEMENT PROCEDURE (CONTINUED)**REASSEMBLY PROCEDURE**

1. Install components in reverse order of removal.
2. Be sure components align correctly.
3. Reconnect battery and replace battery door.

CHOPPER MODULE CAPACITOR DISCHARGE PROCEDURE



WARNING

Service and repair should be performed by only Lincoln Electric factory trained personnel. Unauthorized repairs performed on this equipment may result in danger to the technician or machine operator and will invalidate your factory warranty. For your safety and to avoid electrical shock, please observe all safety notes and precautions detailed throughout this manual.

If for any reason you do not understand the test procedures or are unable to perform the test/repairs safely, contact the Lincoln Electric Service Department for electrical troubleshooting assistance before you proceed. Call 1-888-935-3877.

TEST DESCRIPTION

This procedure will insure that the large Capacitors in the Chopper Module have been discharged. This procedure should be performed whenever work is to be attempted on or near the Chopper Module.

MATERIALS NEEDED

Miscellaneous Hand Tools
Volt/Ohmmeter
Resistor (25-1000 ohms and 25 watts minimum) Lincoln part #S10404-114 works well for this purpose
Jumper leads
Wiring Diagram

CHOPPER MODULE CAPACITOR DISCHARGE PROCEDURE (CONTINUED)

FIGURE F.2 - CHOPPER MODULE CAPACITOR TERMINAL DISCHARGE

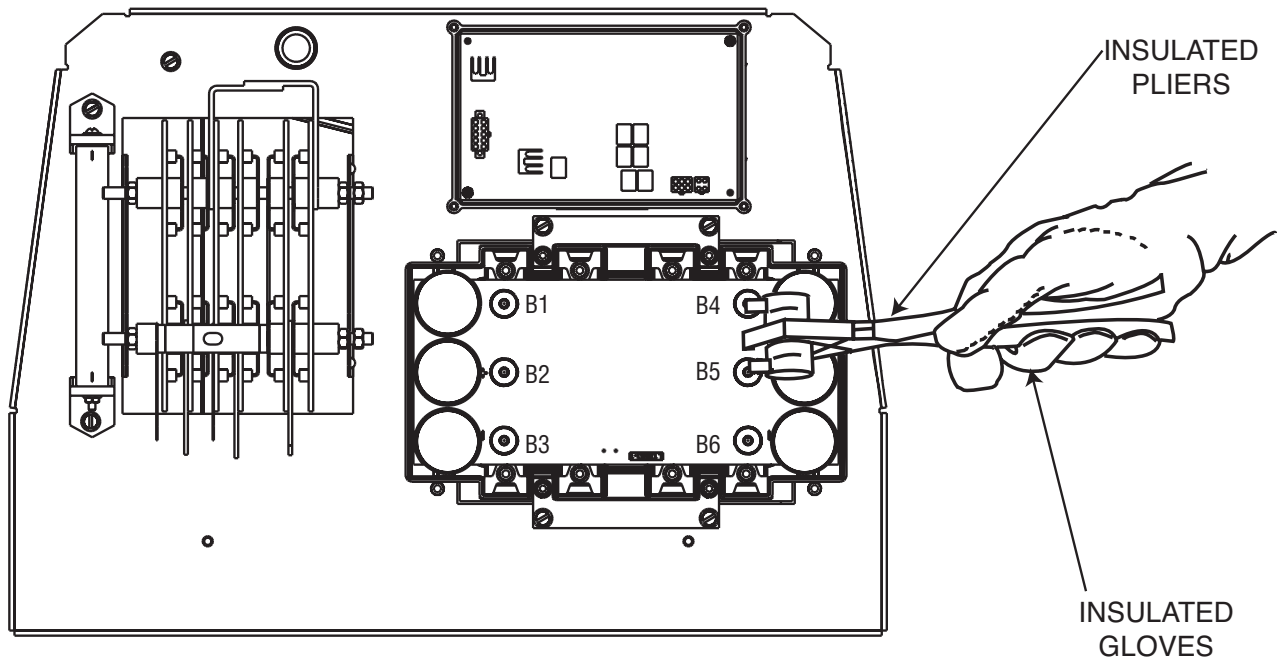

⚠ WARNING

ELECTRIC SHOCK can kill.



- Do not touch electrically hot parts.
- Prior to performing preventative maintenance, perform the following capacitor discharge procedure to avoid electric shock.

DISCHARGE PROCEDURE

1. Turn the engine off.
2. Perform the **Case Cover Removal Procedure**.

NOTE: It is necessary to remove the fuel cap in order to take the case cover off the machine. Be sure the fuel cap is **ON** when discharging the chopper module capacitors.

3. Locate the chopper module and capacitor assembly on the inner machine baffle. See Figure F.2 and the Wiring Diagram.

NEVER USE A SHORTING STRAP TO DISCHARGE CAPACITORS. If the Lincoln recommended resistor, or an equivalent resistor is used, the capacitors can be discharged by holding the resistor with insulated pliers and using the resistor terminals to bridge Chopper Module terminals B1 to B2, and B4 to B5. **DO NOT TOUCH THE TERMINALS OR METAL PARTS OF THE PLIERS WITH YOUR BARE HANDS.** Hold the resistor in place for about 10 seconds.

If another type of resistor is used, jumper leads may need to be attached to the resistor. The leads can then be used to connect terminals B1 to B2, and B4 to B5.

4. Using the volt/ohmmeter, check the voltage across B1 and B2, then B4 and B5. It should be zero volts in both cases.



WARNING

Service and repair should be performed by only Lincoln Electric factory trained personnel. Unauthorized repairs performed on this equipment may result in danger to the technician or machine operator and will invalidate your factory warranty. For your safety and to avoid electrical shock, please observe all safety notes and precautions detailed throughout this manual.

If for any reason you do not understand the test procedures or are unable to perform the test/repairs safely, contact the Lincoln Electric Service Department for electrical troubleshooting assistance before you proceed. Call 1-888-935-3877.

TEST DESCRIPTION

This test will determine if the Shutdown Solenoid resistance values are normal, and also determine if it will function normally when energized with 12 VDC.

MATERIALS NEEDED

Wiring Diagram
Volt/Ohmmeter
Miscellaneous Hand Tools
12 Volt D.C. Power Source, (an automotive battery works well)

FUEL SHUTDOWN SOLENOID TEST (CONTINUED)

FIGURE F.3 - FUEL SHUTDOWN SOLENOID LOCATION

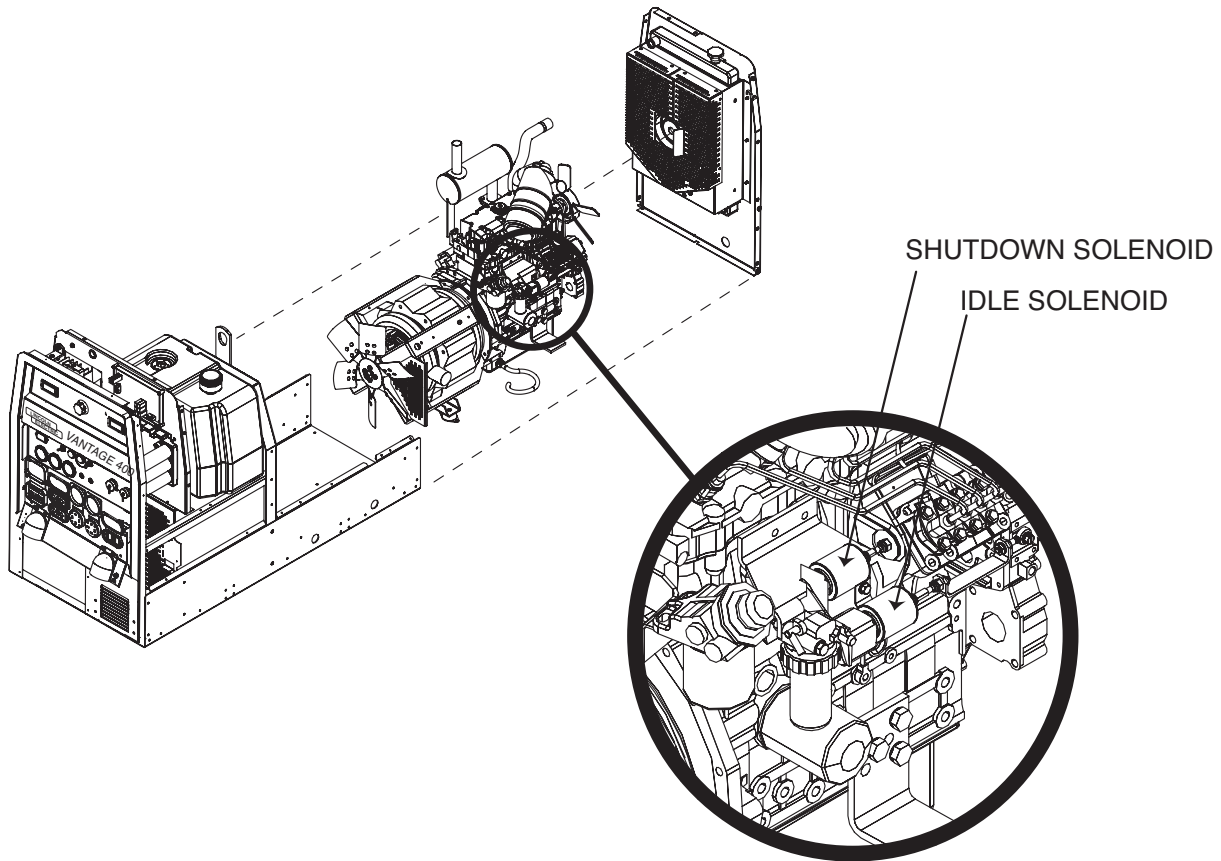

TEST PROCEDURE

1. Turn the engine off.
2. Open the right side engine service access door.
3. Locate the fuel solenoid, located on top of the engine.
4. Locate and unplug harness connection 56. Cut any necessary cable ties. See **Figure F.4**. See Wiring Diagram.
5. Check the coil resistance, (black wire to red wire). The normal resistance is approximately 9 ohms. Check the Resistance between the black wire and a clean, unpainted chassis ground. The resistance should be very high, 500,000 Ohms or more. If any of the above resistance values are incorrect, the solenoid may be faulty. Replace.
6. Using an external 12VDC supply, apply voltage to the coil leads, (black-) to (white+). The solenoid should activate.

If the solenoid does not operate correctly when 12VDC is applied, the solenoid may be defective. Replace.

Re-connect fuel solenoid and replace any previously removed cable ties.
7. If finished testing, close the engine service access doors.

TROUBLESHOOTING & REPAIR

ENGINE THROTTLE ADJUSTMENT TEST



WARNING

Service and repair should be performed by only Lincoln Electric factory trained personnel. Unauthorized repairs performed on this equipment may result in danger to the technician or machine operator and will invalidate your factory warranty. For your safety and to avoid electrical shock, please observe all safety notes and precautions detailed throughout this manual.

If for any reason you do not understand the test procedures or are unable to perform the test/repairs safely, contact the Lincoln Electric Service Department for electrical troubleshooting assistance before you proceed. Call 1-888-935-3877.

TEST DESCRIPTION

If the machine output is low or high, this test will determine whether the Engine is operating at the correct speed (RPM) during both HIGH and LOW idle conditions. You can check RPM using a strobe-tach, a frequency counter, or a vibratach. Directions for adjusting the throttle to the correct RPM are given.

MATERIALS NEEDED

Miscellaneous hand tools and metric wrench set
High visibility marker
Strobe-tach, frequency counter, or vibratach

ENGINE THROTTLE ADJUSTMENT TEST (CONTINUED)

FIGURE F.4 - STROBE MARK LOCATION

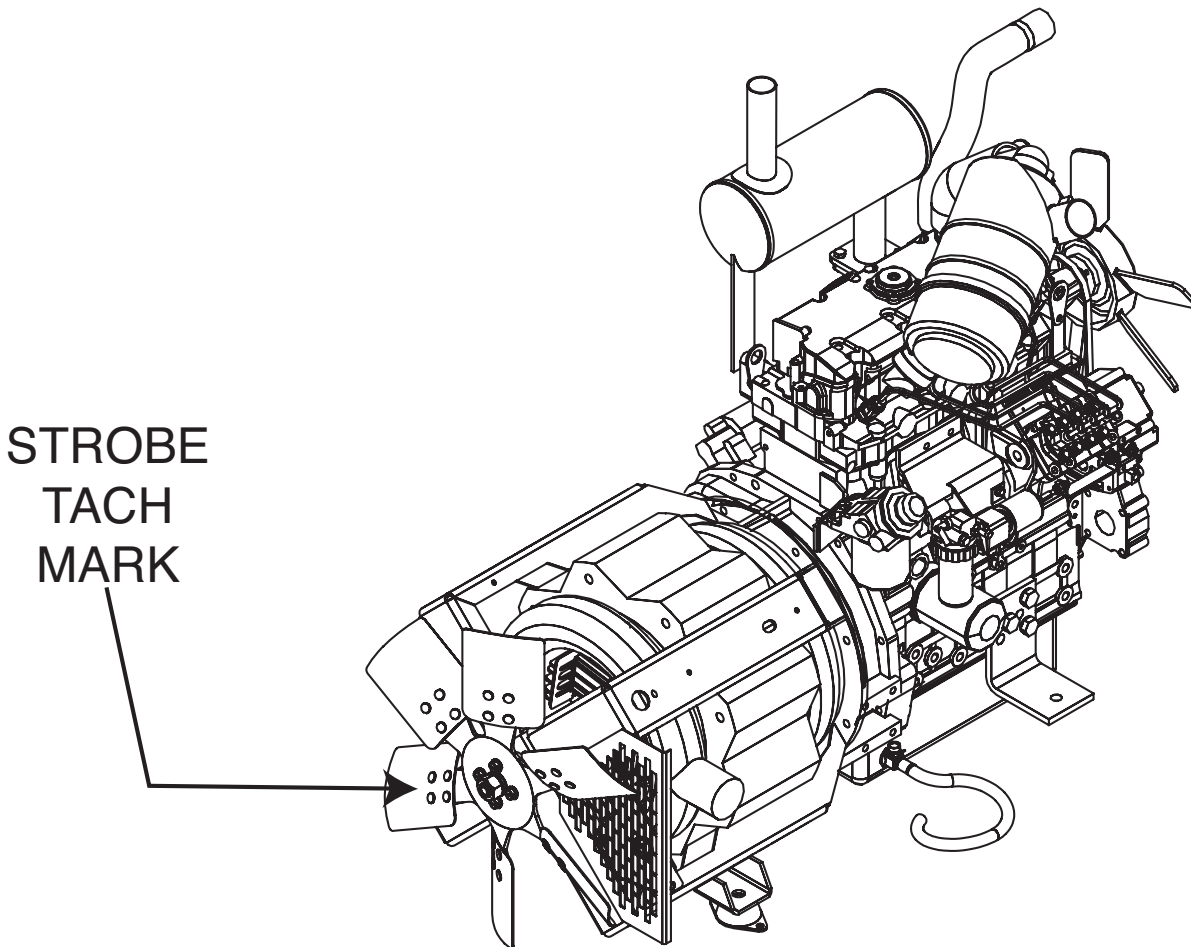

TEST PROCEDURE

Strobe-Tach Method

1. Turn the engine off
2. Open the top and right side engine service access doors.
3. Place a highly visible mark on the engine cooling fan blade. See Figure F.4.
4. Connect the strobe-tach according to the manufacturer's instructions.
5. Start the engine and place the idle switch in the "HIGH IDLE" position. Make sure that there is no load on the machine.
6. Direct the strobe-tach light on the fan blade that had been marked earlier, and synchronize the light with the rotating mark. See the strobe-tach manufacturer instructions.
7. Move the idle switch to the "AUTO IDLE" position and wait for the idle solenoid to energize, and the engine RPM to drop and stabilize at the low idle RPM.
8. Synchronize the strobe-tach to read the low idle RPM.

Low idle speed should be 1300-1400 RPM.

If either of the readings is incorrect, proceed to the **THROTTLE ADJUSTMENT PROCEDURE** later in this section.

The tach should read between 1860 and 1890 RPM.

ENGINE THROTTLE ADJUSTMENT TEST (CONTINUED)

FIGURE F.5 - SOLENOID

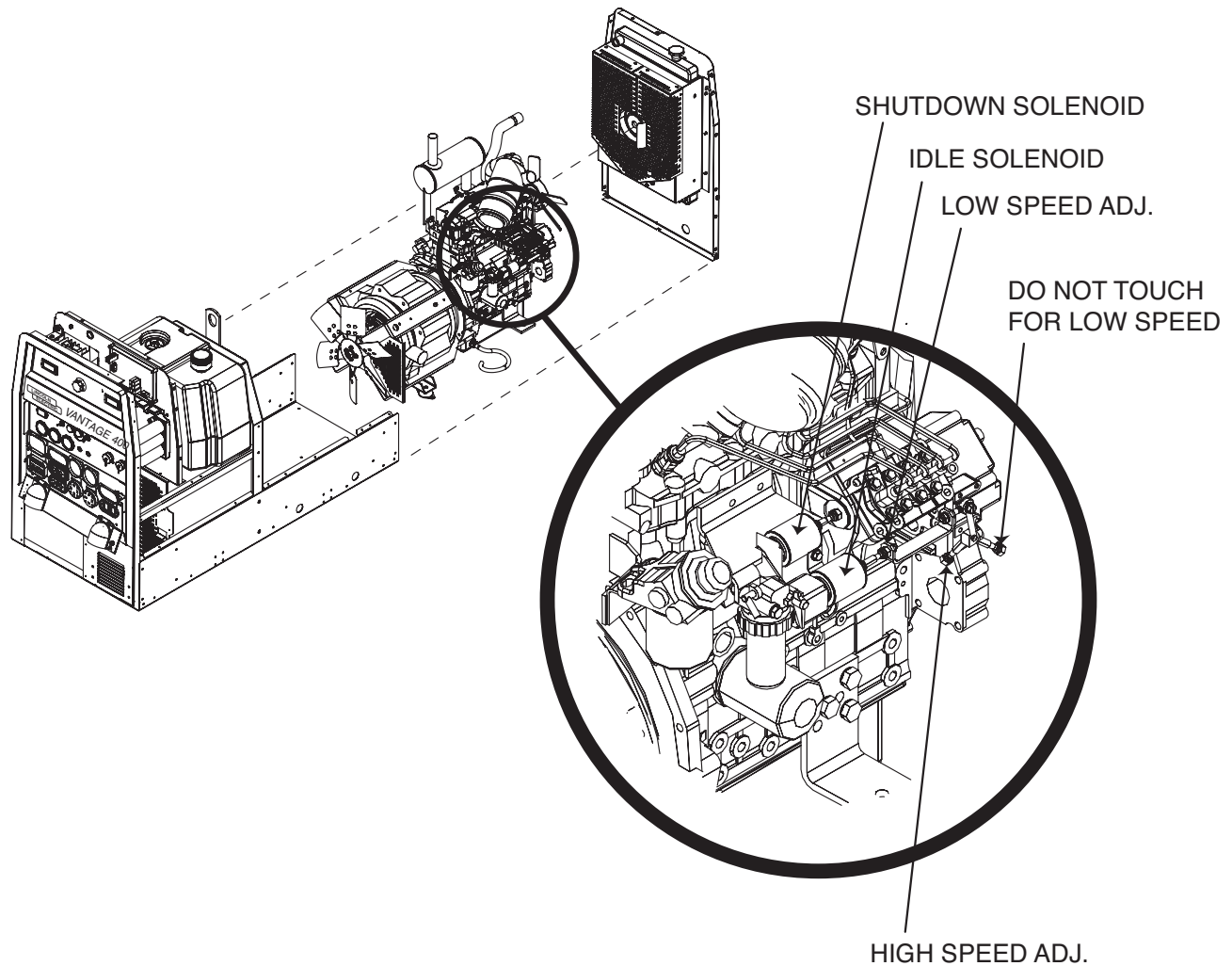
**Frequency Counter Method**

NOTE: A dedicated frequency counter can be used for this test, but many high quality digital multimeters also have this function, and can be easily utilized. See the manufacturer instructions for your frequency counter or multimeter.

1. Set your frequency counter per the meter manufacturer instructions, and plug it into one of the 120VAC auxiliary receptacles.
2. Start the engine and place the idle switch in the "HIGH IDLE" position. Make sure that there is no load on the machine.

The frequency should read between 62.0 and 63.0 Hz.

3. Move the idle switch to the "AUTO IDLE" position and wait for the idle solenoid to energize, and the engine RPM to drop and stabilize at the low idle RPM.

The frequency should read between 43.3 and 46.6 Hz.

If either of the readings is incorrect, proceed to the **THROTTLE ADJUSTMENT PROCEDURE** later in this section.

NOTE: For the VANTAGE® 400, and any other Lincoln Electric 1800 RPM (4 Pole) machine, engine RPM can be determined by multiplying the frequency, in Hz. By 30. (Example: 30 Hz * 62 = 1860RPM)

ENGINE THROTTLE ADJUSTMENT TEST (CONTINUED)

Vibratach Method

A Vibratach is used to measure the vibrations caused by the running engine. It can be positioned anywhere where the engine vibration is reasonably strong. The best results will likely be obtained by opening the top engine cover and placing the Vibratach directly against the top of the engine.

Read and understand the manufacturer's instructions for the Vibratach.

1. Start the engine and place the idle switch in the "HIGH IDLE" position. Make sure that there is no load on the machine.
2. Position and adjust the Vibratach; it should read between 1860 and 1890 RPM.
3. Move the idle switch to the "AUTO IDLE" position and wait for the idle solenoid to energize, and the engine RPM to drop and stabilize at the low idle RPM.
4. Position and adjust the Vibratach; it should read between 1300 and 1400 RPM.

If either of the readings is incorrect, proceed to the "THROTTLE ADJUSTMENT PROCEDURE".

THROTTLE ADJUSTMENT PROCEDURE

IMPORTANT: Both the high and low idle settings are adjusted at the solenoid.

1. Check that the linkage attaching the solenoid to the engine speed control lever is properly aligned and in good condition. It is more important that the solenoid linkage be more precisely aligned when in the high speed (de-energized position).
2. Check to be sure the spring located inside the rubber boot is not broken or missing. In the default, (de-energized) position the spring should be holding the solenoid in the high speed position. See **Figure F.5**.

NOTE: Low idle RPM must be set, and the adjustment nuts tightened, before the high idle RPM is adjusted.

Low Idle adjustment:

1. With engine running and no load applied to the machine, place the idle switch in the "AUTO IDLE" position. Wait for the idle solenoid to energize and the engine speed to drop and stabilize to low idle RPM.
2. If the low idle RPM requires adjustment, loosen the low idle adjustment jam nuts. Turn both nuts so they are clear of the swivel fitting. Rotate the swivel fitting until the engine speed has been set to between 1200 and 1400 RPM. Hold the swivel fitting in position while tightening the first jam nut against the swivel fitting, and then tighten the second jam nut against the first. Do not adjust at engine stop lever.
3. Re-check the low idle RPM, and then proceed to the high idle adjustment.

High idle adjustment:

1. With engine running, place the idle switch in the "HIGH IDLE" position. The solenoid should immediately de-energize, allowing the engine to increase to high idle speed.
2. If the high idle RPM requires adjustment, loosen the high idle adjustment screw jam at engine lever + high speed stop nut and turn the adjusting screw until the engine speed is between 1860 and 1890 RPM. Hold the adjusting screw in position while tightening the jam nut against the solenoid plunger.
3. Re-check the high idle RPM.
4. Close the engine service access doors and shut off the engine.

IDLER SOLENOID TEST**WARNING**

Service and repair should be performed by only Lincoln Electric factory trained personnel. Unauthorized repairs performed on this equipment may result in danger to the technician or machine operator and will invalidate your factory warranty. For your safety and to avoid electrical shock, please observe all safety notes and precautions detailed throughout this manual.

If for any reason you do not understand the test procedures or are unable to perform the test/repairs safely, contact the Lincoln Electric Service Department for electrical troubleshooting assistance before you proceed. Call 1-888-935-3877.

TEST DESCRIPTION

This test will determine if the Idler Solenoid resistance values are normal, and also determine if it will function normally when it is energized with 12VDC.

MATERIALS NEEDED

Miscellaneous Hand Tools
External 12VDC Supply (30 amps) (automotive battery works well)
Wiring Diagram
Volt/Ohmmeter

FIGURE F.6 - PLUG(S) PIN LOCATION

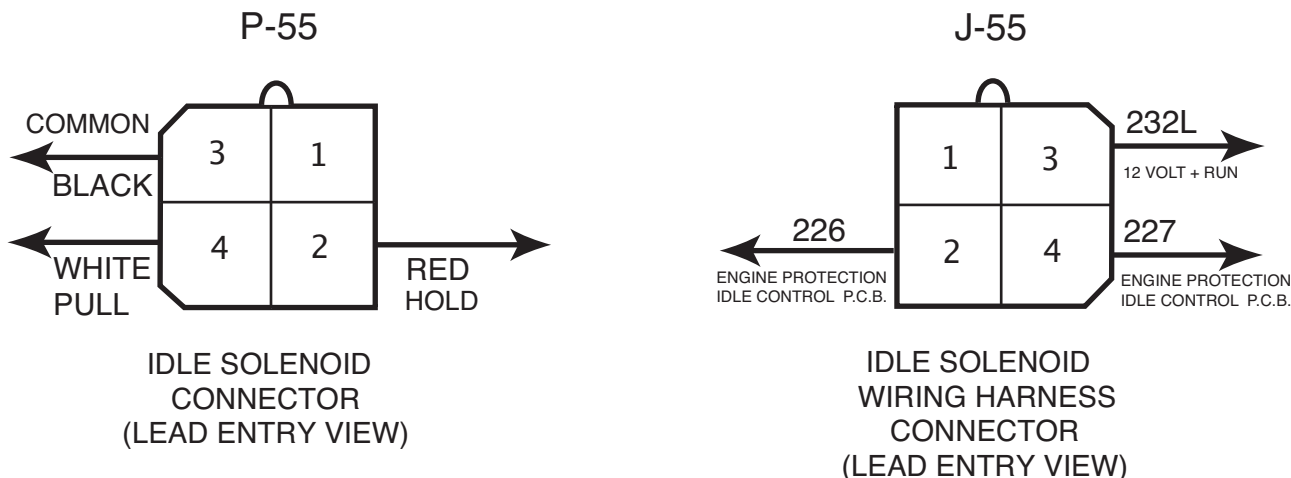

TEST PROCEDURE

1. Turn the engine off.
2. Open the right side engine service access door.
3. Locate the idler solenoid mounted right side of engine.
4. Locate and unplug harness connection P-55. Cut any necessary cable ties. See Wiring Diagram.
5. Using the volt/ohmmeter, check the pull-in coil resistance, pins 3 and 4 (black wire to white wire). The normal resistance is less than 0.2 ohms. Check the hold-in coil resistance, pins 3 and 2 (black wire to red wire). The normal resistance is approximately 11 ohms. Check the resistance between pin 3 (black wire) and a clean, unpainted chassis ground. The resistance should be very high. 500,000 Ohms or more. If any of the above resistance values are incorrect, the solenoid may be faulty. Replace. See Figure F.6.
6. Using the external 12VDC supply, apply 12VDC to the pull-in coil leads at pins 3+ and 4- (black wire to white wire). The solenoid should activate. REMOVE THE VOLTAGE IMMEDIATELY to avoid damage to the unit.

Apply 12VDC to the hold-in coil at pin #3 (black wire +) and pin #2 (red wire -). While the voltage is applied, manually move the solenoid to the low idle position. The solenoid plunger should hold this position until the voltage is removed. See Figure F.6.
7. If either coil does not operate as described, check for mechanical restrictions or other problems with the linkage.
8. If the linkage is intact and the solenoid does not operate correctly when the 12VDC is applied, the solenoid may be faulty. Replace.
9. Re-connect idle solenoid and replace any previously removed cable ties.
10. If finished testing, close the engine service access door.

ENGINE ALTERNATOR TEST**WARNING**

Service and repair should be performed by only Lincoln Electric factory trained personnel. Unauthorized repairs performed on this equipment may result in danger to the technician or machine operator and will invalidate your factory warranty. For your safety and to avoid electrical shock, please observe all safety notes and precautions detailed throughout this manual.

If for any reason you do not understand the test procedures or are unable to perform the test/repairs safely, contact the Lincoln Electric Service Department for electrical troubleshooting assistance before you proceed. Call 1-888-935-3877.

TEST DESCRIPTION

This test will determine if the Engine Alternator is properly charging the battery.

MATERIALS NEEDED

Miscellaneous Hand Tools
Volt Meter
Wiring Diagram

FIGURE F.7 - LEAD LOCATIONS

BACK OF ALTERNATOR

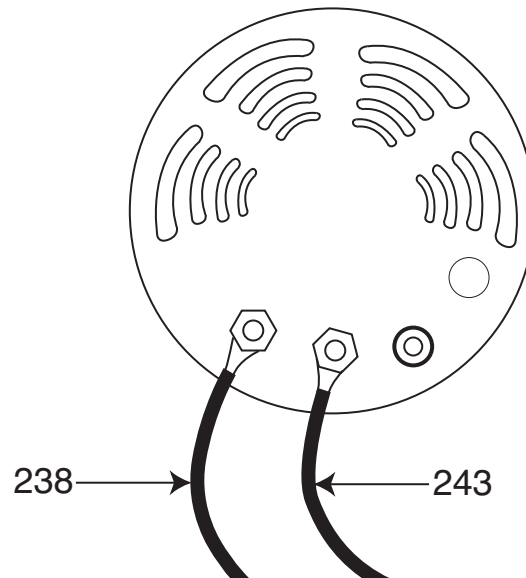

TEST PROCEDURE

1. Turn the engine off.
2. Open the engine access door and check the voltage at the battery terminals. It should be approximately 12 volts DC.
3. Attach the meter leads to the battery terminals, being careful to position them so they stay clear of moving parts while the engine is running.
4. Place the idle switch in the "HIGH IDLE" position, start the engine, and allow it to run at high idle speed for about 15 to 30 seconds.
5. The meter should read about 13.7 to 14.2 VDC.
6. If the meter reads correctly the engine alternator is producing adequate power to charge the battery and this test is complete.
7. If the voltage is significantly higher than the above values, the alternator is not properly regulating the battery charging voltage and should be replaced. If the voltage reads the same or less than the measurement taken when the engine was not running, proceed with the following tests.
8. Turn off the engine, disconnect the meter from the battery, and open the engine access door on the left side of the machine.
9. Make sure the idle switch is still in the "high" position, start the engine, and allow it to run at high idle speed for about 15 to 30 seconds.
10. Place the negative meter probe on a good chassis ground, or the negative battery terminal. Place the positive meter probe on the battery terminal on the back of the alternator. (Lead #238) See Figure F.7. See Wiring Diagram.
11. The meter should read about 13.7 to 14.2 VDC.
12. Move the positive probe to the DT terminal on the back of the alternator. (Lead 243C) See Figure F7.
13. The meter should read about 13.7 to 14.2 VDC.
14. If the meter reads correctly, check the connections between the alternator and the battery. See wiring diagram.
15. If the voltage at both of the above test points reads the same or less than the battery voltage measurement taken when the engine was not running, the alternator is defective. Repair or replace it.

TROUBLESHOOTING & REPAIR

BRUSH AND SLIP RING SERVICE PROCEDURE



WARNING

Service and repair should be performed by only Lincoln Electric factory trained personnel. Unauthorized repairs performed on this equipment may result in danger to the technician or machine operator and will invalidate your factory warranty. For your safety and to avoid electrical shock, please observe all safety notes and precautions detailed throughout this manual.

If for any reason you do not understand the test procedures or are unable to perform the test/repairs safely, contact the Lincoln Electric Service Department for electrical troubleshooting assistance before you proceed. Call 1-888-935-3877.

DESCRIPTION

This procedure provides guidance in testing and maintaining the Brush and Slip Ring System.

MATERIALS NEEDED

- Volt/Ohmmeter
- Miscellaneous Hand Tools
- 500 or 600 grit emery cloth
- 180 grit sand paper

BRUSH AND SLIP RING SERVICE PROCEDURE (CONTINUED)

FIGURE F.8 – BRUSH & SLIP RING LOCATIONS

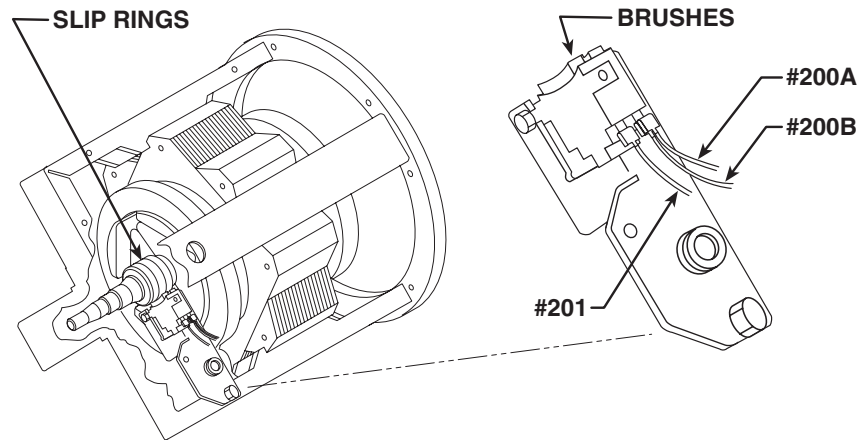

TEST PROCEDURE

1. Perform the **Case Cover Removal Procedure**.
2. Examine brushes and slip rings. The slip rings, brush holder, and brushes should be clean and free from oil or grease. The brushes should be making good, continuous contact with the slip rings.
3. The brushes should be of sufficient length and have adequate spring tension. Generally, the brushes should be replaced if either brush has less than 1/4" remaining before it reaches the end of its travel. Spring tension should be sufficient to hold the brushes firmly against the slip rings.
4. The brushes should be removed from the brush holder and examined. The terminals should be clean. The shunt, (braided lead connecting the carbon brush to the terminal) should be in good condition and firmly connected to the carbon brush and to the connection terminal.
5. If the slip rings are discolored, display evidence of excessive sparking, or the brushes have worn prematurely; these may be signs of a grounded or shorted rotor. Perform the **Rotor Resistance Test**.
6. Check for evidence of sticking brushes. Sticking brushes will normally result in the slip rings being pitted and discolored from excessive arcing. Another sign of sticking brushes is instability or loss of both weld and auxiliary output, but the machine may begin to work properly, for a short time, after being jarred or moved.
7. If there is any evidence that the brushes may have been sticking in the brush holders, a new brush holder and brush assembly should be installed.

Cleaning slip rings:

1. In the event that the slip rings have become dirty, discolored or mildly pitted, it will be necessary to clean them, using very fine, 500 or 600 grit sand paper or a 220 or 320 grit commutator stone.

Seating Brushes:

1. If brushes have been replaced, repositioned, or are not making full contact with the slip rings, it may be necessary to re-seat them. This can be done by placing a strip of 180 grit sandpaper between the slip rings and the brushes, with the abrasive side against the brushes. Pull the sandpaper strip around the circumference of the slip rings in the direction of rotor rotation only. Repeat this procedure until the surface of each brush is in full contact with its matching slip ring.
2. Use a low pressure compressed air to thoroughly blow the carbon, commutator stone, and sandpaper dust from the machine before operating.
3. Perform the **Case Cover Replacement Procedure**

NOTE: See Figure F.8 for general locations.

ROTOR RESISTANCE AND GROUND TEST (STATIC)**WARNING**

Service and repair should be performed by only Lincoln Electric factory trained personnel. Unauthorized repairs performed on this equipment may result in danger to the technician or machine operator and will invalidate your factory warranty. For your safety and to avoid electrical shock, please observe all safety notes and precautions detailed throughout this manual.

If for any reason you do not understand the test procedures or are unable to perform the test/repairs safely, contact the Lincoln Electric Service Department for electrical troubleshooting assistance before you proceed. Call 1-888-935-3877.

TEST DESCRIPTION

This test will determine if the Rotor Winding is open, shorted, or grounded.

MATERIALS NEEDED

Miscellaneous Hand Tools
Ohmmeter Analog type meter required for dynamic resistance test.)
Wiring Diagram

ROTOR RESISTANCE AND GROUND TEST (STATIC) (CONTINUED)

FIGURE F.9 - ROTOR BRUSH LEADS

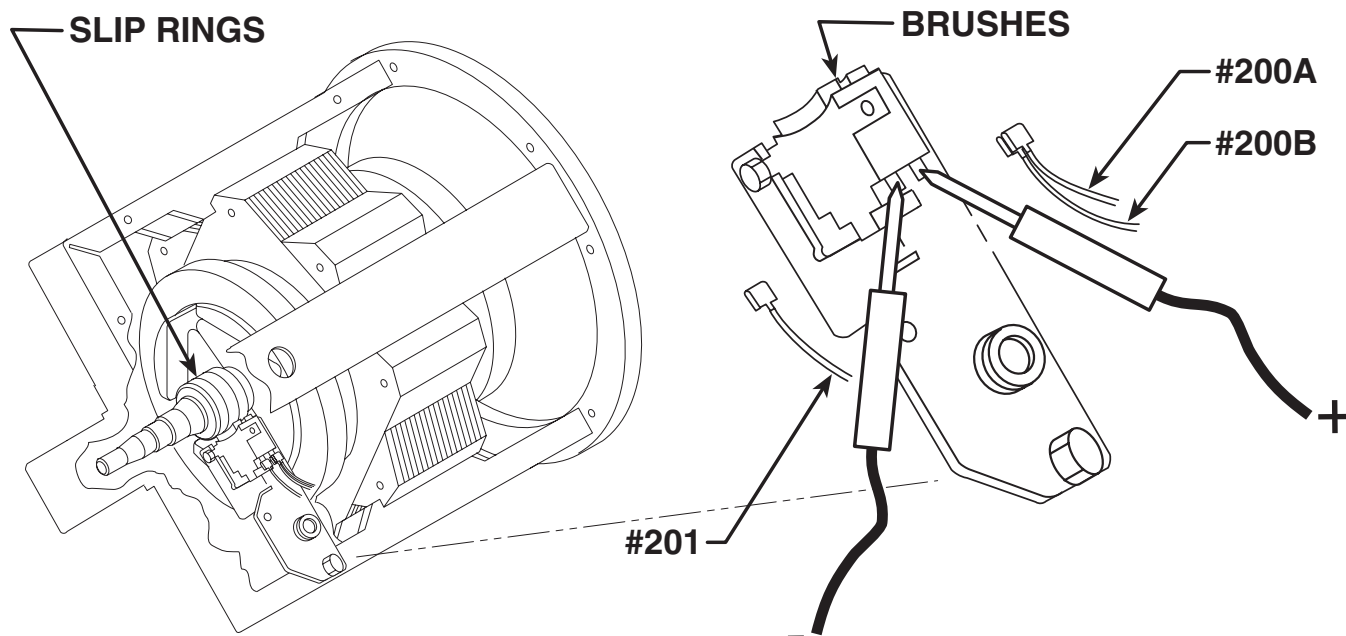

TEST PROCEDURE

1. Turn the engine off.
2. Perform the **Case Cover Removal Procedure**.
3. Locate and label the leads from the rotor brush holder assembly. See Figure F.9. Using the needle nose pliers, remove the leads. This will electrically isolate the rotor windings.
4. Using the ohmmeter, check the rotor winding resistance across the slip rings. See Figure F.9. Normal resistance is approximately 25 ohm, at 77° F. (25° C.).
5. Measure the resistance to ground. Place one meter probe on either of the slip rings. Place the other probe on any good unpainted chassis ground. The resistance should be very high, at least 500,000 (500k) ohms.
6. If the test does not meet the resistance specifications, then the rotor may be faulty and should be replaced.
7. If this test meets the resistance specifications, continue testing using the dynamic rotor resistance and ground test.

ROTOR RESISTANCE AND GROUND TEST (DYNAMIC) (Also referred to as flying resistance test)



WARNING

Service and repair should be performed by only Lincoln Electric factory trained personnel. Unauthorized repairs performed on this equipment may result in danger to the technician or machine operator and will invalidate your factory warranty. For your safety and to avoid electrical shock, please observe all safety notes and precautions detailed throughout this manual.

If for any reason you do not understand the test procedures or are unable to perform the test/repairs safely, contact the Lincoln Electric Service Department for electrical troubleshooting assistance before you proceed. Call 1-888-935-3877.

DESCRIPTION

This test checks for faults in the Rotor Winding, while these windings are being stressed by the mechanical forces encountered during normal operation.

MATERIALS NEEDED

Miscellaneous Hand Tools
Ohmmeter (Analog type meter required for dynamic resistance test.)
Wiring Diagram

NOTE: This test is best performed with a good quality analog type ohmmeter. Many digital meters will not provide stable or accurate Resistance readings while the rotor is spinning.

ROTOR RESISTANCE AND GROUND TEST (DYNAMIC) (CONTINUED)**TEST PROCEDURE**

This test requires that the brushes and slip rings are clean, in good condition, and are properly seated.

1. Perform the **Brush and Slip Ring Service Procedure** if necessary.
2. Insulate the lead wires that had been disconnected from the brushes during the static rotor resistance test. Position and secure them so they cannot become damaged by the spinning rotor.
3. Securely attach the ohmmeter leads to the brush terminals. Use clips or terminals to attach the leads BEFORE starting the engine.
4. Start the engine and run it at high idle speed (1860-1890 RPM). The resistance should read approximately 25Ω at 77°F (25°C .)
4. Shut off engine, and move one of the ohmmeter leads to a good clean chassis ground.
5. Restart the engine and run it at high idle speed (1860-1890 RPM). The resistance should be very high, at least 500,000 (500k) ohms.
6. If the resistance readings differ significantly from the values indicated, re-check the brushes and the brush spring tension. If the brushes and slip rings are good, replace the rotor.
7. If all testing is finished, perform the **Case Cover Replacement** procedure.

***NOTE:** The resistance of the windings will change with temperature. Higher temperatures will produce higher resistance, and lower temperatures will produce lower resistance.

ROTOR VOLTAGE TEST**WARNING**

Service and repair should be performed by only Lincoln Electric factory trained personnel. Unauthorized repairs performed on this equipment may result in danger to the technician or machine operator and will invalidate your factory warranty. For your safety and to avoid electrical shock, please observe all safety notes and precautions detailed throughout this manual.

If for any reason you do not understand the test procedures or are unable to perform the test/repairs safely, contact the Lincoln Electric Service Department for electrical troubleshooting assistance before you proceed. Call 1-888-935-3877.

TEST DESCRIPTION

This test will determine if the Rotor Winding is operating at normal charge.

MATERIALS NEEDED

Miscellaneous Hand Tools
Voltmeter
Wiring Diagram

FIGURE F.10 - LEAD LOCATIONS

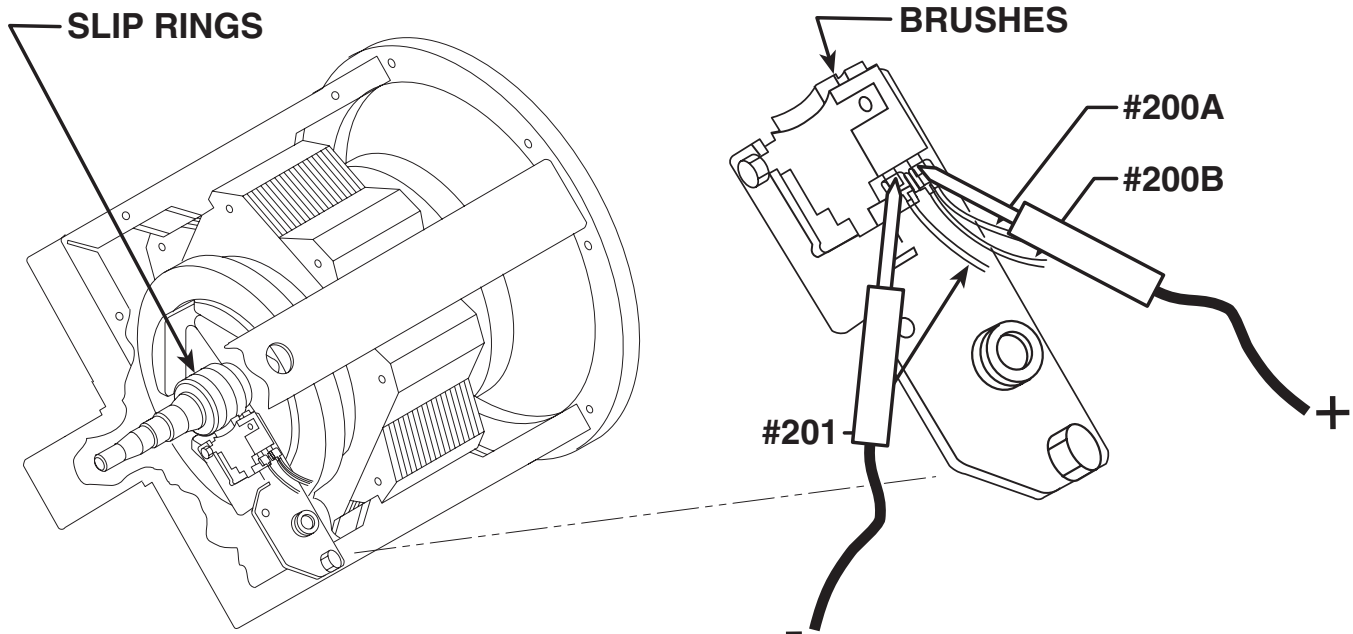

TEST PROCEDURE

1. Perform the **Case Cover Removal Procedure**.
2. Connect the voltmeter probes to the brush terminals. See Figure F.10. See the wiring diagram.
3. Set the RUN/STOP switch to "RUN" and the IDLE switch to "HIGH". Start the engine and allow the RPM to stabilize for about 15 to 30 seconds.
The meter should read 145 to 175 VDC.
4. Set the RUN/STOP switch to "STOP"
5. If the meter reading is normal, this test is complete.
6. If the voltage measures zero or very near zero, the rotor flashing circuit may be faulty or the rotor may be shorted.
7. Perform the **Rotor Resistance and Ground Test** and the **Flashing Voltage Test**.
8. **If voltage is higher than 175 VDC**, the engine RPM may be too high, or there may be voltage intrusion from one of the higher voltage stator windings to the stator exciter winding. Perform the **Engine Throttle Adjustment Test**, and the **Stator Short Circuit and Ground Test**.
9. **If the voltage is lower than 145, but higher than 120**, the engine RPM may be too low, or there may be problems in the windings or other exciter circuit components or connections. Perform the **Engine Throttle Adjustment Test**, and then perform the testing described below, under the heading **"If the voltage measures about 3 to 5 VDC"**.

10. If the meter reading indicates **battery voltage, about 12 to 14 VDC**, the rotor may be open, or the brushes may be faulty or not making proper contact with the slip rings. Perform the **Rotor Resistance Test**, and **Brush and Slip Ring Service Procedure**.
11. If the voltage measures about **3 to 5 VDC**, the generator is not building-up to normal output even though the flashing circuit appears to be functioning normally. This condition could be caused by one of several failed components or connections. Continue with the following test.
12. Check the field bridge rectifier, and capacitor; also check the wiring and terminals connecting them. See the wiring diagram.
13. Perform the **Rotor Resistance Test**.
14. Perform the **Stator Short Circuit and Ground Test**.
15. When the Stator short circuit and ground test has been completed, reconnect leads 6 and 5H to the field bridge rectifier, (D3). All other stator leads should remain disconnected and isolated at this time.
16. Be sure that there are no leads of any kind across any of the stator windings, except the 6A - 5H winding. Examine stator wiring for damage, pinched leads, chafed insulation, etc. If necessary, disconnect and isolate the stator output leads as close to the starter as possible. See wiring diagram.
17. All of these disconnected leads should be insulated, and/or positioned so they cannot come in contact with any other wiring or chassis ground and cannot be damaged by moving parts when the engine is running.
18. Re-start the machine and measure the rotor voltage.
19. If rotor voltage continues to read significantly lower than 120 VDC, the Stator is probably defective and should be replaced.

NOTE: The field bridge rectifier and field capacitor may appear to function normally when tested independently, but may malfunction when placed under the stress or normal operation. For this reason, It is recommended that the bridge rectifier and the capacitor be replaced with known good components before replacing the stator.

FLASHING VOLTAGE TEST (Engine Not Running)



WARNING

Service and repair should be performed by only Lincoln Electric factory trained personnel. Unauthorized repairs performed on this equipment may result in danger to the technician or machine operator and will invalidate your factory warranty. For your safety and to avoid electrical shock, please observe all safety notes and precautions detailed throughout this manual.

If for any reason you do not understand the test procedures or are unable to perform the test/repairs safely, contact the Lincoln Electric Service Department for electrical troubleshooting assistance before you proceed. Call 1-888-935-3877.

TEST DESCRIPTION

This test checks the flashing voltage with the Engine stopped, by simulating a running condition.

MATERIALS NEEDED

Miscellaneous Hand Tools
Voltmeter
Wiring Diagram

FLASHING VOLTAGE TEST (CONTINUED)

TEST PROCEDURE

1. Perform the **Case Cover Removal Procedure**.
2. Make sure that the battery is fully charged and in good condition, and the battery connections are clean and tight.
3. Remove leads 234 and 235 from the oil pressure switch. Insulate or position the lead so it cannot come in contact with chassis ground or any other wiring. See Wiring Diagram.

NOTE: Disconnecting leads 234 and 235 bypass the oil-pressure switch and simulates a running engine.

4. Place the RUN/STOP switch in the "RUN" position. (The engine protection light should remain off.)
5. Connect the voltmeter probes to brush terminals.
6. Measure the voltage; it should read about 3 to 5 VDC.
7. Set the RUN/STOP switch to the "STOP" position.
8. If the meter reads normal voltage of 3 to 5 VDC, this test is complete.
9. If the meter reading indicates battery voltage, about 12 to 14 VDC, The rotor may be open, or the brushes may be faulty or not making proper contact with the slip rings.
10. Perform the **Rotor Resistance Test**. Perform the **Brush and Slip Ring Service Procedure**.
11. If the voltage measures zero or very near zero; this condition could be caused by a poor connection or a defective component in the flashing circuit, or a shorted rotor winding.
12. Perform the **Rotor Resistance Test**.

13. Refer to the wiring diagram, pull plug P-31 from the Idle Control board and inspect each terminal. Make sure that all terminals both on the board and in the plug are clean and in good condition, and that the pins are securely crimped to the flex leads. Perform the following additional test.

14. Switch the RUN/STOP switch to the "RUN" position.

15. Use a voltmeter to check for the presents of about 12VDC, battery voltage, at the following locations on the engine protection/ idle control p.c.b.

(-) Lead #5S (B1) to (+) Lead #232 (J31-1)

(-) Lead #5S (B1) to (+) Lead #232F (J31-2)

(-) Lead #5S (B1) to (+) Lead #200 (J33-5)

NOTE: Lead #232 supplies 12VDC battery voltage to the engine protection PC board whenever the run/stop switch is in the run position.

Lead #200 supplies DC flashing voltage from the control PC board to the positive slip ring through.

16. If battery voltage is present at all of the above points; check the top grounding stud on inside left case from and lead #5H, also check leads #200, #200B, R3. Make sure all terminals are crimped tightly to the flex leads and arc free of corrosion.

FLASHING VOLTAGE TEST (CONTINUED)

17. If battery voltage is present at leads #232 and #232F, but not present at leads #200 The engine protection / idle P.C.B. board is probably defective. Replace.
18. If battery voltage is present at lead #232, but not present at leads #232F or #200 check the engine protection wiring per the wiring diagram.
19. If battery voltage is not present at lead #232, check wiring per wiring diagram, and check the run/stop switch. Also check the ground PC board chassis ground wire, lead #5K and the stud where it connects to the chassis.
20. Set the RUN/STOP switch to the "STOP" position.
21. Re-connect lead #234 to the oil pressure switch.
22. If testing is completed, perform the **Case Cover Replacement Procedure**.

STATOR VOLTAGE TESTS**WARNING**

Service and repair should be performed by only Lincoln Electric factory trained personnel. Unauthorized repairs performed on this equipment may result in danger to the technician or machine operator and will invalidate your factory warranty. For your safety and to avoid electrical shock, please observe all safety notes and precautions detailed throughout this manual.

If for any reason you do not understand the test procedures or are unable to perform the test/repairs safely, contact the Lincoln Electric Service Department for electrical troubleshooting assistance before you proceed. Call 1-888-935-3877.

TEST DESCRIPTION

This test will determine if the Stator is able to produce correct voltage from of its Windings. It will only yield meaning data if the engine high idle speed is correct, (1860 to 1890 RPM), and approximately 160 VDC is present across the Rotor Slip Rings.

NOTE: The Slip Ring voltage will most likely be correct if at least one of the AC output voltages is correct.

MATERIALS NEEDED

Miscellaneous Hand Tools
Voltmeter
Test pins

FIGURE F.11 RECEPTACLE LEAD LOCATIONS (TYPICAL)

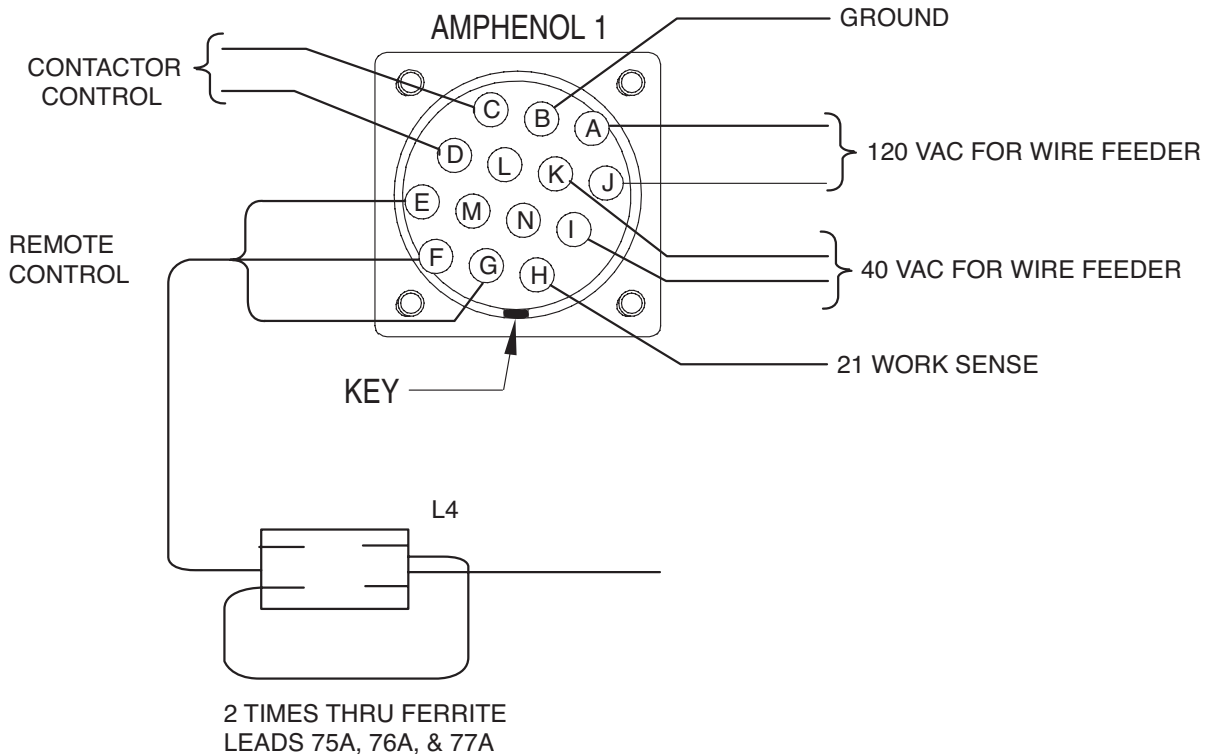

TEST PROCEDURE

1. Perform the **Case Cover Removal Procedure**.

NOTE: Voltage tests of the 120 and 120/240 VAC receptacles can be performed by placing the meter probes directly into the appropriate connection slots in the front of the receptacles rather than testing at the lead connections described below. If the meter probes are not long enough to make contact with the conductors inside the receptacles, test pins may be used.

To test the 120 VAC auxiliary winding:

1. Connect the volt/ohmmeter probes to either 120 VAC receptacle as follows.
2. For the upper receptacle, place the probes directly into receptacle, or connect to leads #3D and #5A. See Figure F.11. See wiring diagram.

For the lower receptacle, place the probes directly into the receptacle, or connect to leads #6E and 5B. See Figure F.11. See wiring diagram.

3. Start the engine and run it at high idle (1860-1890 RPM).
4. Check the AC voltage reading. It should read between 115 and 132 VAC.

To test the 240 VAC auxiliary winding:

1. Connect the meter probes to leads #6F and #3E where they connect to the 120/240VAC receptacle, or insert the probes into the 240 VAC connection slots in the front of the receptacle. See Figure F.11. See wiring diagram.
2. Start the engine and run it at high idle (1860-1890 RPM).
3. Check the AC voltage reading. It should read between 230 and 264 VAC.
4. If these voltage readings are not within the specified limits, check for tripped or defective circuit breakers, loose connections, or broken wires between the test points and the stator windings. If there are no wiring problems, and the circuit breakers are not tripped or defective, the stator is defective and should be replaced.

FIGURE F.12 - RECTIFIER BRIDGE DETAIL

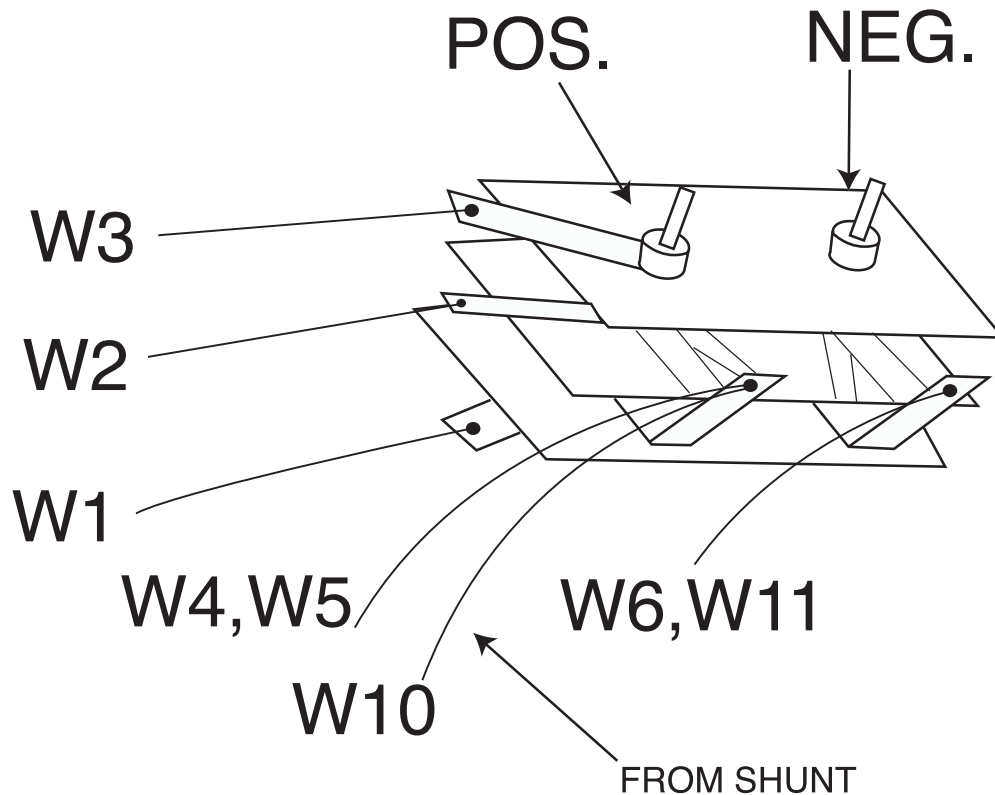

To test the 120 VAC wire feeder supply:

NOTE: The wire feeder AC voltage supply tests require that the meter probes be inserted into the Amphenol connection cavities. Care should be taken to avoid damaging or expanding the terminals when inserting the probes.

NOTE: The 120 VAC power supplied to the 14 pin Amphenol connector originates from the same winding that supplies the 120 VAC receptacles. If the machine has previously passed 120VAC auxiliary winding test, this test can only reveal problems in connections or components between the Amphenol and the stator winding.

1. Connect the voltmeter probes to pins "A" (lead #32) and "J" (lead #31) of the 14 pin Amphenol. See figure #3 and wiring diagram.
2. Start the engine and run it at high idle (1860 to 1890 RPM).
3. The AC voltage reading should be between 115 and 132 VAC.
4. If these voltage readings are not within specifications, check for a tripped or defective circuit breaker, faulty connections, or broken wires between the test points and the stator windings. See wiring diagram.

STATOR VOLTAGE TESTS (CONTINUED)**To test the 42 VAC wire feeder winding:**

1. Connect the voltmeter probes to pins "I" (lead 41A) and "K" (lead #42A) of the 14 pin Amphenol. See **Figure F.11**.
2. Start the engine and run it at high idle (1860 to 1890 RPM).
3. The AC voltage reading should be between 40 and 50 VAC.
4. If these voltage readings are not within the specified limits, check for a tripped or defective circuit breakers, loose connections, or broken wires between the test points and the stator windings. If there are no wiring problems, and the circuit breakers are not tripped or defective, the stator is defective and should be replaced.

To test the three-phase weld winding:

1. Locate weld winding leads W1/W6, W2/W3, and W4/5 where they connect to the three-phase output bridge rectifier. See **Figure F.12**. See wiring diagram.
2. Start the engine and run it at high idle (1860 to 1890 RPM).
3. Check for about 60 to 65 VAC from leads W1/W6, W2/W3, and W4/5.
4. If these voltage readings are not within the specified limits, check for loose connections or broken wires between the test points and the stator windings. If there are no wiring problems, the stator is defective and should be replaced.

* These values are maximum for a cold machine.

TROUBLESHOOTING & REPAIR

STATOR SHORT CIRCUIT & GROUND TEST



WARNING

Service and repair should be performed by only Lincoln Electric factory trained personnel. Unauthorized repairs performed on this equipment may result in danger to the technician or machine operator and will invalidate your factory warranty. For your safety and to avoid electrical shock, please observe all safety notes and precautions detailed throughout this manual.

If for any reason you do not understand the test procedures or are unable to perform the test/repairs safely, contact the Lincoln Electric Service Department for electrical troubleshooting assistance before you proceed. Call 1-888-935-3877.

TEST DESCRIPTION

This test will determine if there are undesirable electrical connections between the Stator Windings and chassis ground, or between individual Windings within the Stator.

This test should be performed if flashing voltage is present at the Rotor Slip Rings, Rotor resistance, Field Bridge Rectifier, Field Capacitor and all associated wiring are proven to be good, but the Stator output voltage fails to build-up to normal levels, or is too high in one or more, but not all, of the Windings.

MATERIALS NEEDED

Miscellaneous Hand Tools
Ohm Meter

STATOR SHORT CIRCUIT & GROUND TEST (CONTINUED)

FIGURE F.13 - WELD CONTROL BOARD

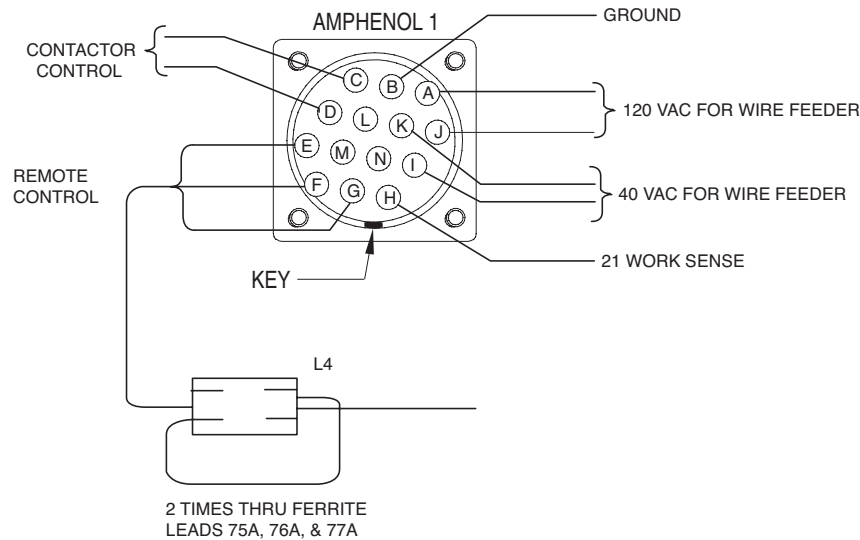

TEST PROCEDURE

1. Perform **Case Cover Removal Procedure**.
2. Perform **Capacitor Discharge Procedure**.
3. Unplug anything that may be connected to the auxiliary receptacles or the 14 pin amphenol.
4. Disconnect and isolate GND-E lead from the bottom ground screw inside the left case front. See control Inner-Connection diagram. See Figure F.13.
5. Disconnect the #5 and #6 leads from the field bridge rectifier. See Wiring Diagram.
6. Using an ohmmeter, check the resistance between chassis ground and each of the following points; Resistance should read very high, 500,000 (500K) ohms minimum.
 - 1) Pin 1 at the 14 pin amphenol, and the #5 lead that had been disconnected from the ground screw. (this checks for a connection between the wire feed winding and the auxiliary winding.)
 - 2) Pin 1 of the 14 pin amphenol and lead #7 or #9. (This checks for a connection between the wire feed winding and the exciter winding.)
 - 3) Pin 1 of the 14 pin amphenol and lead W1, W2, or W3. (This checks for a connection between the wire feed winding and the weld winding).
 - 4) Lead #5 and lead #7 or #9. (This checks for a connection between the auxiliary winding and the weld winding). See Wiring Diagram.
 - 5) Lead #5 and lead W1, W2, or W3. (This checks for a connection between the auxiliary winding and the weld winding.) See Wiring Diagram.
 - 6) Lead #7 or #9 and lead W1, W2, or W3. (This checks for a connection between the exciter winding and the weld winding.) See Wiring Diagram.

If any of the above readings is less than 500,000 (500k) ohms, check for damaged, contaminated, or shorted wiring or components between the test points and the stator winding. If necessary, disconnect and isolate the stator leads as close to the stator winding as possible. See wiring diagram. If the low resistance is determined to be between the windings within the stator, the stator is defective and should be replaced*.

NOTE: The field bridge rectifier and field capacitor may appear to function normally when tested independently. But may malfunction when placed under the stress of normal operation. For this reason, It is recommended that the bridge rectifier and capacitor be replaced with known good components before replacing the stator.

OUTPUT RECTIFIER BRIDGE TEST**WARNING**

Service and repair should be performed by only Lincoln Electric factory trained personnel. Unauthorized repairs performed on this equipment may result in danger to the technician or machine operator and will invalidate your factory warranty. For your safety and to avoid electrical shock, please observe all safety notes and precautions detailed throughout this manual.

If for any reason you do not understand the test procedures or are unable to perform the test/repairs safely, contact the Lincoln Electric Service Department for electrical troubleshooting assistance before you proceed. Call 1-888-935-3877.

TEST DESCRIPTION

This test will determine if the Rectifier is grounded, or if there are any failed Diode groups.

NOTE: This test will not be able to detect individual open diodes within a group.

MATERIALS NEEDED

Miscellaneous Hand Tools
Analog Ohmmeter or Diode Tester (For testing diodes)
Ohm Meter (any type for ground test)

OUTPUT RECTIFIER BRIDGE TEST (CONTINUED)

FIGURE F.14

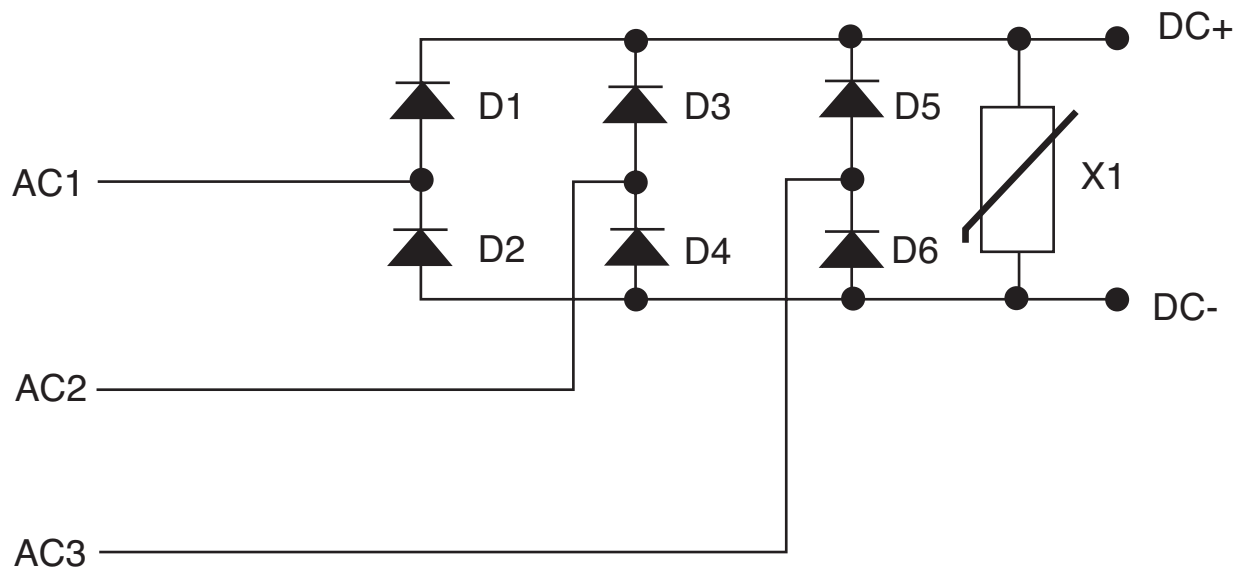

TEST PROCEDURE

1. Turn the engine off.
2. Perform the **Case Cover Removal Procedure**.
3. Perform the **Chopper Module Capacitor Discharge Procedure**.

Electrically isolate the three-phase input terminals of the output bridge rectifier as follows:

4. Mark leads W1, W2, and W3 so they can be properly reconnected after the test is complete. Remove these leads and position them so they do not come in contact with any part of the rectifier. See **Figure F.15**. See wiring diagram.

Electrically isolate the DC output terminals of the rectifier:

5. Mark the leads connected to the positive and negative terminals of the output bridge rectifier to assure that they can be reconnected properly. See **Figure F.15**.
6. Remove leads W4, W5, and W10 from the positive terminal of the Rectifier, and remove leads W6 and W11 from the negative terminal. Position these leads so they do not come into contact with any part of the rectifier. See **Figure F.15**. See the wiring diagram..

OUTPUT RECTIFIER BRIDGE TEST (CONTINUED)

7. Check for grounds by placing one of the ohm meter probes on a clean, unpainted metal surface of the machine. Touch the other probe to each of the five rectifier terminals. The resistance to chassis ground from each terminal should be very high, 500,000 (500K) ohms minimum. If the resistance reading is less than specified, the rectifier is grounded and should be replaced.
8. If using diode checker or a multimeter with diode check functionality, read and understand the instructions that accompany your test equipment.
9. If using an analog ohmmeter, the forward bias test will indicate low resistance and the reverse bias test will indicate high resistance. Precise ohm values for this test will vary depending on the test equipment used.

NOTE: A digital Ohmmeter is not recommended for this test. A typical digital Ohmmeter does not provide enough voltage or current flow to reliably test the diodes used in this rectifier.

10. Test all of the diode groups per the **Table F.1**.

FIGURE F.15 - SHUNT/RECTIFIER LEADS

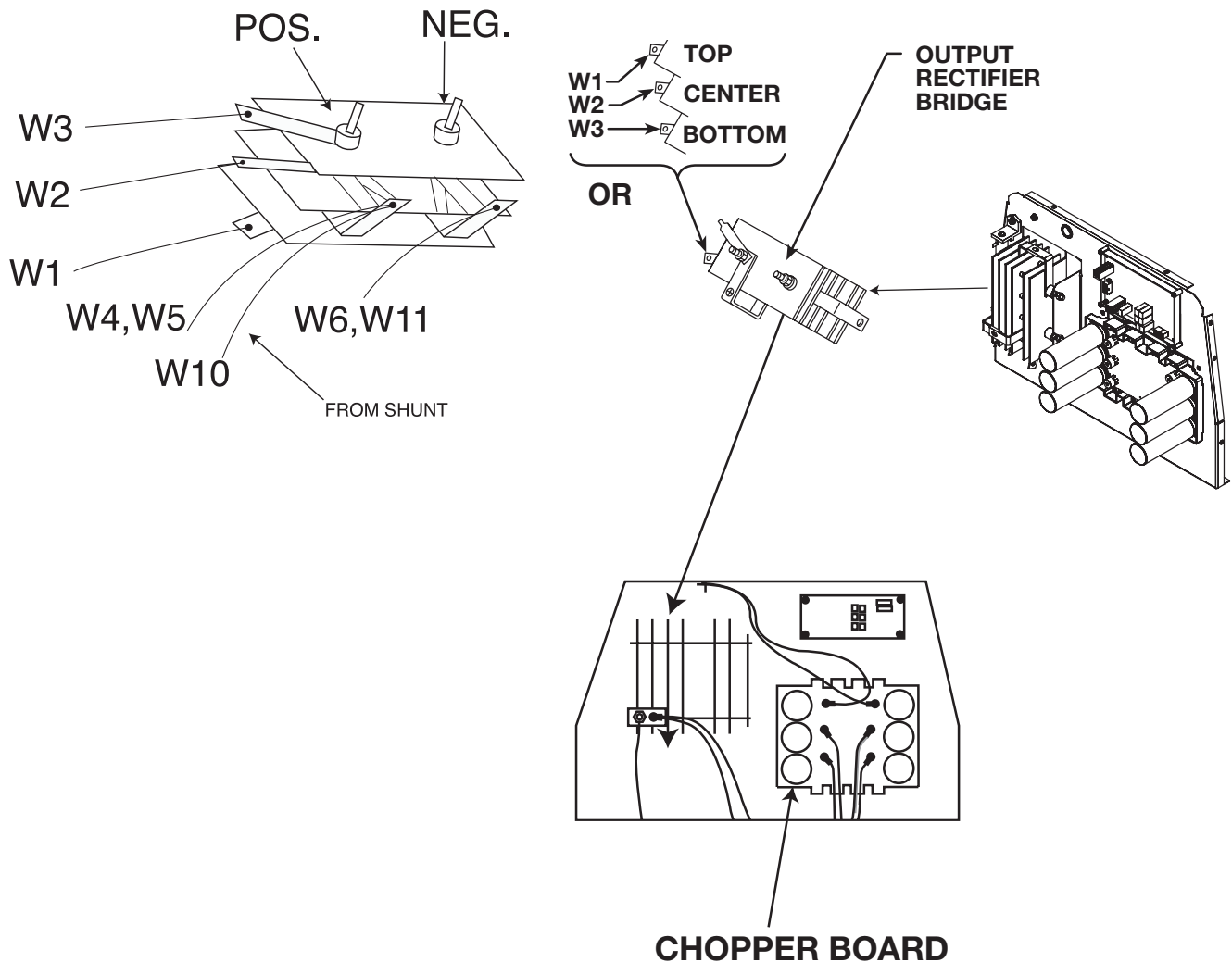

TABLE F.1 – DIODE TEST TABLE

Rectifier Terminal Connections	Test Instrument		
	(+) Lead	(-) Lead	Diode Bias and Expected Test Result
	AC1	DC(+)	FORWARD BIAS (Low Resistance)
	AC2	DC(+)	FORWARD BIAS (Low Resistance)
	AC3	DC(+)	FORWARD BIAS (Low Resistance)
	DC(-)	AC1	FORWARD BIAS (Low Resistance)
	DC(-)	AC2	FORWARD BIAS (Low Resistance)
	DC(-)	AC3	FORWARD BIAS (Low Resistance)
	AC1	DC(-)	REVERSE BIAS (High Resistance)
	AC2	DC(-)	REVERSE BIAS (High Resistance)
	AC3	DC(-)	REVERSE BIAS (High Resistance)
	DC(+)	AC1	REVERSE BIAS (High Resistance)
	DC(+)	AC2	REVERSE BIAS (High Resistance)
	DC(+)	AC3	REVERSE BIAS (High Resistance)

11. Reconnect all leads.

12. Perform the **Case Cover Replacement Procedure**.



WARNING

Service and repair should be performed by only Lincoln Electric factory trained personnel. Unauthorized repairs performed on this equipment may result in danger to the technician or machine operator and will invalidate your factory warranty. For your safety and to avoid electrical shock, please observe all safety notes and precautions detailed throughout this manual.

If for any reason you do not understand the test procedures or are unable to perform the test/repairs safely, contact the Lincoln Electric Service Department for electrical troubleshooting assistance before you proceed. Call 1-888-935-3877.

DESCRIPTION

This test will help determine if the Chopper Module is functioning properly, and receiving the correct input from the Output Rectifier and Control PC Board.

This test can only provide meaningful results if the machine is producing normal AC auxiliary output.

MATERIALS NEEDED

- Miscellaneous Hand Tools
- Digital Multi-Meter
- Frequency counter or digital multi-meter with frequency counter function.
- Wiring Diagram
- Control Inner-Connection Diagram

CHOPPER MODULE FUNCTION TEST (CONTINUED)

FIGURE F.16 - CHOPPER MODULE CONNECTIONS

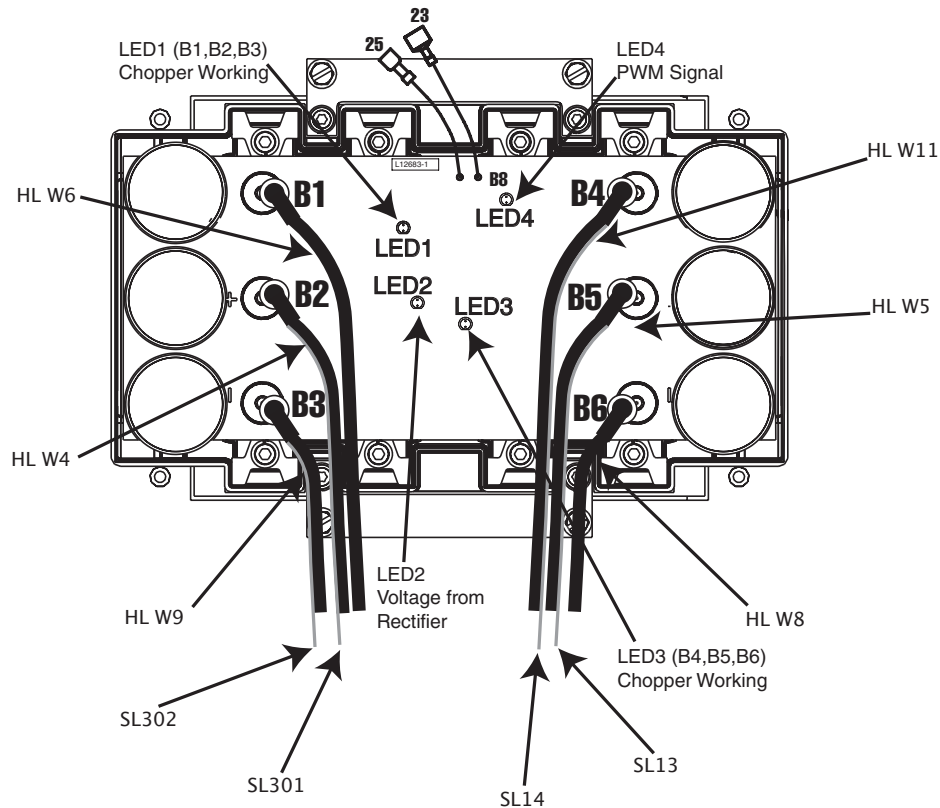

TEST PROCEDURE

1. Perform the **Case Cover Removal Procedure**.
2. Make sure that there is nothing plugged into either of the Amphenol receptacles.
3. Place idle switch in the "HIGH" position.
4. Place the mode switch in the "CC-STICK" position.
5. Place the Welding Terminal switch in the "REMOTELY CONTROLLED" position.
6. Start the engine and allow it to stabilize at high idle RPM.
7. Check for 80 to 100 VDC at terminals B1- to B2+ and B4- to B5+ of the chopper module. See wiring diagram and figure #1.
8. If the correct DC voltage is not present at terminals B1- to B2+ and B4- to B5+, check for damaged conductors or faulty connections between the chopper module, the output rectifier, and the stator weld winding. See Figure F.17. See the wiring diagram. Perform the **Stator Voltage Tests**, and the **Output Rectifier Test**.
9. If the correct voltage is present at terminals B1- to B2+ and B4- to B5+ of the chopper module, check for DC voltage at the chopper module terminals B2+ to B3-, and B5+ to B6-. If significant voltage is present, disconnect leads #23 and #25 from the chopper module PC board. If voltage is still present, the copper module is shorted and should be replaced.
10. If the voltage drops to 0 VDC after the #23 and #25 leads have been disconnected, the control PC board is driving the chopper module when it should not be doing so. Reconnect the #23 and #25 leads and perform the **Weld Control Board Gate Drive Test**.
11. Reconnect leads #23 and #25, and place the Welding Terminal switch in the "WELD TERMINALS ON" position.
12. Check for about 58 VDC between Chopper Module Terminals B2+ to B3-, and B5+ to B6 and between the welder output terminals. See Figure F.16. See the wiring diagram.

CHOPPER MODULE FUNCTION TEST (CONTINUED)**TEST PROCEDURE (CONTINUED)**

13. If about 58 VDC is present at chopper module terminals B2+ to B3-, and B5+ to B6-, but not at the output terminals, there is a problem between the chopper module and one of the output terminals. Check for damaged conductors or faulty connections, on leads W7, W8, W9, and W10. Also check the shunt, the choke, and the connections at the back of the output terminals. See the wiring diagram.
14. If the voltage at terminals B2+ to B3-, and B5+ to B6- of the Chopper module is significantly higher than 58 VDC, check for an open R4 load resistor. See the Control Inner-Connection diagram. Also check for damaged conductors or faulty connections at leads #302 and #302. See wiring diagram.
15. If the voltage at terminals B2+ to B3-, and B5+ to B6- of the chopper module is very low, or not present, use the frequency counter to check for the presents of a 20 kHz PWM signal between leads #23 +and #25-, where they connect to the chopper module PC board.
16. If the 20 kHz signal is present, the chopper module is defective. Replace.
17. If the 20 kHz signal is not present, perform the **Weld Control Board PWM Gate Signal Test**.
18. If the weld control board is producing a PWM gate signal, check th e#23 and #25 leads for damaged conductors and faulty connections between the control PC board and the chopper module.
19. If testing is complete, Perform the **Case Cover Replacement Procedure**.

TROUBLESHOOTING & REPAIR

CHOPPER MODULE RESISTANCE TEST



WARNING

Service and repair should be performed by only Lincoln Electric factory trained personnel. Unauthorized repairs performed on this equipment may result in danger to the technician or machine operator and will invalidate your factory warranty. For your safety and to avoid electrical shock, please observe all safety notes and precautions detailed throughout this manual.

If for any reason you do not understand the test procedures or are unable to perform the test/repairs safely, contact the Lincoln Electric Service Department for electrical troubleshooting assistance before you proceed. Call 1-888-935-3877.

TEST DESCRIPTION

This test will help determine if the Chopper Module is shorted. This test can only detect some problems in the "Power" section of the module. Problems in some other PC board components may not be detected.

MATERIALS NEEDED

Miscellaneous Hand Tools
Digital Ohmmeter
Wiring Diagram

CHOPPER MODULE RESISTANCE TEST (CONTINUED)**TEST PROCEDURE**

1. Perform the ***Case Cover Removal Procedure***.
2. Perform the ***Capacitor Discharge Procedure***.
3. Check that all of the leads connected to the chopper module terminals are clearly marked to facilitate reassembly. Remove all of the leads from the chopper module and position them so they do not make electrical contact with any part of the module. See the wiring diagram.
4. Use a digital Ohmmeter to test the module per ***Table F.2***.

CHOPPER MODULE RESISTANCE TEST (CONTINUED)

FIGURE F.2 - DIODE TEST TABLE

Chopper Terminal Connections	OHMMETER		OHMMETER READING
	(+) Lead	(-) Lead	Diode Bias and Expected Test Result
	B5	B6	6K to 9K
	B6	B5	6K to 9K
	B4	B5	200k or higher
	B5	B4	400k or higher
	B4	B6	200k or higher
	B6	B4	400k or higher
	B2	B3	6K to 9K
	B3	B2	6K to 9K
	B4	B2	200k or higher
	B2	B4	400k or higher
B4	B3	200k or higher	
B3	B4	400k or higher	

5. Reconnect all leads.
6. The chopper module screw connection should be lightened to 50-60 inch-pounds.
7. Perform the **Case Cover Replacement Procedure**.

WELD CONTROL BOARD PWM GATE SIGNAL TEST**WARNING**

Service and repair should be performed by only Lincoln Electric factory trained personnel. Unauthorized repairs performed on this equipment may result in danger to the technician or machine operator and will invalidate your factory warranty. For your safety and to avoid electrical shock, please observe all safety notes and precautions detailed throughout this manual.

If for any reason you do not understand the test procedures or are unable to perform the test/repairs safely, contact the Lincoln Electric Service Department for electrical troubleshooting assistance before you proceed. Call 1-888-935-3877.

DESCRIPTION

This test will determine if the Weld Control PC Board is able to produce the PWM (Pulse Width Modulated) gate signal needed to control the IGBTs (Insulated Gate Bipolar Transistor) on the Chopper Module. This test will also verify that the Control PC Board can turn the PWM gate signal on and off properly.

MATERIALS NEEDED

Digital Multi-Meter
Frequency Counter or digital Multi-meter with frequency counter function
Wiring Diagram
Control Inner-Connection Diagram

WELD CONTROL BOARD PWM GATE SIGNAL TEST (CONTINUED)

TEST PROCEDURE

1. Perform the **Case Cover Removal Procedure**.
2. Unplug any device that may be attached to either the 6 pin or the 14 pin Amphenol receptacles.
3. Place the idle switch in the "HIGH IDLE" position.
4. Place the mode switch in the "CC-STICK" position.
5. Place the Weld terminals switch in the "WELD TERMINALS ON" position.
6. Start the engine and let it run and stabilize at high idle RPM.
7. Locate plug P3 on the control PC board. See Control Inner-Connection diagram.
8. Use the frequency counter to test for 20kHz PWM gate signal between leads #23+ (P3-10) and #25- (P3-9).
9. If the 20KHz gate signal is present, place the weld terminals switch in the "REMOTELY CONTROLLED" position. The gate signal should turn off.
10. If the 20 KHz gate signal responds as described above, this test is complete.
11. If there is no 20 KHz gate signal, test for the presents of 80 to 100 VDC, at leads 13+ (P3-8) to 14- (P3-16) of the weld control PC board.
12. If voltage is very low or not present, check leads #13 and #14 for faulty or damaged wiring or connections between the control PC board and the chopper module.
13. Test for 80 to 100 VDC at the terminals where the #13 and #14 leads connect to the chopper module. See the wiring diagram. If there is no voltage at the chopper module, perform the chopper module function test.
14. If the 80 to 100 VDC supply voltage is present at the weld control PC board, but there is no PWM gate signal, check the voltage between leads #2+ (P1-4) and #4 (P1-3). See figure #1
The voltage should be about 0 VDC.
15. If about 5 VDC is detected, the welding terminal control circuit is open. Check for damaged leads for faulty connections at leads #2 and #4; also check for a defective welding terminal switch. See the wiring diagram.
16. If the PWM signal remains after the welding terminal switch has been placed in the "REMOTELY CONTROLLED" position, check the voltage between leads #2+ (P1-4) and #4- (P1-3) at the control PC board.
17. If the voltage reads 0 or very near 0, Check for damaged insulation at leads #2 and #4, also check for a shorted welding terminal switch, or damaged or contaminated Amphenol receptacle. See the wiring diagram.
18. If the above wiring and components are undamaged and functioning properly, the control PC board is defective and should be replaced.
19. If the voltage reads about 5 VDC, and the PWM signal remains, the control PC board is defective and should be replaced.
20. Perform the **Case Cover Replacement Procedure**.

WELD CONTROL FEEDBACK TEST**WARNING**

Service and repair should be performed by only Lincoln Electric factory trained personnel. Unauthorized repairs performed on this equipment may result in danger to the technician or machine operator and will invalidate your factory warranty. For your safety and to avoid electrical shock, please observe all safety notes and precautions detailed throughout this manual.

If for any reason you do not understand the test procedures or are unable to perform the test/repairs safely, contact the Lincoln Electric Service Department for electrical troubleshooting assistance before you proceed. Call 1-888-935-3877.

DESCRIPTION

This test will determine if the Weld Control PC Board is receiving accurate current and voltage feedback from the weld circuit.

This test will only yield usable information if the machine is producing some weld output.

MATERIALS NEEDED

Digital Multi-meter suitable for accurate readings in both the millivolt and normal weld voltage ranges.

Resistive Load Bank

Ammeter, suitable for accurate readings of normal welding current. (Often built into the load bank.)

Wiring Diagram

Control Inner-Connection Diagram

WELD CONTROL FEEDBACK TEST (CONTINUED)**TEST PROCEDURE**

1. Place the idle switch in the "HIGH IDLE" position.
2. Place the mode switch in the "CC-STICK" position.
3. Place the weld terminals switch in the "WELD TERMINALS ON" position.
4. Make sure that nothing is plugged into either Amphenol receptacle.
5. Connect the resistive load bank and the ammeter to the weld output terminals per the equipment manufacturer's instructions; also connect the voltmeter probes across the weld output terminals.
6. Start the machine and, apply a load of about 200 Amps, as shown on the external ammeter. If the machine will not produce 200 amps, apply as much load as you can.
7. Compare the readings shown on the external ammeter and voltmeter to the amps and volts displayed on the front panel of the machine.
8. If the readings shown on the front panel displays are about the same or very close to the reading on the external meters, the feedback is probably good, and this test is complete.
9. If the readings differ significantly, continue with this procedure
10. Turn off the engine and release the load from the weld terminals. (The load bank and ammeter should remain connected, but the load should be released.)
11. Perform the **Case Cover Removal Procedure**.
12. Locate plugs P3 and P6 on the control PC board. See figure #1. Remove the plugs and check for dirt, corrosion, damaged, expanded, or incorrectly positioned terminals. Repair or replace wiring components as needed and reconnect the plugs to the control board.
13. Restart the machine and apply a load across the weld terminals that measures about 200 amps. If the machine will not produce 200 amps of current, apply as much load as you can.
14. Using the voltmeter, measure and note the DC voltage at the weld output terminals.
15. Check the voltage between leads #204S+ (P6-1) and lead #208B- (P3-15) at the control PC board Molex plugs. The voltage should be the same as was measured at the weld terminals.

WELD CONTROL FEEDBACK TEST (CONTINUED)

16. If the voltage readings are different, check the wiring and connections between the welding terminals and the control PC board. See the wiring diagram.
17. Connect the millivolt meter probes between lead #206S+ (P6-2) and lead 204S- (P6-1). See Wiring Diagram. If the machine is currently producing 200 amps the millivolt meter should read about 25 millivolts.
18. If the machine cannot produce 200 amps of weld current, the correct millivolt signal will need to be calculated by dividing the reading displayed on the external ammeter by 8. See the following explanation.
19. The shunt used in this machine will produce 50 millivolts at a load of 400 amps, or 8 amps per millivolt.
20. To calculate the correct millivolt signal for a given load, you divide the number of amps displayed on the ammeter by 8.

Example: If your ammeter reads 75, ($75/8 = 9.4$) If the shunt is working correctly, and the wiring between the shunt and the control PC board is in good condition, the meter connected at the control PC board should be reading about 9.4 millivolts.
21. If the millivolt reading is incorrect, check the wiring between the shunt and the control PC board for damage, grounds, and faulty connections. If the wiring is good, the shunt and lead assembly is faulty and should be replaced.
22. Perform the ***Case Cover Replacement Procedure***.

CONTROL POTENTIOMETER AND MODE SWITCH RESISTANCE TEST**WARNING**

Service and repair should be performed by only Lincoln Electric factory trained personnel. Unauthorized repairs performed on this equipment may result in danger to the technician or machine operator and will invalidate your factory warranty. For your safety and to avoid electrical shock, please observe all safety notes and precautions detailed throughout this manual.

If for any reason you do not understand the test procedures or are unable to perform the test/repairs safely, contact the Lincoln Electric Service Department for electrical troubleshooting assistance before you proceed. Call 1-888-935-3877.

DESCRIPTION

This test will check the Output Control Potentiometer, Arc Control Potentiometer, Mode Switch and associated wiring for damage, proper operation, tracking and grounds.

MATERIALS NEEDED

Digital Ohmmeter
Wiring Diagram
Control Inner-Connection Diagram

CONTROL POTENTIOMETER AND MODE SWITCH RESISTANCE TEST (CONTINUED)

TEST PROCEDURE

1. Turn the engine off
2. Perform the **Case Cover Removal Procedure**.
3. Unplug P7 from control board, see control Inner-connection diagram, and visually check the plug and attached wiring for damage, corrosion, improperly seated or damaged contact pins. P7 will remain unplugged for following test.
4. Set the mode switch in the "CC-Stick" position.
5. Test the resistance between each of the leads in P7 and a good clean chassis ground connection. Be very careful that the connection pins in P7 are not damaged or spread out.
6. The resistance should be very high. A reading of 500,000 (500k) ohms or higher is acceptable.
7. If the resistance is lower than 500k Ohms, replace the potentiometer and mode switch plug and lead assembly, or replace the defective component within the assembly. See wiring diagram.
8. Perform the resistance tests per **Table F.3**.
9. If the resistance readings are not as specified in the table, replace the potentiometer and mode switch plug and lead assembly, or replace the defective component. See the wiring diagram.
10. If testing is complete, plug P7 back into the control PC board and perform the **Case Cover Replacement Procedure**.

CONTROL POTENTIOMETER AND MODE RESISTANCE TEST (CONTINUED)

TABLE F.3

POT/MODE SWITCH RESISTANCE TEST		
MODE SWITCH SETTING	OHMMETER CONNECTION	
CC-STICK	P7-9 (#214) TO P7-14 (#218)	500K or Higher
CC-STICK	P7-9 (#214) TO P7-15 (#220)	500K or Higher
CC-STICK	P7-9 (#214) TO P7-16 (#222)	500K or Higher
CC-STICK	P7-14 (#218) TO P7-15 (#220)	500K or Higher
CC-STICK	P7-14 (#218) TO P7-16 (#222)	500K or Higher
CC-STICK	P7-15 (#220) TO P7-16 (#222)	500K or Higher
TOUCH START TIG	P7-15 (#220) TO P7-16 (#222)	*
DOWNHILL PIPE	P7-14 (#218) TO P7-16 (#222)	*
CV-WIRE	P7-9 (#214) TO P7-16 (#222)	*
N/A	P7-5 (#75) TO P7-1 (#77)	about 10K
N/A	P7-1 (#77) TO P7-4 (#76)	Ohms values should sweep smoothly from 10K to 0 when ARC CONTROL is turned from Min. to Max.
N/A	P7-6 (#279) TO P7-8 (#277)	about 10K
N/A	P7-8 (#277) TO P7-7 (#278)	Ohms values should sweep smoothly from 10K to 0 when ARC CONTROL is turned from Min. to Max.

* Resistance should be very low, The Ohmmeter should read about the same value as one would get by touching the two meter probes together.

TROUBLESHOOTING & REPAIR

REMOTE RECEPTACLE RESISTANCE TEST



WARNING

Service and repair should be performed by only Lincoln Electric factory trained personnel. Unauthorized repairs performed on this equipment may result in danger to the technician or machine operator and will invalidate your factory warranty. For your safety and to avoid electrical shock, please observe all safety notes and precautions detailed throughout this manual.

If for any reason you do not understand the test procedures or are unable to perform the test/repairs safely, contact the Lincoln Electric Service Department for electrical troubleshooting assistance before you proceed. Call 1-888-935-3877.

DESCRIPTION

This test will help determine if there is a problem with the Remote Receptacle control wiring, relating to electrical tracking between other control conductors, power conductors, or ground. This test also checks the function of the weld terminal switch.

MATERIALS NEEDED

- Ohm Meter
- Wiring Diagram
- Control Inner-Connection Diagram

REMOTE RECEPTACLE RESISTANCE TEST (CONTINUED)

FIGURE F.17

AMPHENOL 1

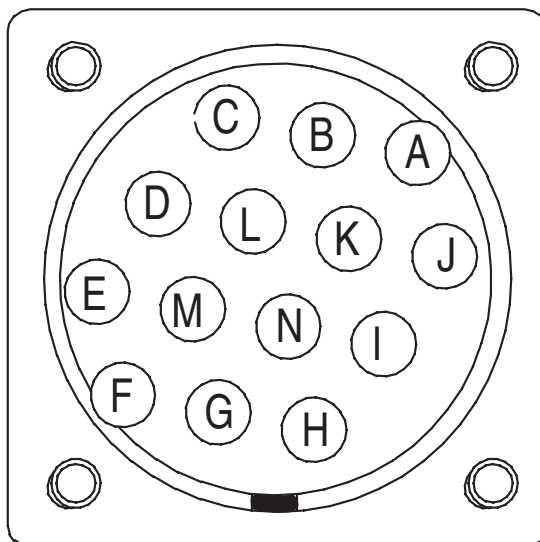

TEST PROCEDURE

1. Turn the machine off.
2. Perform the **Case Cover Removal Procedure**.
3. Make sure that there are no devices of any kind plugged into either Amphenol receptacles.
4. Remove Molex plug P1 from the control PC board, see Control Inner-Connection Diagram. Examine the Molex plug and the receptacle on the control PC board for dirt, corrosion, damaged or out-of-position pins. Repair or replace any damaged components. Position the P1 plug so it can not make electrical contact with any other conductor or chassis ground.
5. Perform the following resistance tests shown in the following table. Be very careful not to damage or spread any of the connection pins in the Amphenol receptacle. See **Table F.4**.
6. If the measured resistance does not meet values specified, check for damage, dirt or moisture contamination in the Amphenol receptacles and the P1 Molex plug. Check for damaged or grounded wiring.
7. If the resistance values are found to be too low, due to contaminated electrical components in the Amphenol harness assembly. Try removing the contamination and drying the components completely. If the resistance values are still too low, replace the Amphenol harness assembly.
8. If the values are incorrect for the last two tests in the table, (Pin C to Pin D) check the welding terminal switch and the wiring connected to that switch. See the wiring diagram. Repair any faulty connections or replace the switch if necessary.
9. Plug P1 back into the Control PC board.
10. Perform the **Case Cover Replacement Procedure**.

REMOTE RECEPTACLE RESISTANCE TEST (continued)

TABLE - F.4

AMPHENOL RESISTANCE TEST		
WELDING TERMINAL SWITCH SETTING	OHMMETER CONNECTION	OHMMETER READING
N/A	PIN "G" (#75B) to PIN "A" (#32)	500K or Higher
N/A	PIN "G" (#75B) to PIN "B" (GND-A)	500K or Higher
N/A	PIN "G" (#75B) to PIN "C" (#2B)	500K or Higher
N/A	PIN "G" (#75B) to PIN "D" (#4B)	500K or Higher
N/A	PIN "G" (#75B) to PIN "E" (#77B)	500K or Higher
N/A	PIN "G" (#75B) to PIN "F" (#76B)	500K or Higher
N/A	PIN "G" (#75B) to PIN "H" (#21)	500K or Higher
N/A	PIN "G" (#75B) to PIN "I" (#41A)	500K or Higher
N/A	PIN "G" (#75B) to PIN "J" (#31)	500K or Higher
N/A	PIN "G" (#75B) to PIN "K" (#42A)	500K or Higher
N/A	PIN "F" (#76B) to PIN "A" (#42)	500K or Higher
N/A	PIN "F" (#76B) to PIN "B" (GND-A)	500K or Higher
N/A	PIN "F" (#76B) to PIN "C" (#2B)	500K or Higher
N/A	PIN "F" (#76B) to PIN "D" (#4B)	500K or Higher
N/A	PIN "F" (#76B) to PIN "E" (#77B)	500K or Higher
N/A	PIN "F" (#76B) to PIN "H" (21)	500K or Higher
N/A	PIN "F" (#76B) to PIN "I" (#41A)	500K or Higher
N/A	PIN "F" (#76B) to PIN "J" (#31)	500K or Higher
N/A	PIN "F" (#76B) to PIN "K" (#42A)	500K or Higher
N/A	PIN "E" (#77B) to PIN "A" (#32)	500K or Higher
N/A	PIN "E" (#77B) to PIN "B" (GND-2)	500K or Higher
N/A	PIN "E" (#77B) to PIN "C" (#2B)	500K or Higher
N/A	PIN "E" (#77B) to PIN "D" (#4B)	500K or Higher
N/A	PIN "E" (#77B) to PIN "H" (#21)	500K or Higher
N/A	PIN "E" (#77B) to PIN "I" (#41A)	500K or Higher
N/A	PIN "E" (#77B) to PIN "J" (#31)	500K or Higher
N/A	PIN "E" (#77B) to PIN "K" (42A)	500K or Higher
REMOTELY CONTROLLED	PIN "C" (#2B) to PIN "D" (#4B)	500K or Higher
WELD TERMINALS ON	PIN "C" (#2B) to PIN "D" (#4B)	*

*Resistance should be very low, The Ohmmeter should read about the same value as one would get by touching the two meter probes together.

NORMAL OPEN CIRCUIT VOLTAGE WAVEFORM (115VAC SUPPLY)

HIGH IDLE – NO LOAD

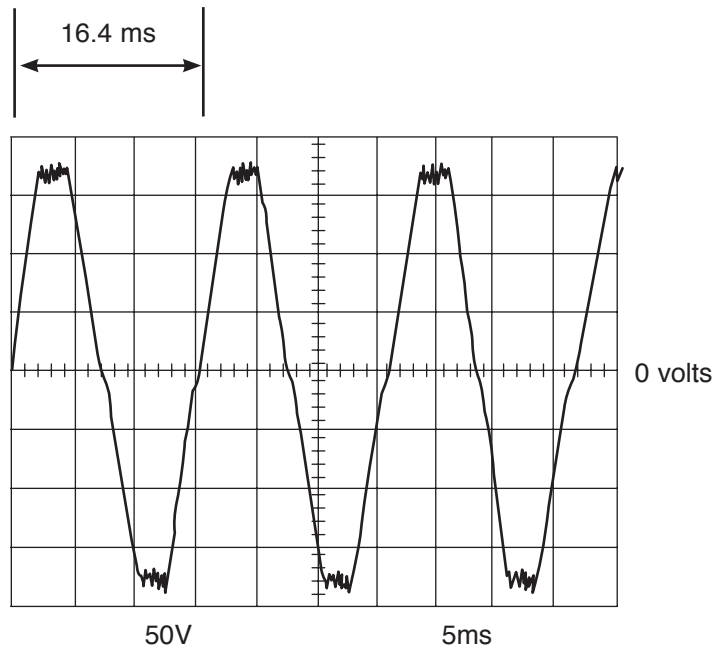

This is the typical auxiliary output voltage generated from a properly operating machine. Note that each vertical division represents 50 volts and that each horizontal division represents 5 milliseconds in time.

NOTE: Scope probes are connected at machine 120 VAC receptacle.

SCOPE SETTINGS

Volts/Div	50V/Div.
Horizontal Sweep	5 ms/Div.
Coupling	DC
Trigger	Internal

NORMAL OPEN CIRCUIT VOLTAGE WAVEFORM (115VAC SUPPLY)

MAX CONTROL POT - HIGH IDLE - NO LOAD

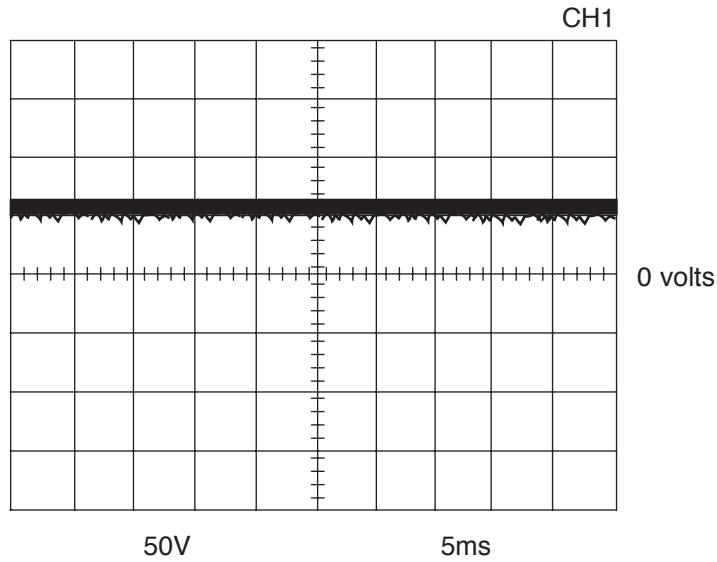

This is the typical DC open circuit output voltage generated from a properly operating machine. Note that each vertical division represents 50 volts and that each horizontal division represents 5 milliseconds in time.

NOTE: Scope probes are connected at weld output terminals.

SCOPE SETTINGS

Volts/Div	50V/Div.
Horizontal Sweep	5 ms/Div.
Coupling	DC
Trigger	Internal

NORMAL OPEN CIRCUIT VOLTAGE WAVEFORM (115VAC SUPPLY)

MACHINE LOADED TO 300 AMPS AT 27 VOLTS

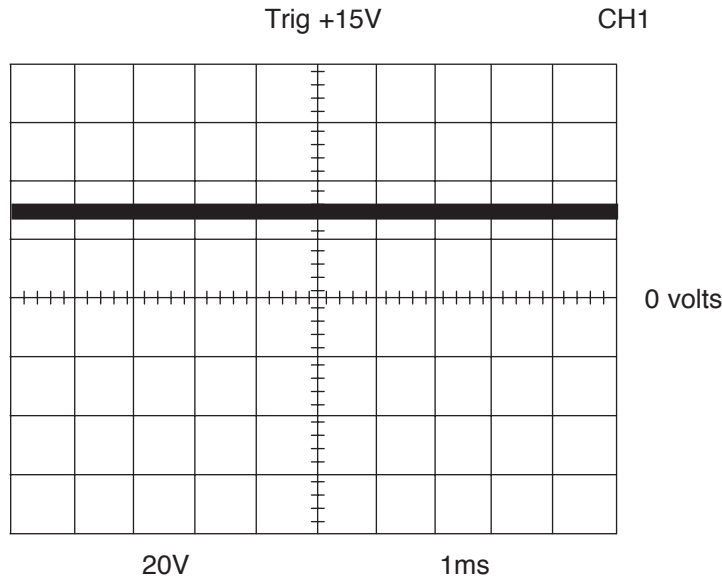

This is the typical DC output voltage generated from a properly operating machine. Note that each vertical division represents 20 volts and that each horizontal division represents 1 millisecond in time.

The machine was loaded with a resistance grid bank to 300 amps at 27 volts.

NOTE: Scope probes are connected at weld output terminals.

SCOPE SETTINGS

Volts/Div	20V/Div
Horizontal Sweep	1 ms/Div.
Coupling	DC
Trigger	Internal

NORMAL OPEN CIRCUIT VOLTAGE WAVEFORM (WIRE CV TAP)

MAX CONTROL POT - HIGH IDLE - NO LOAD

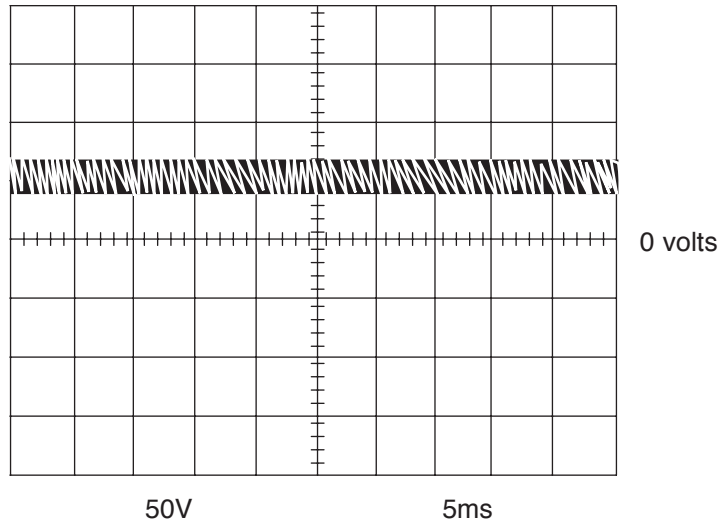

This is the typical DC open circuit output voltage generated from a properly operating machine. Note that each vertical division represents 50 volts and that each horizontal division represents 5 milliseconds in time.

NOTE: Scope probes are connected at weld output terminals.

SCOPE SETTINGS

Volts/Div	50V/Div.
Horizontal Sweep	5 ms/Div.
Coupling	DC
Trigger	Internal

NORMAL CIRCUIT VOLTAGE WAVEFORM (WIRE CV)

MACHINE LOADED TO 300 AMPS AT 28 VOLTS

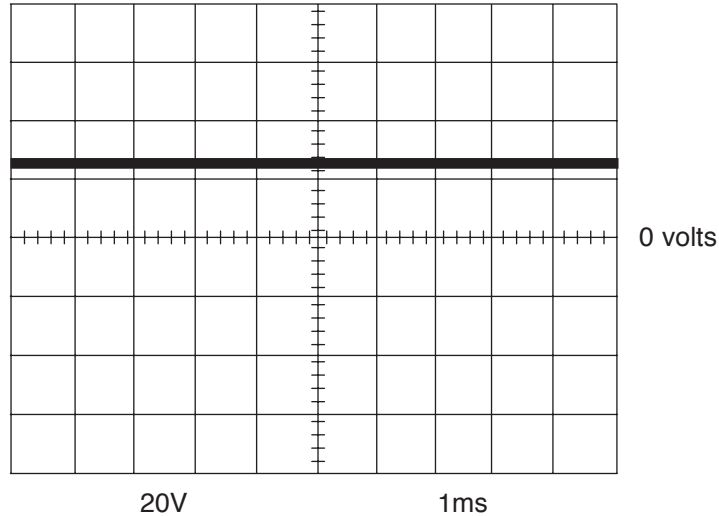

This is the typical DC voltage generated from a properly operating machine. Note that each vertical division represents 20 volts and that each horizontal division represents 1 millisecond in time.

The machine was loaded with a resistance grid bank to 300 amps at 28 volts.

NOTE: Scope probes are connected at weld output terminals.

SCOPE SETTINGS

Volts/Div	20V/Div.
Horizontal Sweep	1 ms/Div.
Coupling	DC
Trigger	Internal

OUTPUT RECTIFIER BRIDGE AND CHOKE REMOVAL AND REPLACEMENT



WARNING

Service and repair should be performed by only Lincoln Electric factory trained personnel. Unauthorized repairs performed on this equipment may result in danger to the technician or machine operator and will invalidate your factory warranty. For your safety and to avoid electrical shock, please observe all safety notes and precautions detailed throughout this manual.

If for any reason you do not understand the test procedures or are unable to perform the test/repairs safely, contact the Lincoln Electric Service Department for electrical troubleshooting assistance before you proceed. Call 1-888-935-3877.

DESCRIPTION

The following procedure will aid the technician in removing and replacing the Output Rectifier Bridge and the Choke in the Vantage® 400.

MATERIALS NEEDED

- Miscellaneous Hand Tools
- Penetrox Heat Sink Compound (Lincoln Part T12837-1)

OUTPUT RECTIFIER BRIDGE AND CHOKE REMOVAL AND REPLACEMENT (CONTINUED)

REMOVAL PROCEDURE

1. Turn the engine off.
2. Remove negative battery cable.
3. Perform the **Case Cover Removal Procedure**.
4. Perform the **Chopper Module Capacitor Discharge Procedure**.
5. Remove the four screws holding the case front to the base of the machine.
6. Remove all plugs and leads from the weld control and pull coil PC boards. Be sure to mark the leads and plugs so they can be properly re-connected. See wiring diagram.
7. Remove the screws holding the D4 diode bridge and the CR1 engine protection relay to the center baffle assembly, and allow these components to remain attached to the case front wiring.
8. Remove any additional wiring and cable ties as needed. Carefully mark leads for accurate re-connection.
9. Swing the case front to the side to permit access to the Output Rectifier and Choke.

Removing the Output Rectifier

10. Remove the heavy leads from the output rectifier. Carefully mark the leads for accurate re-connection, and also note the order and position of multiple lead connections.
11. Remove the nuts and lock washers holding the Output Rectifier to the mounting bracket. You will need to reach through the large access holes on either side of the rectifier to reach these nuts.
12. Remove the Output Rectifier from the machine.

Removing the Output Choke

1. Remove the heavy leads from the choke. Carefully mark the leads for accurate re-connection, and also note the order and position of the leads in multiple lead connections.
2. Remove the three long bolts, lock washers and nuts holding the choke the mounting bracket in the machine base. Note that there is no bolt in the lower right corner of the choke.
3. Carefully remove the choke.

REPLACEMENT PROCEDURE

Replacing the Output Choke

1. Place the choke into the machine so that the three mounting holes in the choke line up with the holes in the mounting bracket.
2. Insert the three long bolts through the choke and the mounting bracket. Place a lock washer and nut on the end of each bolt and tighten.
3. Reconnect the choke leads. Position the leads, bolts, washers, and nuts exactly as they had been originally connected. Tighten the connection securely.

OUTPUT RECTIFIER BRIDGE AND CHOKE REMOVAL AND REPLACEMENT (CONTINUED)

Replacing the Output Rectifier

1. Place the Output Rectifier into the machine so that its mounting studs fit into the holes in the bracket. Place a lock washer and a nut on each stud and tighten.
2. Apply a thin film of Penetrox heat sink compound (Lincoln Part T12837-1) between the surfaces of the "W" leads and the Output Rectifier. Reconnect the Output Rectifier, positioning the leads, bolts, washers, and nuts exactly as they had been originally connected. Tighten all of the connections securely. See Wiring Diagram.
3. Swing the case front back into position.
4. Attach the case front to the machine base with four screws.
5. Reconnect all of the leads and plugs that were disconnected during the removal procedure, and replace any cable ties that were removed.
6. Perform the ***Case Cover Removal Procedure***.

CHOPPER MODULE REMOVAL AND REPLACEMENT**WARNING**

Service and repair should be performed by only Lincoln Electric factory trained personnel. Unauthorized repairs performed on this equipment may result in danger to the technician or machine operator and will invalidate your factory warranty. For your safety and to avoid electrical shock, please observe all safety notes and precautions detailed throughout this manual.

If for any reason you do not understand the test procedures or are unable to perform the test/repairs safely, contact the Lincoln Electric Service Department for electrical troubleshooting assistance before you proceed. Call 1-888-935-3877.

DESCRIPTION

This procedure will aid the technician in the removal and replacement of the Chopper Module Assembly.

NOTE: The Chopper Module assembly is removed and replaced as a unit. It contains no serviceable parts.

MATERIALS NEEDED

Miscellaneous Hand Tools
Penetrox Heat Sink Compound (Lincoln Part T12837-1)

CHOPPER MODULE REMOVAL AND REPLACEMENT (CONTINUED)

FIGURE F.18 - MODULE LEAD LOCATIONS

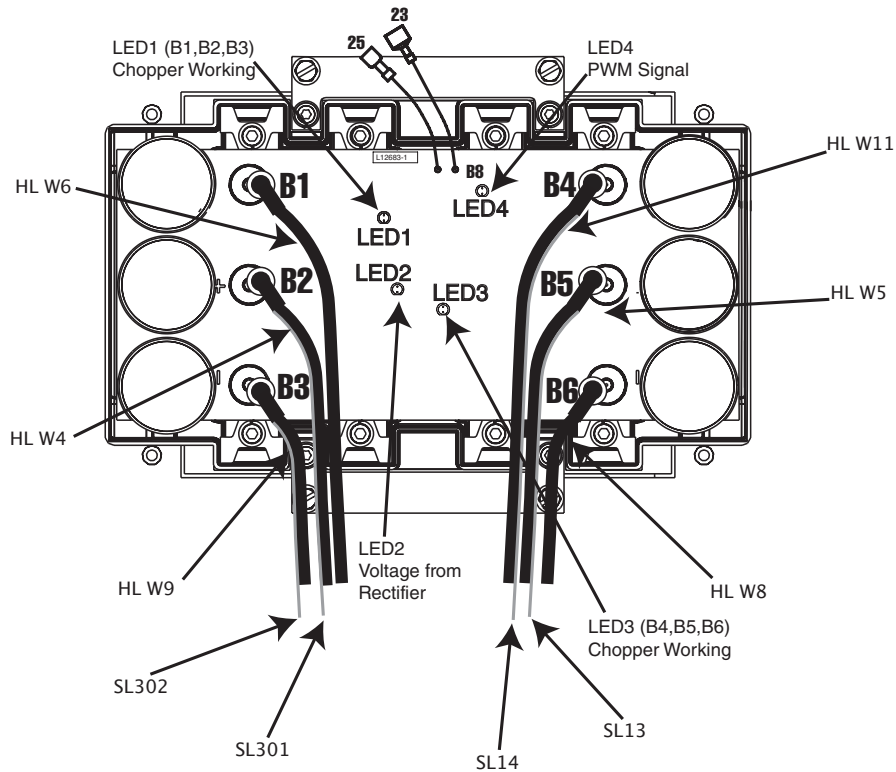

PROCEDURE

REMOVAL

1. Turn the engine off.
2. Perform the **Case Cover Removal Procedure**.
3. Perform the **Chopper Module Capacitor Discharge Procedure**.
4. Disconnect leads 23 and 25 at their in-line couplings.
5. Using the 7/16" socket wrench, remove the following leads. Label the leads before removal. Cut cable ties as needed. Note placement of leads and fasteners: screw, lock washer, flat washer, small lead, heavy lead.
6. Using a 3/8" socket wrench, remove the three screws holding the power module assembly to its brackets on the vertical baffle. Remove the plastic strip with the top two screws. Be sure to support the Power Module as you remove the last screw.
7. Remove the Power Module assembly from the machine.

TERMINAL	LEADS
B4	Heavy lead W11, Small lead 14
B5	Heavy lead W5, Small lead 13
B6	Heavy lead W8
B1	Heavy lead W6
B2	Heavy lead W4, Small lead 301
B3	Heavy lead W9, Small lead 302

CHOPPER MODULE REMOVAL AND REPLACEMENT (CONTINUED)**REPLACEMENT**

1. Mount the heat sink to the brackets on the vertical baffle with the three 3/8" screws. Mount the plastic strip with the top two screws.
2. Connect leads 23 and 25 at their in-line couplers.
3. Using a 7/16" wrench, attach the heavy leads and small leads as follows. Note placement of leads and fasteners: screw, lock washer, flat washer, small lead, heavy lead. Apply a thin coating of Penetrox heat sink compound (Lincoln Part T12837-1) to the mating surfaces (but not the threads). Tighten the fasteners to between 50-60 in-lbs.
4. Replace any cable ties cut at disassembly.
5. When procedures are complete, perform the ***Case Cover Replacement Procedure***.

STATOR/ROTOR REMOVAL AND REPLACEMENT PROCEDURE**WARNING**

Service and repair should be performed by only Lincoln Electric factory trained personnel. Unauthorized repairs performed on this equipment may result in danger to the technician or machine operator and will invalidate your factory warranty. For your safety and to avoid electrical shock, please observe all safety notes and precautions detailed throughout this manual.

If for any reason you do not understand the test procedures or are unable to perform the test/repairs safely, contact the Lincoln Electric Service Department for electrical troubleshooting assistance before you proceed. Call 1-888-935-3877.

TEST DESCRIPTION

This procedure will aid the technician in the removal and replacement of the Rotor and Stator.

MATERIALS NEEDED

Misc Hand Tools

STATOR/ROTOR REMOVAL AND REPLACEMENT PROCEDURE (CONTINUED)

FIGURE F.19 – FUEL TANK REMOVAL

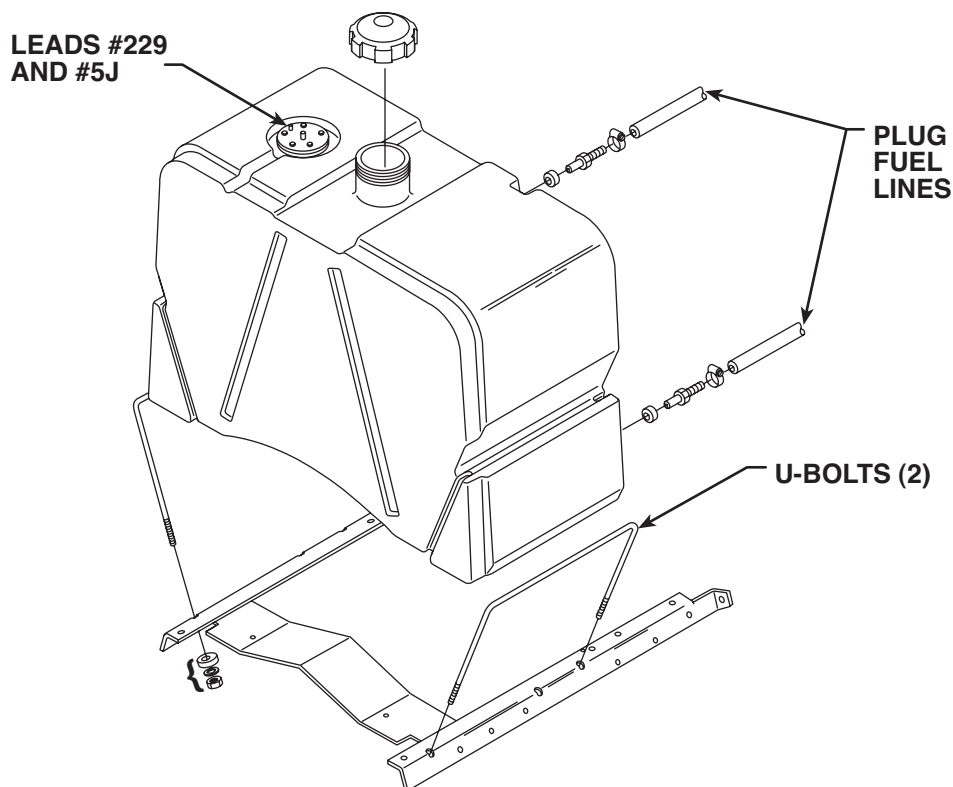

PROCEDURE

1. Turn the engine off.
2. Perform the **Case Cover Removal Procedure**, including the output panel.
3. Perform the **Output Rectifier Bridge and Choke Removal Procedure**.
4. Using a 3/8" wrench, remove leads #229 (white) and #5J from the fuel level sensor. See Figure F.19. Label the leads for reassembly.
5. Turn the fuel off at the shutoff valve. Remove and plug the fuel return line. See Figure F.19.
6. Remove and plug the lower fuel line. Pull it through the firewall. See Figure F.19.
7. Using a 9/16" socket wrench, remove the four lock nuts, washers, and rubber washers from the fuel tank mounting U-bolts. See Figure F.19.
8. Carefully remove the U-bolts and lift the fuel tank from the machine.

STATOR/ROTOR REMOVAL AND REPLACEMENT PROCEDURE (CONTINUED)

FIGURE F.20 – PLUG AND LEAD REMOVAL

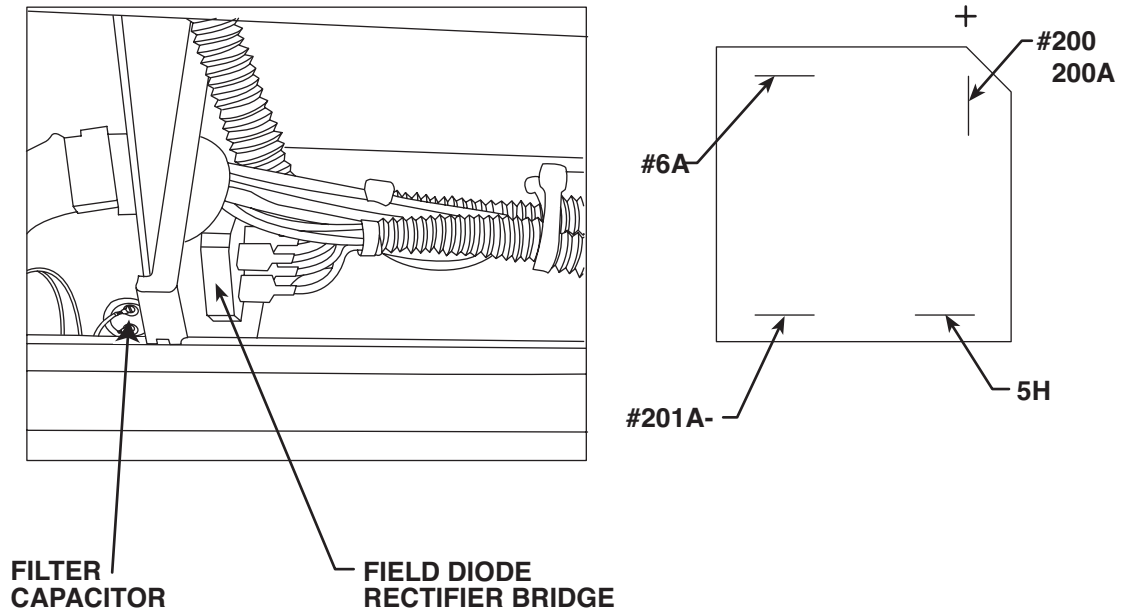

PROCEDURE

9. Disconnect plug J30 at the right front side. See Figure F.20.
10. Using the slot head screw driver, disconnect leads #200B, #200A(+) and #201A(-) from the filter capacitor. Label the leads.
11. Label and remove leads 5H, 200, 200A, 6A, 201A, 5H from the field bridge rectifier. See Figure F.20.

STATOR/ROTOR REMOVAL AND REPLACEMENT PROCEDURE (CONTINUED)

FIGURE F.21 – BRUSHHOLDER LEAD REMOVAL

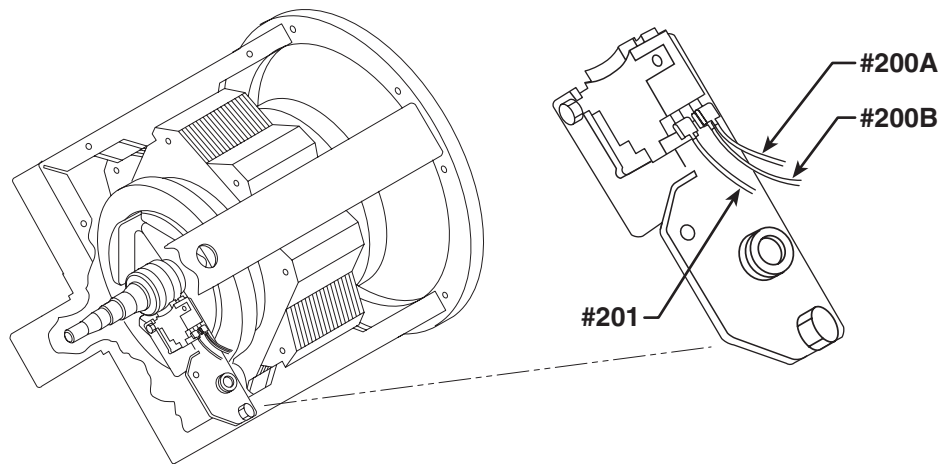

PROCEDURE

12. Label and remove brush leads #201(-) and #200B(+) from the brush holder assembly. (The Piggy-backed leads connect closest to the stator terminations.) See Figure F.21.
13. Pull the harness containing plug J30, the brush leads, and the field bridge rectifier through the bushing in the firewall. See **Figure F.20**.
14. Using a 3/8" wrench, remove the brush holder assembly.
15. Using the 1/2" wrench, disconnect leads #68A and #69A at their bolted connections beneath the power module assembly. Label the leads for reassembly. Cut any necessary cable ties. See **Figure F.22**.

STATOR/ROTOR REMOVAL AND REPLACEMENT PROCEDURE (CONTINUED)

FIGURE F.22 – CONTROL & OUTPUT PANELS - REAR VIEW

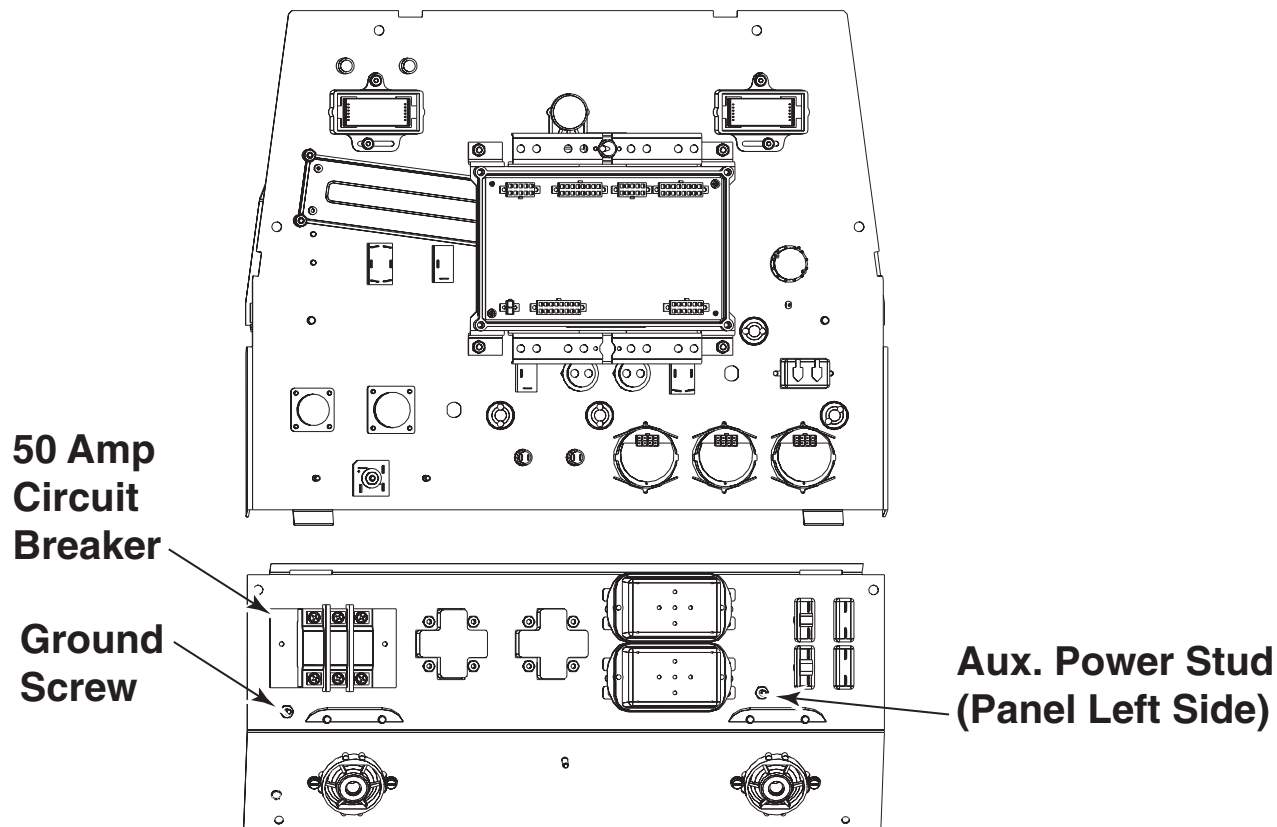

16. Using a 7/16" wrench, disconnect stator lead #6 from the auxiliary power stud on the left side of the control box. See Figure F.22.

17. With a 3/8" wrench, disconnect lead #5 from the center ground stud (nearest the control transformer). See Figure F.22.

18. Using a phillips screw driver, remove lead #3 from the top 50A circuit breaker for the 120/240V receptacle. See Figure F.22.

NOTE: This lead must be wound two turns clockwise through the toroid (opposite in direction from leads #6A).

19. Disconnect lead #5A from the auxiliary power ground stud (left side of the control box, next to the 120V circuit breaker). See Figure F.22.

20. Using a 3/8" wrench, remove the two screws holding the control box to the top of the fan baffle.

STATOR/ROTOR REMOVAL AND REPLACEMENT PROCEDURE (CONTINUED)

FIGURE F.23 – LIFT FRAME REMOVAL

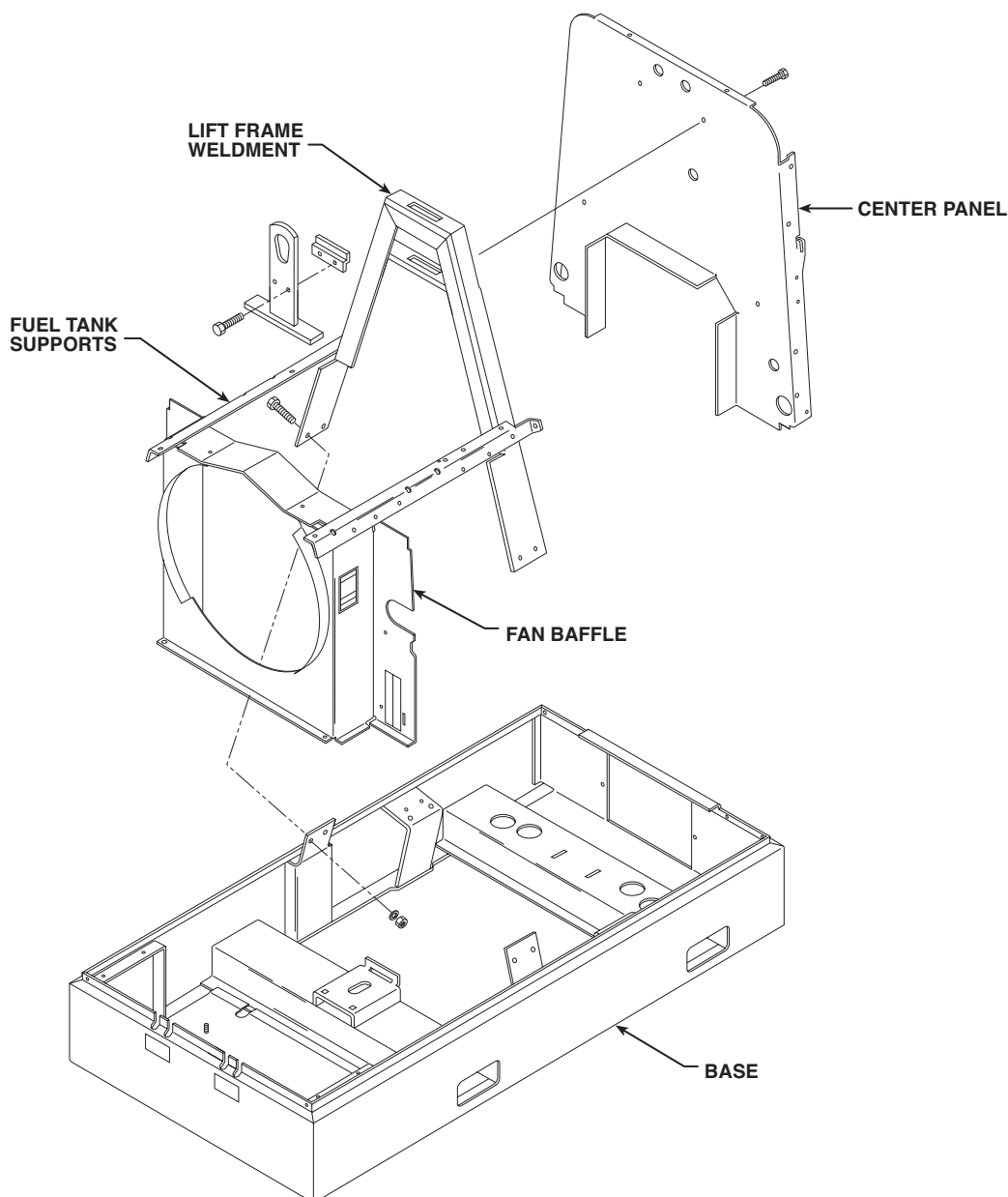

In steps 21 - 25, the lift frame weldment, fuel tank supports, and fan baffle are removed as a unit. See Figure F.23.

21. Using a 3/8" wrench, remove the two bolts (at top) that hold the firewall to the lift frame weldment.
22. Using a 1/2" wrench, remove the two bolts (at bottom) that hold the firewall to the lift frame weldment.
23. With a 3/8" wrench, remove the nuts, lock washers, and flat washers from the two studs that hold the fan baffle to the machine base.

24. Using a 3/4" wrench, remove the four bolts, lock washers, and nuts from the bottom of the lift frame weldment.

25. Carefully remove the lift frame weldment, fuel tank supports, and attached fan baffle. You will need to lift the fan baffle off the two studs on the machine base, then cock it slightly to remove it.

STATOR/ROTOR REMOVAL AND REPLACEMENT PROCEDURE (CONTINUED)

FIGURE F.24 – STATOR REMOVAL

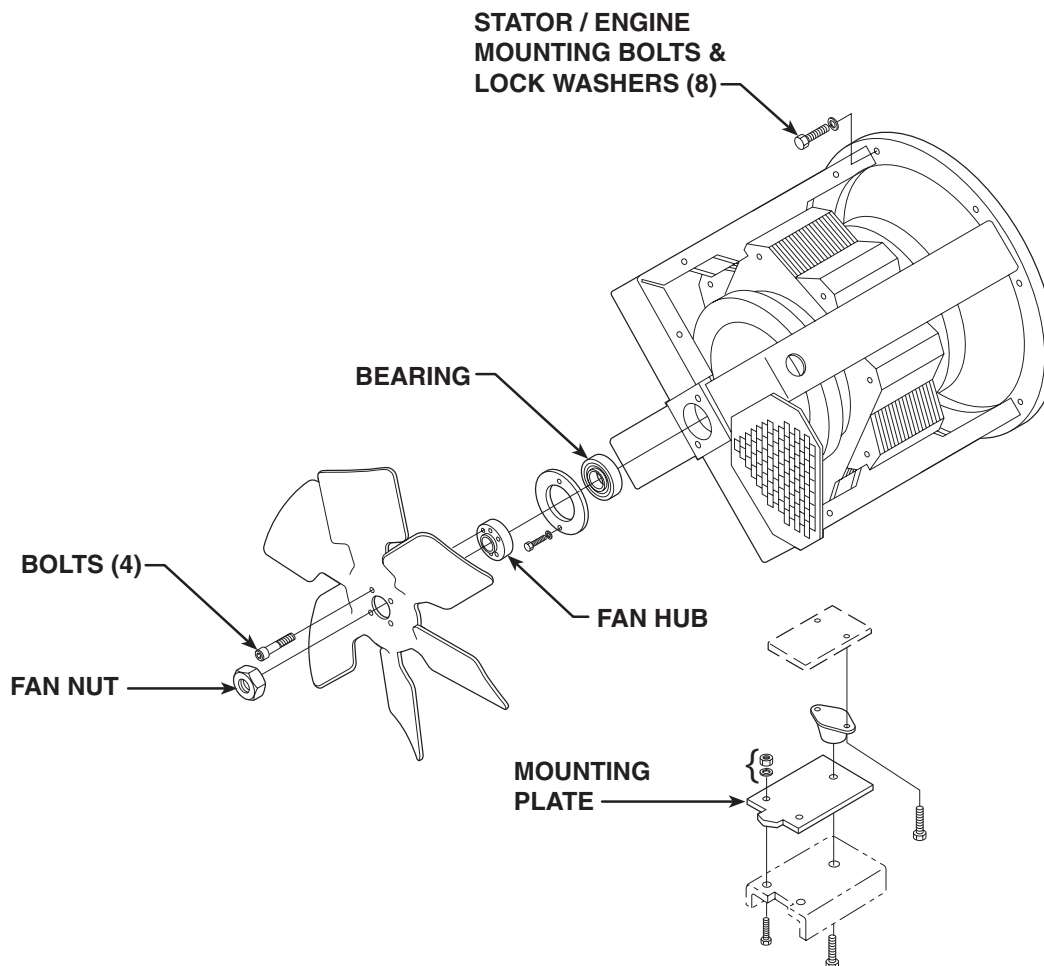

STATOR REMOVAL PROCEDURE

1. Using a 1/2" wrench, remove the four fan blade mounting bolts and lock washers. See Figure F.24.
2. Using a 1 1/8" wrench, remove the fan nut. Remove the fan, noting the direction for reassembly.
3. Using the gear puller, remove the fan hub.
4. Using a 3/8" wrench, remove the two bolts and flat washers holding the bearing in place.
5. Using a 1/2" wrench, remove the two nuts, lock washers, and carriage bolts holding the generator mounting plate to the machine base.
6. Support the stator with a hoist. Place wooden blocks under the engine to support it when the stator is removed.
7. Using a 9/16" wrench, remove the eight bolts and lock washers holding the stator to the engine.
8. Remove the stator from the engine. It may be necessary to pry and slide it free.

STATOR/ROTOR REMOVAL AND REPLACEMENT PROCEDURE (CONTINUED)

FIGURE F.25 – ROTOR REMOVAL

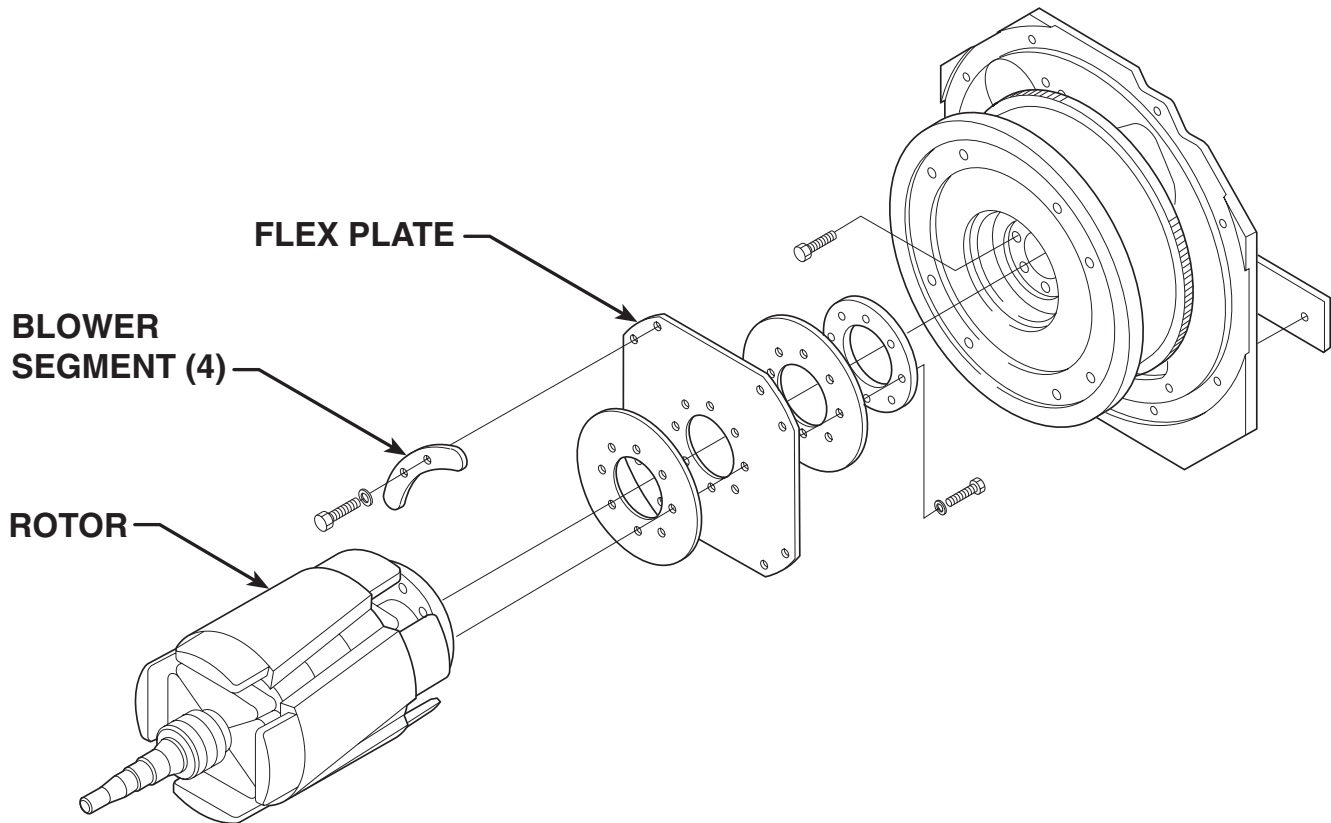

ROTOR REMOVAL PROCEDURE

1. Support the rotor with a hoist.
2. Using a 5/16" wrench, remove the flex plate bolts, lock washers, and four blower segments. See Figure F.25.

⚠ WARNING

The rotor will be free to fall when the bolts are removed.

3. Using the hoist, carefully remove the rotor and flex plate assembly.

REASSEMBLY NOTES

Reassemble the rotor and stator to the Vantage® 400 by carefully retracting the disassembly procedure steps in reverse order. Keep the following special points in mind as you proceed.

1. **INSTALL ROTOR:** Support the rotor with the hoist. Install the blower segments and flex plate to the engine flywheel.
2. **INSTALL STATOR:** Be sure the engine is blocked securely and the stator is supported by the hoist. Install the stator to the engine with the eight bolts and lock washers. Install the fan blade, making sure that it faces the proper direction, with the fan nut and four cap screws.
3. Check the air gap for .012" minimum.

STATOR/ROTOR REMOVAL AND REPLACEMENT PROCEDURE (CONTINUED)

FIGURE F.29 – ROTOR REMOVAL & REPLACEMENT

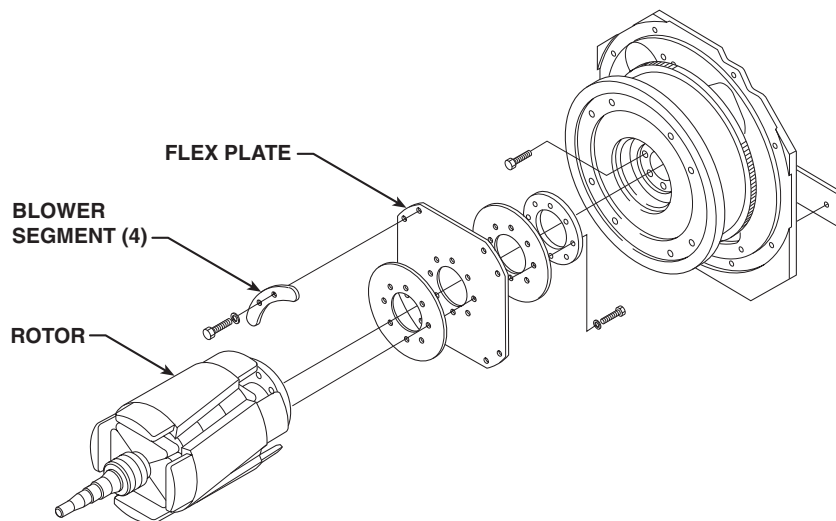

PROCEDURE

1. Remove the screws and disc clamping bars from the rotor coupling disc, and remove the rotor.

NOTE: Earlier machines used three 0.31" thick clamping bars and later models use six 0.14" thick clamping bars arranged in three sets of two bars each.

If the rotor is to be replaced, remove the screws, rotor clamping ring and coupling disc from the rotor hub.

Replacing the Rotor

1. Whenever the rotor and stator are separated, it is highly recommended that a new bearing and tolerance ring be installed when the rotor and stator are reassembled.
2. Examine the rotor, coupling disc, clamping ring, clamping bars, screws, lock washers, and the engine flywheel. Make sure that all of the parts are clean and in good condition.
3. Install a new bearing on the rotor shaft.
4. Assemble the coupling disc and clamping ring to the rotor hub. The surface of the disc with the stamping burrs should be against the rotor hub. The side of the clamping ring with the radius should be placed against the coupling disc. See Figure F.29.
5. Insert the screws with lock washers and evenly tighten to a torque of 17 to 19 Ft-Lbs.
6. Lift the rotor assembly with the hoist and lifting straps and recheck the engine flywheel and coupling disk for anything that might prevent proper seating.
7. To attach the coupling disk to the engine flywheel, align the screw holes and insert the six screws, with lock washers, through the disc clamping bars and the coupling disc and into the engine flywheel.
8. Evenly tighten all the screws to a torque of 17 to 19 Ft-Lbs.

RETEST AFTER REPAIR

Retest a machine:

- If it is rejected under test for any reason that requires you to remove any mechanical part which could affect the machine's electrical characteristics. OR
- If you repair or replace any electrical components.

ENGINE OUTPUT

Mode	No Load RPM	Load RPM
Low Idle	1300 - 1400	N/A
High Idle	1860 - 1890	1800

WELDER DC (STICK) OUTPUT (ARC control @ -10)

Mode Selector Switch	Output Control	Open Circuit Volts	Load Volts	Load Amps
Stick (CC)	Maximum	55-60	36-38	400

WELDER CV (WIRE) OUTPUT (ARC Control @ +10)

Mode Selector Switch	Output Control	Open Circuit Voltage	Load Volts	Load Amps
CV	Maximum	55-60	36-38	290-310
CV	Minimum	55-60	17-19	220

TOUCH START TIG (ARC Control @ +10)

Mode Selector Switch	Output Control	Open Circuit Voltage	Load Volts	Load Amps
TIG	Maximum	10-15	18-22	240-260
TIG	Minimum	10-15	Short Circuit	18-28

AUXILIARY POWER OUTPUT

240 Volt Receptacle			120 Volt Receptacles		
Open Circuit Voltage	Load Volts	Load Amps	Open Circuit Voltage	Load Volts	Load Amps
230-264*	216-252	50	115-132	108-126	20

* Upper limit reflects cold machine, voltage will be below 132/264 for machine at normal operating temperature.

42 VOLT WIRE FEEDER POWER

Open Circuit Voltage	Load Volts	Load Amps
40-50	38-48	8.5

Electrical Diagrams	G-1
Wiring Diagram - Complete Machine (G5481)	G-2
Schematic – Complete Machine (G5597 Page 1)	G-3
Schematic – Complete Machine (G5597 Page 2)	G-4
Schematic – Weld Control PC Board – (G5506 Page 1)*	G-5
Schematic – Weld Control PC Board – (G5506 Page 2)*	G-6
Schematic – Weld Control PC Board – (G5506 Page 3)*	G-7
Schematic – Weld Control PC Board – (G5506 Page 4)*	G-8
Schematic – Weld Control PC Board – (G5506 Page 5)*	G-9
Schematic – Idler PC Board (G4828-2)*	G-10
Schematic – Chopper PC Board (L12717-1C0)*	G-11
Schematic – OCV Indicator PC Board (G4406-2D0)*	G-12
Schematic – By Pass / Stabilizer PC Board (S22530-3D0)	G-13
PC Board Assembly – By Pass / Stabilizer PC Board (L10121-3)	G-14
Wiring Diagram - Complete Machine (G7138 Codes 11785, 11920)	G-15
Schematic - Complete Machine (G6379 Codes 11785, 11920)	G-16

*** NOTE:** Many PC Board Assemblies are now totally encapsulated, surface mounted and or multi-layered and are therefore considered to be unserviceable. Assembly drawings of these boards are no longer provided.

WIRING DIAGRAM - COMPLETE MACHINE - (G5481)

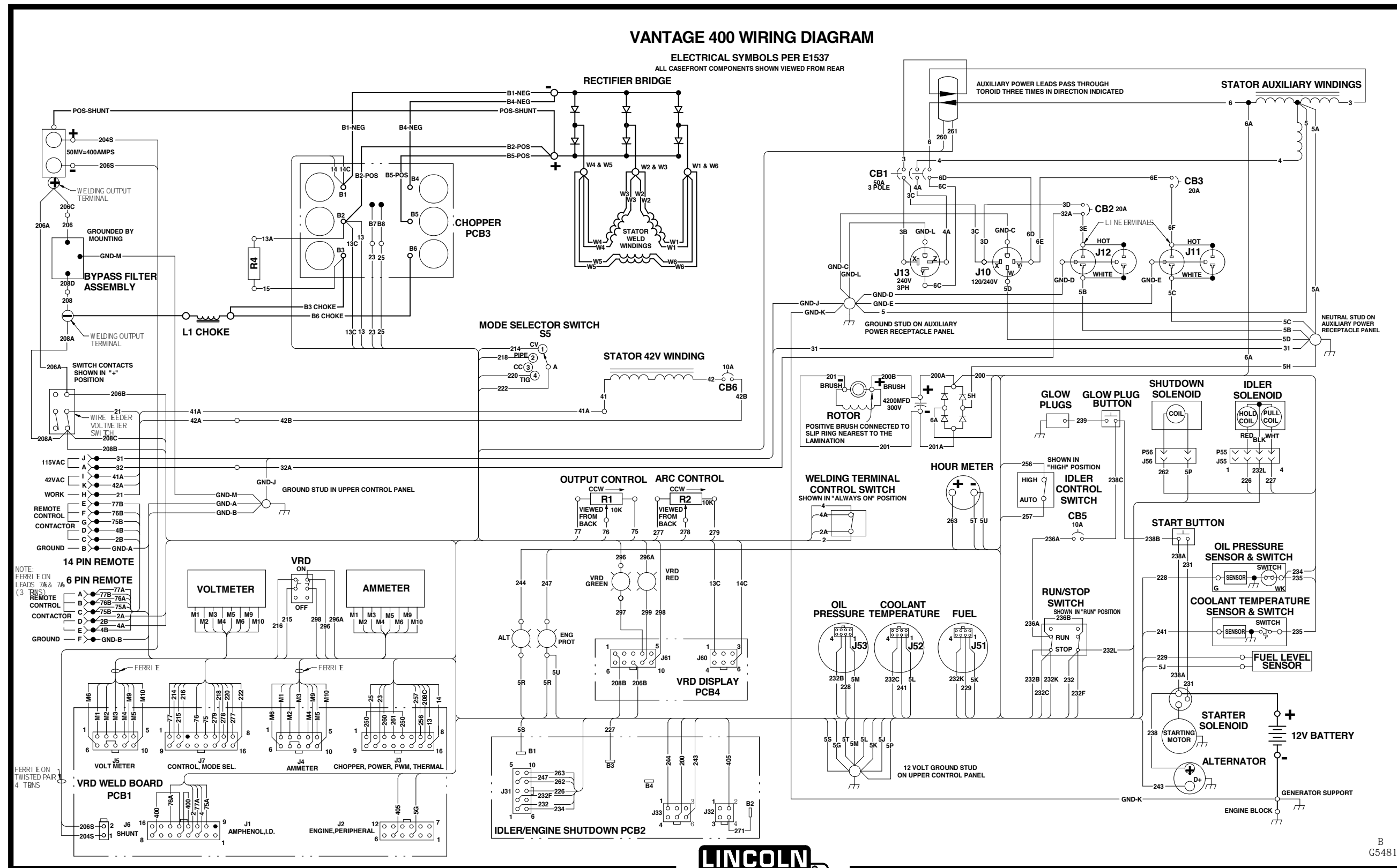

NOTE: This diagram is for reference only. It may not be accurate for all machines covered by this manual. The wiring diagram specific to your code is pasted inside one of the enclosure panels of your machine.

SCHEMATIC - COMPLETE MACHINE - (G5597 PAGE 1)

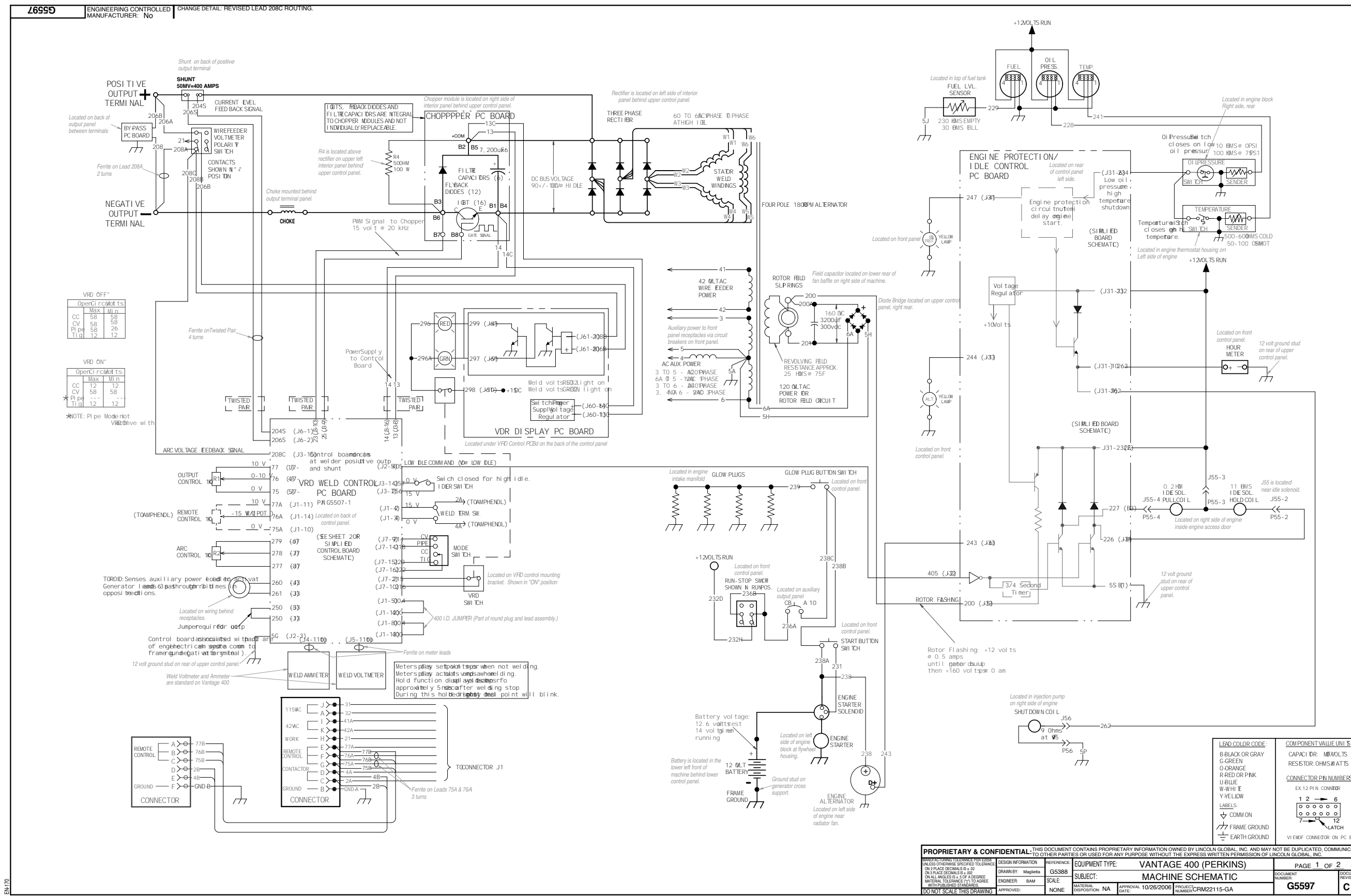

NOTE: This diagram is for reference only. It may not be accurate for all machines covered by this manual.



Return to Section TOC
Return to Section TOC
Return to Section TOC
Return to Section TOC
Return to Section TOC
Return to Section TOC
Return to Section TOC
Return to Section TOC

Return to Master TOC
Return to Master TOC
Return to Master TOC
Return to Master TOC
Return to Master TOC
Return to Master TOC
Return to Master TOC
Return to Master TOC

PROPRIETARY & CONFIDENTIAL: THIS DOCUMENT CONTAINS PROPRIETARY INFORMATION OWNED BY LINCOLN GLOBAL, INC. AND MAY NOT BE DUPLICATED, COMMUNICATED TO OTHER PARTIES OR USED FOR ANY PURPOSE WITHOUT THE EXPRESS WRITTEN PERMISSION OF LINCOLN GLOBAL, INC.

DESIGN INFORMATION	REFERENCE	EQUIPMENT TYPE	VANTAGE 400 (PERKINS)	PAGE 1 OF 2
DESIGNER: Maghitta	G5388	SUBJECT:	MACHINE SCHEMATIC	DOCUMENT NUMBER: G5597
ENGINEER: BAM	SCALE: NONE	MATERIAL DISPOSITION: NA	APPROVAL: 10/26/2006	PROJECT NUMBER: CRM22115-GA
APPROVED:				DOCUMENT REVISION: C

LEAD COLOR CODE:

- B BLACK OR GRAY
- G GREEN
- O ORANGE
- R RED OR PINK
- U BLUE
- W WHITE
- Y YELLOW

LABELS:

- COM ON
- FRAME GROUND
- EARTH GROUND

CONNECTOR PIN NUMBERS:

EX 12 PIN CONNECTOR

1	2	3	4	5	6
7	8	9	10	11	12

VIEW OF CONNECTOR ON PC BOARD

COMPONENT VALUE UNITS:

- CAPACITOR: M/MOLTS
- RESISTOR: OHMS/W ATTS

SCHEMATIC - COMPLETE MACHINE - (G5597 PAGE 2)

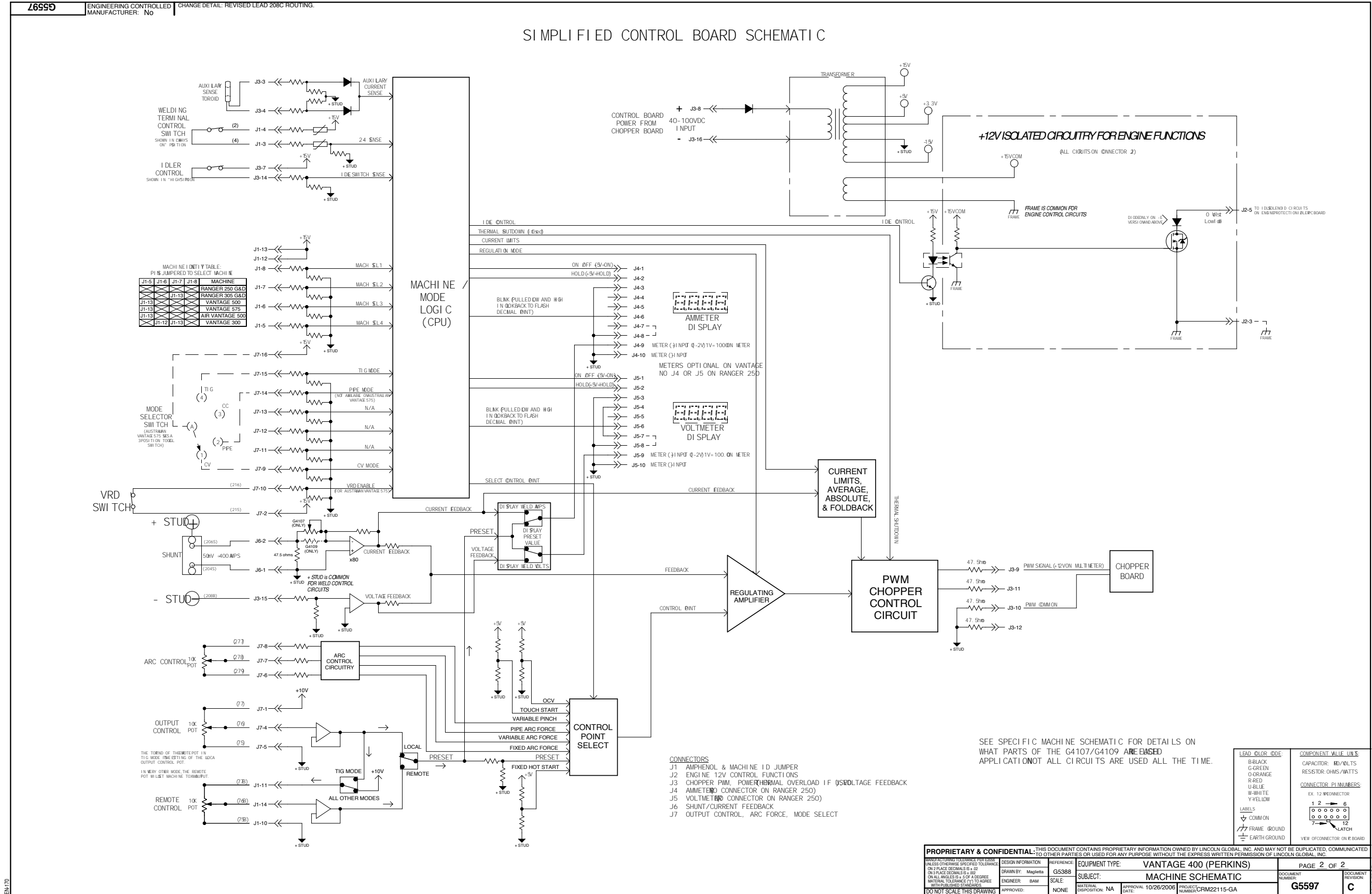

NOTE: This diagram is for reference only. It may not be accurate for all machines covered by this manual.

SCHEMATIC - WELD CONTROL PC BD. (G5506 PAGE 1 OF 5)

Return to Section TOC
Return to Master TOC

Return to Section TOC
Return to Master TOC

Return to Section TOC
Return to Master TOC

Return to Section TOC
Return to Master TOC

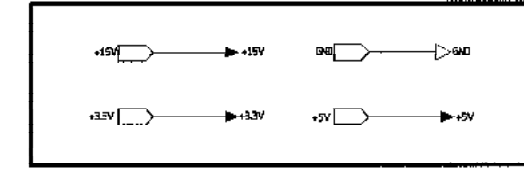
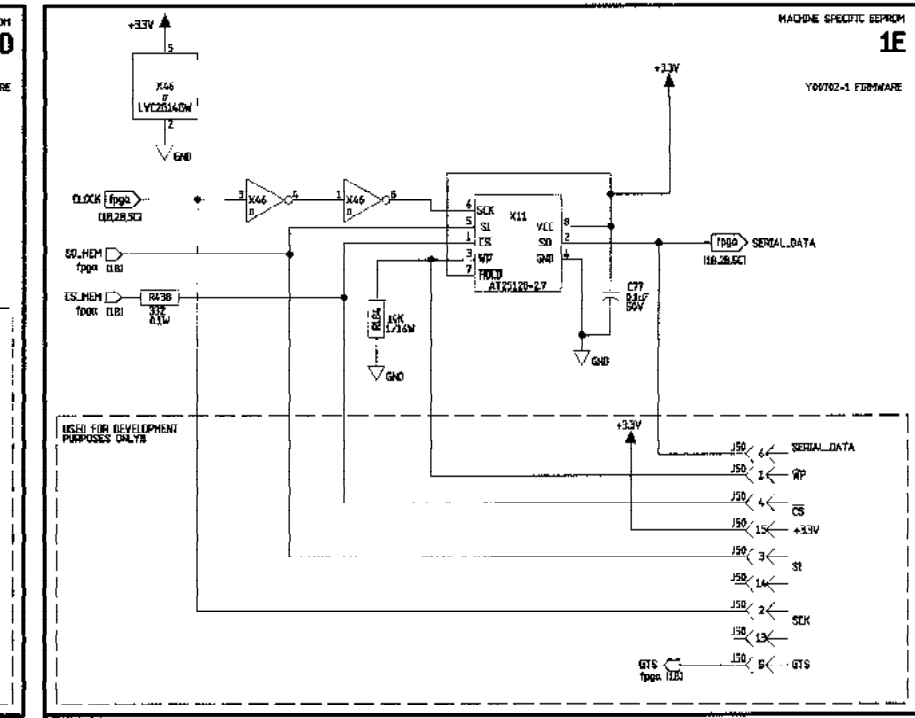
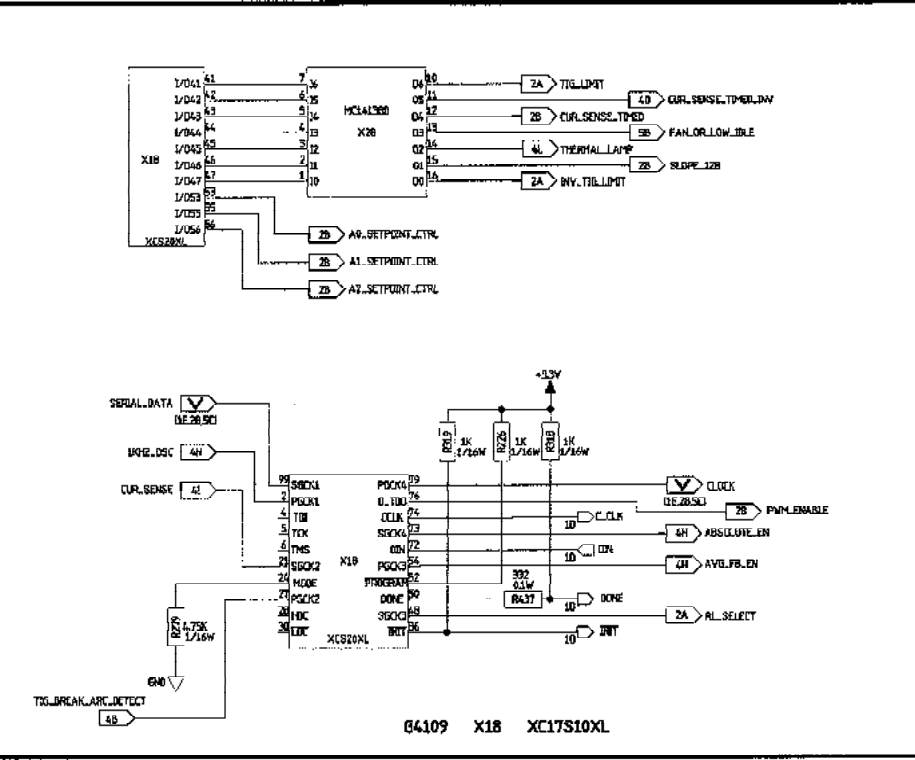
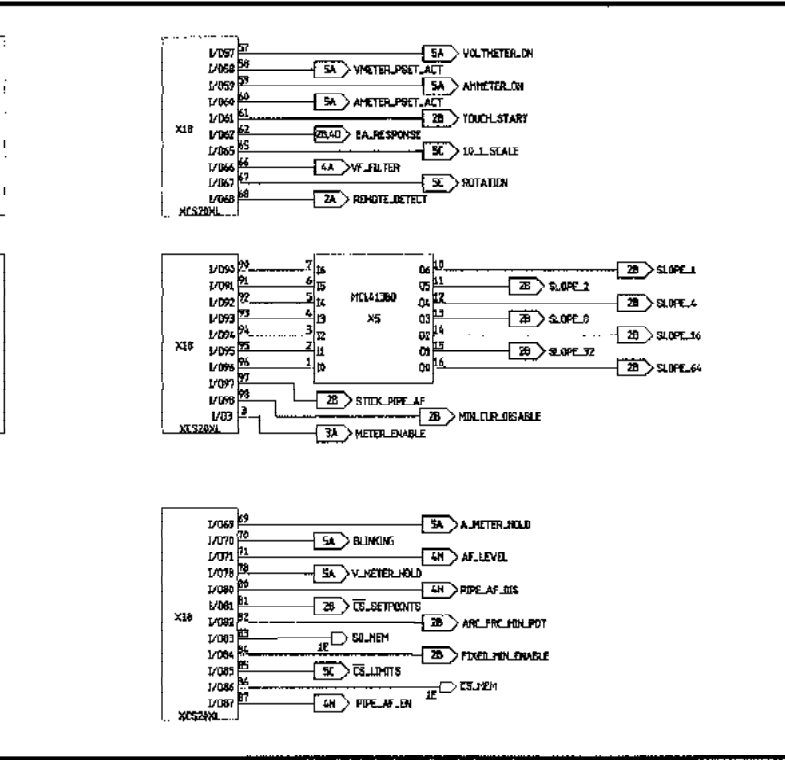
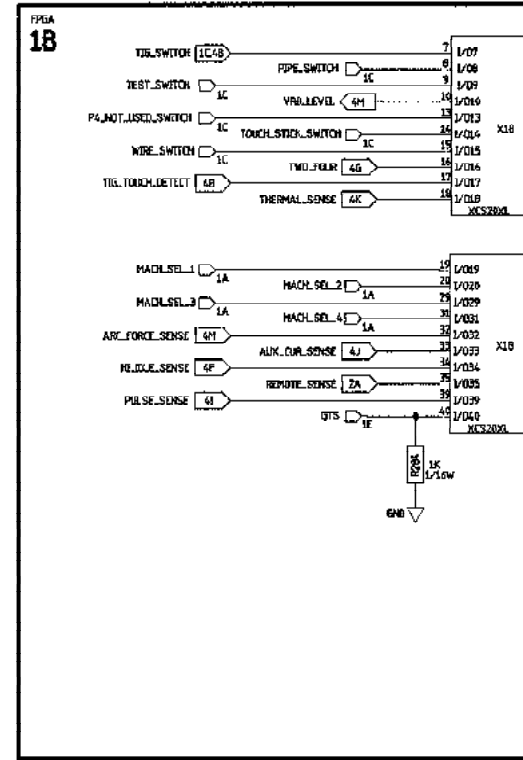
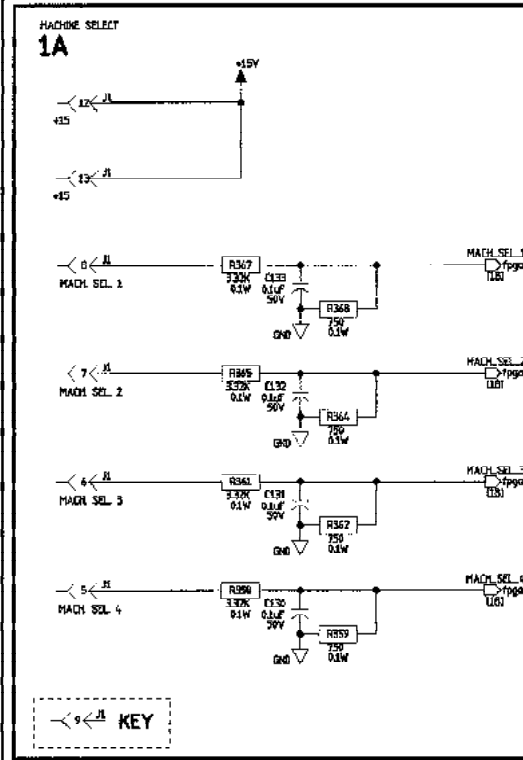

GENERAL INFORMATION

ELECTRICAL SYMBOLS PER IEEE37
CAPACITORS - MFD (422/50V) UNLESS OTHERWISE SPECIFIED
RESISTORS - OHMS (600) UNLESS OTHERWISE SPECIFIED
DIMENSIONS - IN UNLESS OTHERWISE SPECIFIED

LABELS

- ▲ SUPPLY VOLTAGE NET
- POWER SUPPLY SOURCE POINT
- ▽ COMMON CONNECTION
- FRAME CONNECTION
- ⊕ EARTH GROUND CONNECTION

—THIS SCHEMATIC USED IN G4109 AND G5109 BOARDS—

PROPRIETARY & CONFIDENTIAL THIS DOCUMENT CONTAINS PROPRIETARY INFORMATION OWNED BY LINCOLN GLOBAL, INC. AND MAY NOT BE REPLICATED, COPIED, OR DISSEMINATED TO ANY PARTY OR USED FOR ANY PURPOSE WITHOUT THE EXPRESS WRITTEN PERMISSION OF LINCOLN GLOBAL, INC.

DESIGN INFORMATION DRAWN BY: RLS/PJL ENGINEER: APH APPROVED: [Signature]	REFERENCE TO NOT SCALE THIS DRAWING	EQUIPMENT TYPE: COMMON ANALOG CONTROLS SUBJECT: SCHEMATIC, ANALOG CONTROL PCB MATERIAL DISPOSITION: NA DATE: 9/15/2006 PROJECT NUMBER: CRP07943-B	PAGE 01 OF 05 DOCUMENT NUMBER: G5506-ZL0 DOCUMENT REVISION: A
---	--	---	---

NOTE: This diagram is for reference only. It may not be accurate for all machines covered by this manual.



SCHEMATIC - WELD CONTROL PC BD. (G5506 PAGE 2 OF 5)

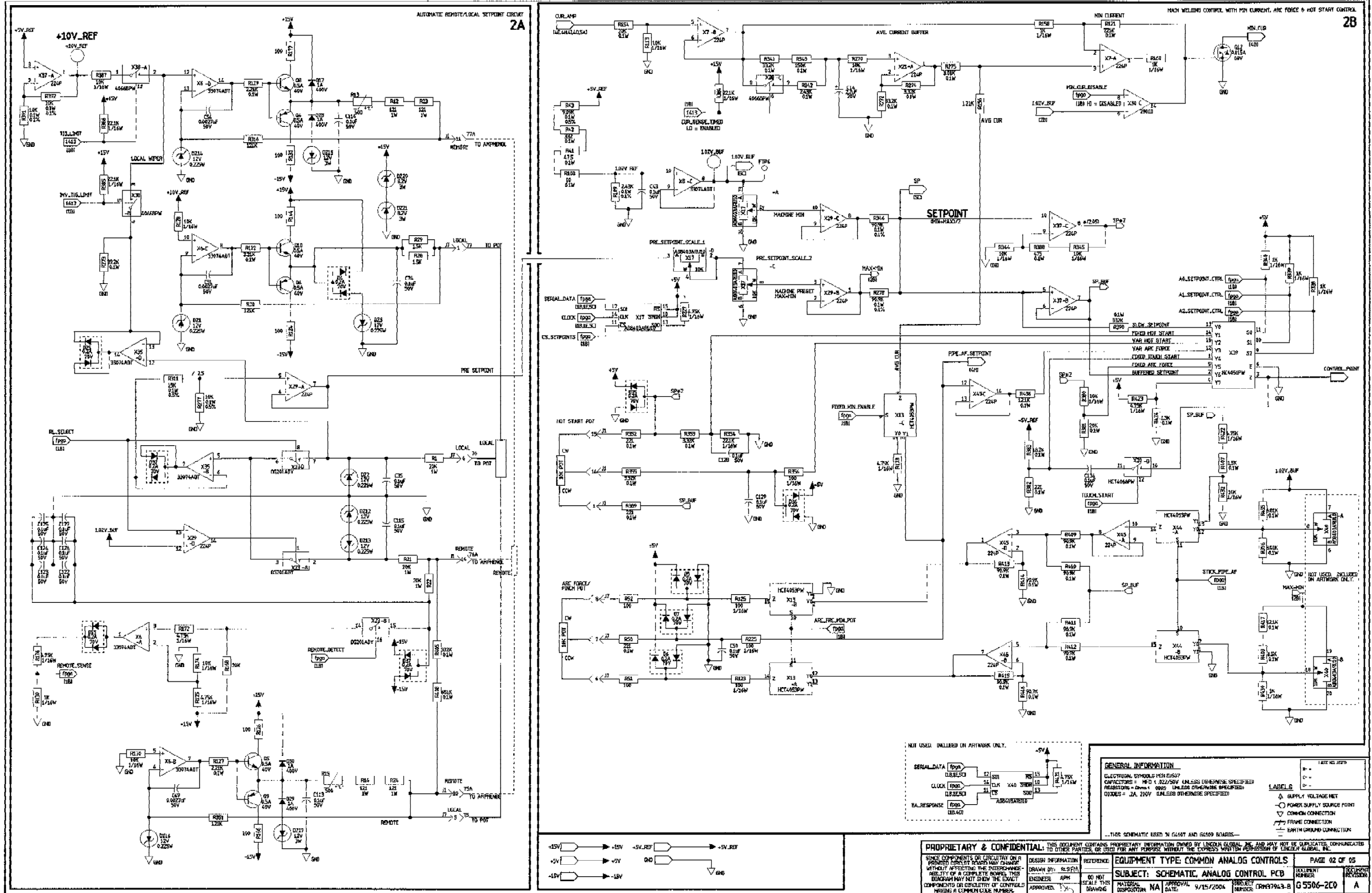

NOTE: This diagram is for reference only. It may not be accurate for all machines covered by this manual.

SCHEMATIC - WELD CONTROL PC BD. (G5506 PAGE 3 OF 5)

Return to Section TOC
Return to Master TOC

Return to Section TOC
Return to Master TOC

Return to Section TOC
Return to Master TOC

Return to Section TOC
Return to Master TOC

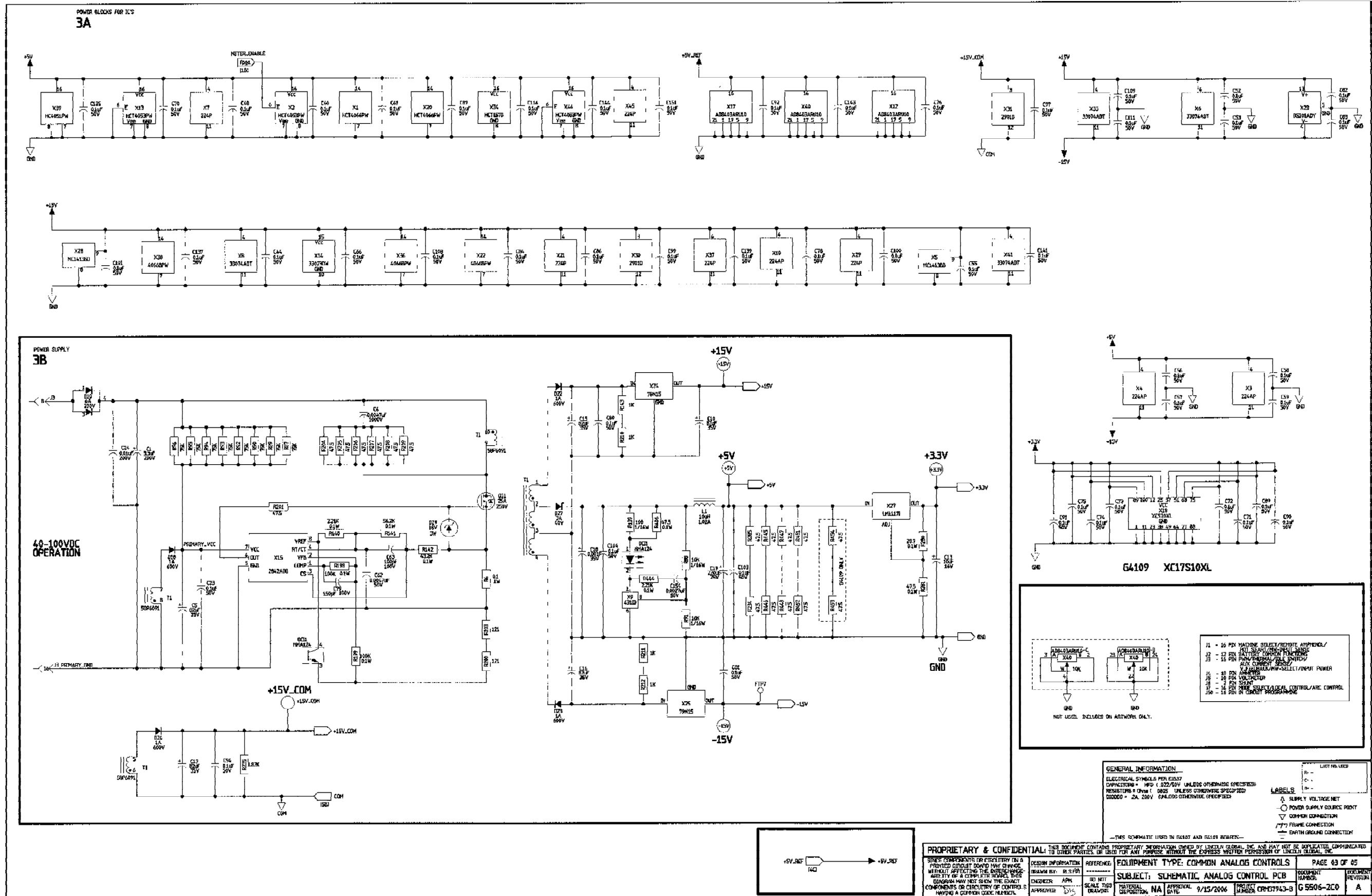

NOTE: This diagram is for reference only. It may not be accurate for all machines covered by this manual.

SCHEMATIC - WELD CONTROL PC BD. (G5506 PAGE 4 OF 5)

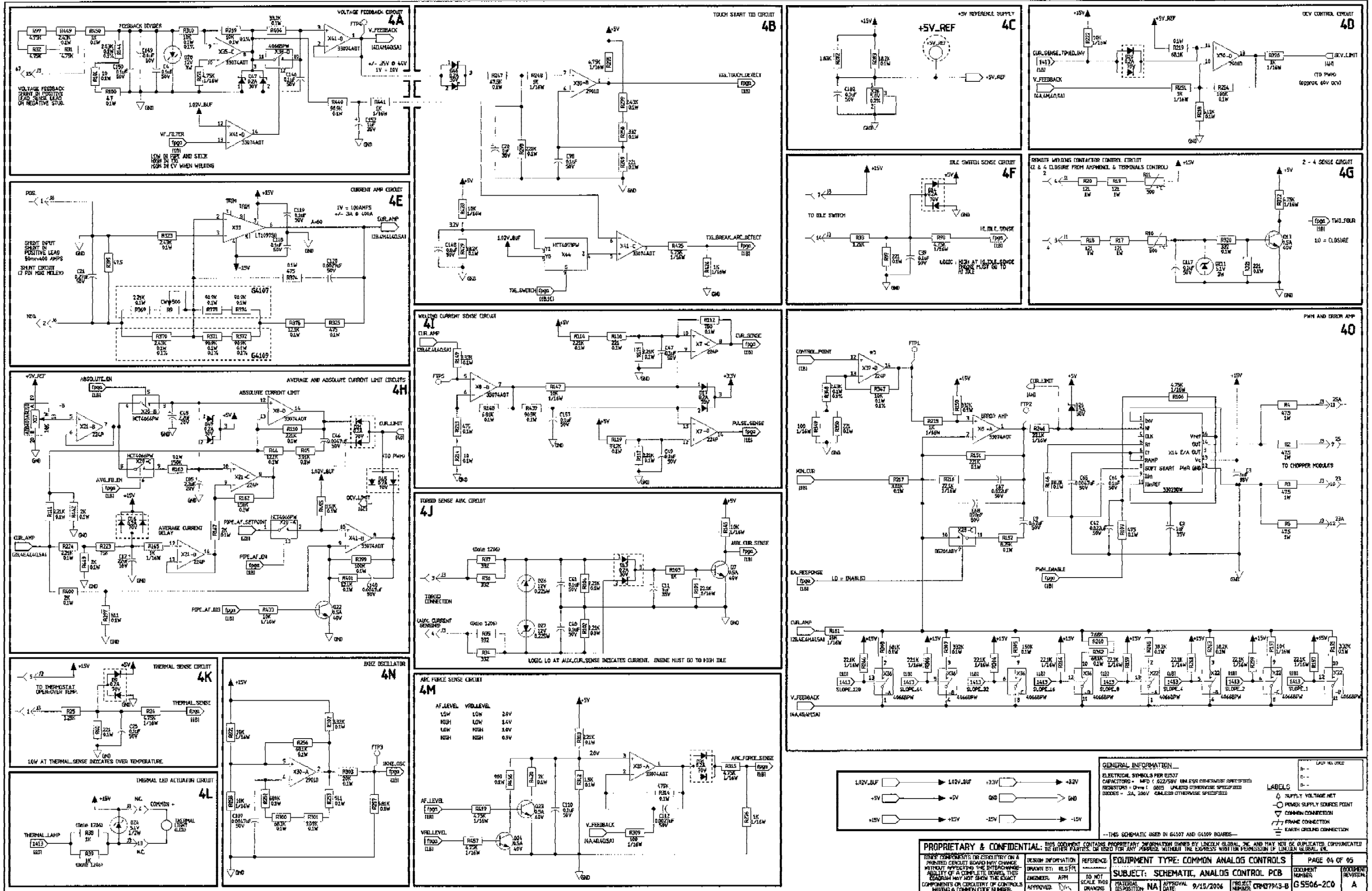

NOTE: This diagram is for reference only. It may not be accurate for all machines covered by this manual.

SCHEMATIC - WELD CONTROL PC BD. (G5506 PAGE 5 OF 5)

Return to Section TOC

Return to Section TOC

Return to Section TOC

Return to Section TOC

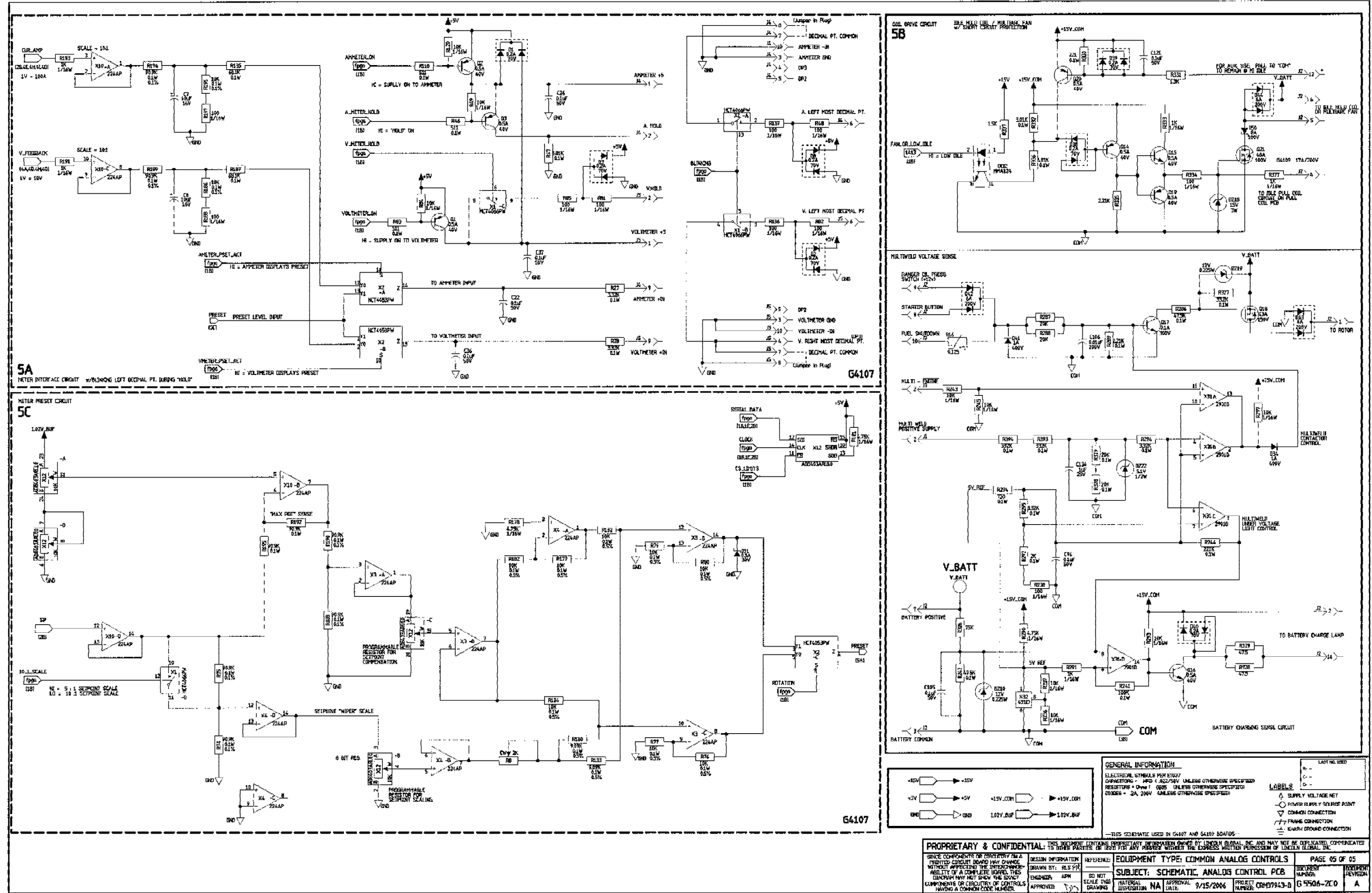

NOTE: This diagram is for reference only. It may not be accurate for all machines covered by this manual.

SCHEMATIC - IDLER PC BD (G4828-2)

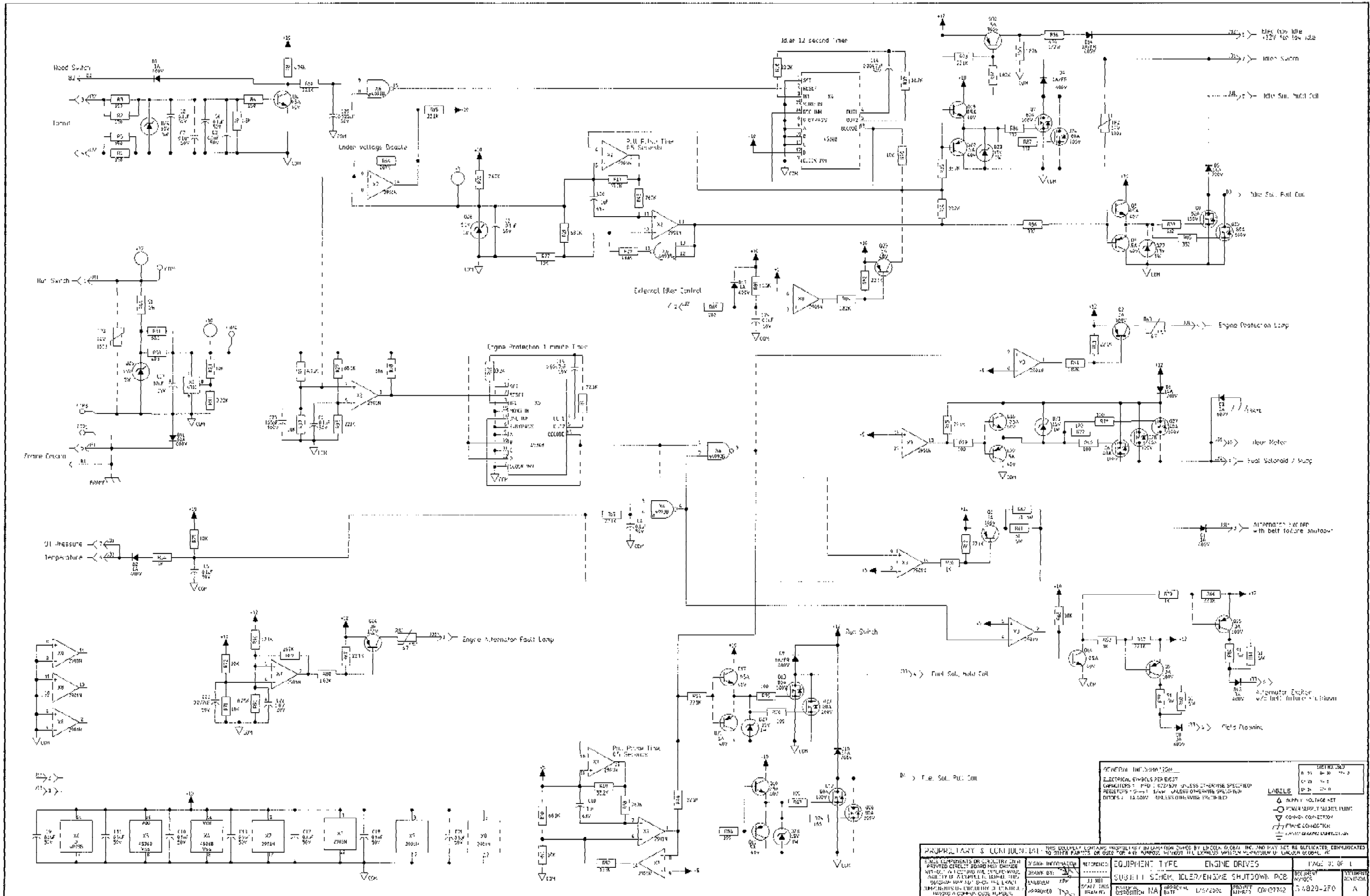

NOTE: This diagram is for reference only. It may not be accurate for all machines covered by this manual.

Return to Section TOC / Return to Master TOC

SCHEMATIC - CHOPPER PC BD (L12717-1CO)

Return to Section TOC
Return to Master TOC

Return to Section TOC
Return to Master TOC

Return to Section TOC
Return to Master TOC

Return to Section TOC
Return to Master TOC

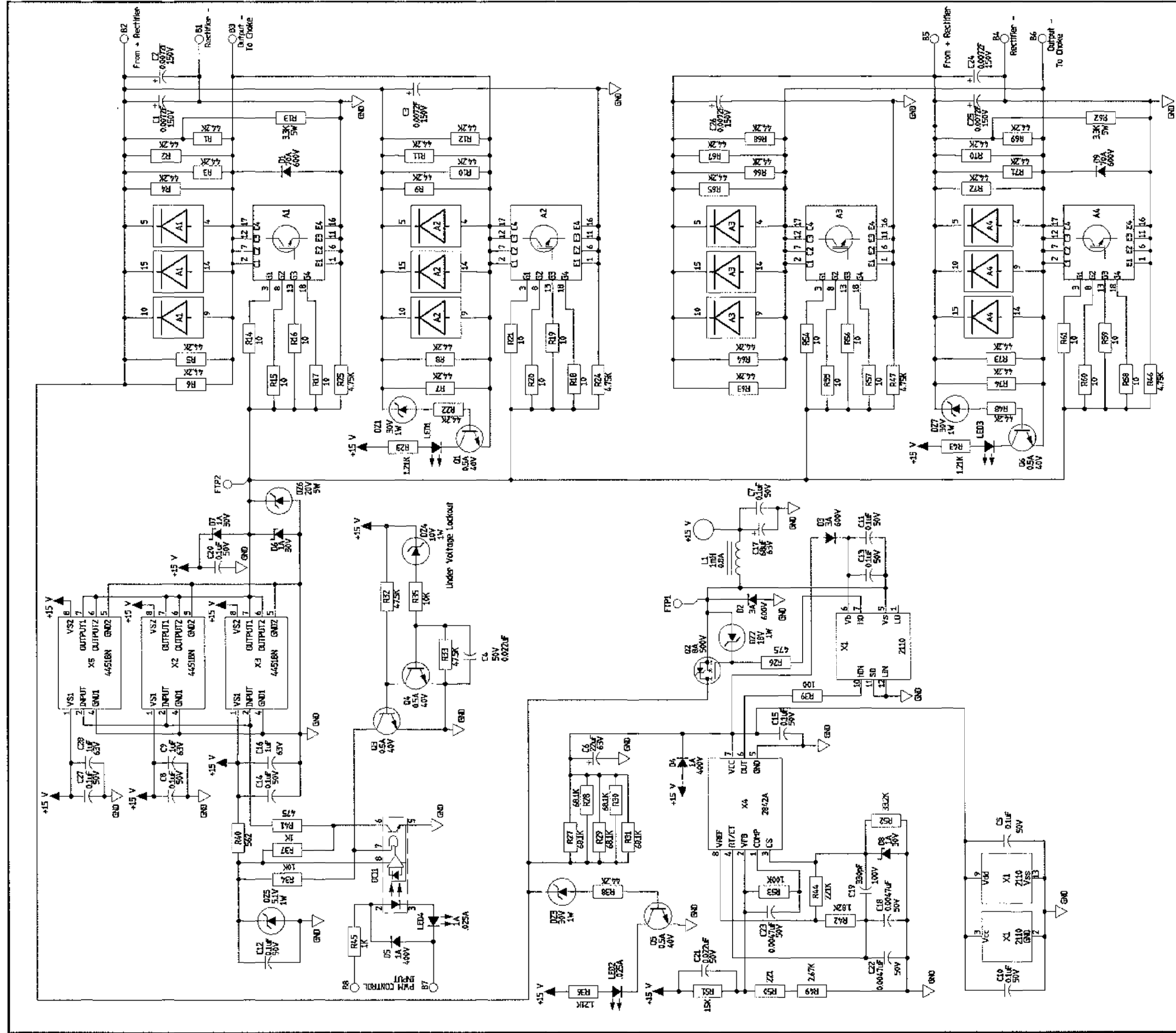

GENERAL INFORMATION
 ELECTRICAL SYMBOLS PER EIA-7
 CAPACITORS = 100P/50V UNLESS OTHERWISE SPECIFIED
 RESISTORS = 0.5W/1/4W UNLESS OTHERWISE SPECIFIED
 DIODES = 1A/600V UNLESS OTHERWISE SPECIFIED

LABELS
 A SUPPLY VOLTAGE NET
 ○ COMMON CONNECTION
 □ FRAME CONNECTION
 ⊕ EARTH GROUND CONNECTION

LAST NO. USED
 R-19 X-4 A-4 LED-4
 C-20 Q-6 L-1 D-8
 D-9 QZ-7 QZ-1 P10-2

PROPRIETARY & CONFIDENTIAL - THIS DOCUMENT CONTAINS PROPRIETARY INFORMATION OWNED BY LINCOLN GLOBAL, INC. AND MAY NOT BE DUPLICATED, COMMUNICATED OR DISCLOSED TO OTHER PARTIES, OR USED FOR ANY PURPOSE WITHOUT THE EXPRESS WRITTEN PERMISSION OF LINCOLN GLOBAL, INC.	
DESIGN INFORMATION DRAWN BY: MAG	REFERENCE: CHOPPERS
ENGINEER: ES/RS	EQUIPMENT TYPE: SCHEMATIC, 500 CHOPPER PCB
APPROVED:	PROJECT NUMBER: L12717-1CO
HAVING A DESIGN CODE NUMBER	DATE: 11/3/2005
SCALE: THIS DRAWING IS APPROVED	DISPOSITION: NA
DO NOT SCALE THIS DRAWING	APPROVAL DATE: NA
REVISION NUMBER	REVISION
1	A

NOTE: This diagram is for reference only. It may not be accurate for all machines covered by this manual.

SCHEMATIC -OCV INDICATOR PC BD (G4406-2D0)

Return to Section TOC
Return to Master TOC

Return to Section TOC
Return to Master TOC

Return to Section TOC
Return to Master TOC

Return to Section TOC
Return to Master TOC

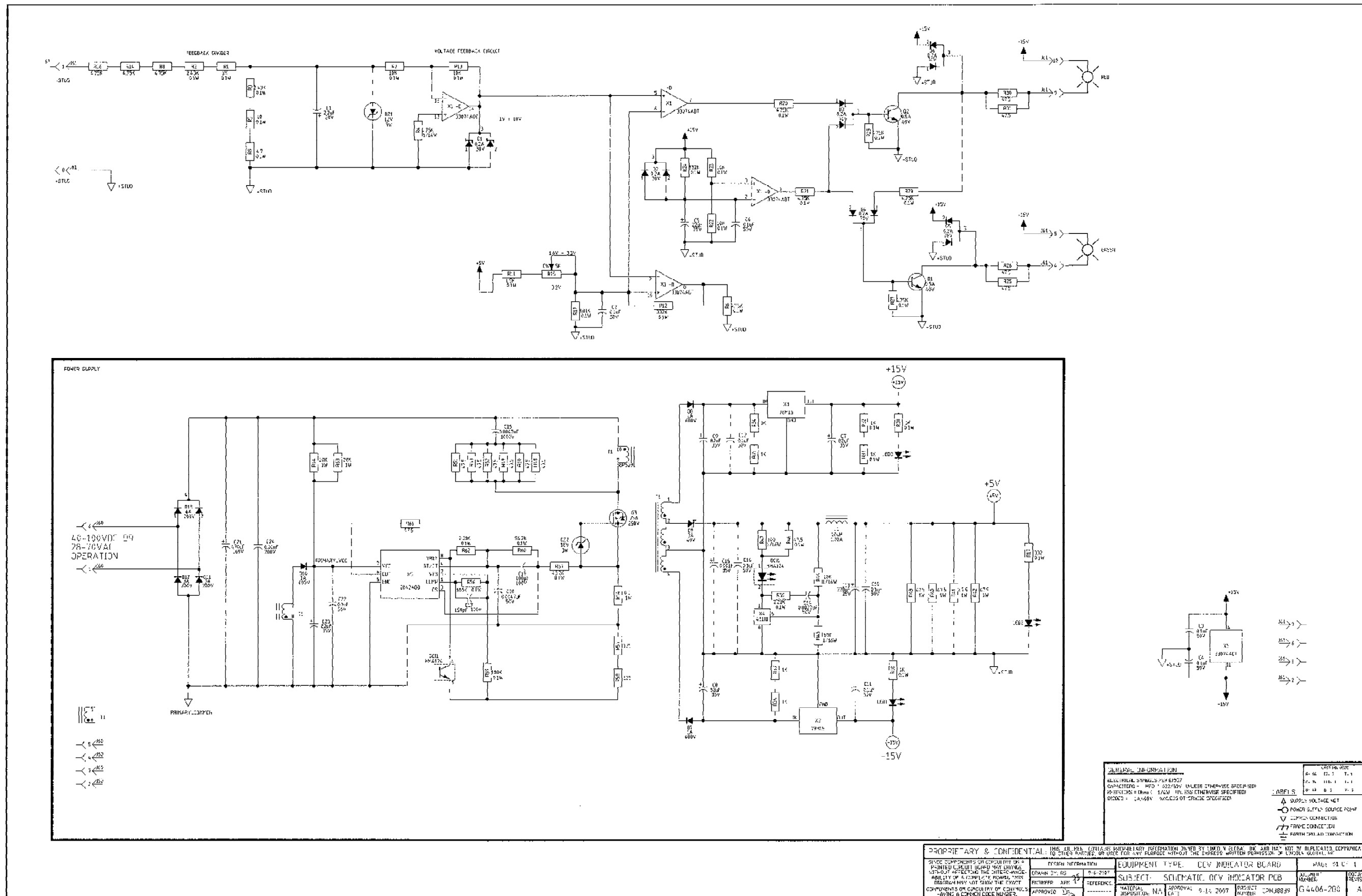

NOTE: This diagram is for reference only. It may not be accurate for all machines covered by this manual.

SCHEMATIC - BY PASS / STABILIZER PC BOARD (S22530-3D0)

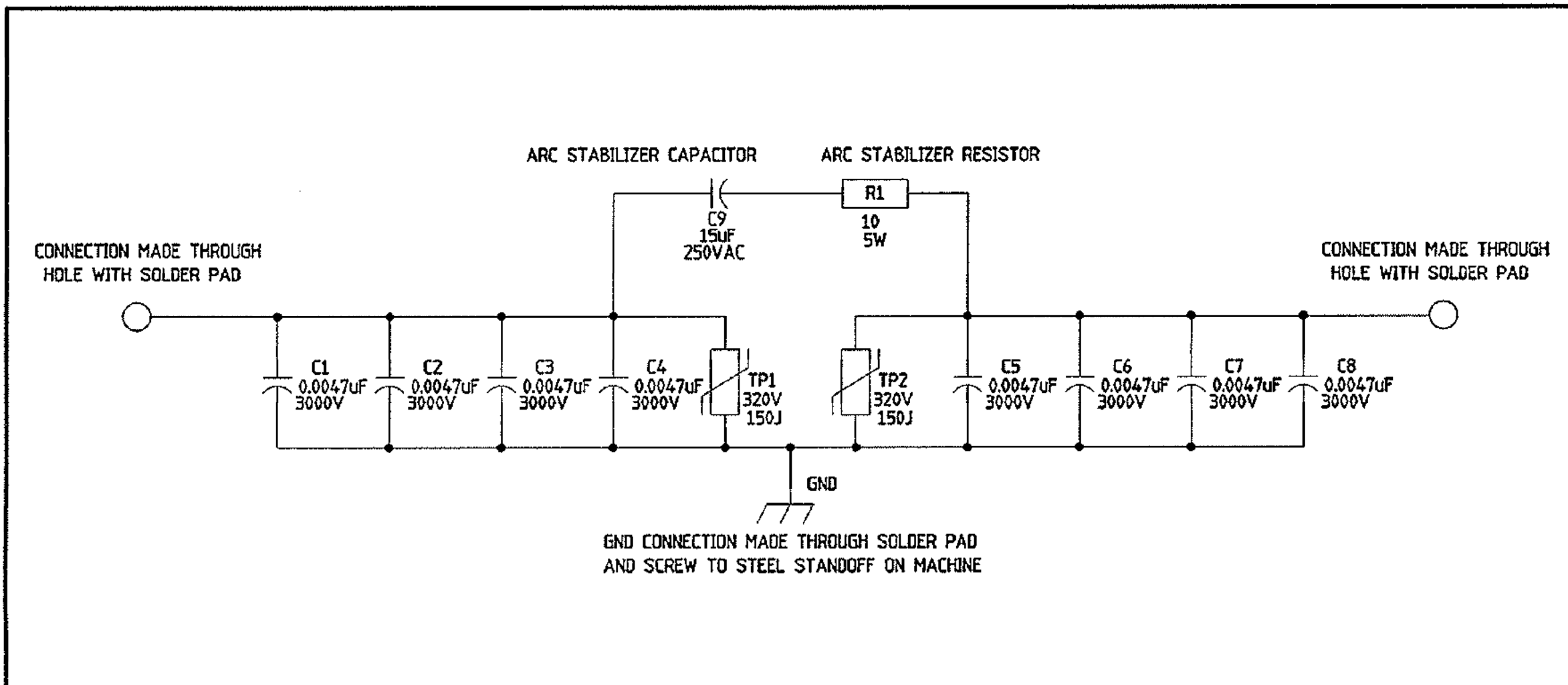

GENERAL INFORMATION

ELECTRICAL SYMBOLS PER E1537
 CAPACITORS = MFD (.022/50V UNLESS OTHERWISE SPECIFIED)
 RESISTORS = Ohms (1/4W UNLESS OTHERWISE SPECIFIED)
 DIODES = 1A,400V (UNLESS OTHERWISE SPECIFIED)

LAST NO. USED	
R- 1	TP- 2
C- 9	
D- -	

LABELS

- △ SUPPLY VOLTAGE NET
- POWER SUPPLY SOURCE POINT
- ▽ COMMON CONNECTION
- ⎓ FRAME CONNECTION
- ⊥ EARTH GROUND CONNECTION

PROPRIETARY & CONFIDENTIAL: THIS DOCUMENT CONTAINS PROPRIETARY INFORMATION OWNED BY LINCOLN GLOBAL, INC. AND MAY NOT BE DUPLICATED, COMMUNICATED TO OTHER PARTIES, OR USED FOR ANY PURPOSE WITHOUT THE EXPRESS WRITTEN PERMISSION OF LINCOLN GLOBAL, INC.

SINCE COMPONENTS OR CIRCUITRY ON A PRINTED CIRCUIT BOARD MAY CHANGE WITHOUT AFFECTING THE INTERCHANGEABILITY OF A COMPLETE BOARD, THIS DIAGRAM MAY NOT SHOW THE EXACT COMPONENTS OR CIRCUITRY OF CONTROLS HAVING A COMMON CODE NUMBER.	DESIGN INFORMATION	REFERENCE:	EQUIPMENT TYPE:	PAGE 01 OF 1	
	DRAWN BY: FM FM	S22530	SW TIG 175 & 275	DOCUMENT NUMBER:	DOCUMENT REVISION:
	ENGINEER: TN	DO NOT SCALE THIS DRAWING	SUBJECT: SCHEMATIC, BYPASS/STABILIZER PCB	S 22530-3D0	A
	APPROVED: <i>Dus</i>		MATERIAL DISPOSITION: NA	APPROVAL DATE: 8/22/2006	PROJECT NUMBER: CRM38150-A

NOTE: This diagram is for reference only. It may not be accurate for all machines covered by this manual.

Return to Section TOC | Return to Master TOC

PC BOARD ASSEMBLY - BY PASS / STABILIZER PC BOARD (L10121-3)

8-121011	ENGINEERING CONTROLLED MANUFACTURER: No	CHANGE DETAIL: REVISED P.C. BOARD BLANK INFORMATION
-----------------	--	---

P.C. BOARD BLANK INFORMATION
 BUY COMPLETE AS L10121-D (2 LAYER BOARD PER E3281 WITH LEAD FREE HASL SURFACE FINISH).
 MAKES 12 BOARDS PER PANEL.
 SEE ELECTRONIC FILE FOR ADDITIONAL INFORMATION

REFERENCES	QTY	PART NUMBER	DESCRIPTION
C1, C2, C3, C4, C5, C6, C7, C8	8	T11577-58K	CAPACITOR, CD, .0047, 3000V, 20%
C9	1	S13490-155	CAPACITOR, POLYPROPYLENE METALLIZED FILM, PPMF, 15MF, 250VAC, 10%
R1	1	T14648-25	RESISTOR, WW, 5W, 10.5%, SQ
TP1, TP2	2	T13640-18	MOV, 320VRMS, 150J, 20MM

CAPACITORS = MFD/VOLTS
INDUCTANCE = HENRYS

ITEM	REQ'D	PART NO.	IDENTIFICATION
1	1	SEE BLANK INFO.	P.C. BOARD BLANK
3	.16 OZ	E2861	SEALANT

NOTES:

- N.C. SQUEEZE TOGETHER ITEMS C1-C4, TP1 AND C5-C9, TP2 BEFORE APPLYING SEALANT.
- N.D. APPLY SEALANT AS SHOWN.
- N.F. KEEP THIS AREA FREE OF ENCAPSULATION, TOP AND BOTTOM OF BOARD.
- N.G. TIN ALL EXPOSED COPPER WITH SOLDER IN THIS AREA, BOTH SIDES OF BOARD.
- N.H. NO ICICLES OR SOLDER BLOBS ARE PERMITTED WITHIN 0.5" Ø (BOTH SIDES).

MANUFACTURED AS:

L10121-3D0

IDENTIFICATION CODE

MAKE PER E1911-ROHS
ENCAPSULATE WITH E1844,
2 COATS.
TEST PER E3553-B

SCHEMATIC REFERENCE: S22530-3D0

ALL COMPONENTS AND MATERIALS USED IN THIS ASSEMBLY ARE TO BE RoHS COMPLIANT PER E4253.

FOR PARTS ORDERS ONLY:
INCLUDE S22772PRINT

PROPRIETARY & CONFIDENTIAL: THIS DOCUMENT CONTAINS PROPRIETARY INFORMATION OWNED BY LINCOLN GLOBAL, INC. AND MAY NOT BE DUPLICATED, COMMUNICATED TO OTHER PARTIES OR USED FOR ANY PURPOSE WITHOUT THE EXPRESS WRITTEN PERMISSION OF LINCOLN GLOBAL, INC.			
MANUFACTURING TOLERANCE PER E2058 UNLESS OTHERWISE SPECIFIED TOLERANCE ON 2 PLACE DECIMALS IS ± .02 in. (± 0.5 mm) ON 3 PLACE DECIMALS IS ± .002 in. (± 0.05 mm) ON ALL ANGLES IS ± 5 OF A DEGREE MATERIAL TOLERANCE (1) TO AGREE WITH PUBLISHED STANDARDS DO NOT SCALE THIS DRAWING	CONTROL: CLEVELAND DRAWN BY: fivory ENGINEER: - APPROVED: -	SCALE: 1:1 IF PRINTED @ A2 SIZE UNITS: INCH MATERIAL DISPOSITION: UF DATE: 9-2007	EQUIPMENT TYPE: SW TIG 175 & 275 SUBJECT: BYPASS/STABILIZER P.C. BOARD ASSEMBLY PROJECT NUMBER: CRM34432 REFERENCE: L10121-1
			PAGE 1 OF 1 DOCUMENT REVISION: C

Return to Section TOC

NOTE: Lincoln Electric assumes no responsibility for liabilities resulting from board level troubleshooting. PC Board repairs will invalidate your factory warranty. **Individual Printed Circuit Board Components are not available from Lincoln Electric.** This information is provided for reference only. Lincoln Electric discourages board level troubleshooting and repair since it may compromise the quality of the design and may result in danger to the Machine Operator or Technician. Improper PC board repairs could result in damage to the machine.



WIRING DIAGRAM - COMPLETE MACHINE - (G5481)

Return to Section TOC
Return to Master TOC

Return to Section TOC
Return to Master TOC

Return to Section TOC
Return to Master TOC

Return to Section TOC
Return to Master TOC

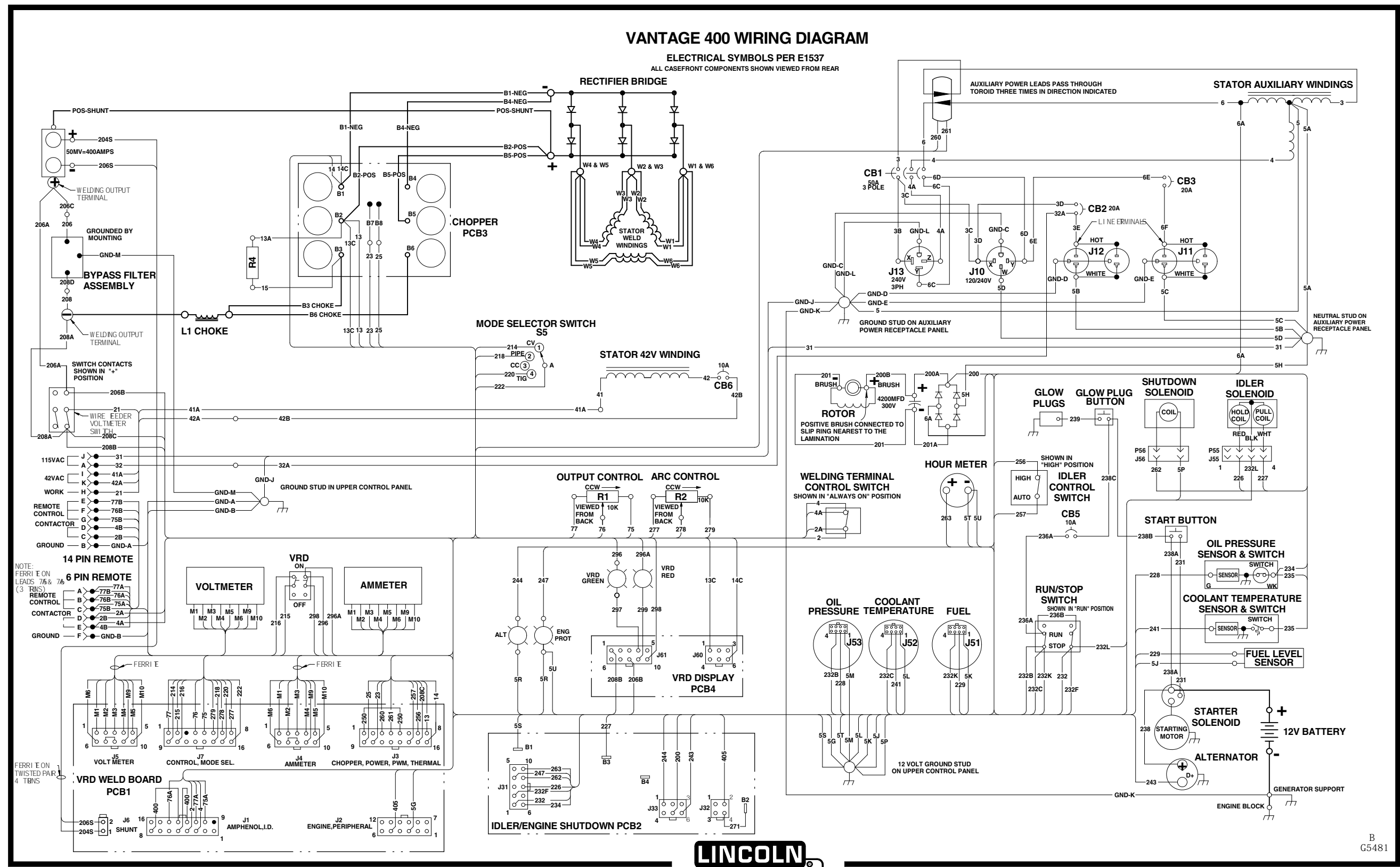

CLEVELAND, OHIO, U.S.A.

B
G5481

NOTE: This diagram is for reference only. It may not be accurate for all machines covered by this manual. The wiring diagram specific to your code is pasted inside one of the enclosure panels of your machine.

Wiring Diagram Complete Machine - G7138 codes 11785, 11920

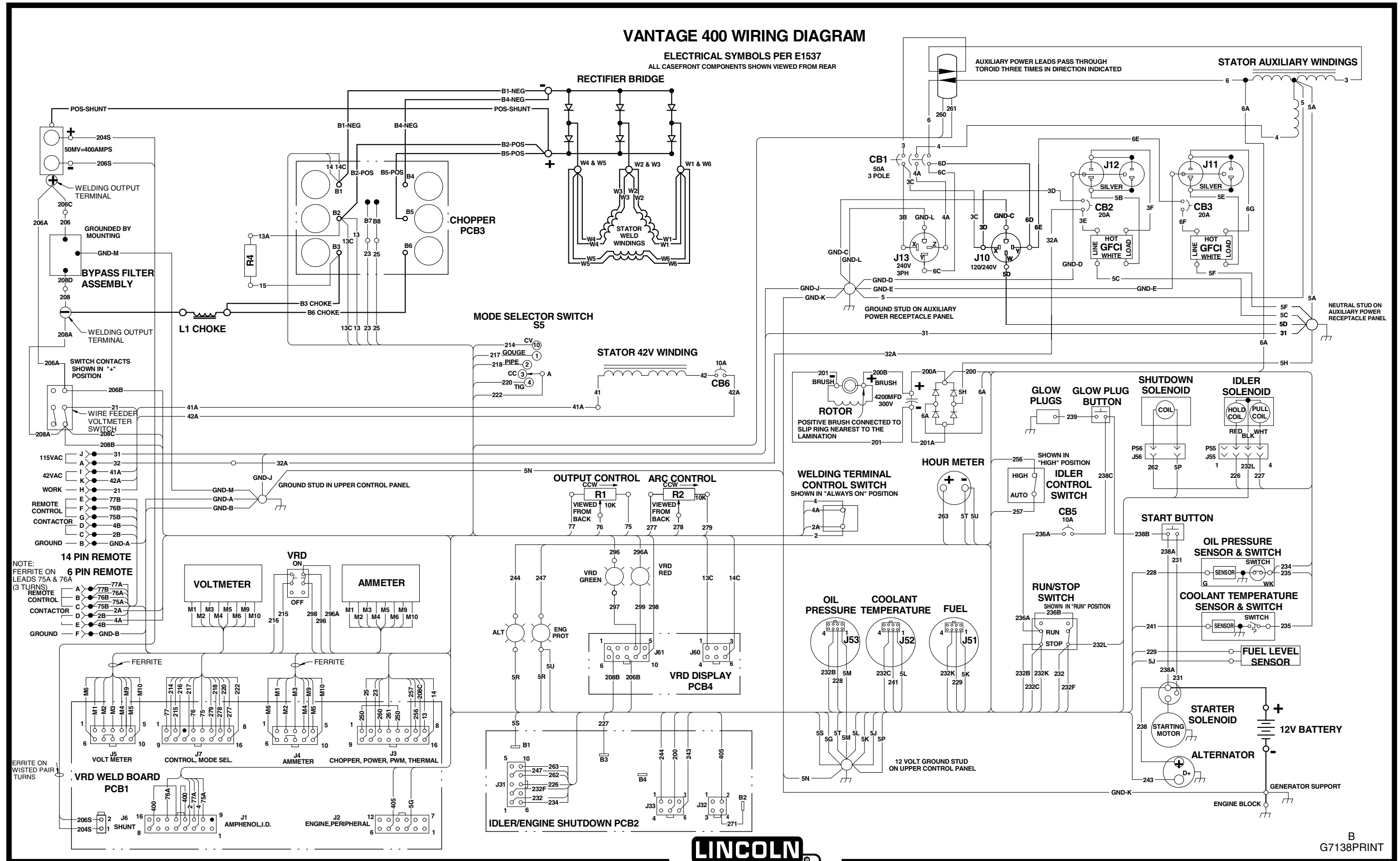

B
G7138PRINT

NOTE: Lincoln Electric assumes no responsibility for liabilities resulting from board level troubleshooting. PC Board repairs will invalidate your factory warranty. **Individual Printed Circuit Board Components are not available from Lincoln Electric.** This information is provided for reference only. Lincoln Electric discourages board level troubleshooting and repair since it may compromise the quality of the design and may result in danger to the Machine Operator or Technician. Improper PC board repairs could result in damage to the machine.

Schematic Complete Machine - G6379 Codes 11785, 11920 Page 1

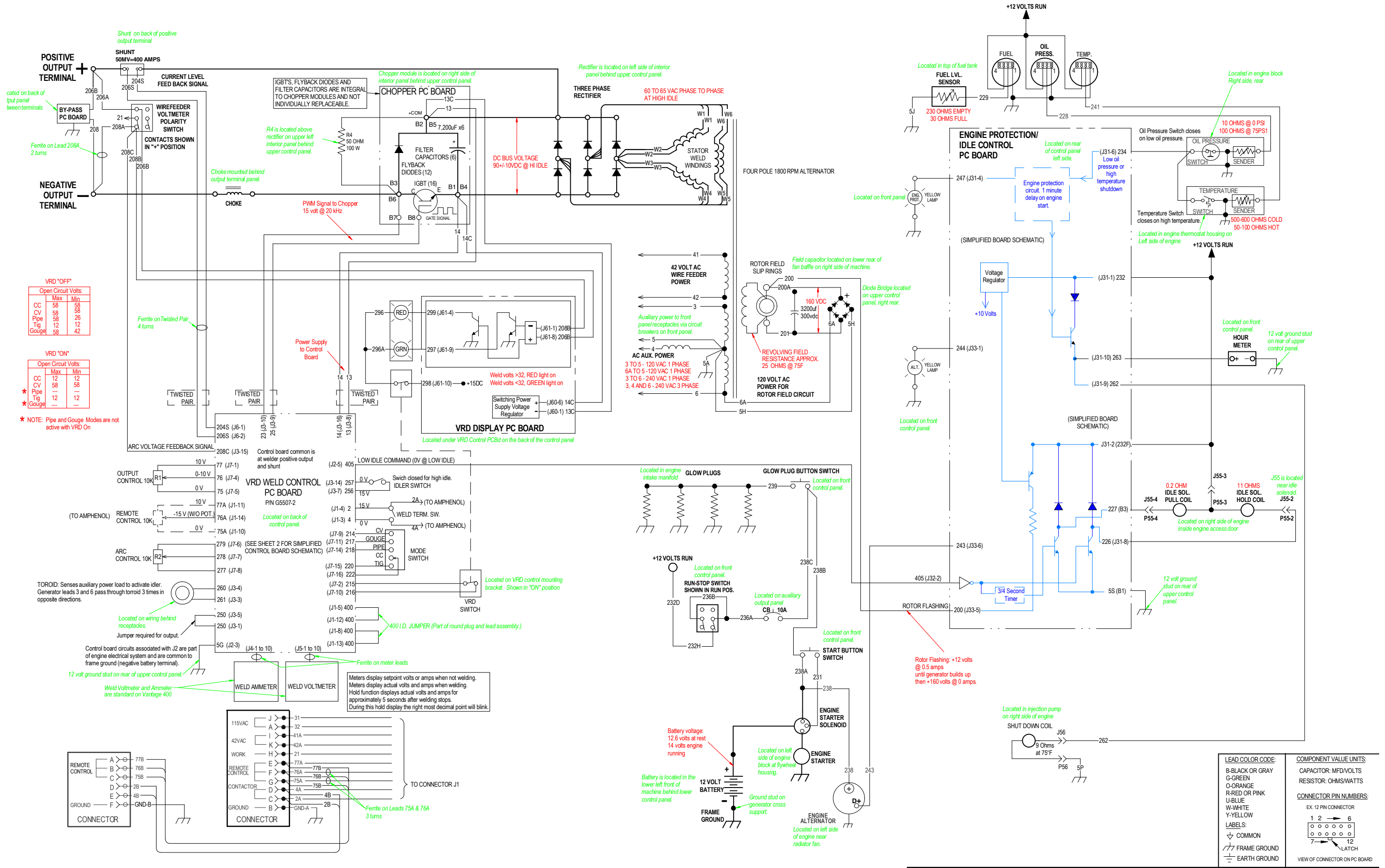

NOTE: Lincoln Electric assumes no responsibility for liabilities resulting from board level troubleshooting. PC Board repairs will invalidate your factory warranty. **Individual Printed Circuit Board Components are not available from Lincoln Electric.** This information is provided for reference only. Lincoln Electric discourages board level troubleshooting and repair since it may compromise the quality of the design and may result in danger to the Machine Operator or Technician. Improper PC board repairs could result in damage to the machine.

Schematic Complete Machine - G6379 Codes 11785, 11920 Page 2

SIMPLIFIED CONTROL BOARD SCHEMATIC

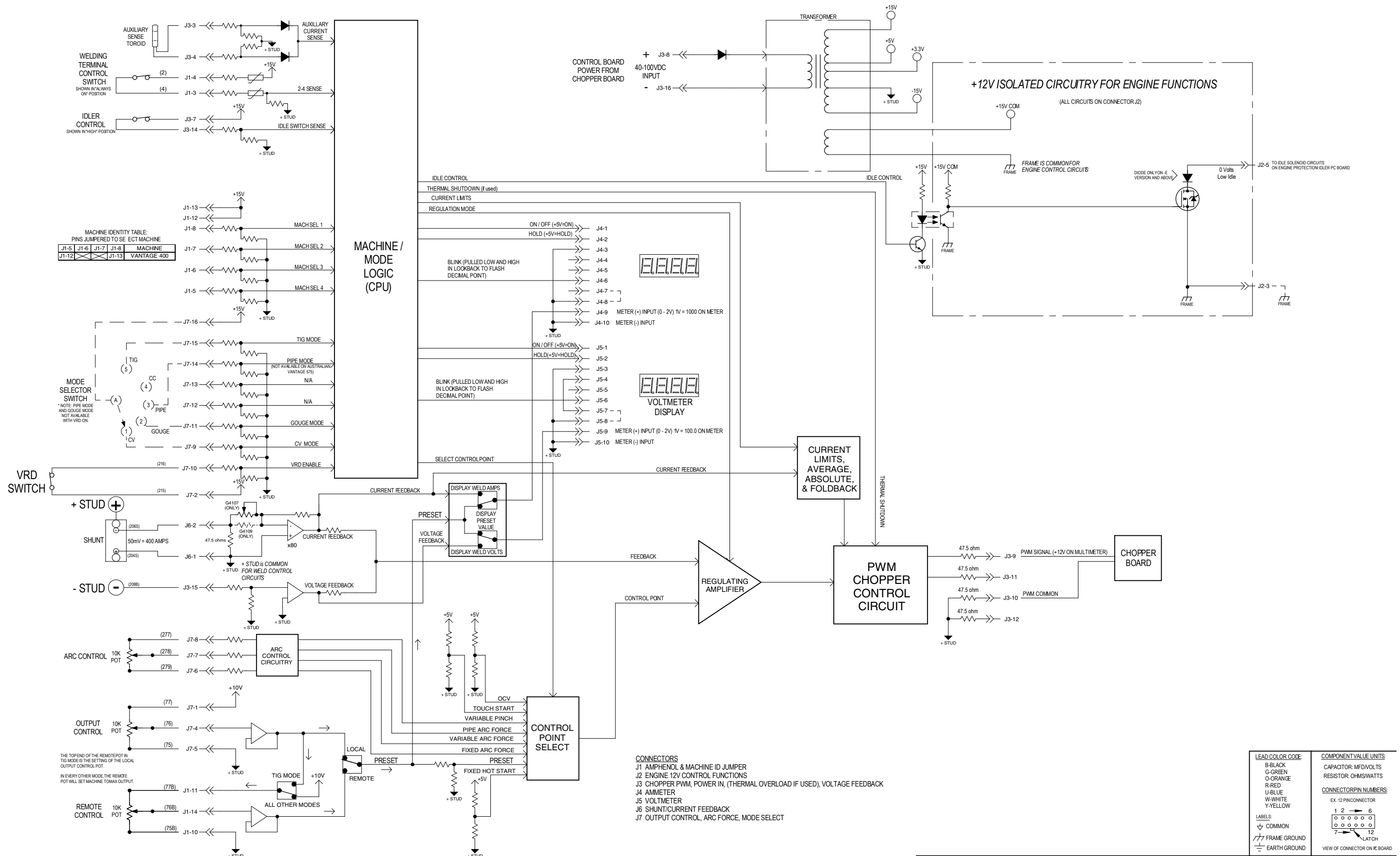

NOTE: Lincoln Electric assumes no responsibility for liabilities resulting from board level troubleshooting. PC Board repairs will invalidate your factory warranty. **Individual Printed Circuit Board Components are not available from Lincoln Electric.** This information is provided for reference only. Lincoln Electric discourages board level troubleshooting and repair since it may compromise the quality of the design and may result in danger to the Machine Operator or Technician. Improper PC board repairs could result in damage to the machine.