

HEAT DETECTOR SET

GUARDIAN™ Fire Safety Solutions for Fume Control Systems

HEAT POINT DETECTOR

A set of temperature detectors can be installed in the fume control system filter housing. When measuring excessive heat, detectors deliver a signal to the Guardian Control™ fire detection panel to activate the fire suppression system.



APPLICATIONS:

The heat detector set is part of Lincoln Electric's GUARDIAN™ fire safety solutions for fume control systems and is recommended for applications with an increased fire risk, such as:

- Robotic welding of oily stamped products
- Robotic and automatic welding of oily products
- Manual welding of oily products
- Cutting tables
- Schools/Other areas with risk of cigarette butts

SPECIFICATIONS:

• Physical Dimensions and Properties:

- Housing Dimensions (H x W x D):
3.2 x 3.0 x 2.2 in (80 x 75 x 56 mm)
- Housing Material: Aluminum
- Heat Detector Dimensions
(w/ threaded rod): L = 4.5 in (115 mm);
D = 0.59 in (15 mm)
- Heat Detector Material:
Tube: High alloy steel
Screw Thread: Brass

• Technical Data:

- Electrical Rating:
5.0 Amps 126 VAC; 0.5 Amps 125 VDC
2.0 Amps 24 VDC; 1.0 Amps 48 VDC
- Temperature Setting; Tolerance:
190°F (88°C); +7/-8°F (+14/-13°C)
- Acting Type: NO (normally open)
- Protection Class: IP 65

• What's Included:

- 2 - Heat detector
- 2 - Junction box (2)
- 2 - Cable gland M25, nickel plated brass
- 2 - Nut cable gland M25, nickel plated brass
- 4 - Cable gland M16, black nylon

APPROVALS/CERTIFICATES



LINCOLN[®]
ELECTRIC



HEAT DETECTOR SET

GUARDIAN™ Fire Safety Solutions for Fume Control Systems

EXPLODED VIEW OF HEAT DETECTOR

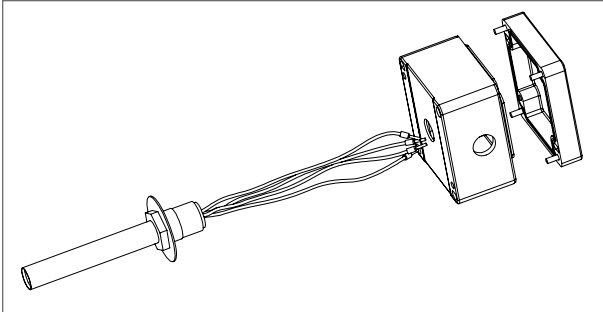

MOUNTING POSITIONS

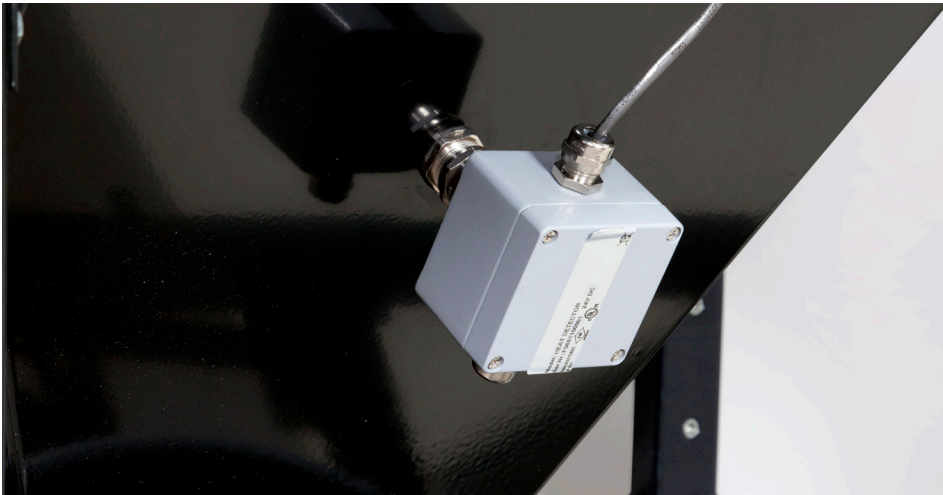

- 1st Heat Detector: On top of filter housing (not shown)
- 2nd Heat Detector: In hopper just above dustbin

ORDER INFORMATION

Product Name	Product Number	Number/package
Heat Detector	AD1387-25	Set of 2

The operation of welding fume control equipment is affected by various factors including proper use and positioning of the equipment, maintenance of the equipment and the specific welding procedure and application involved. Worker exposure level should be checked upon installation and periodically thereafter to be certain it is within applicable OSHA PEL and ACGIH TLV limits.

Lincoln Electric Product Claim - Weld fume control products manufactured by The Lincoln Electric Company are designed to be utilized as an engineering safety control to aid in achieving adequate ventilation while conducting welding or it's allied processes. The operation of welding fume control equipment is affected by various factors including proper use and positioning of the equipment, and the specific welding procedure and application involved. When the equipment is used as designed - and when properly installed, operated and maintained - it can be a valuable and effective tool to help employers maintain adequate ventilation in the workplace. Lincoln Electric defines adequate ventilation as that which is required to maintain occupational exposure levels below the applicable exposure limits when sound work practices are utilized. Worker exposure level should be checked upon installation and periodically thereafter to be certain it is within applicable OSHA PEL and ACGIH TLV limits.

CUSTOMER ASSISTANCE POLICY

The business of The Lincoln Electric Company is manufacturing and selling high quality welding equipment, consumables, and cutting equipment. Our challenge is to meet the needs of our customers and to exceed their expectations. On occasion, purchasers may ask Lincoln Electric for information or advice about their use of our products. Our employees respond to inquiries to the best of their ability based on information provided to them by the customers and the knowledge they may have concerning the application. Our employees, however, are not in a position to verify the information provided or to evaluate the engineering requirements for the particular weldment. Accordingly, Lincoln Electric does not warrant or guarantee or assume any liability with respect to such information or advice. Moreover, the provision of such information or advice does not create, expand, or alter any warranty on our products. Any express or implied warranty that might arise from the information or advice, including any implied warranty of merchantability or any warranty of fitness for any customers' particular purpose is specifically disclaimed.

Lincoln Electric is a responsive manufacturer, but the selection and use of specific products sold by Lincoln Electric is solely within the control of, and remains the sole responsibility of the customer. Many variables beyond the control of Lincoln Electric affect the results obtained in applying these types of fabrication methods and service requirements.

Subject to Change - This information is accurate to the best of our knowledge at the time of printing. Please refer to www.lincolnelectric.com for any updated information.

E13.102 (07/12) © Lincoln Global, Inc. All Rights Reserved. Printed in the U.S.A.

WORLD-CLASS WELD FUME CONTROL EXPERTISE

Our technical sales team is trained and knowledgeable about the methodology of substitution, isolation, and ventilation. As a key partner, with a wealth of experience and knowledge of welding, welding fume and welding fume removal, we can assist you to identify the right weld fume control solution for your application. Lincoln Electric has a global network of facilities and people to provide quick response and personalized attention, no matter where your welding operations are located.

SUPPORT & TRAINING PROGRAMS

We offer support materials, training tools, free seminars and courses to enhance your welding and cutting safety program.

Our service and support programs are designed to meet your needs. For on-going preventive maintenance and support, our team can train your staff, conduct evaluations or audits and deliver the services you need to stay productive and effective.

VALUABLE CUSTOM SOLUTIONS

The Lincoln Electric weld fume control team understands and recognizes that each welding application is unique with its own set of variables; one equipment and consumable solution does not fit every application. Our team will engineer a system to efficiently and effectively remove welding fume and particulate from your metalworking operations.

Contact us today!

Automation Service Hotline

1-888-935-3878

Automation After-Hours Technical Support

1-888-532-8001



The Lincoln Electric Company

Automation Division

22801 St. Clair Avenue
Cleveland, OH 44117-1199 U.S.A.

1-216-481-8100

Email: WeldFumeControl@lincolnelectric.com

www.lincolnweldfumecontrol.com

www.lincolnelectric.com/safety