

SA 250 WIRING DIAGRAM M20016 REV:A

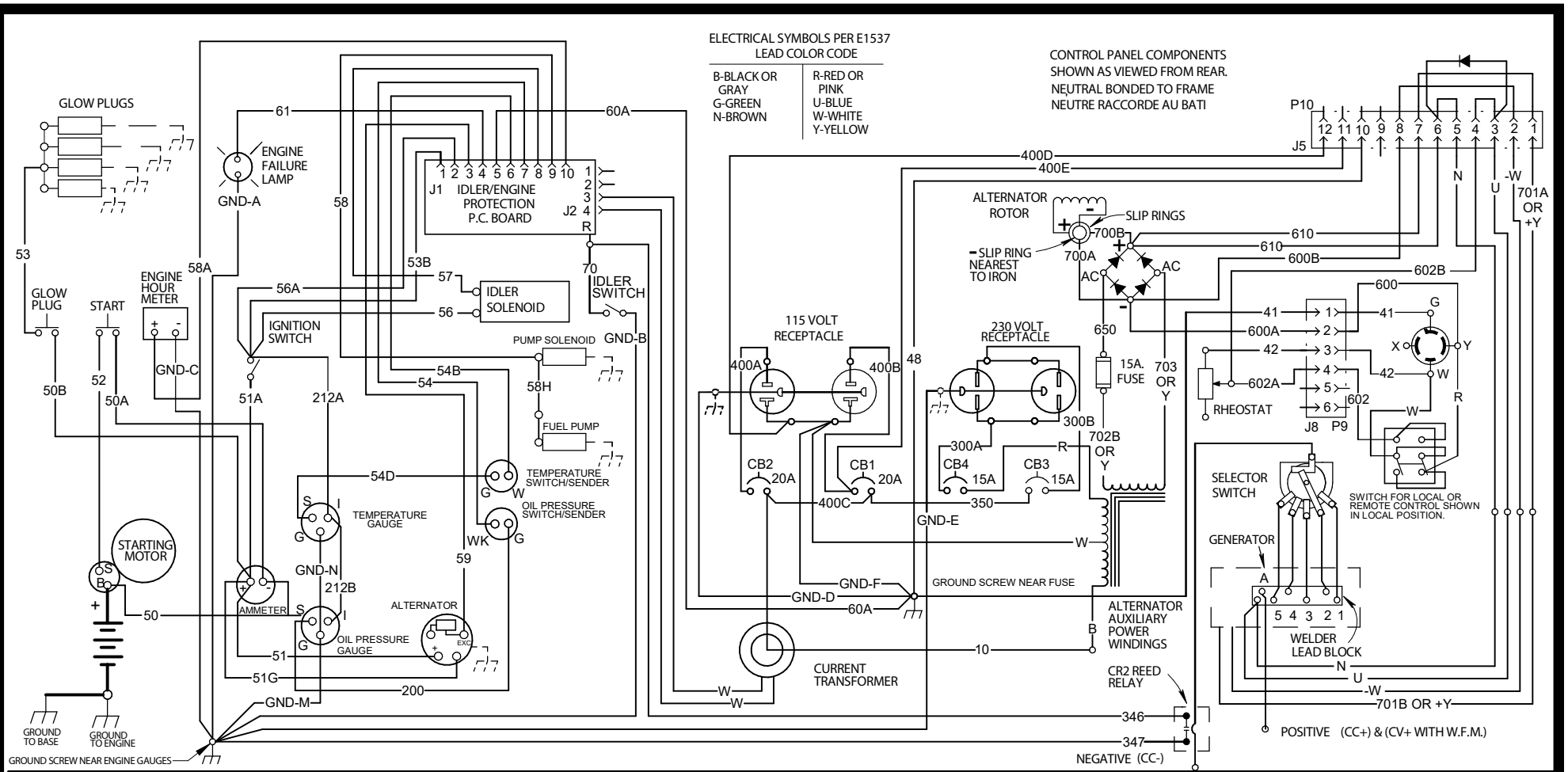

K924-5 REMOTE CONTROL (OPTIONAL)

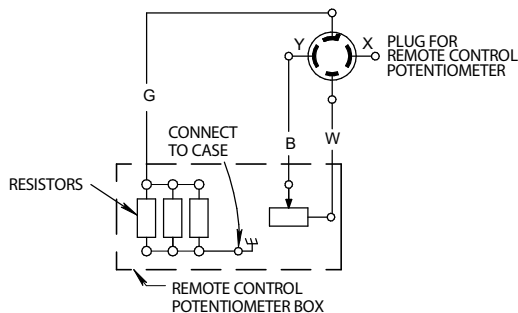

WIRE FEED MODULE (OPTIONAL)

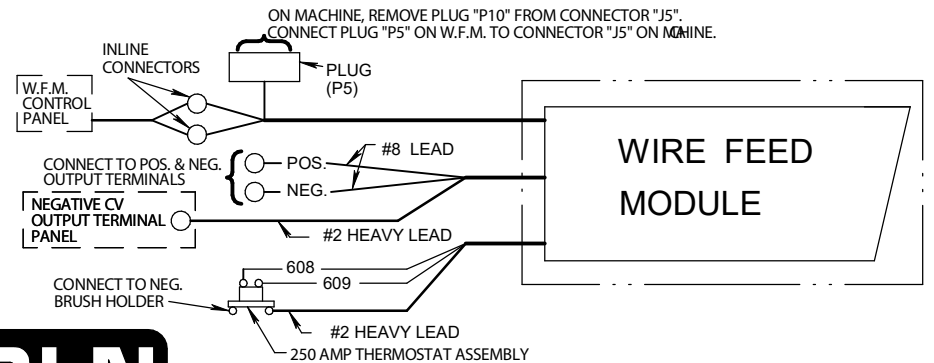

*** MACHINE MUST NOT BE RUNNING WHEN MAKING THESE CONNECTIONS.**

LINCOLN ELECTRIC

CLEVELAND, OHIO U.S.A.