

**OWNER'S OPERATING MANUAL
SERVICE PARTS SHEET**

M12184, 83-318, MB135

135 AMP MIG WELDER - SERIES A

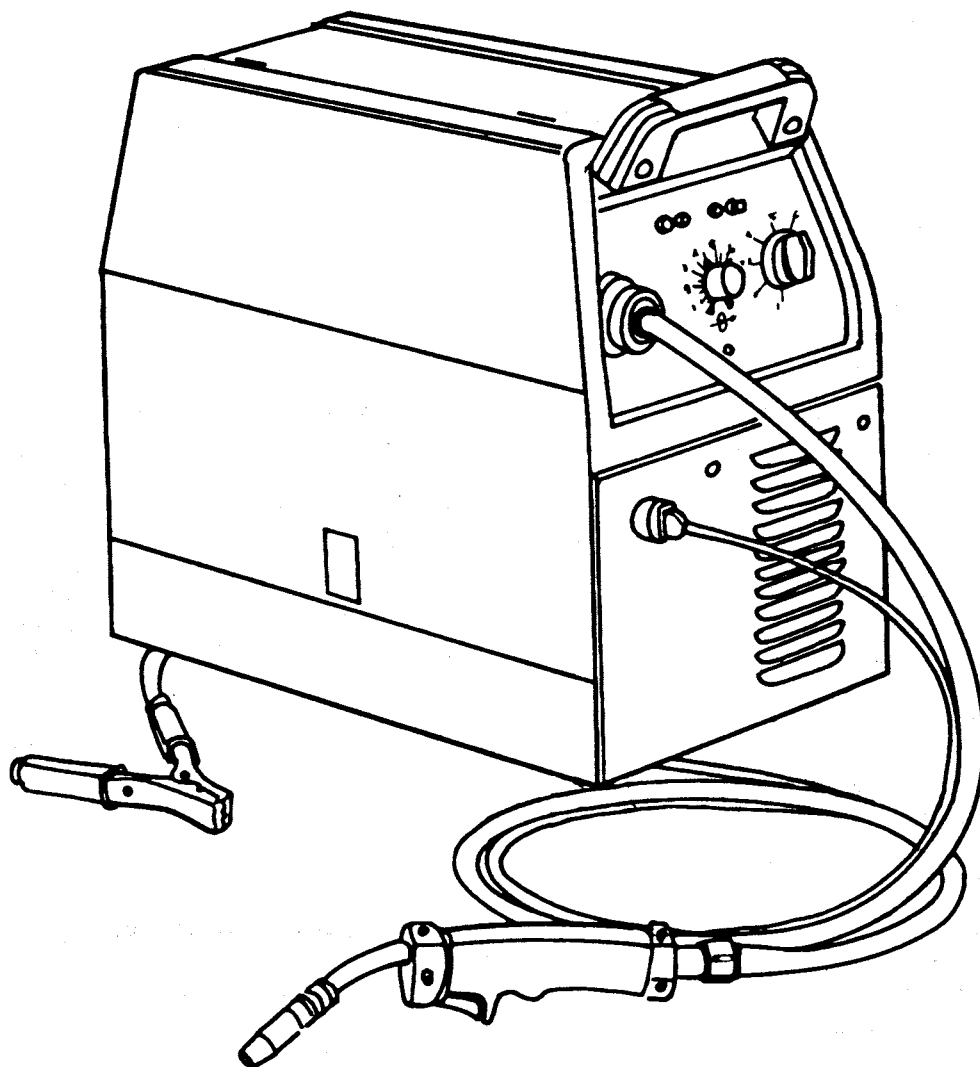

One Lincoln Way
St. Louis, Missouri 63120-1578
Customer Service (314) 679-4300

Copyright 1996
Printed in U.S.A.

Mig Section

INSTRUCTION MANUAL FOR WIRE WELDING MACHINES

IMPORTANT:

READ THIS MANUAL CAREFULLY BEFORE INSTALLING, USING, OR SERVICING THE WELDING MACHINE, PAYING SPECIAL ATTENTION TO SAFETY RULES. CONTACT YOUR DISTRIBUTOR IF YOU DO NOT FULLY UNDERSTAND THESE INSTRUCTIONS.

1 INSTALLATION

This machine must be used for welding only. It must not be used to defrost pipes.

It is also essential to pay special attention to the chapter on SAFETY PRECAUTIONS.

The symbols next to certain paragraphs indicate points requiring extra attention, practical advice or simple information.

This manual must be stored carefully in a place familiar to everyone involved in using the machine. It must be consulted whenever doubts arise and be kept for the entire lifespan of the machine; it will also be used for ordering replacement parts.

1.1 PLACEMENT

Unpack the machine and place it in an adequately ventilated area, dust-free if possible, taking care not to block the air intake and outlet from the cooling slots.

CAUTION: REDUCED AIR CIRCULATION causes overheating and could damage internal parts.

Keep at least 500 mm of free space around the machine. Never place any filtering device over the air intake points of this welding machine.

The warranty shall become void if any type of filtering device is used.

Mount the parts supplied with the machine as shown in the figure 1.

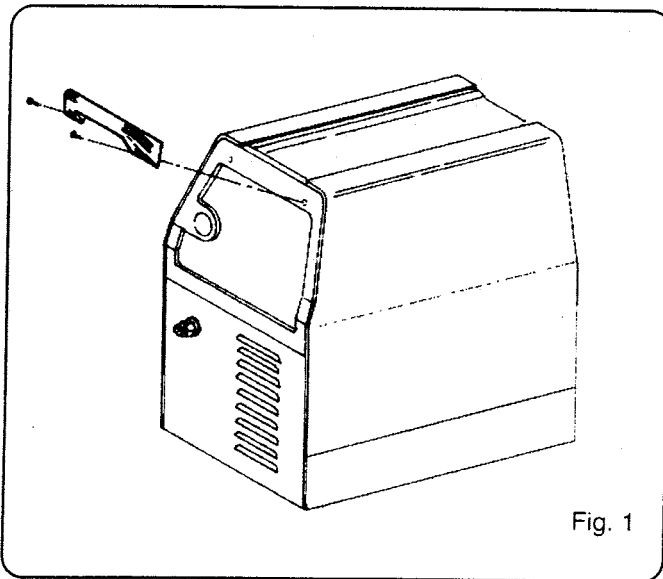

Fig. 1

2 DESCRIPTION OF THE MACHINE

A) Switch

- B) **Setting knob**
This knob serves to adjust the welding wire speed.
- C) **Earth cable**
- D) **Yellow LED**
Lights only when the thermostat is tripped and interrupts the machine operation.
- E) **Green LED**
Indicates that the machine is turned on.
- F) **Welding torch**
- G) **Handle**
Must not be used to lift the machine.

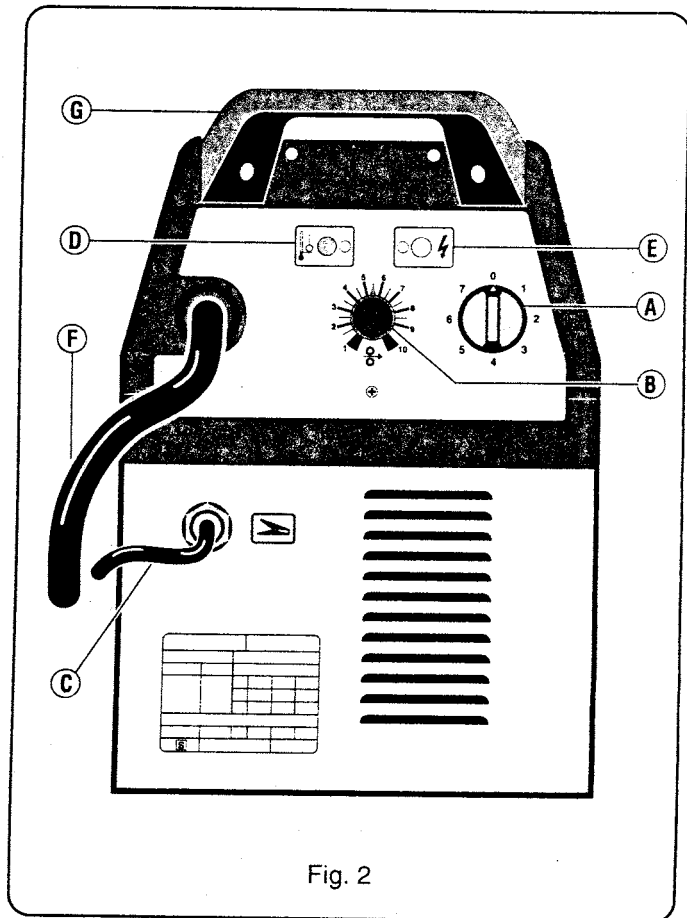

Fig. 2

3 GENERAL DESCRIPTIONS

3.1 SPECIFICATIONS

This welding machine allows welding of soft steel, stainless steel and aluminium.

3.2 EXPLANATION OF TECHNICAL SPECIFICATIONS



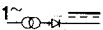

EN60974.1 The welding machine is built according to these international standards.

N° Serial number, which must always be indicated in any inquiry regarding the welding machine.

 Single-phase rectifier - transformer.

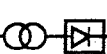
 External machine characteristic.

- U₀** Secondary no-load voltage (peak value)
X The duty cycle expresses the percentage of 10 minutes during which the welding machine can run at a certain current without overheating. Example: X = 60% at I₂ = 100 A
 This means that the machine can weld with a current I₂ = 100A for 6 out of 10 minutes, thus 60%.
- I₂** Welding current
U₂ Secondary voltage with welding current I₂
U₁ Rated power voltage.
1~ 50/60 Hz Single-phase 50-or 60-Hz power supply.
I₁ Current absorbed at the corresponding welding current I₂
IP21 Degree of housing protection.
 Grade one as the second digit means that this device is not suitable for use outdoors in the rain.
S Suitable for use in increased hazard areas.

1 ~  =		N ^o			
I ₂ max. ...A		EN 60974.1			
	U ₀ V ÷ V	X	%	%	%
		I ₂	A	A	A
		U ₂	V	V	V
					
1~50/60Hz	U ₁ V	I ₁	A	A	A
S	MADE IN ITALY		IP 21		

NOTE: The welding machine has also been designed for use in environments with grade 3 pollution (see IEC 664)

3.3 DESCRIPTION OF PROTECTION

This device is protected by a normally closed thermostat on the power transformer.

When the thermostat is tripped the machine stops welding, while the motor-driven fan continues to run and the yellow LED lights.

After it has been tripped, wait a few minutes to allow the generator to cool down.

4 INSTALLATION

The machine must be installed by skilled personnel. All connections must be made in compliance with current regulations and in full respect of safety laws (see standards CEI 26-10 and CENELEC HD 427).

Make sure that the wire diameter corresponds to the one indicated on the roller, and mount the wire reel. Make sure that the welding wire passes through the groove in the small roller 7.

Before connecting the power cable 23, make sure that the power voltage corresponds to that of the welding machine,

then: a) for permanent connection to the power mains without a plug, you must insert a main switch having a suitable capacity in compliance with the rated specifications.

b) for a plug-socket connection, use a plug having a suitable capacity in compliance with the rated specifications. In this case the plug must be used to completely disconnect the machine from the mains, after setting the switch 47 to "O" (off).

The yellow-green wire must be connected to the earth terminal. Connect the earth clamp 37 to the part to be welded.

The welding circuit must not be deliberately placed in direct or indirect contact with the protection wire except in the workpiece.

If the workpiece is deliberately grounded using the protection wire, the connection must be as direct as possible, using a wire at least as large as the welding current return wire, and connected to the workpiece at the same point as the return wire, using the return wire clamp or a second grounding clamp placed next to it.

All precautions must be taken to avoid stray welding currents. Turn the machine on using the switch 47.

Remove the tapered gas tip 44 by turning it clockwise. Unscrew the contact tip 43.

Do not press the torch trigger until you have read the instructions carefully.

It is important to make sure the machine is turned off whenever changing the wire reel and wire roller, to prevent the wire feed motor from starting accidentally.

Press the torch trigger 39 and release it only when the welding wire comes out.

welding wire can cause puncture wounds.

Never aim the torch at parts of the body, other people or metals when loading the welding wire.

Screw the contact tip 43 back on, making sure that the hole diameter corresponds to the wire used.

Slide the tapered gas welding tip 44 on, always turning clockwise.

4.1 CONNECTING THE GAS HOSE

- The gas cylinder must be equipped with a pressure reducer and flow meter.

- If the cylinder is placed on the cylinder holder of the machine, it must be held in place by the chain provided and be of an appropriate size to avoid jeopardizing the stability of the machine.

- Connect the gas hose leaving the back of the machine to the pressure reducer only after the cylinder is in place.

- Open the gas cylinder and set the flow meter to approximately 8-10 lt./min.

CAUTION: Make sure the gas used is compatible with the material to be welded.

4.2 GENERAL NOTES

Before using this welding machine, carefully read the regulations CEI 26/9 or CENELEC HD 407 and CEI 26/11 or CENELEC HD 433. Also make sure that the insulation on cables, torch and earth cable is intact.

5 WELDING

5.1 WELDING MILD STEEL

5.1.1 With gas protection.

Either 75% ARGON + 25% CO₂ or 100% CO₂ may be used for welding mild steel.

Connect the cables as shown in the figure 3.

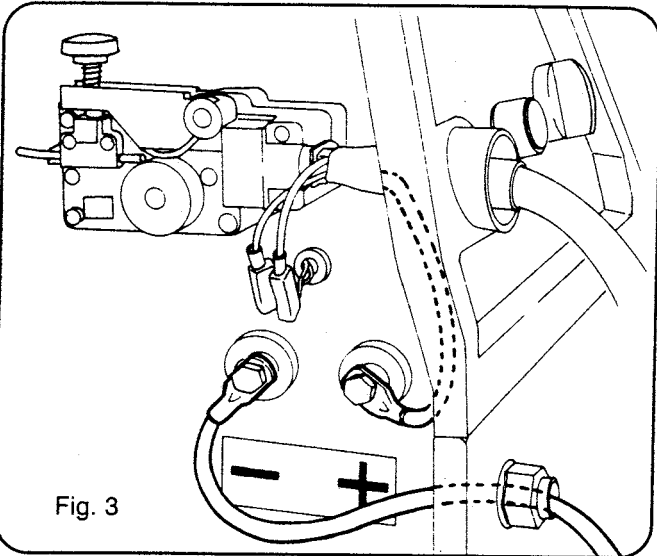

Fig. 3

Select the welding current by means of the rotary switch 47. Move the torch near the welding point and press the trigger 39. Adjust the potentiometer knob 2 until the welding is done with a constant, continuous noise.

If the speed is too fast, the wire tends to stick to the piece and cause the torch to skip; if the speed is too low, the wire melts in spaced drops or the arc does not remain lit.

When you have finished welding, turn off the machine and close the gas cylinder.

For the correct welding angle see figure 5.

5.1.2 Without gas protection.

Connect the cables as shown in the figure 4.

Use only diam. 0.9 flux cored wire that complies with the standard AWS AS.20 E71 T11 or E71 TGS, suitable for use

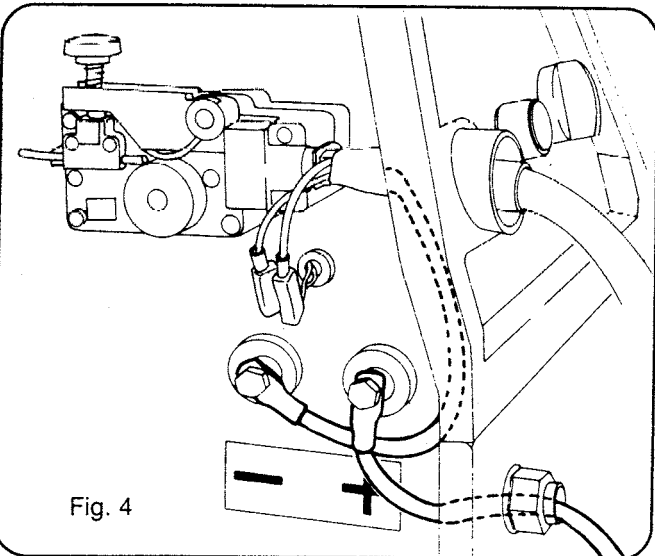

Fig. 4

without gaseous protection.

Connect the earth cable clamp to the workpiece.

After connecting the cables, follow the instructions given in paragraph 5.1.1.

NOTE: For compact, well-protected welds always work from left to right and from top to bottom.

Remove all waste after each welding operation.

For the correct welding angle see figure 5.

5.2 WELDING ALUMINIUM

The welding machine must be prepared as for welding mild steel with gas protection, but with the following differences:

- 100% ARGON as the protection gas for welding.
- A wire having a composition suited to the base material to be welded.

For welding ALLUMAN: 3+5% silicon wire

- For welding ANTICORODAL: 3+5% silicon wire

- For welding PERALUMAN: 5% magnesium wire

- For welding ERGAL: 5% magnesium wire

Use grinding wheels and brushes specifically designed for aluminium, and never use them on other materials.

REMEMBER that cleanliness is quality!

The wire reels must be stored in nylon bags with dehumidifying packets.

For the correct welding angle see figure 5.

5.3 WELDING STAINLESS STEEL

The welding machine must be prepared as for welding mild steel with gas protection, but with the following differences:

- Reel of stainless steel wire compatible with the composition of the material to be welded.

- Cylinder containing 98% ARGON + 2% O₂ (recommended composition)

The recommended torch angle and welding direction are shown in figure 5.

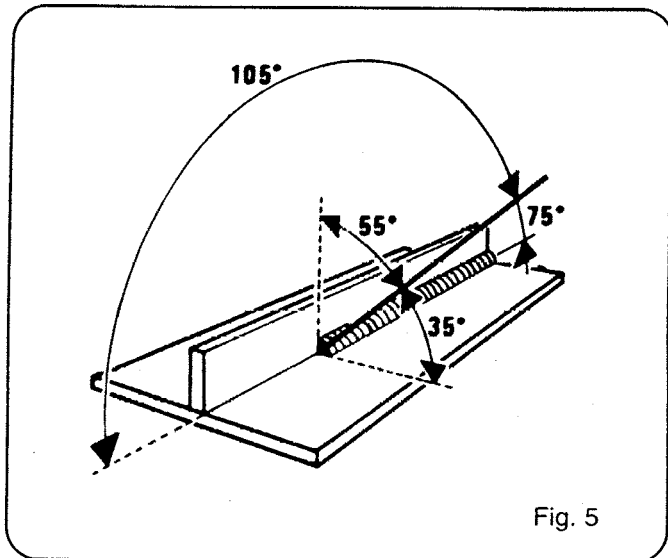

Fig. 5

6 MAINTENANCE AND CHECKS

6.1 GENERAL NOTES

- Turn off the welding machine and unplug the power cord

from the socket before each checking and maintenance operation.

- Moving parts can cause serious lesions
- Keep away from moving parts.
- INCANDESCENT SURFACES can cause serious burns.
- Let the unit cool before servicing.
- Periodically remove any dust or foreign matter that may have deposited on the transformer or diodes; to do so, use a jet of clean, dry air.
- When replacing the wire roller, make sure the groove is aligned with the wire and corresponds to the diameter of the wire used.
- Always keep the interior of the gas nozzle clean to avoid metal bridges created by welding dross between the gas nozzle and the contact tip. Make sure the outlet hole of the contact tip has not expanded excessively; if so, replace.
- Strictly avoid striking the torch or allowing it to suffer violent impact.

6.2 REPAIRING THE WELDING MACHINE

Experience has shown that many accidents are caused by repairs performed incorrectly. That is why it is just as important to check a repaired welding machine carefully and completely as it is for a new welding machine. In addition, this protects the manufacturer from being held liable for defects when the true fault lies elsewhere.

6.2.1 Instructions for performing repairs

- After rewinding the transformer or inductance, the welding machine must pass the applied voltage tests as indicated in table 2 of paragraph 6.1.3 of the standard EN 60974.1 (CEI 26.13). Compliance must be verified as specified in 6.1.3.
- If no rewinding has been done, a welding machine that has been cleaned and/or revised must pass an applied voltage test with test voltage values equal to 50% of the values given in table 2 of paragraph 6.1.3. Compliance must be verified as specified in 6.1.3.
- After rewinding and/or replacing parts, the no-load voltage must not exceed the values given in paragraph 10.1 of EN 60974.1.
- If the repairs have not been performed by the manufacturer, repaired welding machines in which some components have been replaced or altered must be marked in such a way that the person who performed the repairs is clearly identifiable.
- After making repairs, take care to re-order the wiring so that there is certain insulation between the primary side and the secondary side of the machine. Prevent the wires from coming into contact with moving parts or parts that heat up during operation. Replace all clamps as on the original machine to prevent a connection from occurring between the primary and secondary side if a conductor accidentally breaks or disconnects.

6.3 TROUBLESHOOTING GUIDE

TROUBLE	PROBABLE CAUSE	REMEDY
The welding machine supplies limited current	Line fuse blown	Replace line fuse
	Burnt out diode or diodes	Replace
	Burnt out electronic board	Replace
	Loosened torch or earth connections or any other electrical power connections	Tighten all connections
Welding with a lot of metal spatter	Voltage adjustment switch has a loose contact	Replace the switch
	Improper adjustment of welding parameters	Select the correct parameters through the welding-voltage switch and the wire-speed adjustment potentiometer
	Insufficient grounding	Check grounding connections
The wire jams or entangles between the drive rolls and the torch infeed wire guide	Contact tip with wrong diameter	Replace
	Misalignment of the drive roll groove	Realign
	Obstructed or clogged liner	Remove and clean
No wire feed or irregular wire feed	Drive roll with too large a groove	Replace the drive roll
	Obstructed or clogged liner	Remove and clean
	Wire holding roller not completely tightened	Tighten all the way
	Clogged contact tip	Replace
Porosity in the welding seam	Insufficient shielding gas	Increase gas delivery
	Excess oxidation of the edges to be welded	Thoroughly clean the edges with a metal brush
	Gas nozzle partially or completely clogged by spatter	Remove and clean or replace being careful not to clog the gas outlets

7 SAFETY PRECAUTIONS

7.1 Fire



- Avoid causing fire because of sparks, slag, hot metal or pieces.
- Make sure that suitable fire-fighting equipment is available close to welding area.
- Remove all flammable and combustible material from the welding area and its surrounding (32 ft minimum).
- Do not weld containers of combustible or flammable material, even when empty. These must be carefully cleaned before being welded.
- Allow the welded material to cool down before touching it or putting it in contact with combustible or flammable material.
- Do not weld parts with hollow spaces, containing flammables.
- Do not work under conditions with high concentrations of combustible vapours, gases, or flammable dust.
- Always check the work area half an hour after welding so as to make sure that no fire has started.
- Do not keep any combustible material such as lighters or matches in your pockets.

7.2 Burns

- Wear fire-proof clothing all over your body in order to protect your skin against burns caused by ultraviolet radiation given off by the arc, and from weld metal sparks and slag.

- Wear protective clothing-gauntlet gloves designed for use in welding, hat and high safety-toe shoes. Button shirt collar and pocket flaps, and wear cuff-less trousers to avoid entry of sparks and slag.

- Wear helmet with safety goggles and glasses with side shields underneath, appropriate filter lenses or plates (protected by clear cover glass). This is a **MUST** for welding to protect the eyes from radiant energy and flying metal. Replace cover glass when broken, pitted, or spattered.

- Avoid oil or greasy clothing. A spark may ignite them. Hot metal such as electrode stubs and workpieces should never be handled without gloves.

- First-aid facilities and a qualified first-aid person should be available for each shift unless medical facilities are close by for immediate treatment of flash burns of the eyes and skin burns.

- Ear plugs should be worn when working on overhead or in a confined space. A hard hat should be worn when others work overhead.

- Flammable hair preparations should not be used by persons intending to weld or cut.

7.3 Fumes

 Welding operations give off harmful fumes and metal dusts which may be hazardous to your health, therefore:

- Work in a well-ventilated area.
- Keep your head out of fumes.
- In closed areas, use suitable exhaust fans.
- If ventilation is not enough, use breathing sets approved for this procedure.
- Clean the material to be welded of any solvents or halogen degreasers giving rise to toxic gases. Some chlorine solvents may decompose with the radiation emitted by the arc, and create phosgene gas.

- Do not weld plated metals or those containing lead, graphite, cadmium, zinc, chrome, mercury or beryllium, unless you have the proper breathing set.

- The electric arc creates ozone. A long exposure to high concentrations may cause headaches, nasal, throat and eye irritation as well as serious congestions and chest pains.

IMPORTANT: DO NOT USE OXYGEN FOR VENTILATION.

- Gas leaks in a confined space should be avoided. Leaked gas in large quantities can change oxygen concentration dangerously. Do not bring gas cylinders into a confined space.
- **DO NOT WELD** where solvent vapors can be drawn into the welding atmosphere or where the radiant energy can penetrate to atmospheres containing even minute amounts of trichloroethylene or perchloroethylene.

7.4 Explosions

 Do not weld above or near containers under pressure.

- Do not weld in environments containing explosive dusts, gases or vapours.

This welding machine uses inert gases such as CO₂, ARGON, or a mixture of ARGON + CO₂ for the protection of the arc, thus you should take special precautions:

A) CYLINDERS

- Do not directly connect cylinder to the machine gas hose without a pressure regulator.
- Handle or use pressure cylinders in conformity with the existing rules.

- Do not use leaking or damaged cylinders.
- Do not use cylinders which are not well secured.
- Do not carry cylinders without the protection of the installed valve.
- Do not use cylinders whose content has not been clearly identified.
- Never lubricate cylinder valves with oil or grease.
- Do not put the cylinder in electrical contact with the arc.
- Do not expose cylinders to excessive heat, sparks, molten slags or flame.
- Do not tamper with the cylinder valves.
- Do not try to loosen tight valves by means of hammers, keys, or any other object.
- **NEVER DEFACE** or alter name, number, or other markings on a cylinder. It is illegal and hazardous.
- Do not lift cylinders off the ground by their valves or caps, or by chains, slings or magnets.
- Never try to mix any gases in a cylinder.
- Never refill any cylinder.
- Cylinder fittings should never be modified or exchanged.

B) PRESSURE REGULATORS

- Keep pressure regulators in good condition. Damaged regulators may cause damages or accidents, they should only be repaired by skilled personnel.
- Do not use regulators for gases other than those for which they are manufactured.
- Never use a leaking or damaged regulator.
- Never lubricate regulators with oil or grease.

C) HOSES

- Replace hoses which appear damaged.
- Keep hoses unwound in order to avoid bending.
- Keep the excess hose wound and out of the working area in order to avoid any damage.

7.5 Radiations

 Ultra-violet radiation created by the arc may damage your eyes and burn your skin. Therefore:

- Wear proper clothing and helmet.
- Do not use contact lenses!! The intense heat coming from the arc may cause them to stick to the cornea.
- Use masks with grade DIN 10 or DIN 11 safety lenses at the least.
- Protect people in the surrounding welding area. Remember: the arc may dazzle or damage the eyes. It is considered dangerous up to a distance of 15 meters (50 feet). Never look at the arc with the naked eye.
- Prepare the welding area so as to reduce reflection and transmission of ultra-violet radiation. Paint walls and exposed surfaces in black to reduce reflection, install sheathings or curtains to reduce ultra-violet transmissions.
- Replace mask lenses whenever damaged or broken.

7.6 Electric shock

 Electric shock can kill.

All electric shocks are potentially fatal.

- Do not touch live parts.
- Insulate yourself from the piece to be cut and from the ground by wearing insulated gloves and clothing.
- Keep garments (gloves, shoes, hats, clothing) and body dry.
- Do not work in humid or wet areas.
- Avoid touching the piece to be welded.
- Should you work close to or in a dangerous area, use all possible precautions.
- If you should feel even the slightest electric shock sensa-

tion, stop welding immediately. Do not use the machine until the problem is identified and solved.

- Always fit an automatic wall switch with adequate power, possibly close to the machine, allowing you to immediately switch the machine off in case of an emergency.
- Frequently inspect the power supply cable.
- Disconnect power supply cable from mains before replacing cables or before removing unit covers.
- Do not use the unit without protection covers.
- Always replace any damaged parts of the unit, with original material.
- Never disconnect unit safety devices.
- Make sure that the power supply line is equipped with an efficient earth plug.
- Make sure that the work bench and the workpiece are connected to an efficient earth plug.
- Any maintenance should only be carried out by qualified personnel aware of the risks due to dangerous voltages necessary for the operation of the unit.

7.7 Pace maker

- Magnetic fields from high currents can affect pacemaker operation. Persons wearing electronic life support equipment (pacemaker) should consult their doctor before going near arc welding, gouging or spot welding operations.

7.8. Caution! Welding wire can cause puncture wounds.

- Do not press gun trigger until instructed to do so.
- Do not point gun toward any part of the body, other people, or any metal when threading welding wire.

7.9. Moving parts can cause injury.

Moving parts, such as fans, can cut fingers and hands and catch loose clothing.

- Keep all doors, panels, covers, and guards closed and securely in place.
- Have only qualified people remove guards or covers for maintenance and troubleshooting as necessary.
- Keep hands, hair, loose clothing, and tools away from moving parts.
- Reinstall panels or guards and close doors when servicing is finished and before starting the machine.

7.10 Noise



These power source alone do not produce noise levels exceeding 80 dB. The welding procedure, however, may produce noise levels in excess of 80 dB. In which case the machine operator must take the necessary safety precautions as prescribed by the national safety regulation.

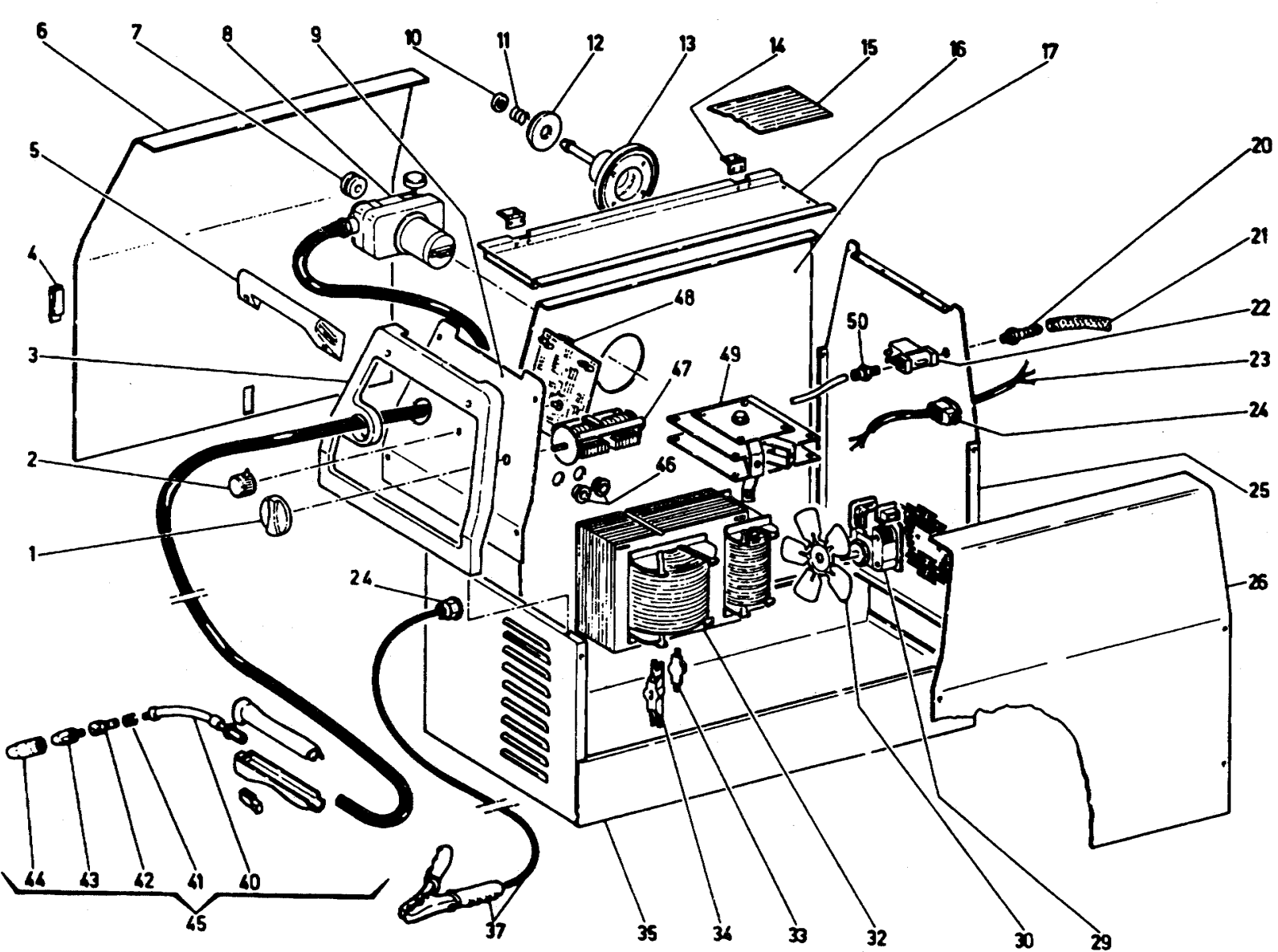

M1184, 83-318, MB135

M12184, MB135, 83-318

Item	Lincoln Stock #	Catalog #	Description
1	S26399-1	246945	Knob
2		246946 (3055121)	Knob
3		246947	Frame
4	S26400-1	246948	Latch
5		246949 (3055176)	Handle
6		246950	Hinged Side Panel
7	310-210-666	246951	Drive Roller
8	216-116-000	246952	Wire Feed Motor
9		251049, 251050	Control Panel
10	S26399-8	251030	Ring
11	S26399-9	251031	Spring
12	S26399-7	251027	Coil Support Spacer
13	S26399-6	251022	Coil Support
14	S26399-2	246958	Hinged Side Panel
15		246959	Rubber Mat
16		246961	Cover
17		246962	Center Divider
20		B7107370 (3160016)	Hose Barb Joint
21	059-245-666	246169	Gas Hose
22	246-530-666	251036	Solenoid Valve
23	S26399-19	B7023370	Power Cord
24		B7022370	Strain Relief
25		246971	Back Panel
26		246972	Fixed Side Panel

Item	Lincoln Stock #	Catalog #	Description
29		251037 (3165079)	Fan Motor
30		246193 (3065101)	Fan Blade
32		251044 (5600717)	Transformer
33	S26399-21	B7065370	Thermostat
34	S26399-20	B7028370	Thermostat Support
35		251048, 251020	Undercarriage
37	S26399-3	246983	Ground Cable
40	334-628-000	B7123370	Gooseneck
41	334-172-000	B7124370	Spring
42	334-632-000	246311	Diffuser
43	KP11-25, KH710	43090, 334-159-300, KP2039-1B1, M15522	0.025 Contact Tips
	KP11-30, KH711	43100, 334-160-300, KP2039-2B1, M15523	0.030 Contact Tips
	KP11-35, KH712	43110, 334-161-300, KP2039-3B1, M15524	0.035 Contact Tips
44	334-164-400	M15520	Nozzle
45	334-634-000	247008	Torch Assembly
46		246993 (3180039)	Cable Outlet
47	S26399-4	246994	Switch
48	880-595-000	251045	Circuit Board
49	S26399-5	246996	Rectifier
50		246997 (3160050)	Fitting

Not Shown

51	334-637-000	246199	Steel Liner
52	334-645-000	M15520	Teflon Liner

2/8/2007

Model	Primary Input	Input Plug	Duty Cycle at Rated Output
M12184	120V, 23 amp	15A	15%

Rated Output	Voltage Settings	Agency Listing	Max Output
90 amps	7	CSA	135 amps

	L	L1	N	N3	N4	N5	N6
pos.0							
pos.1	•						•
pos.2	•						•
pos.3	•						•
pos.4	•						•
pos.5	•						•
pos.6	•						•
pos.7	•						•

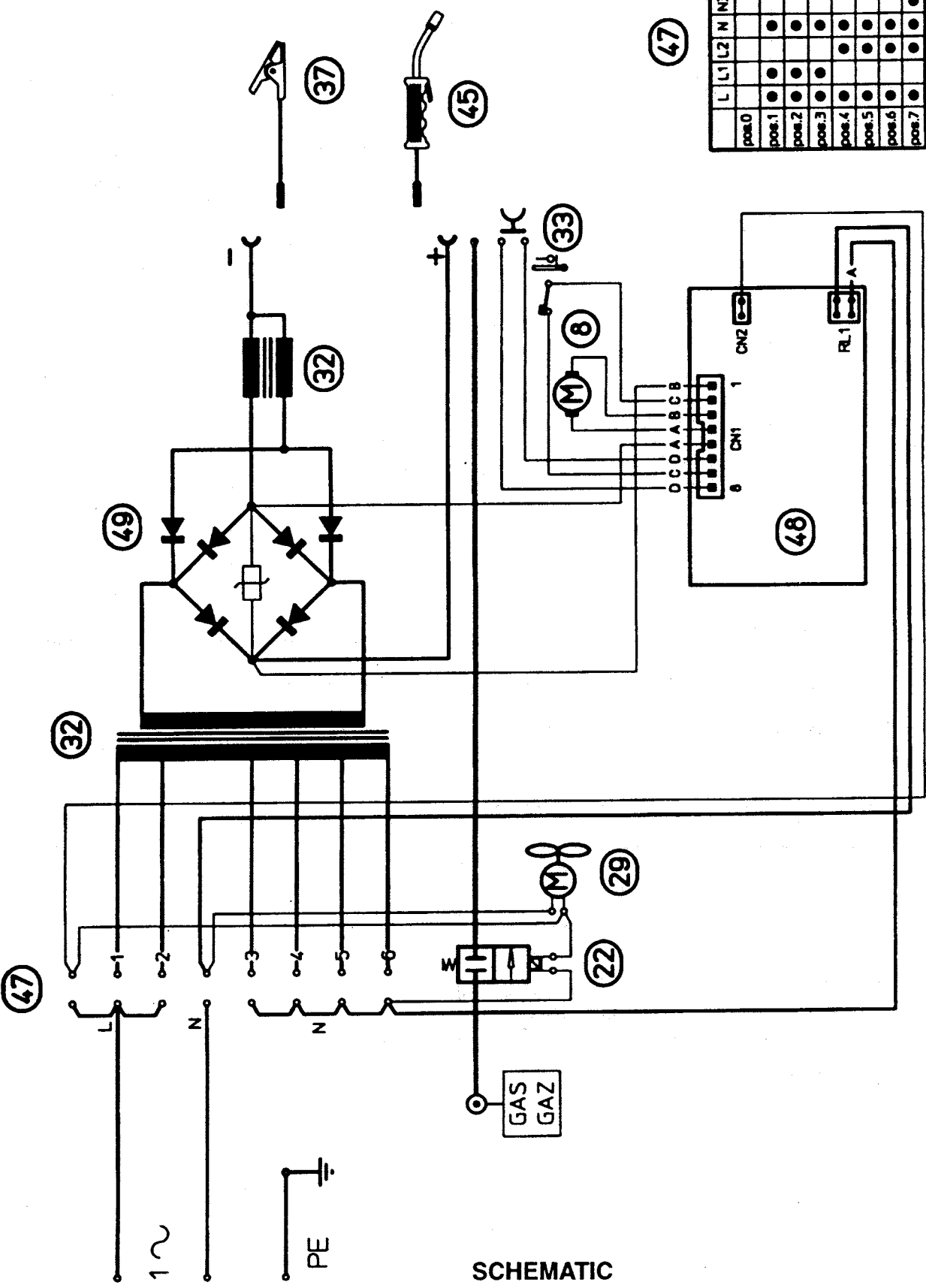

SCHMATIC