



PRO-CUT® 25

NOTE: This manual will cover most of the troubleshooting and repair procedures for the code numbers listed. Some variances may exist when troubleshooting/repairing later code numbers.

For use with machines having Code Numbers:

10661

SERVICE MANUAL

WARNING

PLASMA CUTTING or GOUGING can be hazardous.

PROTECT YOURSELF AND OTHERS FROM POSSIBLE SERIOUS INJURY OR DEATH. KEEP CHILDREN AWAY. PACEMAKER WEARERS SHOULD CONSULT WITH THEIR DOCTOR BEFORE OPERATING.

Read and understand the following safety highlights. For additional safety information it is strongly recommended that you purchase a copy of "Safety in Welding & Cutting - ANSI Standard Z49.1" from the American Welding Society, P.O. Box 351040, Miami, Florida 33135 or CSA Standard W117.2.

BE SURE THAT ALL INSTALLATION, OPERATION, MAINTENANCE, AND REPAIR PROCEDURES ARE PERFORMED ONLY BY QUALIFIED INDIVIDUALS.



ELECTRIC SHOCK can kill.

1.a. The electrode and work (or ground) circuits are electrically "hot" when the power source is on. Do not touch these "hot" parts with your bare skin or wet clothing. Wear dry, hole-free gloves to insulate hands.

- 1.b. When the power source is operating voltages in excess of 250 volts are produced. This creates the potential for serious electrical shock - potentially even fatal.
- 1.c. Insulate yourself from work and ground using dry insulation. When cutting or gouging in damp locations, on metal framework such as floors, gratings or scaffolds and when in positions such as sitting or lying, make certain the insulation is large enough to cover your full area of physical contact with work and ground.
- 1.d. Always be sure the work cable makes a good electrical connection with the metal being cut or gouged. The connection should be as close as possible to the area being cut or gouged.
- 1.e. Ground the work or metal to be cut or gouged to a good electrical (earth) ground.
- 1.f. Maintain the plasma torch, cable and work clamp in good, safe operating condition. Replace damaged insulation.
- 1.g. Never dip the torch in water for cooling or plasma cut or gouge in or under water.
- 1.h. When working above floor level, protect yourself from a fall should you get a shock.
- 1.i. Operate the pilot arc with caution. The pilot arc is capable of burning the operator, others or even piercing safety clothing.
- 1.j. Also see Items 4c and 6.

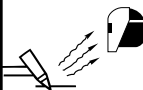

ARC RAYS can burn.

2.a. Use safety glasses and a shield with the proper filter and cover plates to protect your eyes from sparks and the rays of the arc when performing or observing plasma arc cutting or gouging. Glasses, headshield and filter lens should conform to ANSI Z87.1 standards.

- 2.b. Use suitable clothing including gloves made from durable flame-resistant material to protect your skin and that of your helpers from the arc rays.
- 2.c. Protect other nearby personnel with suitable non-flammable screening and/or warn them not to watch the arc nor expose themselves to the arc rays or to hot spatter or metal.



FUMES AND GASES can be dangerous.

3.a. Plasma cutting or gouging may produce fumes and gases hazardous to health. Avoid breathing these fumes and gases. When cutting or gouging, keep your head out of the fumes. Use enough ventilation and/or exhaust at the arc to

keep fumes and gases away from the breathing zone. **When plasma cutting or gouging on lead or cadmium plated steel and other metals or coatings which produce highly toxic fumes keep exposure as low as possible and below Threshold Limit Values (TLV) using local exhaust or mechanical ventilation. In confined spaces or in some circumstances, outdoors, a respirator may be required. Additional precautions are also required when plasma cutting or gouging on galvanized steel.**

- 3.b. The operation of plasma cutting or gouging fume control equipment is affected by various factors including proper use and positioning of the equipment, maintenance of the equipment and the specific procedure and application involved. Worker exposure level should be checked upon installation and periodically thereafter to be certain it is within applicable OSHA PEL and ACGIH TLV limits.
- 3.c. Do not use plasma cutting or gouging equipment in locations near chlorinated hydrocarbon vapors coming from degreasing, cleaning or spraying operations. The heat and rays of the arc can react with solvent vapors to form phosgene, a highly toxic gas, and other irritating products.
- 3.d. Gases used for plasma cutting and gouging can displace air and cause injury or death. Always use enough ventilation, especially in confined areas, to insure breathing air is safe.
- 3.e. Read and understand the manufacturer's instructions for this equipment and follow your employer's safety practices.



CUTTING SPARKS can cause fire or explosion.

4.a. Remove fire hazards from the plasma cutting or gouging area. If this is not possible, cover them to prevent the cutting or gouging sparks from starting a fire. Remember that welding sparks and hot materials from plasma cutting or gouging can easily go through small cracks and openings to adjacent areas. Avoid cutting or gouging near hydraulic lines. Have a fire extinguisher readily available.

- 4.b. Where compressed gases are to be used at the job site, special precautions should be used to prevent hazardous situations. Refer to "Safety in Welding and Cutting" (ANSI Standard Z49.1) and the operating information for the equipment being used.

- 4.c. When not cutting or gouging, make certain no part of the electrode circuit is touching the work or ground. Accidental contact can cause overheating and create a fire hazard.
- 4.d. Do not cut or gouge tanks, drums or containers until the proper steps have been taken to insure that such procedures will not cause flammable or toxic vapors from substances inside. They can cause an explosion even though they have been "cleaned." For information purchase "Recommended Safe Practices for the Preparation for Welding and Cutting of Containers and Piping That Have Held Hazardous Substances", AWS F4.1 from the American Welding Society (see address above).
- 4.e. Vent hollow castings or containers before heating, cutting or gouging. They may explode.
- 4.f. Do not fuel engine driven equipment near area where plasma cutting or gouging.
- 4.g. Sparks and spatter are thrown from the plasma arc. Wear safety glasses, ear protection and oil free protective garments such as leather gloves, heavy shirt, cuffless trousers, high shoes and a cap over your hair. Wear ear plugs when cutting or gouging out of position or in confined places. Always wear safety glasses with side shields when in a cutting or gouging area.
- 4.h. Connect the work cable to the work as close to the cutting or gouging area as practical. Work cables connected to the building framework or other locations away from the cutting or gouging area increase the possibility of the current passing through lifting chains, crane cables or other alternate circuits. This can create fire hazards or overheat lifting chains or cables until they fail.



CYLINDER may explode if damaged.

5.a. Use only compressed gas cylinders containing the correct gas for the process used and properly operating regulators designed for the gas and pressure used. All hoses, fittings, etc. should be suitable for the application and maintained in good condition.

- 5.b. Always keep cylinders in an upright position securely chained to an undercarriage or fixed support.
- 5.c. Cylinders should be located:
- Away from areas where they may be struck or subjected to physical damage.
 - A safe distance from plasma cutting or gouging, arc welding operations and any other source of heat, sparks, or flame.
- 5.d. Never allow any part of the electrode, torch or any other electrically "hot" parts to touch a cylinder.
- 5.e. Keep your head and face away from the cylinder valve outlet when opening the cylinder valve.
- 5.f. Valve protection caps should always be in place and hand tight except when the cylinder is in use or connected for use.
- 5.g. Read and follow the instructions on compressed gas cylinders, associated equipment, and CGA publication P-1, "Precautions for Safe Handling of Compressed Gases in Cylinders," available from the Compressed Gas Association 1235 Jefferson Davis Highway, Arlington, VA 22202.



FOR ELECTRICALLY powered equipment.

- 6.a. Turn off input power using the disconnect switch at the fuse box before working on the equipment.
- 6.b. Install equipment in accordance with the U.S. National Electrical Code, all local codes and the manufacturer's recommendations.
- 6.c. Ground the equipment in accordance with the U.S. National Electrical Code and the manufacturer's recommendations.



PLASMA ARC can injure.

- 7.a. Keep your body away from nozzle and plasma arc.
- 7.b. Operate the pilot arc with caution. The pilot arc is capable of burning the operator, others or even piercing safety clothing.



ELECTRIC AND MAGNETIC FIELDS may be dangerous

8.a. Electric current flowing through any conductor causes localized Electric and Magnetic Fields (EMF). Cutting or gouging current creates EMF fields around torch cables and cutting machines.

8.b. EMF fields may interfere with some pacemakers, so operators having a pacemaker should consult their physician before cutting or gouging.

- 8.c. Exposure to EMF fields during cutting or gouging may have other health effects which are now not known.
- 8d. All operators should use the following procedures in order to minimize exposure to EMF fields from the cutting or gouging circuit:
- 8.d.1. Route the torch and work cables together - Secure them with tape when possible.
 - 8.d.2. Never coil the torch cable around your body.
 - 8.d.3. Do not place your body between the torch and work cables. If the torch cable is on your right side, the work cable should also be on your right side.
 - 8.d.4. Connect the work cable to the workpiece as close as possible to the area being cut or gouged.
 - 8.d.5. Do not work next to cutting power source.

PRÉCAUTIONS DE SÛRETÉ

Pour votre propre protection lire et observer toutes les instructions et les précautions de sûreté spécifiques qui paraissent dans ce manuel aussi bien que les précautions de sûreté générales suivantes:

Sûreté Pour Soudage A L'Arc

1. Protégez-vous contre la secousse électrique:
 - a. Les circuits à l'électrode et à la pièce sont sous tension quand la machine à souder est en marche. Eviter toujours tout contact entre les parties sous tension et la peau nue ou les vêtements mouillés. Porter des gants secs et sans trous pour isoler les mains.
 - b. Faire très attention de bien s'isoler de la masse quand on soude dans des endroits humides, ou sur un plancher métallique ou des grilles métalliques, principalement dans les positions assis ou couché pour lesquelles une grande partie du corps peut être en contact avec la masse.
 - c. Maintenir le porte-électrode, la pince de masse, le câble de soudage et la machine à souder en bon et sûr état de fonctionnement.
 - d. Ne jamais plonger le porte-électrode dans l'eau pour le refroidir.
 - e. Ne jamais toucher simultanément les parties sous tension des porte-électrodes connectés à deux machines à souder parce que la tension entre les deux pinces peut être le total de la tension à vide des deux machines.
 - f. Si on utilise la machine à souder comme une source de courant pour soudage semi-automatique, ces précautions pour le porte-électrode s'appliquent aussi au pistolet de soudage.
2. Dans le cas de travail au dessus du niveau du sol, se protéger contre les chutes dans le cas où on recoit un choc. Ne jamais enrouler le câble-électrode autour de n'importe quelle partie du corps.
3. Un coup d'arc peut être plus sévère qu'un coup de soliel, donc:
 - a. Utiliser un bon masque avec un verre filtrant approprié ainsi qu'un verre blanc afin de se protéger les yeux du rayonnement de l'arc et des projections quand on soude ou quand on regarde l'arc.
 - b. Porter des vêtements convenables afin de protéger la peau de soudeur et des aides contre le rayonnement de l'arc.
 - c. Protéger l'autre personnel travaillant à proximité au soudage à l'aide d'écrans appropriés et non-inflammables.
4. Des gouttes de laitier en fusion sont émises de l'arc de soudage. Se protéger avec des vêtements de protection libres de l'huile, tels que les gants en cuir, chemise épaisse, pantalons sans revers, et chaussures montantes.
5. Toujours porter des lunettes de sécurité dans la zone de soudage. Utiliser des lunettes avec écrans latéraux dans les zones où l'on pique le laitier.

6. Eloigner les matériaux inflammables ou les recouvrir afin de prévenir tout risque d'incendie dû aux étincelles.
7. Quand on ne soude pas, poser la pince à un endroit isolé de la masse. Un court-circuit accidentel peut provoquer un échauffement et un risque d'incendie.
8. S'assurer que la masse est connectée le plus près possible de la zone de travail qu'il est pratique de le faire. Si on place la masse sur la charpente de la construction ou d'autres endroits éloignés de la zone de travail, on augmente le risque de voir passer le courant de soudage par les chaînes de levage, câbles de grue, ou autres circuits. Cela peut provoquer des risques d'incendie ou d'échauffement des chaînes et des câbles jusqu'à ce qu'ils se rompent.
9. Assurer une ventilation suffisante dans la zone de soudage. Ceci est particulièrement important pour le soudage de tôles galvanisées plombées, ou cadmiées ou tout autre métal qui produit des fumées toxiques.
10. Ne pas souder en présence de vapeurs de chlore provenant d'opérations de dégraissage, nettoyage ou pistolage. La chaleur ou les rayons de l'arc peuvent réagir avec les vapeurs du solvant pour produire du phosgène (gas fortement toxique) ou autres produits irritants.
11. Pour obtenir de plus amples renseignements sur la sûreté, voir le code "Code for safety in welding and cutting" CSA Standard W 117.2-1974.

PRÉCAUTIONS DE SÛRETÉ POUR LES MACHINES À SOUDER À TRANSFORMATEUR ET À REDRESSEUR

1. Relier à la terre le châssis du poste conformément au code de l'électricité et aux recommandations du fabricant. Le dispositif de montage ou la pièce à souder doit être branché à une bonne mise à la terre.
2. Autant que possible, l'installation et l'entretien du poste seront effectués par un électricien qualifié.
3. Avant de faire des travaux à l'intérieur de poste, la débrancher à l'interrupteur à la boîte de fusibles.
4. Garder tous les couvercles et dispositifs de sûreté à leur place.

PRO-CUT® 25

LINCOLN
ELECTRIC

	Page
Safety	i-iii
<hr/>	
Installation	Section A
Technical Specifications	A-2
Safety Precautions	A-3
Select Proper Location	A-3
Stacking	A-3
Tilting	A-3
High Frequency Interference Protection	A-3
Input Electrical Connections	A-3
Gas Input Connections	A-4
Output Connections	A-5
Torch	A-5
<hr/>	
Operation	Section B
Safety Precautions	B-2
Description	B-2
Preheating Temperature	B-2
User Responsibilities	B-3
Operational Features and Controls	B-3
Design Features and Advantages	B-3
Cutting Capability	B-4
Consumable Life	B-4
Limitations	B-5
Controls and Settings	B-5
Pilot Arc Discussion	B-6
Procedure Recommendations	B-7
General	B-7
Suggestions For Extra Utility From The PRO-CUT® System	B-7
<hr/>	
Accessories	Section C
<hr/>	
Maintenance	Section D
<hr/>	
Theory of Operation	Section E
<hr/>	
Troubleshooting and Repair	Section F
How to Use Troubleshooting Guide	F-2
Troubleshooting Guide	F-4
Test Procedures	F-9
Replacement Procedures	F-29
<hr/>	
Electrical Diagrams	Section G
<hr/>	
Parts Manual (PRO-CUT® 25)	P-357 Series
Cutting Torch	P-210-U

NOTES

Return to Section TOC Return to Section TOC Return to Section TOC Return to Section TOC
Return to Master TOC Return to Master TOC Return to Master TOC Return to Master TOC

PRO-CUT® 25



TABLE OF CONTENTS - INSTALLATION SECTION -

Installation

Technical Specifications.....	A-2
Safety Precautions.....	A-3
Select Proper Location	A-3
Stacking	A-3
Tilting.....	A-3
High Frequency Interference Protection.....	A-3
Input Electrical Connections	A-3
Gas Input Connections	A-4
Output Connections	A-5
Torch	A-5

Return to Master TOC

Return to Master TOC

Return to Master TOC

Return to Master TOC

PRO-CUT® 25



TECHNICAL SPECIFICATIONS - PRO-CUT® 25 (K1756-1)

INPUT - SINGLE PHASE / 60 HERTZ ONLY

<u>Standard Voltage</u>	<u>1Ø Input Current at Rated Output</u>
115/230/1/50/60Hz	115 V : 15 A @ 20% 115 V : 26.7A @ 60% 115 V : 37.7A @ 35% 230 V : 15 A @ 100% 230 V : 19 A @ 60%

RATED OUTPUT

<u>Duty Cycle</u>	<u>AMPS</u>
20% on 115 V	15 A
60% on 115 V	20 A
100% on 230 V	20 A
35% on 115 V	25 A
60% on 230 V	25 A

OUTPUT

<u>Current Range</u>	<u>Open Circuit Voltage</u>	<u>Pilot Current</u>
12-25 Amps	400 VDC	12 Amps

REQUIRED GAS FLOW RATE

REQUIRED GAS INLET PRESSURE

55 PSI @ 240 SCFH (3.8 Bar. @ 6800 LHR)	65 to 150 PSI (4.5 Bar. TO 10.3 Bar.)
---------------------------------------------	------------------------------------------

RECOMMEND INPUT WIRE AND FUSE SIZES

For all plasma cutting applications
Based on U.S. National Electrical Code
Ambient Temperature 30°C or Less

Output	AC Input Voltage at 50/60 Hertz	Input Cord Plug Size	Fuse (Super Lag) Circuit Breaker (Delay Type)	Type 75°C Copper Wire in Conduit AWG (IEC) Sizes	
				2 Input Supply Wires	1 Ground Wire
25 A	230V-1Ø	6-20P or 6-30P or 6-50P	20 AMPS	#14 (2.5 mm ²)	#14 (2.5 mm ²)
15 A	115V-1Ø	5-15P* or 5-20P* or 5-30P or 5-50P 5-20P* or 5-30P or 5-50P 5-30P or 5-50P	15 AMPS	#12 (4 mm ²)	#12 (4 mm ²)
20 A	115V-1Ø		20 AMPS	#12 (4 mm ²)	#12 (4 mm ²)
25 A	115V-1Ø		30 AMPS	#12 (4 mm ²)	#12 (4 mm ²)

PHYSICAL DIMENSIONS

<u>Height</u>	<u>Width</u>	<u>Depth</u>	<u>Weight Including Torch Cable</u>
10.2 in. 260 mm	6.3 in. 160 mm	16.1 in. 410 mm	35 lbs. 15.9 kg.

* Included with machine

PRO-CUT® 25



Return to Section TOC

Return to Master TOC

Read entire Installation Section before installing the **PRO-CUT® 25**.

SAFETY PRECAUTIONS

⚠ WARNING

ELECTRIC SHOCK CAN KILL.



- Only qualified personnel should install this machine.
- Turn the input power OFF at the disconnect switch or fuse box and discharge input capacitors before working inside the equipment.
- Do not touch electrically hot parts.
- Turn the **PRO-CUT®** Power Switch OFF when connecting power cord to input power.

SELECT PROPER LOCATION

Place the **PRO-CUT® 25** where clean cool air can freely circulate in and out the side louvers. Dirt, dust or any foreign material that can be drawn into the machine should be kept at a minimum. Failure to observe these precautions can result in excessive operating temperatures and nuisance shutdown of the machine.

A source of clean, dry air or nitrogen must be supplied to the **PRO-CUT® 25**. Oil in the air is a severe problem and must be avoided. The supply pressure must be between 80 and 150 psi. The flow rate is approximately 4.0 cfm (113 l/min.). Failure to observe these precautions could result in excessive operating temperatures or damage to the torch.

STACKING

The **PRO-CUT® 25** cannot be stacked.

TILTING

The **PRO-CUT® 25** must be placed on a stable, level surface so it will not topple over.

HIGH FREQUENCY INTERFERENCE PROTECTION

The **PRO-CUT® 25** employs a touch start mechanism for arc initiation which eliminates high frequency emissions from the machine as compared with spark gap and solid state type high frequency generators. Keep in mind, though, that these machines may be used in an environment where other high frequency generating machines are operating. By taking the following steps, high frequency interference into the **PRO-CUT®** can be minimized

- (1) Make sure the power supply chassis is connected to a good earth ground. The work terminal ground does NOT ground the machine frame.
- (2) Keep the work clamp isolated from other work clamps that have high frequency.
- (3) If the work clamp cannot be isolated, then keep the clamp as far as possible from other work clamp connections.
- (4) When the machine is enclosed in a metal building, several good earth driven electrical grounds around the periphery of the building are recommended.

Failure to observe these recommended installation procedures may cause improper function of the **PRO-CUT®** or possibly even damage to the control system or power supply components.

INPUT ELECTRICAL CONNECTIONS

The **PRO-CUT® 25** is rated for 115VAC or 230VAC inputs and will automatically reconnect for the supplied voltage. The machine is shipped from the factory for operation on 115VAC 15 amp circuits. Use on 15 amp branch circuits will limit cutting output as indicated by the graphics around the output knob. If the output is set at 20 amps or greater, the input fuse or circuit breaker may “blow” in roughly 30 seconds or less (depending on fuse or circuit breaker type).

To achieve 20 amp output with 115VAC input, replace the 15 amp plug on the input cord with the supplied 20 amp plug, and connect the unit to a 20 amp branch circuit with super lag fuses (or equivalent breaker). To install the supplied 20 amp plug: Connect the white (neutral) wire under terminal clamp with silver screw, and black (hot) wire under terminal clamp with brass screw. Connect green wire under terminal clamp with green screw.

PRO-CUT® 25



⚠ WARNING

- Failure to wire as instructed may cause personal injury or damage to equipment.
- To be installed or checked by an electrician or qualified person only.

Use of normal 20 amp household breakers may result in over current trips. If breaker trips occur, reduce the cutting current output until nuisance trips stop.

To achieve the full 25 amp output capability of the machine with 115 VAC input, remove the 15 amp or 20 amp plug on the input cord and install a 30 amp or 50 amp plug designed for 115 VAC (NEMA style 5-30P or 5-50P). Follow the instructions included with the plug. Connect to an appropriate branch circuit with a mating receptacle.

The **PRO-CUT**® 25 performs best when connected to 230VAC inputs. To change over to 230VAC operation, install a 230VAC plug with a current rating equal to or greater than 20 amps.

For use on engine drives, keep in mind the above input draw restrictions and the following precaution.

The **PRO-CUT**® 25 can be operated on engine driven generators as long as the 230 volt auxiliary meets the following conditions:

- The AC waveform peak voltage is below 400 volts*.
- The AC waveform frequency is between 45 and 65 Hz.
- The RMS voltage of the AC waveform is always greater than 208VAC *.

* for 115 VAC input divide these values in half

The following Lincoln engine drives meet these conditions when run in the high idle mode:

Ranger 200 & 250 engine drives
Commander 300, 400, & 500 engine drives

Some engine drives do not meet these conditions (eg Miller Bobcats, etc). Operation of the **PRO-CUT**® 25 is not recommended on engine drives not conforming to these conditions. Such combinations may overvoltage the **PRO-CUT**® 25 power source.

GAS INPUT CONNECTIONS

Supply the **PRO-CUT**® 25 with clean compressed air or nitrogen.

- Supply pressure must be between 80 psi and 150 psi.
- Flow rate should be approximately 4.0 cfm (113 l/min.).

NOTE: Oil in the air supply to the **PRO-CUT**® 25 can cause severe problems. Use only a clean air supply.

- Compressed gas can be supplied either through the air fitting supplied with the machine or through the 1/4-19 BSPF thread at the rear of the machine. To use the air fitting supplied with the machine (packaged in the consumable kit), apply teflon tape to the fitting threads and install the fitting in the port at the rear of the machine.
- If compressed air is being used, it is highly recommended that an inline filter be installed in the air supply line ahead of the air connection to the **PRO-CUT**® 25.
- A standard nominal 5 micron inline filter is recommended; however, for optimum performance, select a prefilter with a 3 micron absolute rating. If these filter ratings are unavailable, anything with a rating less than, or equal to, 20 micron would be acceptable to use. In line filter elements will generally filter the air with little restriction to the airflow until the element is about 75% contaminated. After this point, there will be a noticeable pressure drop in the line. Filter elements should be replaced when a pressure drop of 8-10 psi is indicated; however, for optimum performance of the **PRO-CUT**® 25, the filter element should be replaced at or before the pressure drop reaches 8 psi. Be sure to select a filter that will accommodate the necessary flow rating for the **PRO-CUT**® 25 as specified in the Installation section of this instruction manual under the Gas Input Connections heading.

PRO-CUT® 25



INSTALLATION

NOTE: When using nitrogen gas from a cylinder, the cylinder must have a pressure regulator.

- Maximum psi from a nitrogen gas cylinder to the **PRO-CUT**[®] 25 regulator should never exceed 150 psi.
- Install a hose between the nitrogen gas cylinder regulator and the **PRO-CUT**[®] 25 gas inlet.

⚠ WARNING

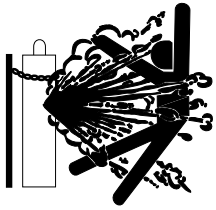

CYLINDER could explode if damaged.

- Keep cylinder upright and chained to a fixed support.

- Keep cylinder away from areas where it could be damaged.
- Never lift machine with cylinder attached.
- Never allow the cutting torch to touch the cylinder.
- Keep cylinder away from live electrical parts.
- Maximum inlet pressure 150 psi.

OUTPUT CONNECTIONS

Torch

The **PRO-CUT**[®] 25 is sent from the factory with a 15' PCT 20 cutting torch installed. Additional cutting torches can be ordered from the K1615 series. Hand-held torches come with 15' or 25' cables.

PRO-CUT[®] 25



NOTES

Return to Section TOC
Return to Master TOC

Return to Section TOC
Return to Master TOC

Return to Section TOC
Return to Master TOC

Return to Section TOC
Return to Master TOC

PRO-CUT® 25



TABLE OF CONTENTS - OPERATION SECTION -

Operation	Section B
Safety Precautions	B-2
Description	B-2
Preheating Temperature	B-2
User Responsibility	B-3
Operational Features and Controls.....	B-3
Design Features and Advantages.....	B-3
Cutting Capability	B-4
Consumable Life	B-4
Limitations	B-5
Controls and Settings.....	B-5
Pilot Arc Discussion	B-6
Procedure Recommendations.....	B-7
General	B-7
Suggestions for Extra Utility From the PRO-CUT® System.....	B-7

Return to Master TOC

Return to Master TOC

Return to Master TOC

Return to Master TOC

Read and understand this entire section before operating the machine.

SAFETY PRECAUTIONS

⚠ WARNING



ELECTRIC SHOCK can kill.

- Do not touch electrically live parts or electrode with skin or wet clothing.
- Insulate yourself from work and ground.
- Always wear dry insulating gloves.



FUMES AND GASES can be dangerous.

- Keep your head out of fumes.
- Use ventilation or exhaust to remove fumes from breathing zone.



WELDING, CUTTING and GOUGING SPARKS can cause fire or explosion

- Keep flammable material away.
- Do not weld, cut or gouge on containers that have held combustibles.

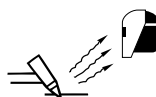

ARC RAYS can burn.

- Wear eye, ear and body protection.

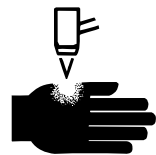

PLASMA ARC can injure

- Keep your body away from nozzle and plasma arc.
- Operate the pilot arc with caution. The pilot arc is capable of burning the operator, others or even piercing safety clothing.

Observe additional Safety Guidelines detailed in the beginning of this manual.

DESCRIPTION

The **PRO-CUT® 25** is a constant current, continuous control plasma cutting power source. It provides superior and reliable starting characteristics, cutting visibility and arc stability. The control system has a safety mechanism to insure that the nozzle and electrode are in place before cutting or gouging. This is extremely important due to the high voltages involved.

The **PRO-CUT® 25** comes standard with an air regulator and pressure gauge. The machine also comes with an input power cord. Hand-held torches are available in 15' or 25' cable. Consumables are included with each **PRO-CUT®** purchase so that cutting can begin right out of the box. Consumables can also be ordered as individual packages.

The **PRO-CUT® 25** initiates the plasma arc with a simple, yet reliable, touch start mechanism. This system eliminates many of the failure problems associated with high-frequency start systems.

PREHEAT TEMPERATURE FOR PLASMA CUTTING

Preheat temperature control is not necessary in most applications when plasma arc cutting or gouging. Preheat temperature control may be necessary on high carbon alloy steels and heat treated aluminum for crack resistance and hardness control. Job conditions, prevailing codes, alloy level, and other considerations may also require preheat temperature control. The following minimum preheat temperature is recommended as a starting point. Higher temperatures may be used as required by the job conditions and/or prevailing codes. If cracking or excessive hardness occurs on the cut face, higher preheat temperature may be required. The recommended minimum preheat temperature for plate thickness up to 1/2" (12.7mm) is 70°F (21.1°C).

PRO-CUT® 25



USER RESPONSIBILITY

Because design, fabrication, erection and cutting variables affect the results obtained in applying this type of information, the serviceability of a product or structure is the responsibility of the user. Variation such as plate chemistry, plate surface condition (oil, scale), plate thickness, preheat, quench, gas type, gas flowrate and equipment may produce results different than those expected. Some adjustments to procedures may be necessary to compensate for unique individual conditions. Test all procedures duplicating actual field conditions.

OPERATIONAL FEATURES AND CONTROLS

The **PRO-CUT**® 25 comes with an ON/OFF POWER SWITCH, OUTPUT CURRENT CONTROL, and PURGE BUTTON.

DESIGN FEATURES AND ADVANTAGES

The **PRO-CUT**® 25 design makes plasma cutting uncomplicated. This list of design features and advantages will help you understand the machine's total capabilities so that you can get maximum use from your machine.

- Light weight and portable design for industrial use.

- Continuous control, 12 - 25 amps.
- Reliable touch start mechanism for plasma arc initiation.
- Rapid arc restrike for fast cutting of expanded metal.
- Input over voltage protection.
- Bright 3.0 second timed pilot arc.
- Purge momentary push button.
- Air regulator and pressure gage included.
- Parts-in-Place mechanism to detect proper installation of consumables and torch.
- Latching Parts-in-Place mechanism. Requires the operator to turn the machine off and then on to reset.
- Preflow/Postflow timing. Preflow is eliminated if arc is re-initiated in Postflow.
- Thermostatic Protection.
- Solid state over-current protection.
- Automatic reconnect for 115 VAC or 230 VAC inputs.
- Dead front display for machine status.
- Unique electrode and Vortech™ nozzle design for optimum cooling and long life.
- Swirl texture inside Vortech™ nozzle for better starting reliability and higher quality cuts.

PRO-CUT® 25



CUTTING CAPABILITY

The **PRO-CUT**® 25 is rated at 25 amps, at 35% duty cycle on a 10 minute basis. If the duty cycle is exceeded, a thermal protector will shut off the output of the machine until it cools to the normal operating temperature.

Figure B.1 shows the cut capacity of the **PRO-CUT**® 25 when cutting mild steel. (The graph plots cut thickness vs. torch travel speed with a torch standoff of 0.15".)

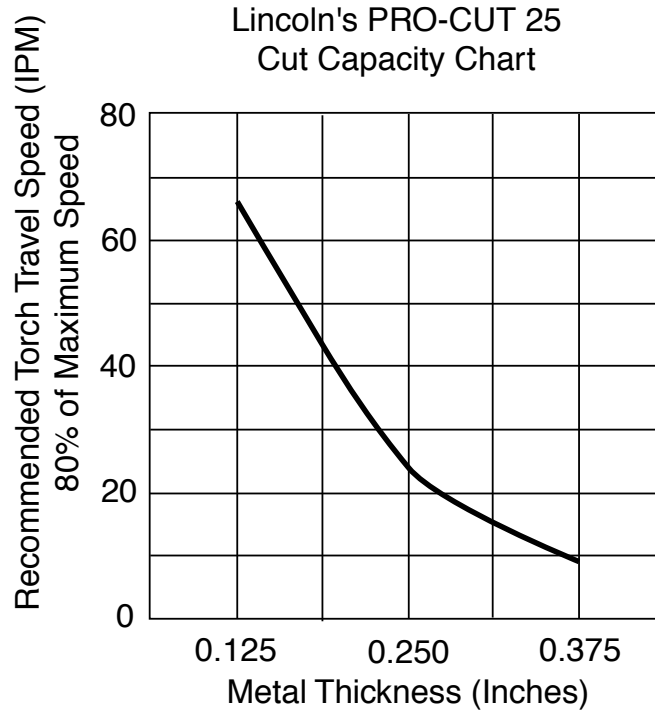

Figure B.1

CONSUMABLE LIFE

The expected life for the **PRO-CUT**® 25's electrode under normal operating conditions is approximately 1000 starts/cuts. An erosion of .060" is typical for end of electrode life, however, the electrode life may last longer. A green and erratic arc will indicate definite electrode failure and the electrode should be replaced immediately.

It is recommended that consumables be replaced in complete sets. (Example: Electrode and Nozzle). This will maximize the performance of the **PRO-CUT**® 25 system.

Return to Section TOC

Return to Section TOC

Return to Section TOC

Return to Section TOC

Return to Master TOC

Return to Master TOC

Return to Master TOC

Return to Master TOC

LIMITATIONS

Do not exceed output current and duty cycle rating of machine. Do not use the **PRO-CUT® 25** for pipe thawing.

CONTROLS AND SETTINGS

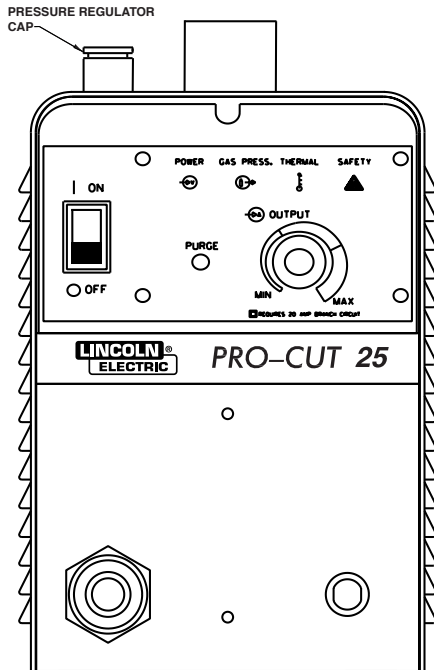

When preparing to cut, position the machine as close to the work as possible. Make sure you have all materials needed to complete the job and have taken all safety precautions. It is important to follow these operating steps each time you use the machine.

- Turn the machine's ON/OFF POWER SWITCH to OFF position.
- Connect the air supply to the machine.
- Turn the main power and the machine power switch on.
 - The fan should start.
 - The pre-charge circuit will operate for 3 seconds, then the green "Power" LED should turn on.
- Be sure that the work lead is clamped to the workpiece before cutting.
- Set the output current control knob at maximum¹ position for higher cutting speed and less dross formation. Reduce the current, if desired to reduce the kerf (cut) width, heat affected zone or travel speed as required.

¹ Maximum output requires a 30 amp input circuit and breaker. Refer to the Technical Specifications for proper input circuit guidelines.

- Push-in and hold the Purge button to check or set the gas pressure. Pull the pressure regulator cap out and turn it to set the pressure.
 - Adjust the gas regulator for 65 PSI for 15' or 25' torches.
 - Release the Purge button.
 - The gas will immediately turn off. The pressure gauge may show an increase in pressure after the air turns off but this is normal. Do NOT reset the pressure while the air is NOT flowing.
- When ready to cut, place the torch near the work, make certain all safety precautions have been taken and pull the trigger.
 - The air will flow for a preflow time of 2 seconds and the pilot arc will start. (Exceptions: the first time that the trigger is pulled after the machine is turned on, or after a thermal tripout, will be ignored. This is a safety feature to prevent the pilot arc from firing unexpectedly or if the torch button is pressed because it is laying up against something. The other exception is if the machine is in postflow, then the preflow time is skipped and the pilot arc will start immediately.)
 - The pilot arc will run for 3.0 seconds and shut off unless the arc is brought in contact with the work and the arc is transferred. Avoid excessive pilot arc time by transferring the arc to the workpiece quickly.
 - When the arc is brought within 1/8" - 1/4" from the work piece: the arc will transfer, the current will ramp to the setting on the control panel, and the cut can last indefinitely (or until the duty cycle of the **PRO-CUT®** is exceeded).

- Pierce the work piece by slowly lowering the torch onto the metal at a 30° angle away from the operator. This will blow the dross away from the torch tip. Slowly rotate the torch to vertical position as the arc becomes deeper.

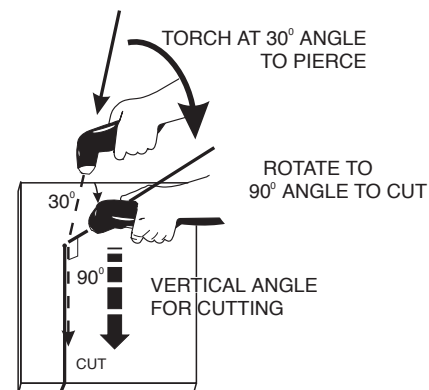

- Keep moving while cutting. Cut at a steady speed without pausing. Maintain the cutting speed so that the arc leg is 10° to 20° behind the travel direction.

PRO-CUT® 25



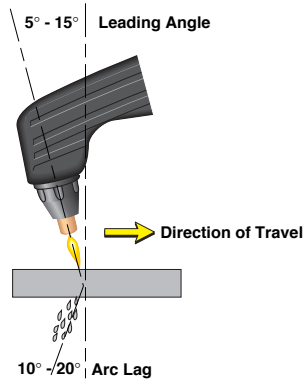

- Use a 5° - 15° leading angle in the direction of the cut.
- Finish the cut to be made and release the trigger.
- When the trigger is released, the arc will stop.
 - The gas will continue to flow for 10 seconds of postflow. If the trigger is activated within this time period, the pilot arc will immediately restart.
- If the dross is difficult to remove, reduce the cutting speed. High speed dross is more difficult to remove than low speed dross.
- The right side of the cut is more square than the left as viewed along the direction of travel.
- Clean spatter and scale from the nozzle frequently.
- If the "SAFETY" LED lights at any time; check the following:
 - Check the assembly of the torch consumables. If they are not properly in place, the machine will not start. **Make sure that the shield cup is hand tight. Do not use pliers or over tighten.**
 - Check the conditions of the inside of the nozzle. If debris has collected, rub the electrode on the inside bottom of the nozzle to remove any oxide layer that may have built up. Refer to "Suggestions for Extra Utility from the PRO-CUT® system".
 - Check the condition of the electrode. If the end has a crater-like appearance, replace it along with the nozzle. The maximum wear depth of the electrode is approximately .062". A green and erratic arc will indicate definite electrode failure and the electrode should be replaced immediately.
- Replace the nozzle when the orifice exit is eroded away or oval shaped.

- After the problem is found, or if there is nothing apparently wrong, reset the machine by turning the power switch OFF and then ON again. (It is possible for electrical noise to trip the safety circuit on rare occasions. This should not be a regular occurrence.)

⚠ WARNING



ELECTRIC SHOCK CAN KILL.

- Turn off machine at the disconnect switch on the front of the machine before tightening, cleaning or replacing consumables.
-
- If the machine does not reset or continues to trip, consult the Troubleshooting Section.
 - Use the proper cutting procedures referred to in Procedure Recommendations.

PILOT ARC DISCUSSION

The PRO-CUT® has a smooth, continuous pilot arc. The pilot arc is only a means of transferring the arc to the workpiece for cutting. Repeated pilot arc starts, in rapid succession, is not recommended as these starts will generally reduce consumable life. Occasionally, the pilot arc may sputter or start intermittently. This is aggravated when the consumables are worn or the air pressure is too high. Always keep in mind that the pilot arc is designed to transfer the arc to the workpiece and not for numerous starts without cutting.

When the pilot arc is started, a slight impulse will be felt in the torch handle. This occurrence is normal and is the mechanism which starts the plasma arc. This impulse can also be used to help troubleshoot a "no start" condition.

PRO-CUT® 25



PROCEDURE RECOMMENDATIONS

When properly used, plasma arc cutting is a very economical process. Improper use will result in a very high operating cost.

General - In All Cases

- Follow safety precautions as printed throughout this operating manual and on the machine.
- If piercing is required, slowly lower the torch at an angle of about 30° to blow the dross away from the torch tip and slowly rotate the torch to a vertical position as the arc becomes deeper. This process will blow a lot of molten metal and dross. Be careful! Blow the dross away from the torch, the operator and any flammable objects.
- The nozzle may be dragged on the metal surface, touching it lightly to the surface. **NOTE: The use of a drag cup with the PRO-CUT® is not recommended. The increased standoff distance reduces the overall performance of the PRO-CUT®.**

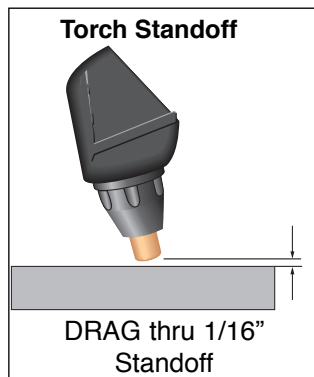

- Where possible, start the cut from the edge of the work piece.
- Keep moving! A steady speed is necessary. Do not pause.

Suggestions for Extra Utility from the PRO-CUT® System:

⚠ WARNING



ELECTRIC SHOCK CAN KILL.

- Turn off machine at the disconnect switch on the front of the machine before tightening, cleaning or replacing consumables.

1. Occasionally an oxide layer may form over the tip of the electrode, creating an insulating barrier between the electrode and nozzle. This will result in the tripping of the **PRO-CUT®**'s safety circuit. When this happens turn the power off, remove the nozzle and electrode and use the electrode to rub against the inside bottom surface of the nozzle. This will help remove any oxide buildup. Replace the nozzle, turn on the power and continue cutting. If the safety circuit continues to trip after cleaning the consumables, then replace them with a new set. Do not continue to try and cut with excessively worn consumables as this can cause damage to the torch head and will degrade cut quality. Do not allow torch cable or body to contact hot surface.
2. To improve consumable life, here are some suggestions that may be useful:
 - a. Make sure the air supply to the **PRO-CUT®** is clean and free of oil. Use several extra in line filters if necessary.
 - b. Minimize dross buildup on the nozzle tip by starting the cut from the edge of the plate when possible.
 - c. Pierce cutting should be done only when necessary. If piercing, angle torch about 30° from the plane perpendicular to the work piece, transfer the arc, then bring the torch perpendicular to the work and begin parallel movement.
 - d. Reduce the number of pilot arc starts without transferring to the work.
 - e. Reduce the pilot arc time before transferring to the work.
 - f. Set air pressure to recommended setting. A higher or lower pressure will cause turbulence in the plasma arc, eroding the orifice of the nozzle tip.
 - g. Use only Lincoln consumable parts. These parts are patented and using any other replacement consumables may cause damage to the torch or reduce cut quality.

PRO-CUT® 25



Return to Section TOC
Return to Master TOC

Return to Section TOC
Return to Master TOC

Return to Section TOC
Return to Master TOC

Return to Section TOC
Return to Master TOC



TABLE OF CONTENTS - ACCESSORIES -

Accessories	Section C
Options/Accessories	C-2

Return to Master TOC

Return to Master TOC

Return to Master TOC

Return to Master TOC

PRO-CUT® 25



ALWAYS USE GENUINE LINCOLN ELECTRIC ELECTRODES AND VORTECH™ NOZZLES

- Only Genuine Lincoln Electric consumables yield the best cutting performance for the **PRO-CUT® 25**.
- The patented VORTECH™ nozzle provides an extra “kick” of swirl as the arc exits the nozzle which improves cutting performance. No other nozzle has this capability or can match its performance.

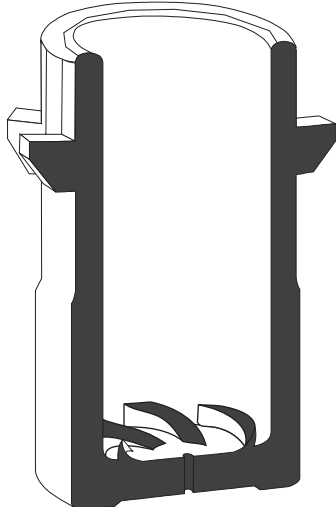

GENERAL OPTIONS / ACCESSORIES

The following options/accessories are available for your **PRO-CUT® 25** from your local Lincoln Distributor.

S22147-028 - VORTECH™ nozzle with an .028” (0.7 mm) Orifice

S22149 - Electrode - replacement electrodes for cutting.

S22150 - Shield Cup - This shields the nozzle and provides more visibility to the workpiece. Note the shield cup does not prevent the torch tip from touching the workpiece.

K1615 Series - PCT 20 Torches come in 15’ and 25’ lengths. Refer to the Parts Pages in the rear of this manual for Torch parts.

PRO-CUT® 25



TABLE OF CONTENTS -MAINTENANCE-

Maintenance	Section D
Routine Maintenance	D-2
Periodic Maintenance	D-2
Thermal Protection.....	D-2
Replacement Of Internal Fuse.....	D-2
Major Component Locations	D-3

Return to Master TOC

Return to Master TOC

Return to Master TOC

Return to Master TOC

PRO-CUT® 25



⚠ WARNING**ELECTRIC SHOCK** can kill.

- Have an electrician install and service this equipment.
- Turn the input power off at the fuse box before working on equipment.
- Do not touch electrically hot parts.
- Prior to performing preventative maintenance, perform the following **Capacitor Discharge Procedure** to avoid electric shock.

ROUTINE MAINTENANCE

1. Keep the cutting or gouging area and the area around the machine clean and free of combustible materials. No debris should be allowed to collect which could obstruct air flow to the machine.
2. Every 6 months or so, the machine should be cleaned with a low pressure airstream. Keeping the machine clean will result in cooler operation and higher reliability. Be sure to clean these areas:
 - Printed circuit boards and heat sinks
 - Power switch

⚠ CAUTION

- **When using a low pressure airstream, wear appropriate eye protection.**

3. Examine the sheet metal case for dents or breakage. Repair the case as required. Keep the case in good condition to insure that high voltage parts are protected and correct spacings are maintained. All external sheet metal screws must be in place to insure case strength and electrical ground continuity.
4. Inspect the cable periodically for any slits or puncture marks in the cable jacket. Replace if necessary. Check to make sure that nothing is crushing the cable and blocking the flow of air through the air tube inside. Also, check for kinks in the cable periodically and relieve any so as not to restrict the flow of air to the torch.

PERIODIC MAINTENANCE**⚠ WARNING****ELECTRIC SHOCK CAN KILL.**

- Turn off machine at the disconnect switch on the front of the machine before tightening, cleaning or replacing consumables.

Change consumables as required.

THERMAL PROTECTION

Thermal Detection Devices protect the machine from excessive operating temperatures. Excessive temperatures may be caused by a lack of cooling air or operating the machine beyond the duty cycle and output rating. If excessive operating temperatures should occur, the yellow thermal LED will light and the Detection Devices will prevent output voltage or current.

These Detection Devices are self-resetting once the machine cools sufficiently. If the thermostat shutdown was caused by excessive output or duty cycle and the fan is operating normally, the Power Switch may be left on and the reset should occur within a 15 minute period. If the fan is not turning or the air intake louvers were obstructed, then the power must be switched off and the fan problem or air obstruction must be corrected.

A protection circuit is included to monitor the voltage across filter capacitors. In the event that the capacitor voltage is too high, the protection circuit will prevent output.

REPLACEMENT OF INTERNAL FUSES

The **PRO-CUT® 25** has additional protection provided to some circuits through internal fuses. For replacement of those fuses proceed as follows:

1. Turn off the power to the unit and remove the input plug.
2. Allow the machine to stand for 5 minutes to let the input capacitors discharge.
3. Remove the machine cover.
4. Replace the blown fuse with a new 0.5A 500V slowblow fuse or 32A 400V fuse as appropriate.

NOTE: If the fuse blows again after power is restored, the cause could be an internal breakdown in the power unit. In this case, take the unit to an authorized Lincoln Field Service Shop.

PRO-CUT® 25



FIGURE D.2 – MAJOR COMPONENT LOCATIONS

- 1. Central Metal Wall
- 2. Main Board
- 3. Input Board
- 4. Control Board
- 5. Fan
- 6. Case Wraparound
- 7. Torch

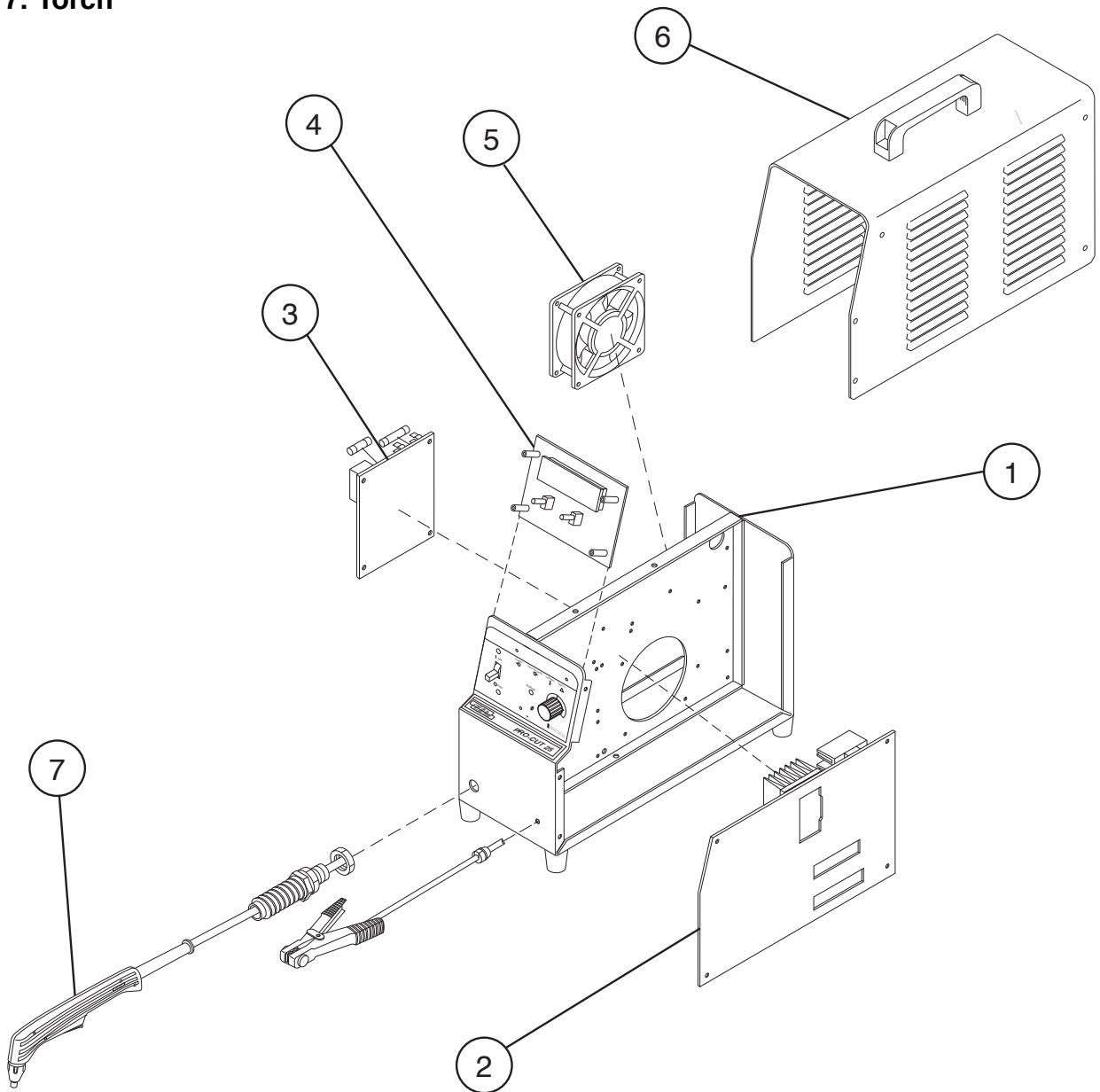

PRO-CUT® 25



Return to Section TOC

Return to Section TOC

Return to Section TOC

Return to Section TOC

Return to Master TOC

Return to Master TOC

Return to Master TOC

Return to Master TOC

NOTES

Return to Section TOC Return to Section TOC Return to Section TOC Return to Section TOC
Return to Master TOC Return to Master TOC Return to Master TOC Return to Master TOC

PRO-CUT® 25



TABLE OF CONTENTS -THEORY OF OPERATION SECTION-

Theory of Operation **Section E**

General Description E-2

Input Line Voltage and Auxiliary Transformer E-2

Precharge and Protection E-3

Main Transformer E-4

Output Section and Torch E-5

Control Board E-6

Protection Circuits E-7

 Overload Protection E-7

 Thermal Protection E-7

Accidental Operation Protection E-7

Safety Parts-In-Place Protection E-7

Insulated Gate Bipolar Transistor (IGBT) Operation E-8

FIGURE E.1 – PRO-CUT® 25 BLOCK LOGIC DIAGRAM

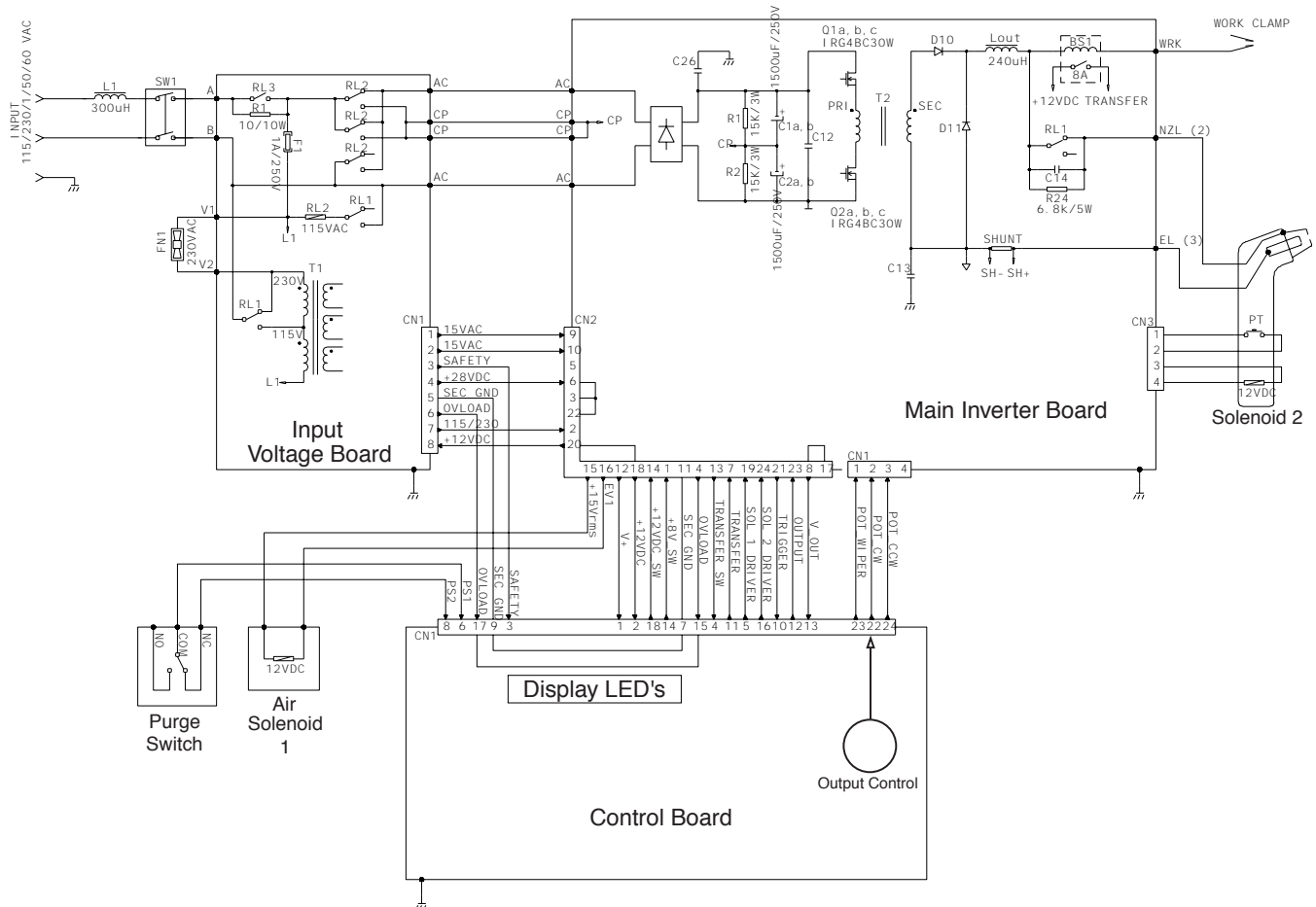

PRO-CUT® 25



Return to Master TOC

Return to Master TOC

Return to Master TOC

Return to Master TOC

FIGURE E.2 – INPUT LINE VOLTAGE

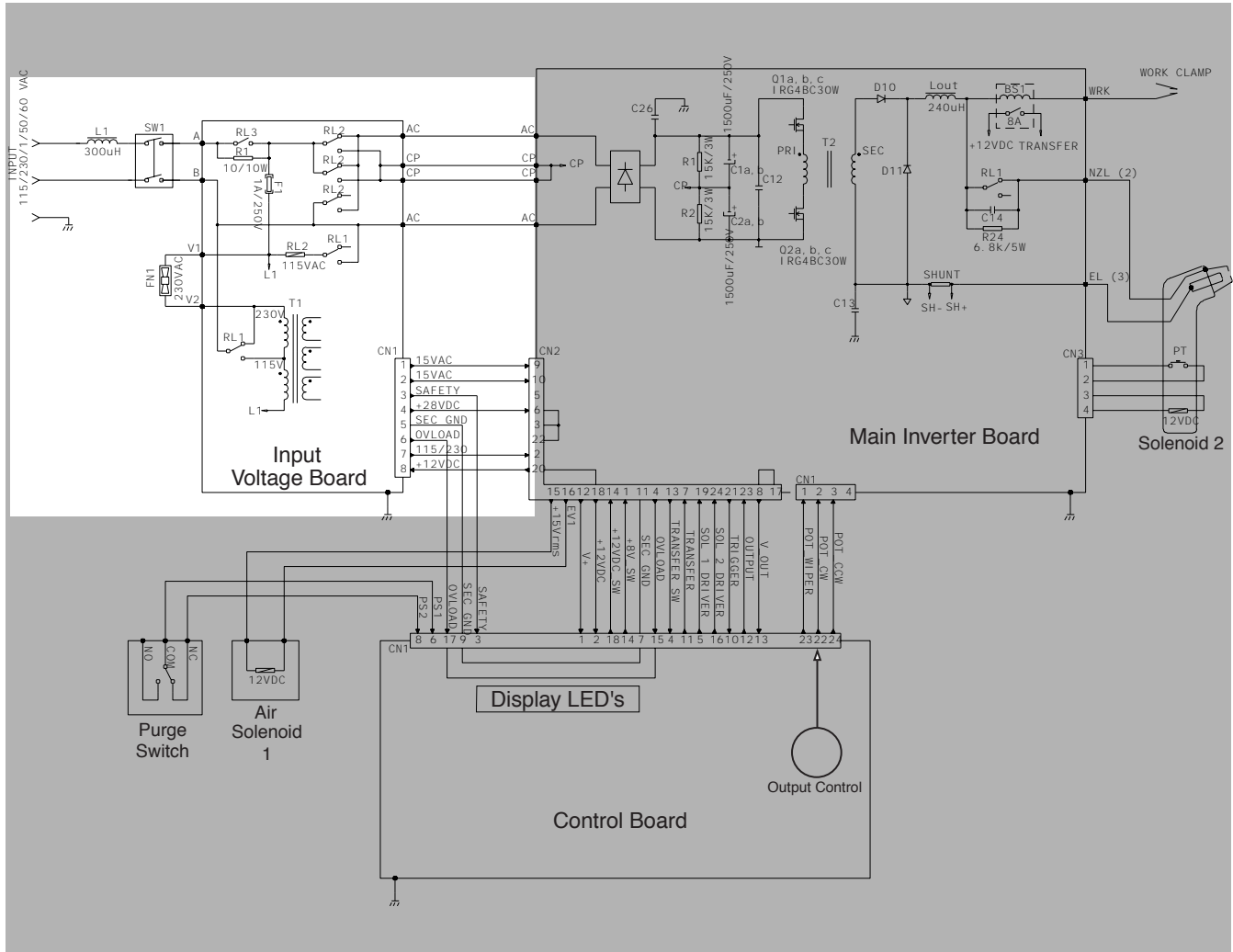

GENERAL DESCRIPTION

The **PRO-CUT® 25** is an inverter based constant current, continuous control plasma cutting power source. The control system has a safety mechanism to insure that the nozzle and electrode are in place before cutting or gouging. The **PRO-CUT® 25** initiates the plasma arc with a simple, yet reliable, touch start mechanism. This system eliminates many of the problems associated with hi-frequency type start systems.

INPUT LINE VOLTAGE, AND AUXILIARY TRANSFORMER

The single-phase input power of 115 230 Volts AC is connected to the machine, via an input cord, to a switch located on the front panel.

The **PRO-CUT® 25** Input voltage board automatically reconnects the auxiliary and inverter connections to configure the machine for either a low 115V AC or high 230V AC input voltage. The auxiliary transformer develops the appropriate AC voltages to operate the cooling fan, the control board, and the inverter board.

NOTE: Unshaded areas of Block Logic Diagram are the subject of discussion.

Return to Section TOC
 Return to Master TOC
 Return to Section TOC
 Return to Master TOC
 Return to Section TOC
 Return to Master TOC
 Return to Section TOC
 Return to Master TOC

FIGURE E.3 – PRECHARGE AND PROTECTION

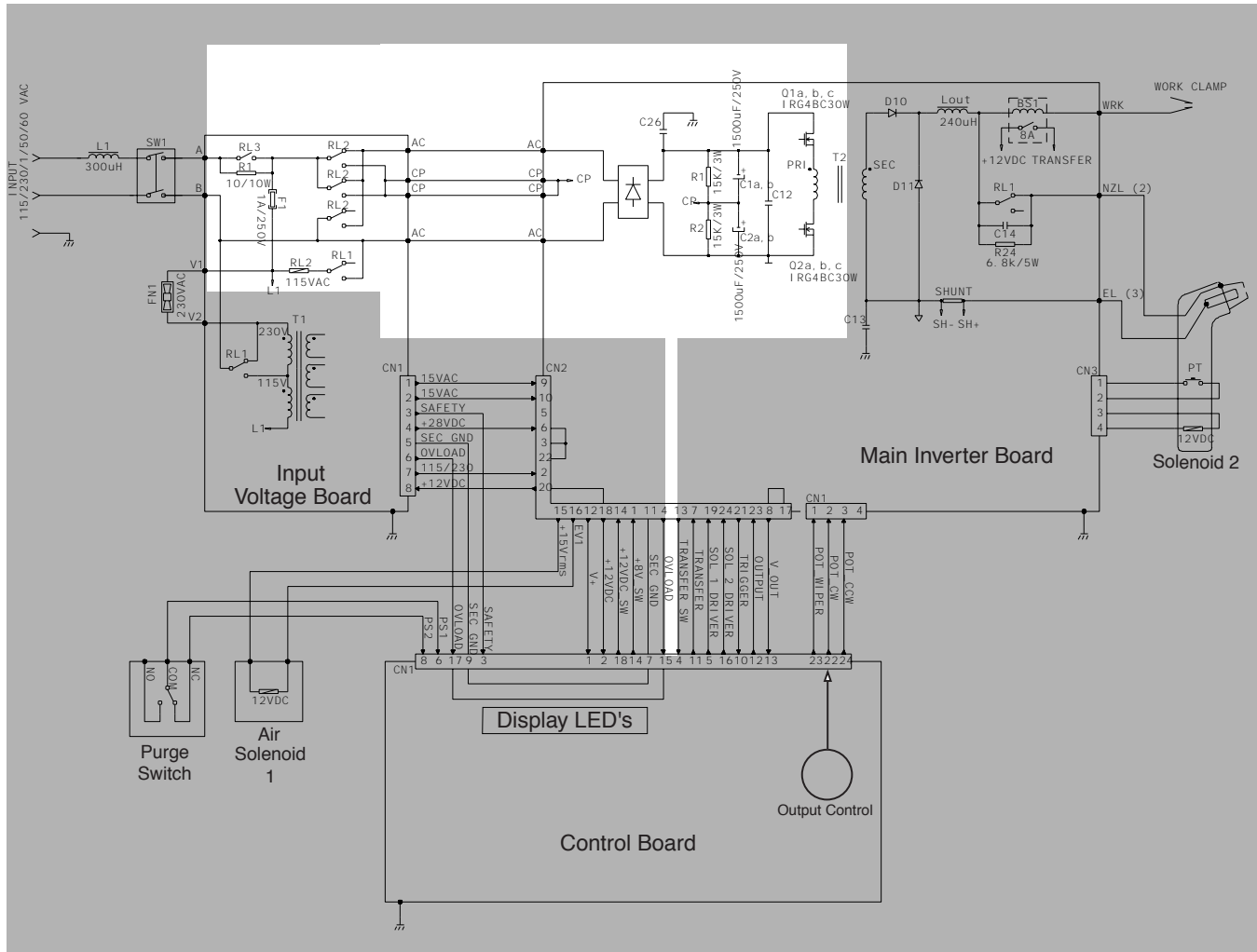

PRECHARGE AND PROTECTION

The input voltage is rectified by the input rectifier on the inverter board. The resultant DC voltage is applied to the filter capacitors through the automatic reconnect of the input board. The input board also contains precharging circuitry for the safe charging of the input filter capacitors. Once the capacitors are precharged the input board activates the RL3 input relay. This connects full input power to the filter capacitors. When the filter capacitors are fully charged they act as power supplies for the IGBT switching circuit. The IGBTs supply the main transformer primary winding with DC current flow.

The inverter board also monitors the filter capacitors for overvoltage. If this occurs, the appropriate signal is sent to the control board to disable the machines output and to turn on the Thermal/Voltage Overload status LED. See **IGBT Operation** discussion and diagrams in this section.

NOTE: Unshaded areas of Block Logic Diagram are the subject of discussion.

PRO-CUT® 25

LINCOLN
ELECTRIC

FIGURE E.4 – MAIN TRANSFORMER

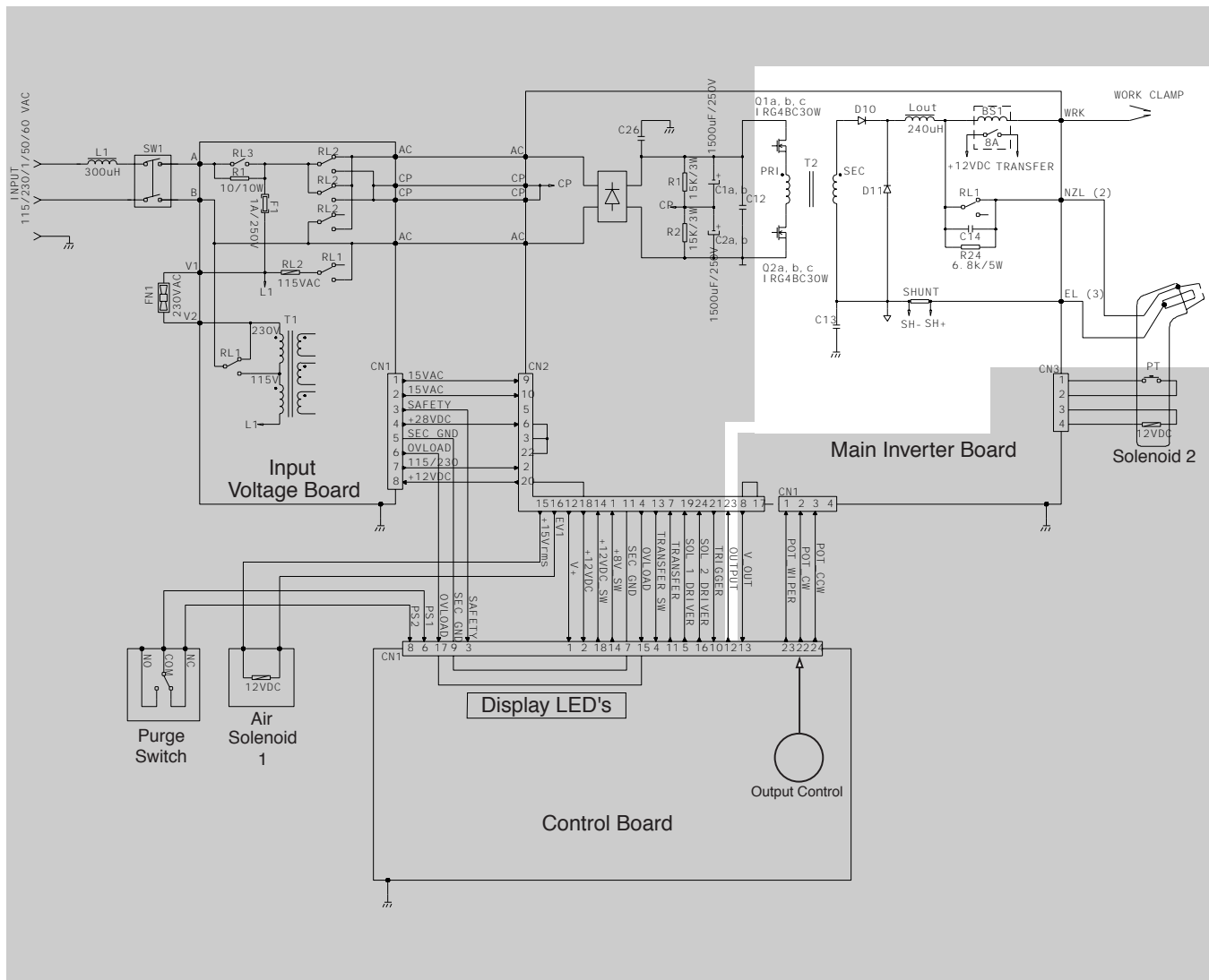

MAIN TRANSFORMER

The pair of IGBTs act as a switch assembly. This assembly feeds a primary winding of the main transformer. When current is pulsed through this primary winding, a resultant current is produced on the secondary winding of the main transformer. The DC current flow through the primary winding is redirected or “clamped” back to the filter capacitors when the IGBTs are turned off. This is needed due to the inductance of the transformer primary winding.

The primary current also passes through the current transformer, which sends a signal to the control circuits of the inverter board. This signal and the control circuits limit the maximum primary current flow through the IGBTs. The pair of IGBT's are fired at 15 microsecond intervals, creating a constant 66.6KHz output.

The secondary portion of the main transformer is made up of one winding. This winding supplies the electrode-to-nozzle and electrode-to-work voltages and the resulting currents. This high current winding is capable of supplying maximum output current during the cutting process. The output current is regulated via pulse width modulation. The control circuitry, on the inverter board, receives a signal from the control board and regulates the output current to the desired level.

PRO-CUT® 25

LINCOLN
ELECTRIC

FIGURE E.5 – PLASMA OUTPUT SECTION AND TORCH

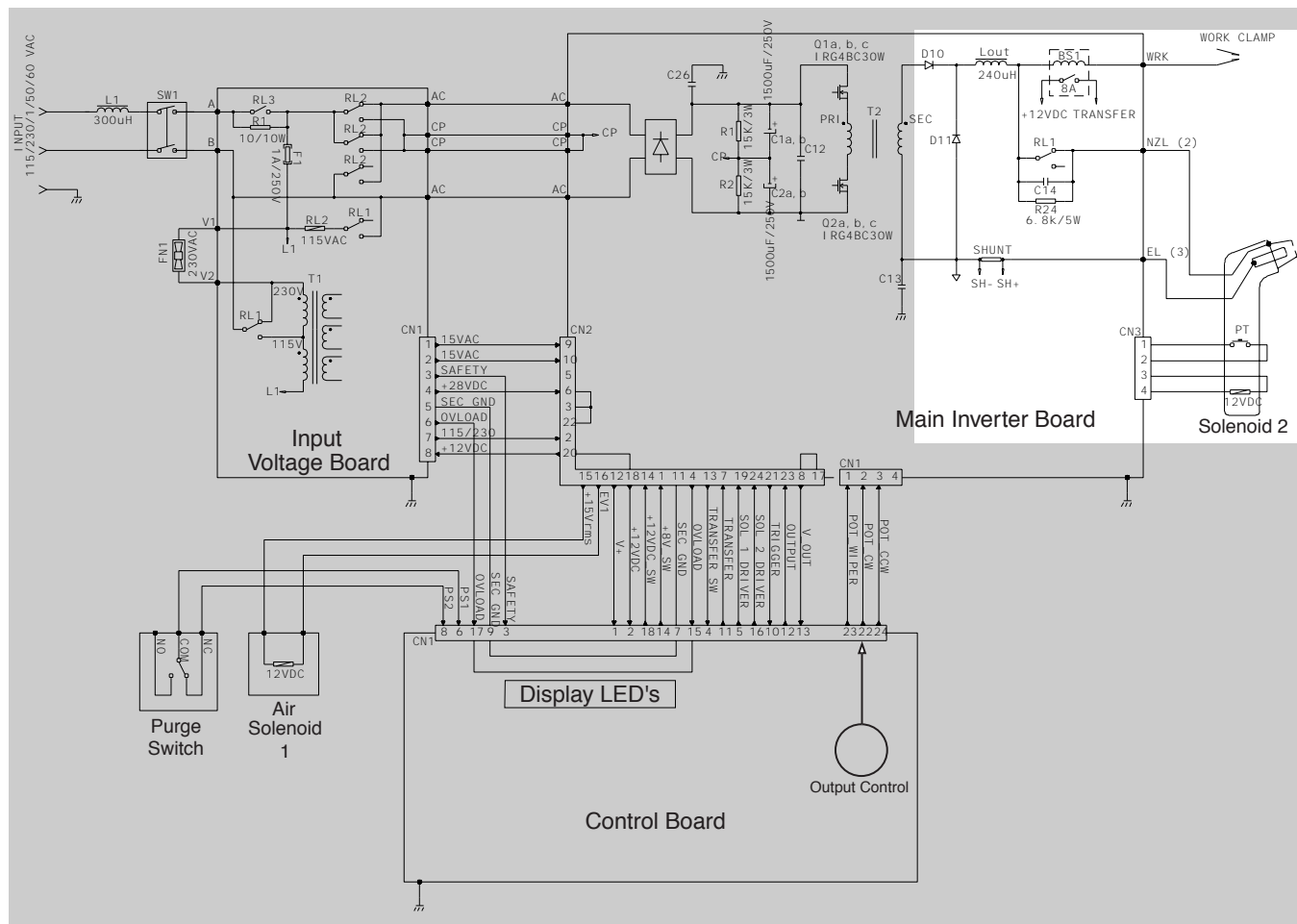

OUTPUT SECTION AND TORCH

The output section contains a relay which, upon receiving a pilot signal from the control board will enable the operation of a pilot arc or a cutting arc. The printed circuit board mounted current sensor regulates the pilot and cutting current. The output choke, which is in series with both the pilot circuit and the cutting circuit, provides current filtering to enhance arc stability.

The PCT 20 torch uses a patented touch start mechanism that provides superior starting performance over other touch start systems. The torch head consists of 3 major parts: torch body, insulator and piston. The insulator provides an electrical barrier between the piston and torch body. The piston provides a path for electrical current to the electrode. The piston also drives the electrode to the nozzle for arc initiation. The torch body contains the main torch components: the trigger, pilot arc, cutting arc, and air flow systems are included. See **Figure F.10 & G Section** for more detail.

A copper nozzle with a patented internal swirl is used to focus the arc. A small, precise hole in the end of the nozzle constricts the arc and increases the current density. As the air enters the torch head, it is directed

between the electrode and nozzle for maximum electrode cooling. A portion of the cooling air exits in the chamber through vents in the side of the nozzle. A swirl texture located inside the bottom of the nozzle increases the plenum air swirl strength, and improves arc start reliability and parts-in-place verification.

Plasma arc initiation occurs as follows: First, in the idle state, a spring inside the torch head pushes the piston and electrode forward to make continuity with the nozzle. When the trigger is pulled, air flow begins and creates enough back force on the electrode to overcome the force of the spring. However, the solenoid valve allows enough forward force on the piston to maintain continuity between the consumables. After this continuity has been verified, output current is established and regulated. Once the current stabilizes, the solenoid valve turns off, removing the forward force on the piston. The back pressure drives the piston and electrode away from the nozzle, creating the plasma arc. The air stream forces the arc out the orifice of the nozzle. This appears as a pilot arc, which can then be transferred for cutting.

FIGURE E.6 – CONTROL BOARD

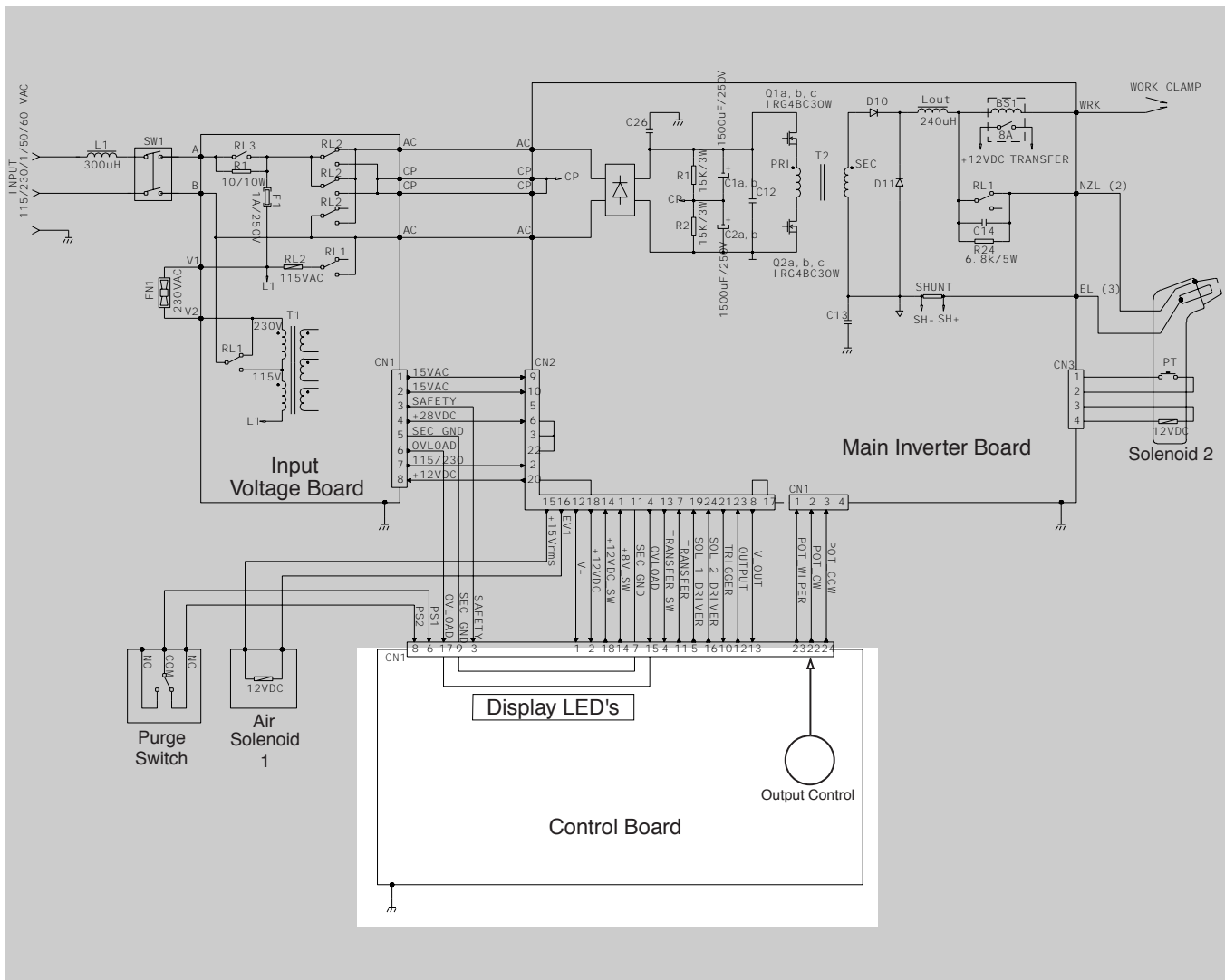

CONTROL BOARD

The control board receives status and analog feedback signals from the inverter board, input board, and various sensors. The control circuitry interprets these signals, makes decisions and changes the machines mode and output to satisfy the requirements as defined by the circuitry. The control board sends a signal to the inverter board to control the output current but the actual regulation circuits are on the inverter board.

The display board, directly connected to the control board, communicates **PRO-CUT® 25** status and operating conditions to the user. There are four status indicators: Power On, Gas Pressure, Thermal Overload, and Safety Error.

PRO-CUT® 25



PROTECTION CIRCUITS

Protection circuits are designed into the **PRO-CUT**® 25 machine to sense trouble, damages, problems with internal components, and to provide safety. These are the main protection circuits:

OVERLOAD PROTECTION

The **PRO-CUT**® 25 is electrically protected from producing higher than normal output currents. If the output current exceeds 25-30 amps, an electronic protection circuit limits the current to within the capabilities of the machine. A second circuit monitors the input voltage and the voltage across the input filter capacitors. If the input voltage or filter capacitor voltage is too high, or too low, the protection circuit will prevent machine output.

THERMAL PROTECTION

Three thermal protection devices protect the machine from excessive operating temperatures. One device is located on the output choke, one is located inside the main transformer, and another is mounted on one of the IGBT heat sinks. Excessive temperatures may be caused by a lack of cooling air or by operating the machine beyond the duty cycle and output rating. If excessive operating temperatures should occur, the thermal status indicator will turn on and the thermostat will prevent output voltage or current. The thermal protection devices are self-resetting once the machine cools sufficiently. If the shutdown was caused by excessive output or duty cycle and the fans are operating normally, the power switch may be left on and the reset should occur within a 15 minute period. If the fan is not turning or the air intake louvers are obstructed, the input power must be removed and the fan problem or air obstruction must be corrected. After a thermal overload occurs and the machine resets, it may be necessary to activate the torch trigger twice before a pilot arc will be initiated. This is a safety precaution, to eliminate accidental pilot arc initiation when the thermal protection self resets.

ACCIDENTAL OPERATION PROTECTION

The **PRO-CUT**® 25 has two protection circuits to eliminate accidental pilot arc initiation. These two circuits operate when the machine is first turned on and after a thermal overload occurs. In these cases, the first time the torch trigger is activated nothing will happen. The torch trigger must be activated a second time before pilot arc initiation occurs. This protection is added in case the machine is turned on and the trigger is already activated or if a thermal overload self resets and the trigger is activated.

SAFETY PARTS-IN-PLACE PROTECTION

The **PRO-CUT**® 25 has protection circuits to detect the proper connection of the torch and the proper installation of the consumables. If an error is detected with either of these two items, the Safety status LED will be turned on and the output of the machine will be disabled. The **PRO-CUT**® 25 must be turned off and the problem must be corrected before normal operation can occur.

PRO-CUT® 25



Return to Section TOC
Return to Master TOC
Return to Section TOC
Return to Master TOC
Return to Section TOC
Return to Master TOC
Return to Section TOC
Return to Master TOC

INSULATED GATE BIPOLAR TRANSISTOR (IGBT) OPERATION

An IGBT is a type of transistor. IGBTs are semiconductors well suited for high frequency switching and high current applications.

Drawing A shows an IGBT in a passive mode. There is no gate signal, zero volts relative to the source, and therefore, no current flow. The drain terminal of the IGBT may be connected to a voltage supply; but since there is no conduction the circuit will not supply current to components connected to the source. The circuit is turned off like a light switch in the OFF position.

Drawing B shows the IGBT in an active mode. When the gate signal, a positive DC voltage relative to the source, is applied to the gate terminal of the IGBT, it is capable of conducting current. A voltage supply connected to the drain terminal will allow the IGBT to conduct and supply current to circuit components coupled to the source. Current will flow through the conducting IGBT to downstream components as long as the positive gate signal is present. This is similar to turning ON a light switch.

FIGURE E.5 – IGBT

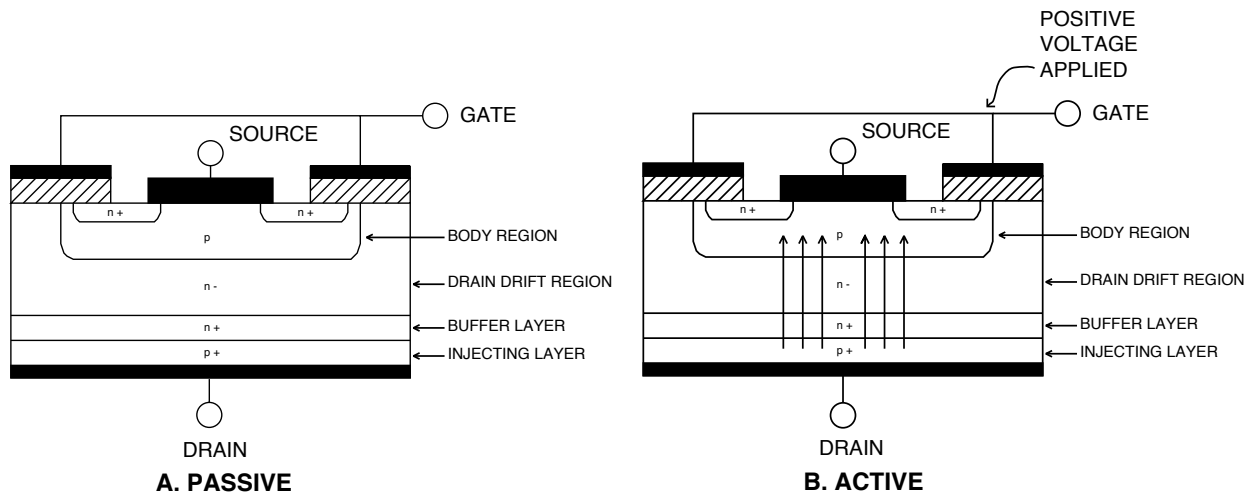

TABLE OF CONTENTS

TROUBLESHOOTING & REPAIR SECTION

Troubleshooting & Repair Section

Section F

How to Use Troubleshooting GuideF-2

PC Board Troubleshooting Procedures and ReplacementF-3

Troubleshooting GuideF-4

Test Procedures

- Input Filter Capacitor Discharge ProcedureF-9
- Main Inverter Board Resistance TestF-11
- Input Board Voltage TestF-17
- Main Inverter Board Voltage TestF-21
- Torch Continuity and Solenoid TestF-25
- Air/Gas Solenoid TestF-29

Replacement Procedures

- Control Board Removal and ReplacementF-31
- Input Board Removal and ReplacementF-35
- Main Inverter Board Removal and ReplacementF-39
- Switch Removal and ReplacementF-43
- Fan Removal and ReplacementF-45
- Retest after RepairF-48

Return to Master TOC

Return to Master TOC

Return to Master TOC

Return to Master TOC

HOW TO USE TROUBLESHOOTING GUIDE



CAUTION

Service and repair should be performed by only Lincoln Electric Factory Trained Personnel. Unauthorized repairs performed on this equipment may result in danger to the technician and machine operator and will invalidate your factory warranty. For your safety and to avoid Electrical Shock, please observe all safety notes and precautions detailed throughout this manual.

This Troubleshooting Guide is provided to help you locate and repair possible machine malfunctions. Simply follow the three-step procedure listed below.

Step 1. LOCATE PROBLEM (SYMPTOM). Look under the column labeled “PROBLEM (SYMPTOMS)”. This column describes possible symptoms that the machine may exhibit. Find the listing that best describes the symptom that the machine is exhibiting. Symptoms are grouped into three main categories: Output Problems, Function Problems, and LED Function Problems.

Step 2. PERFORM EXTERNAL TESTS. The second column, labeled “POSSIBLE AREAS OF MISADJUSTMENT(S)”, lists the obvious external possibilities that may contribute to the machine symptom. Perform these tests/checks in the order listed. In general, these tests can be conducted without removing the case wrap-around cover.

Step 3. PERFORM COMPONENT TESTS. The last column, labeled “Recommended Course of Action” lists the most likely components that may have failed in your machine. It also specifies the appropriate test procedure to verify that the subject component is either good or bad. If there are a number of possible components, check the components in the order listed to eliminate one possibility at a time until you locate the cause of your problem.

All of the referenced test procedures referred to in the Troubleshooting Guide are described in detail at the end of this chapter. Refer to the Troubleshooting and Repair Table of Contents to locate each specific Test Procedure. All of the referred to test points, components, terminal strips, etc., can be found on the referenced electrical wiring diagrams and schematics. Refer to the Electrical Diagrams Section Table of Contents to locate the appropriate diagram.



CAUTION

If for any reason you do not understand the test procedures or are unable to perform the test/repairs safely, contact the Lincoln Electric Service Department for electrical troubleshooting assistance before you proceed. Call 1-888-935-3877

PRO-CUT® 25



PC BOARD TROUBLESHOOTING PROCEDURES

**WARNING****ELECTRIC SHOCK can kill.**

Have an electrician install and service this equipment. Turn the machine OFF before working on equipment. Do not touch electrically hot parts.

Sometimes machine failures appear to be due to PC board failures. These problems can sometimes be traced to poor electrical connections. To avoid problems when troubleshooting and replacing PC boards, please use the following procedure:

1. Determine to the best of your technical ability that the PC board is the most likely component causing the failure symptom.
2. Check for loose connections at the PC board to assure that the PC board is properly connected.
3. If the problem persists, replace the suspect PC board using standard practices to avoid static electrical damage and electrical shock. Read the warning inside the static resistant bag and perform the following procedures:



ATTENTION
Static-Sensitive
Devices
Handle only at
Static-Safe
Workstations

Reusable
Container
Do Not Destroy

PC Board can be damaged by static electricity.

- Remove your body's static charge before opening the static-shielding bag. Wear an anti-static wrist strap. For safety, use a 1 Meg ohm resistive cord connected to a grounded part of the equipment frame.
- If you don't have a wrist strap, touch an unpainted, grounded, part of the equipment frame. Keep touching the frame to prevent static build-up. Be sure not to touch any electrically live parts at the same time.
- Tools which come in contact with the PC Board must be either conductive, anti-static or static-dissipative.

- Remove the PC Board from the static-shielding bag and place it directly into the equipment. Don't set the PC Board on or near paper, plastic or cloth which could have a static charge. If the PC Board can't be installed immediately, put it back in the static-shielding bag.
 - If the PC Board uses protective shorting jumpers, don't remove them until installation is complete.
 - If you return a PC Board to The Lincoln Electric Company for credit, it must be in the static-shielding bag. This will prevent further damage and allow proper failure analysis.
4. Test the machine to determine if the failure symptom has been corrected by the replacement PC board.

NOTE: Allow the machine to heat up so that all electrical components can reach their operating temperature.

5. Remove the replacement PC board and substitute it with the original PC board to recreate the original problem.
 - a. If the original problem does not reappear by substituting the original board, then the PC board was not the problem. Continue to look for bad connections in the control wiring harness, junction blocks, and terminal strips.
 - b. If the original problem is recreated by the substitution of the original board, then the PC board was the problem. Reinstall the replacement PC board and test the machine.
6. Always indicate that this procedure was followed when warranty reports are to be submitted.

NOTE: Following this procedure and writing on the warranty report, "INSTALLED AND SWITCHED PC BOARDS TO VERIFY PROBLEM," will help avoid denial of legitimate PC board warranty claims.

PRO-CUT® 25

Observe Safety Guidelines detailed in the beginning of this manual.

TROUBLESHOOTING GUIDE

PROBLEMS (SYMPTOMS)	POSSIBLE AREAS OF MISADJUSTMENT(S)	RECOMMENDED COURSE OF ACTION
OUTPUT PROBLEMS		
Major physical or electrical damage is evident when the sheet metal cover(s) are removed.	1. Contact your local authorized Lincoln Electric Field Service Facility for technical assistance.	1. Contact the Lincoln Electric Service Department, 1-888-935-3877
Machine is dead – no output – no fan – no status indicator lights.	1. Make sure that the input power switch is in the “ON” position. 2. Check the input voltage at the machine. Input voltage must match the rating plate. 3. Check for blown or missing fuses in the input lines and the 1A slow blow fuse on the input board.	1. Check the input power switch for proper operation. 2. Check the leads associated with the power switch for loose or faulty connections. See the Wiring Diagram. 3. Check all connectors and wires for loose or faulty connections. 4. Perform the <i>Input Voltage Board Test</i> .
Machine is malfunctioning - no output - no status indicator lights - fans run.	1. Check the input voltage at the machine. Input voltage must match the rating plate.	1. Check all connectors and wires for loose or faulty connections. See Wiring Diagram. 2. Perform the <i>Input Voltage Board Test</i> . 3. The control board may be faulty. Replace.

 **CAUTION**

If for any reason you do not understand the test procedures or are unable to perform the test/repairs safely, contact the Lincoln Electric Service Department for electrical troubleshooting assistance before you proceed. Call 1-888-935-3877.

Return to Section TOC

Return to Master TOC

TROUBLESHOOTING GUIDE

Observe Safety Guidelines detailed in the beginning of this manual.

PROBLEMS (SYMPTOMS)	POSSIBLE AREAS OF MISADJUSTMENT(S)	RECOMMENDED COURSE OF ACTION
FUNCTION PROBLEMS		
The machine powers up properly, but there is no response (no air flow or pilot arc) when the torch trigger is pulled. Only the power LED is lit.	<ol style="list-style-type: none"> 1. Make sure the torch handle or cable is not damaged or pulled from the machine. Replace if necessary. 2. Make sure the air supply is converted and operating properly. 	<ol style="list-style-type: none"> 1. Check all connectors and wires for loose or faulty connections. See Wiring Diagram. 2. Perform the Air/Gas Solenoid Test. 3. The control board may be faulty. Replace.
The machine powers up properly, but only air flows when the torch trigger is pulled; no pilot arc is established.	<ol style="list-style-type: none"> 1. Make sure the torch consumables are in place and in good condition. Replace if necessary. 2. Set air pressure at 65psi. 3. Make sure there are no kinks or restrictions for air flow in the torch cable. 4. Make sure that the correct size nozzle is being used. Must be a .028 orifice. PRO-CUT[®] 55 size nozzles will not work with the PRO-CUT[®] 25 system. 	<ol style="list-style-type: none"> 1. Check all connectors and wires for loose or faulty connections. See Wiring Diagram. 2. Perform the Torch Continuity and Solenoid Test. 3. Perform the Main Inverter Board Voltage and Resistance Tests. 4. The control board may be faulty. Replace.
The machine powers up properly, and cuts OK with 230 input applied. With 115 applied the pilot arc ignites but goes out when cutting commences. Or, no pilot or cutting when 115 input is supplied.	<ol style="list-style-type: none"> 1. CP leads to its terminal from the input to the inverter board are loose or disconnected. 	<ol style="list-style-type: none"> 1. Reconnect the leads to its correct terminal per the Wiring Diagram. 2. Perform the Input Board Test. 3. The input board may be faulty. Replace.
The air begins to flow when the torch trigger is pulled. There is a very brief pilot arc. (Normal is 3 Seconds.) The sequence is repeated with subsequent trigger pulls.	<ol style="list-style-type: none"> 1. Check the input voltage at the machine. Input voltage must match the rating plate. 2. Make sure the torch consumable parts are in place and in good condition. Replace if necessary. 3. Make sure there are no kinks or restrictions for air flow in the torch cable. 4. Make sure the air pressure is set at 65psi. 5. Make sure that the correct size nozzle is being used. Must be a .028 orifice. PRO-CUT[®] 55 size nozzles will not work with the PC 25 system. 	<ol style="list-style-type: none"> 1. Check all connectors and wires for loose or faulty connections. See Wiring Diagram. 2. Perform the Main Inverter Board Voltage and Resistance Tests. 3. The control board may be faulty. Replace.

Observe Safety Guidelines detailed in the beginning of this manual.

TROUBLESHOOTING GUIDE

PROBLEMS (SYMPTOMS)	POSSIBLE AREAS OF MISADJUSTMENT(S)	RECOMMENDED COURSE OF ACTION
FUNCTION PROBLEMS		
The cutting arc starts but sputters badly.	<ol style="list-style-type: none"> 1. Make sure the operating procedure is correct for the process. See the Operation section of the manual. 2. Make sure the work clamp is connected tightly to the work piece. 3. Make sure the torch consumable parts are in place and in good condition. Replace if necessary. 4. Make sure the air pressure is set at 65psi. 5. Make sure the air supply is not contaminated with oil or excessive water. 	<ol style="list-style-type: none"> 1. Check all connectors and wires for loose or faulty connections. See Wiring Diagram. 2. Perform the Torch Continuity and Solenoid Test. 3. Perform the Main Inverter Board Voltage and Resistance Tests. 4. The control board may be faulty. Replace. 5. Use the correct extension cord. See the instruction manual.
The pilot arc is normal, but the arc will not transfer to the work piece.	<ol style="list-style-type: none"> 1. Make sure the operating procedure is correct for the process. See the Operation section of the manual. 2. Make sure the work clamp is connected tightly to the work piece. 3. The work piece must be electrically conductive material, and the work clamp must make a good electrical connection with the work piece. 4. Do not use a drag cup. Not recommended for PRO-CUT® 25 use. 	<ol style="list-style-type: none"> 1. Check all connectors and wires for loose or faulty connections. See Wiring Diagram. 2. Perform the Main Inverter Board Voltage and Resistance Tests. 3. The control board may be faulty. Replace.
Trigger or purge is activated brief air flow then the safety light illuminates.		<ol style="list-style-type: none"> 1. The Control Board is defective. Replace.
Poor performance of pilot arc or cutting. Poor consumable life.	<ol style="list-style-type: none"> 1. Check pressure switch to be functioning correctly (opening/closing) at its correct pressure. 2. Check pressure gauge to be correct in its reading. 3. Check for recommended flow rate coming from the torch end with a flow meter. 	<ol style="list-style-type: none"> 1. Try increasing or decreasing the air pressure to see if conditions improve. 2. Replace regulator or pressure switch may be required. 3. Screen in air line at inlet to air solenoid may be clogged. Clean. (no screen before 7/1/02) 4. Ensure that air is clean and dry. External filters may be used.

PRO-CUT® 25



Observe Safety Guidelines detailed in the beginning of this manual.

TROUBLESHOOTING GUIDE

PROBLEMS (SYMPTOMS)	POSSIBLE AREAS OF MISADJUSTMENT(S)	RECOMMENDED COURSE OF ACTION
FUNCTION PROBLEMS		
<p>Will only cut thin gauge material or cutting is 1/2 of what it should be. Cuts for 3 seconds then quits.</p>	<p>The ground lead or clamp is disconnected. Unit is not transferring to cut mode.</p>	<ol style="list-style-type: none"> 1. Replace or repair, clamp or cable. 2. Clamp directly to the piece to be cut. 3. Look for the transfer signal from the inverter board to the control Board per the enhanced diagram. 4. Possible replacement of the inverter board per the signal of the enhanced diagram. 5. Possible replacement of the Control Board per the signal of the enhanced diagram. 6. Use the correct extension cord. See the instruction manual.
<p>When nothing is described for your problem, or you have performed your test with no solution.</p>		<ol style="list-style-type: none"> 1. Unplug and re-plug in all the printed circuit board harness connectors.

 **CAUTION**

If for any reason you do not understand the test procedures or are unable to perform the test/repairs safely, contact the Lincoln Electric Service Department for electrical troubleshooting assistance before you proceed. Call 1-888-935-3877.

PRO-CUT® 25



Return to Section TOC
Return to Master TOC

Observe Safety Guidelines detailed in the beginning of this manual.

TROUBLESHOOTING GUIDE

PROBLEMS (SYMPTOMS)	POSSIBLE AREAS OF MISADJUSTMENT(S)	RECOMMENDED COURSE OF ACTION
LED FUNCTION PROBLEMS		
<p>The Thermal LED is lit after normal use.</p>	<ol style="list-style-type: none"> 1. One of the machine's thermal protection circuits has tripped. Do not turn the PRO-CUT® 25 off. Allow the machine to cool. The thermal protection circuits will reset themselves. 2. Either the duty cycle has been exceeded, the fan is not functioning, or the louvers are blocked. 3. Thermo light comes on when over voltage occurs +/-10% must be with in 10%. 	<ol style="list-style-type: none"> 1. Check all connectors and wires for loose or faulty connections. See Wiring Diagram. 2. The inverter board may be faulty. Replace. 3. The control board may be faulty. Replace. 4. Use the correct extension cord. See the instruction manual.

 **CAUTION**

If for any reason you do not understand the test procedures or are unable to perform the test/repairs safely, contact the Lincoln Electric Service Department for electrical troubleshooting assistance before you proceed. Call 1-888-935-3877.

PRO-CUT® 25



Return to Section TOC
Return to Master TOC

INPUT FILTER CAPACITOR DISCHARGE PROCEDURE



WARNING

Service and repair should be performed by only Lincoln Electric factory trained personnel. Unauthorized repairs performed on this equipment may result in danger to the technician or machine operator and will invalidate your factory warranty. For your safety and to avoid electrical shock, please observe all safety notes and precautions detailed throughout this manual.

If for any reason you do not understand the test procedures or are unable to perform the test/repairs safely, contact the Lincoln Electric Service Department for electrical troubleshooting assistance before you proceed. Call 1-888-935-3877.

DESCRIPTION

This procedure will drain off any charge stored in the four Capacitors that are part of the Inverter Board Assembly. This procedure MUST be performed, as a safety precaution, before conducting any test or repair procedure that requires you to touch internal components of the machine.

MATERIALS NEEDED

- 4mm Allen Wrench
- Volt/Ohmmeter
- 7mm Nut Driver
- Crescent Wrench
- Insulated Gloves
- Insulated Pliers
- High Wattage Resistor - 25 to 1000 ohms, 25 watts minimum

INPUT FILTER CAPACITOR DISCHARGE PROCEDURE *(continued)*

⚠ WARNING

ELECTRIC SHOCK can kill.



- Have an electrician install and service this equipment.
 - Turn the input power off at the fuse box before working on equipment.
 - Do not touch electrically hot parts.
- Prior to performing preventative maintenance, perform the following capacitor discharge procedure to avoid electric shock.

5. Be careful not to make contact with the capacitor terminals located at the top of the main inverter Board.
6. Obtain a high resistance and high wattage resistor (25-1000 ohms and 25 watts minimum). This resistor is not supplied with machine. NEVER USE A SHORTING STRAP FOR THIS PROCEDURE.
7. Locate the eight capacitor terminals located at the top rear of the main inverter board. See Figure F.1
8. Use electrically insulated gloves and insulated pliers. Hold the body of the resistor and connect the resistor leads across the two capacitor terminals. Hold the resistor in place for 10 seconds. DO NOT TOUCH CAPACITOR TERMINALS WITH YOUR BARE HANDS.
9. Repeat the discharge procedure for the other capacitors.
10. Check the voltage across the terminals of all capacitors with a DC voltmeter. Voltage should be zero. If any voltage remains, repeat this capacitor discharge procedure.

DISCHARGE PROCEDURE

1. Remove input power to the PRO-CUT® 25 machine.
2. Remove carrying handle using a 4mm allen wrench.
3. Using a crescent wrench, carefully remove the plastic nut from around the pressure regulator located on the top of the machine.
4. Using a 7mm nut driver, remove the case wraparound.

FIGURE F.1 – LOCATION OF INPUT FILTER CAPACITOR TERMINALS

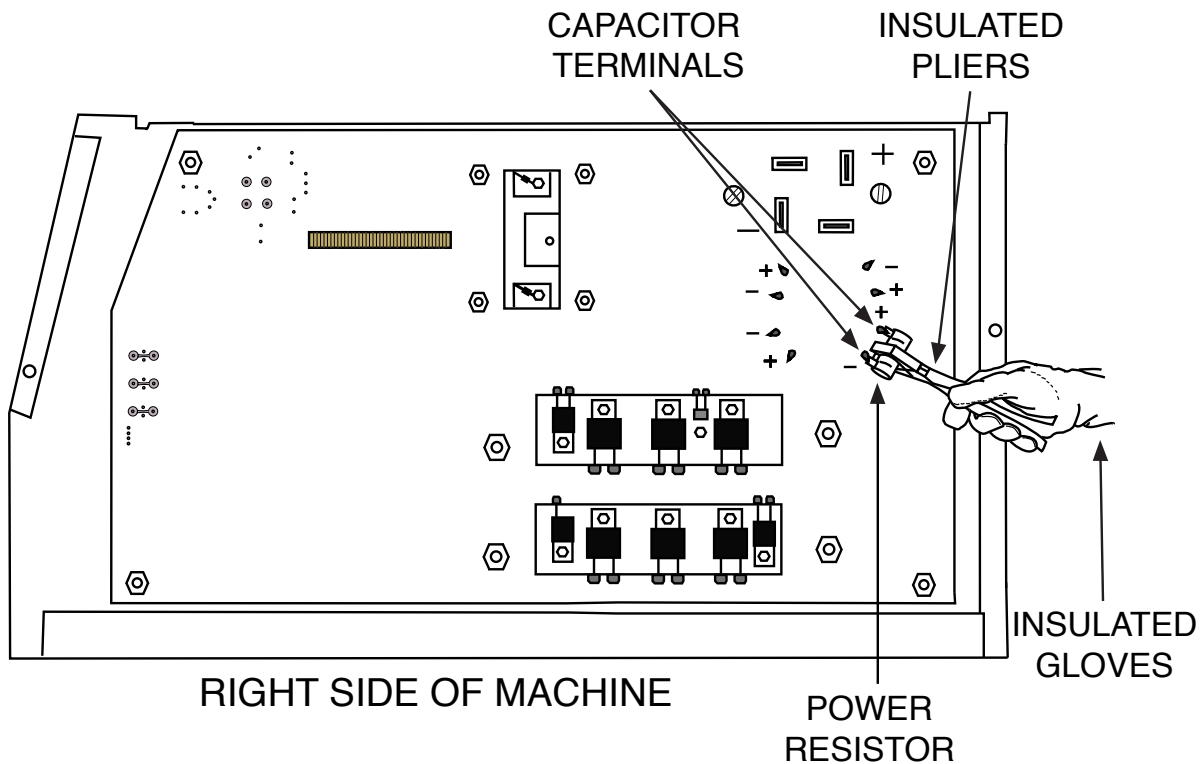

PRO-CUT® 25



Return to Section TOC

Return to Master TOC

MAIN INVERTER BOARD RESISTANCE TEST



WARNING

Service and repair should be performed by only Lincoln Electric factory trained personnel. Unauthorized repairs performed on this equipment may result in danger to the technician or machine operator and will invalidate your factory warranty. For your safety and to avoid electrical shock, please observe all safety notes and precautions detailed throughout this manual.

If for any reason you do not understand the test procedures or are unable to perform the test/repairs safely, contact the Lincoln Electric Service Department for electrical troubleshooting assistance before you proceed. Call 1-888-935-3877.

DESCRIPTION

This test will determine if the Main Inverter Board has any “shorted” or “leaky” power diodes or Insulated Gate Bipolar Transistors IGBT’s. Also it will indicate if P1 is “shorted” or “open”.

MATERIALS NEEDED

- Analog Volt/Ohmmeter
- Wiring Diagram
- 7mm Nut Driver
- 4mm Allen Wrench
- Crescent Wrench

MAIN INVERTER BOARD RESISTANCE TEST *(continued)*

FIGURE F.2

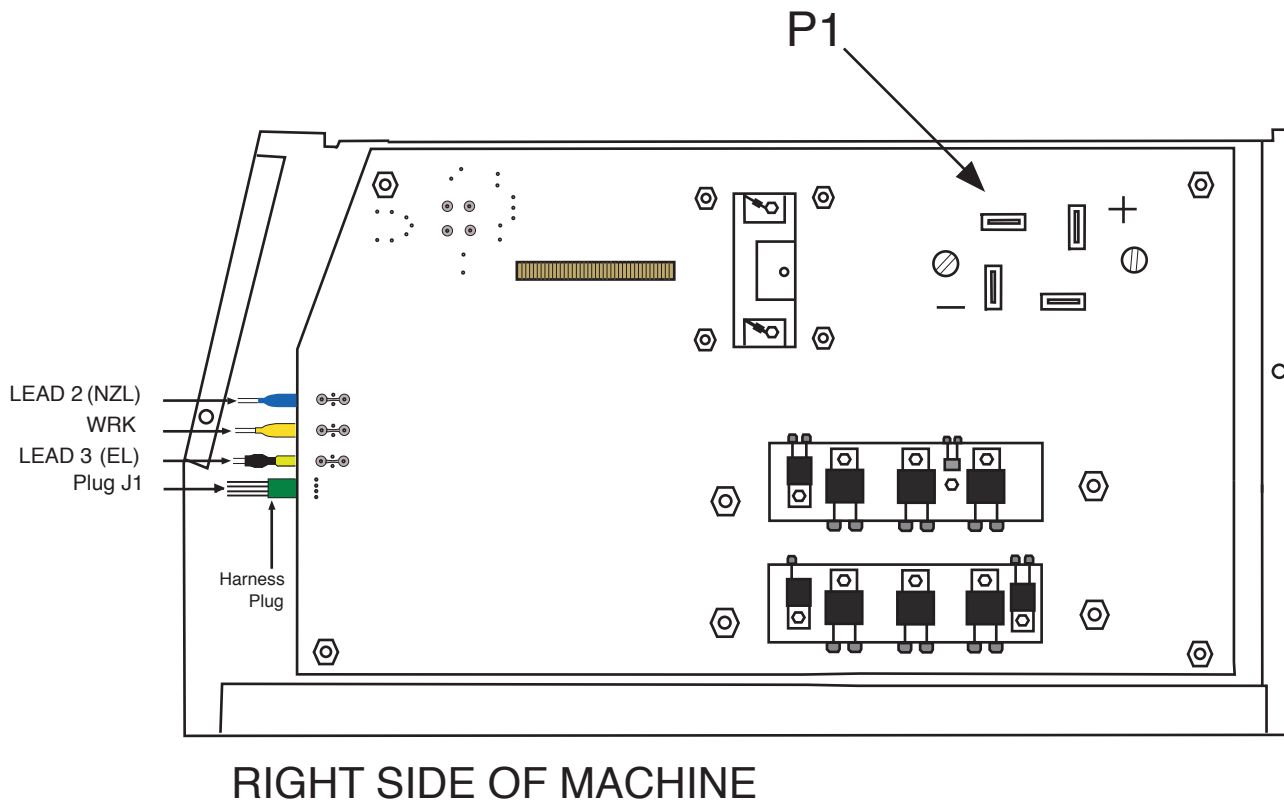

TEST PROCEDURE

1. Remove main input power to the **PRO-CUT® 25**.
2. Remove carrying handle using a 4mm allen wrench.
3. Using a crescent wrench, carefully remove the plastic nut from around the pressure regulator located on the top of the machine.
4. Using a 7mm nut driver, remove the case wraparound.
5. Perform the **Input Filter Capacitor Discharge Procedure** detailed earlier in this section.
6. Visually check for burned or damaged components. If any components are physically damaged or determined to be faulty, the Main Inverter Board should be replaced.
7. Check the input rectifier bridge (P1) for shorts or opens. See Figure F.2

PRO-CUT® 25



MAIN INVERTER BOARD RESISTANCE TEST *(continued)*

8. Check the IGBTs for “shorts”. Check each IGBT (6) from Gate to Collector. Normal resistance is approximately 100 ohms.

Also check each device from Gate to Emitter. Normal resistance is approximately 40 ohms.

Check each device from Emitter to Collector. Normal reading is high resistance in one polarity and a low resistance in the opposite polarity.

NOTE: These devices will usually fail “short”, resulting in a zero or very low resistance reading. If they “open” physical damage should be evident.

FIGURE F.3 LOCATION OF IGBTs (6)

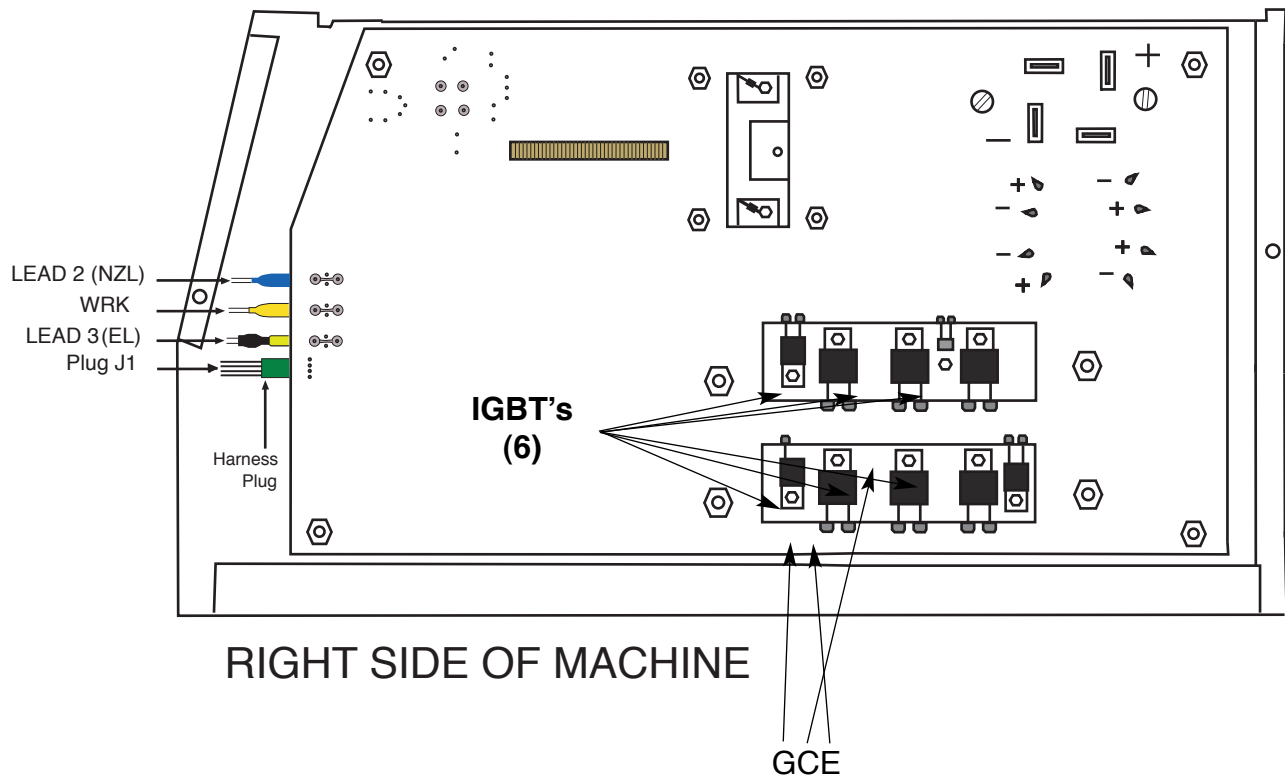

Return to Section TOC
Return to Master TOC

MAIN INVERTER BOARD RESISTANCE TEST (continued)

- 9. Check Diodes D1, D2, & D3 for "shorts" or "opens". Keep in mind that unless these devices are electrically isolated from the circuit, some resistance will be read in both polarities. See the Wiring Diagram.

Figure F.4

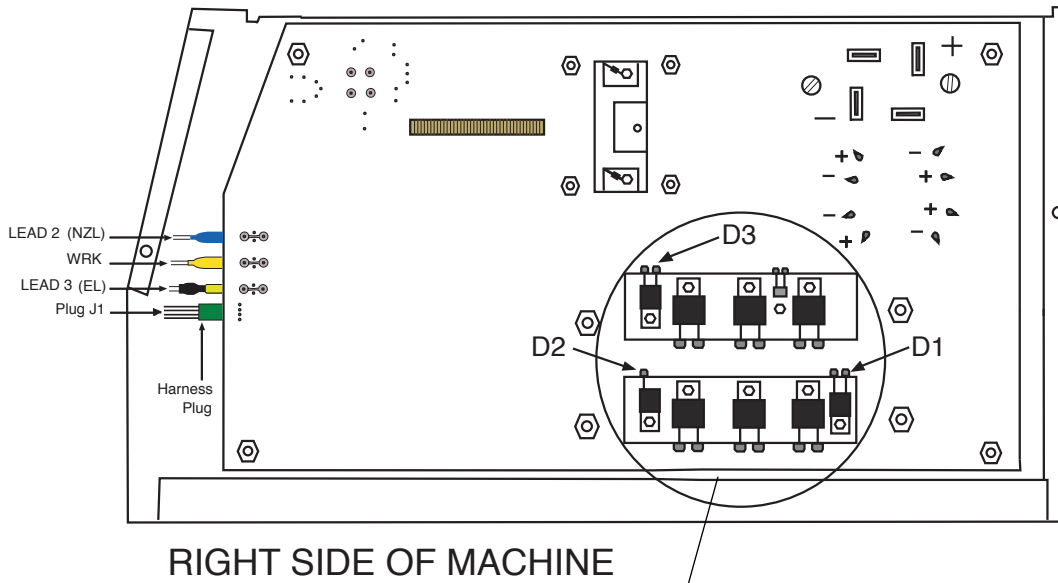

RIGHT SIDE OF MACHINE

D1, D2, & D3

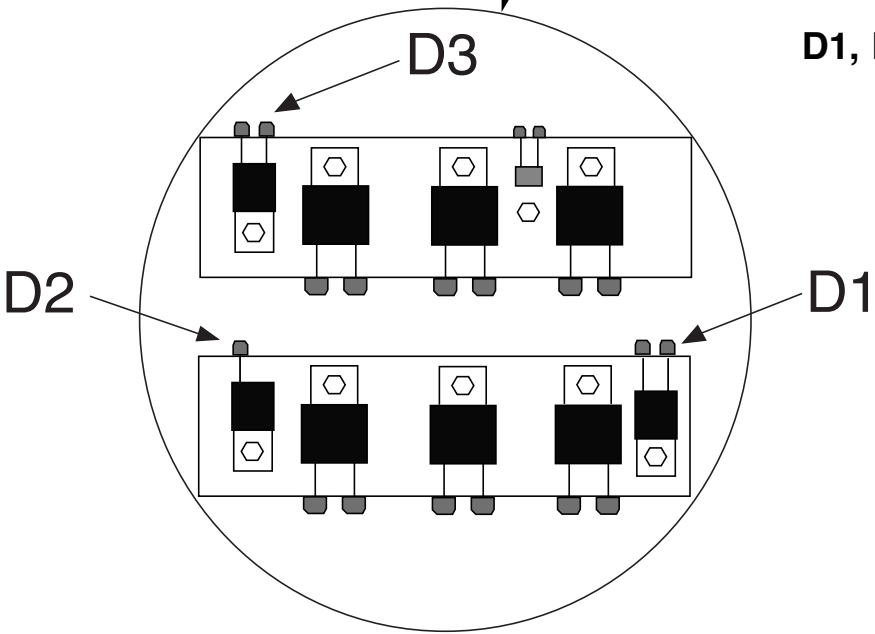

PRO-CUT® 25



Return to Section TOC

Return to Section TOC

Return to Section TOC

Return to Section TOC

Return to Master TOC

Return to Master TOC

Return to Master TOC

Return to Master TOC

MAIN INVERTER BOARD RESISTANCE TEST (continued)

- 10. Remove the torch consumables. (Shield cup, Nozzle and Electrode)
- 11. With the Torch Consumables removed test the output diodes. (D10 and D11) See the Wiring Diagram.
- 12. With the Torch Consumables removed test the snubber diodes. (D8 and D9) See the Wiring Diagram. See Figure F.5.
- 13. Replace the torch consumables previously removed. Check the resistance across output diode D11. The resistance should be very low, near or at zero ohms. This verifies that the pilot arc circuit is complete. See the Wiring Diagram.

Figure F.5

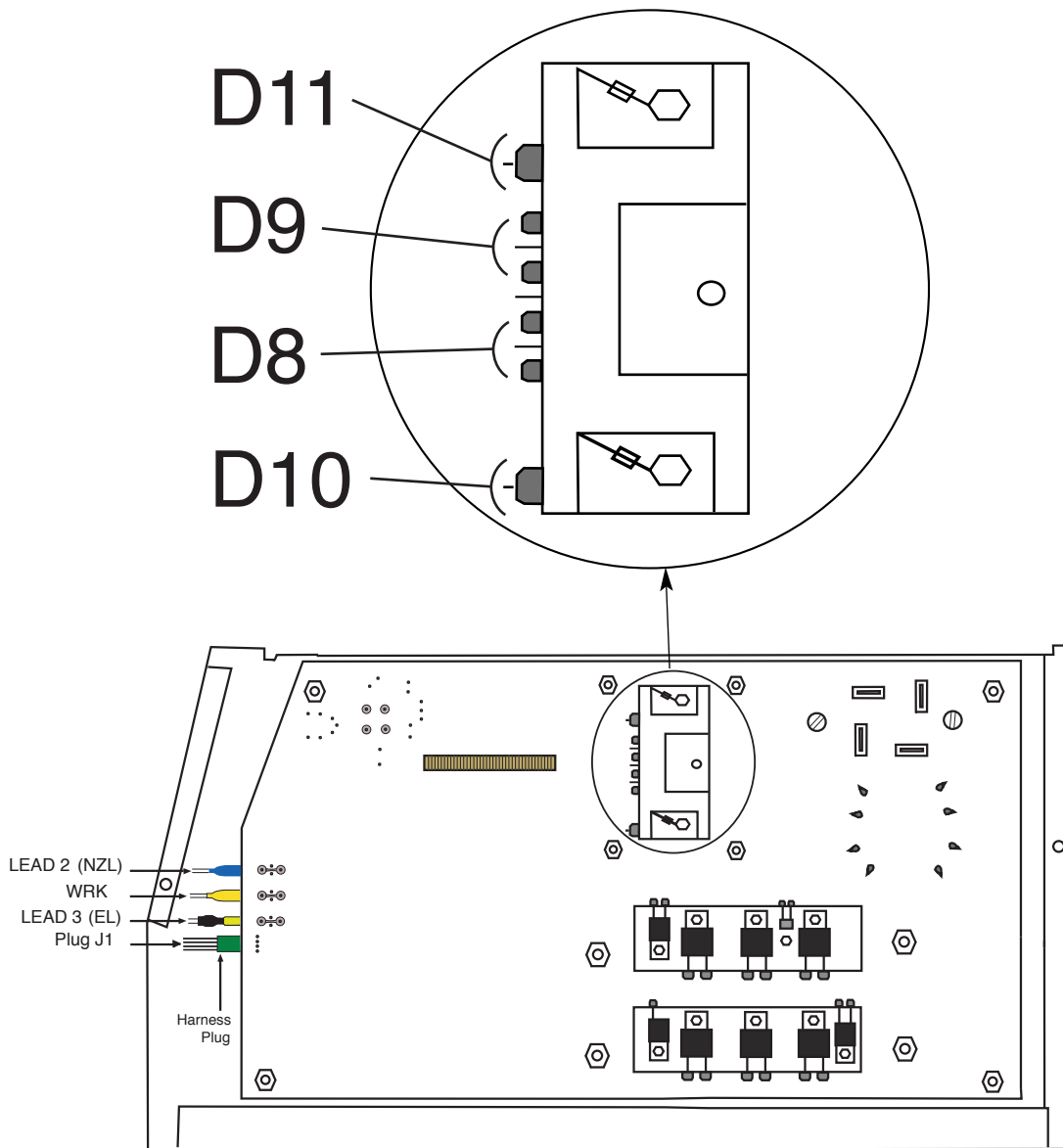

RIGHT SIDE OF MACHINE

PRO-CUT® 25



Return to Section TOC

Return to Master TOC

Return to Section TOC
Return to Master TOC

Return to Section TOC
Return to Master TOC

Return to Section TOC
Return to Master TOC

Return to Section TOC
Return to Master TOC

PRO-CUT® 25



INPUT BOARD VOLTAGE TEST



WARNING

Service and repair should be performed by only Lincoln Electric factory trained personnel. Unauthorized repairs performed on this equipment may result in danger to the technician or machine operator and will invalidate your factory warranty. For your safety and to avoid electrical shock, please observe all safety notes and precautions detailed throughout this manual.

If for any reason you do not understand the test procedures or are unable to perform the test/repairs safely, contact the Lincoln Electric Service Department for electrical troubleshooting assistance before you proceed. Call 1-888-935-3877.

DESCRIPTION

This test will help determine if the correct input voltage is being applied to the Input Board and will also determine if the correct voltages are being processed and regulated on the Input Board.

MATERIALS NEEDED

- Volt/Ohmmeter
- 7mm Nut Driver
- 4mm Allen Wrench
- Crescent Wrench

PRO-CUT® 25



INPUT BOARD VOLTAGE TEST (CONTINUED)

TEST PROCEDURE

1. Remove input power to the **PRO-CUT®** 25 machine.
2. Remove carrying handle using a 4mm allen wrench.
3. Using a crescent wrench, carefully remove the plastic nut from around the pressure regulator located on the top of the machine.
4. Using a 7mm nut driver, remove the case wraparound.
5. Perform the **Input Filter Capacitor Discharge Procedure** detailed earlier in this section.
6. Visually check for burned or damaged components on the input board. If any components are physically damaged or determined to be faulty (except the fuse) the input board should be replaced.
7. Check fuse F1 (1 amp). Replace if defective.
8. Apply 115VAC input to the **PRO-CUT®** 25 machine. The test should be performed with 115VAC applied. Not 230VAC.

NOTE: If the peak input voltage is above 400VAC the thermal light may activate. Reduce the input voltage.

9. Turn on the machine and carefully check for 115VAC (+/- 10%) at points A and B. See Figure F.6. See the Wiring Diagram.

NOTE: Within 4 seconds of the machine being turned on, the two relays RL2 and RL3 should activate. If they don't, the input board is faulty.

Figure F.6 Input Board Description

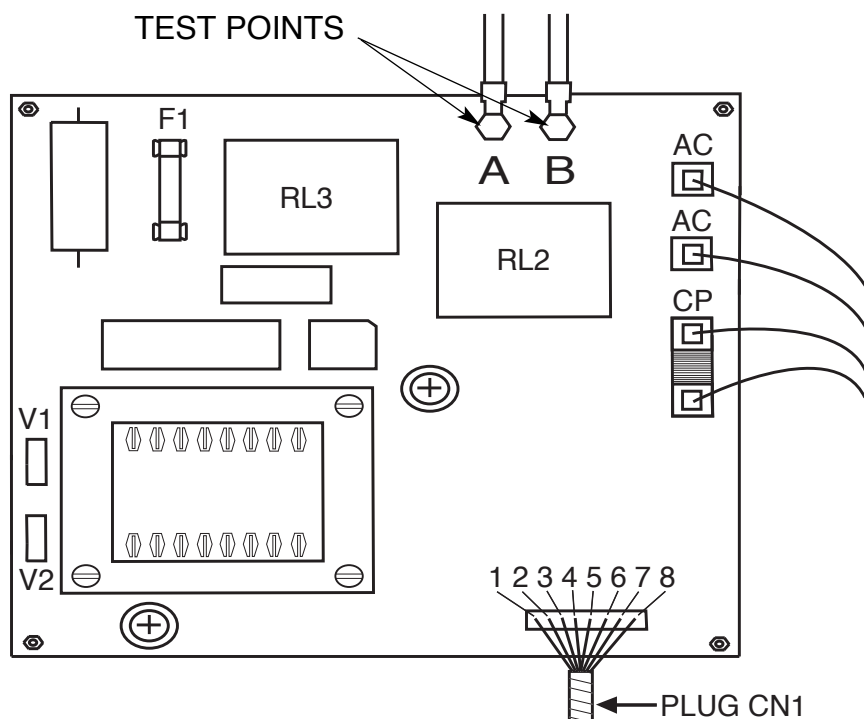

PRO-CUT® 25

LINCOLN
ELECTRIC

INPUT BOARD VOLTAGE TEST (CONTINUED)

- 10. After the relays activate, check for 115VAC from both test points AC to CP. See Figure F.7. If this voltage is not present or low, the relay contacts may be defective.
 - 11. Check the fan voltage at the fan terminals (V1 & V2). See Figure F.7. Normal is 230VAC. If this voltage is normal (230VAC), the primary circuit of the auxiliary transformer is operating correctly.
 - 12. Check for the presence of approximately 15VAC at pins 1 and 2 of plug CN1. See Figure F.7.
 - 13. With the torch consumables in place (nozzle, electrode and shield) check for the presence of approximately 6VDC at pins 3(-) and 4(+) of plug CN1. See Figure F.7.
- NOTE:** With the torch consumables removed this voltage should be approximately 26VDC.
- 14. If the relays (RL2 and RL3) are activating with 115VAC applied to the machine and the above test voltages are correct the input board is functioning correctly.

Figure F.7 Input Board Test Points

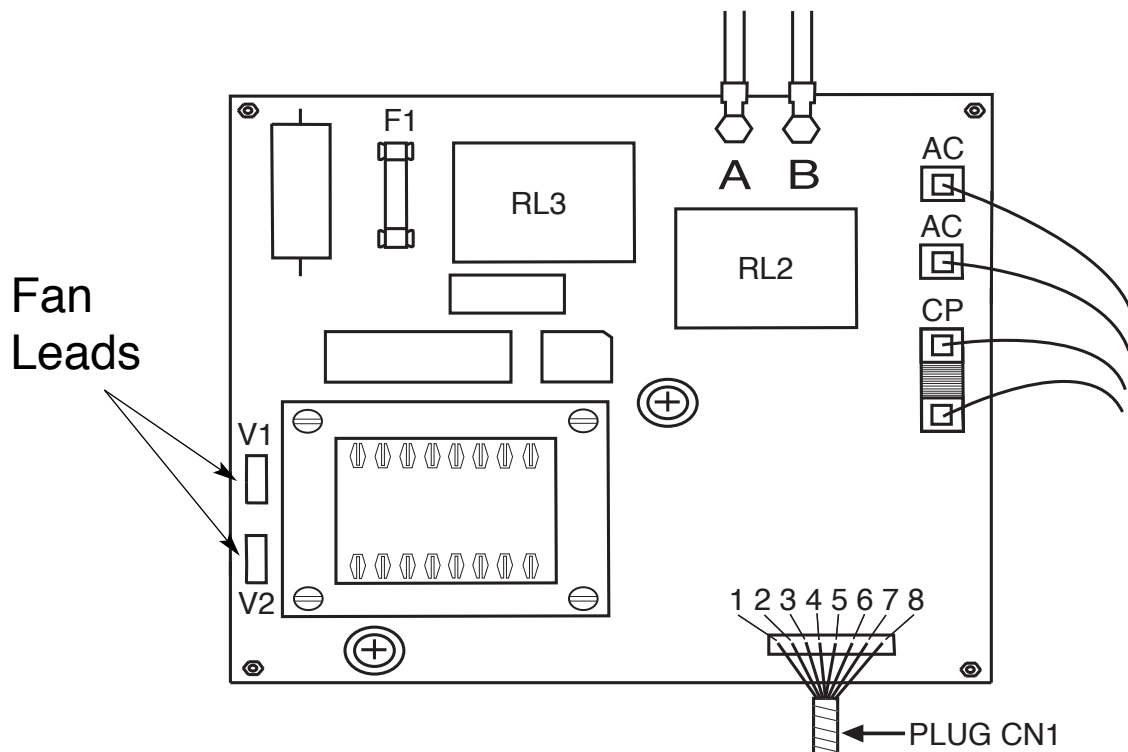

Return to Section TOC

Return to Master TOC

Return to Section TOC

Return to Master TOC

Return to Section TOC

Return to Master TOC

Return to Section TOC

Return to Master TOC

Return to Section TOC
Return to Master TOC

Return to Section TOC
Return to Master TOC

Return to Section TOC
Return to Master TOC

Return to Section TOC
Return to Master TOC

PRO-CUT® 25



TROUBLESHOOTING & REPAIR

MAIN INVERTER BOARD VOLTAGE TEST



WARNING

Service and repair should be performed by only Lincoln Electric factory trained personnel. Unauthorized repairs performed on this equipment may result in danger to the technician or machine operator and will invalidate your factory warranty. For your safety and to avoid electrical shock, please observe all safety notes and precautions detailed throughout this manual.

If for any reason you do not understand the test procedures or are unable to perform the test/repairs safely, contact the Lincoln Electric Service Department for electrical troubleshooting assistance before you proceed. Call 1-888-935-3877.

DESCRIPTION

This test will help determine if the Main Inverter Board is receiving the correct input voltages and if the correct regulated voltages are being processed and maintained by the Main Inverter Board.

MATERIALS NEEDED

- Volt/Ohmmeter
- 7mm Nut Driver
- 4mm Allen Wrench
- Crescent Wrench

PRO-CUT® 25



MAIN INVERTER BOARD VOLTAGE TEST (CONTINUED)

TEST PROCEDURE

1. Remove input power to the **PRO-CUT®** 25 machine.
2. Remove carrying handle using a 4mm allen wrench.
3. Using a crescent wrench, carefully remove the plastic nut from around the pressure regulator located on the top of the machine.
4. Using a 7mm nut driver, remove the case wraparound.
5. Perform the **Input Filter Capacitor Discharge Procedure** detailed earlier in this section.
6. Visually check for burned or damaged components on the input board. If any components are physically damaged or determined to be faulty (except the fuse) the input board should be replaced.
7. Apply the correct input power to the **PRO-CUT®** 25 machine. (115VAC or 230VAC)
8. Carefully test for approximately 300VDC at the P1 bridge terminals. See Figure F.8. This represents the rectified voltage supplied from the input board. See the Wiring Diagram.
9. Carefully test for approximately 15VAC at the test points on bridge P2. This is the control supply voltage from the input board. See Figure F.8. See the Wiring Diagram.
10. Carefully test for 12VDC at test points C17. See Figure F.8. See Wiring Diagram. This is the rectified and regulated DC supply voltage for the inverter board control circuitry.

Figure F.8. Test Points

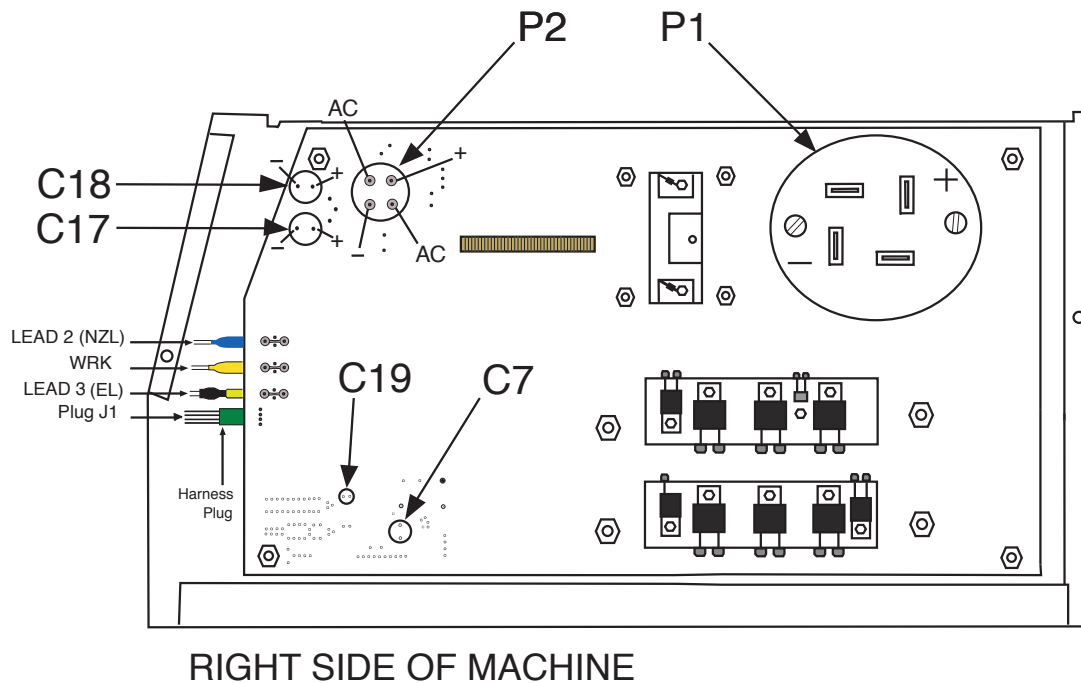

PRO-CUT® 25

LINCOLN
ELECTRIC

MAIN INVERTER BOARD VOLTAGE TEST (CONTINUED)

- 10. Carefully test for 12VDC at test points C7. See Figure F.9. See the Wiring Diagram. This is the rectified and regulated supply for the pulse width modulation circuit.
- 11. Carefully test for 12VDC at C18 test points. If it is not correct, the control board or associated wiring may be faulty. See the Wiring Diagram. See Figure F.9.
- 12. Carefully check for the presence of 8VDC at C19 test points. If not correct, the control board or associated wiring may be faulty. See Figure F.9. See the Wiring Diagram.

Figure F.9 Test Points

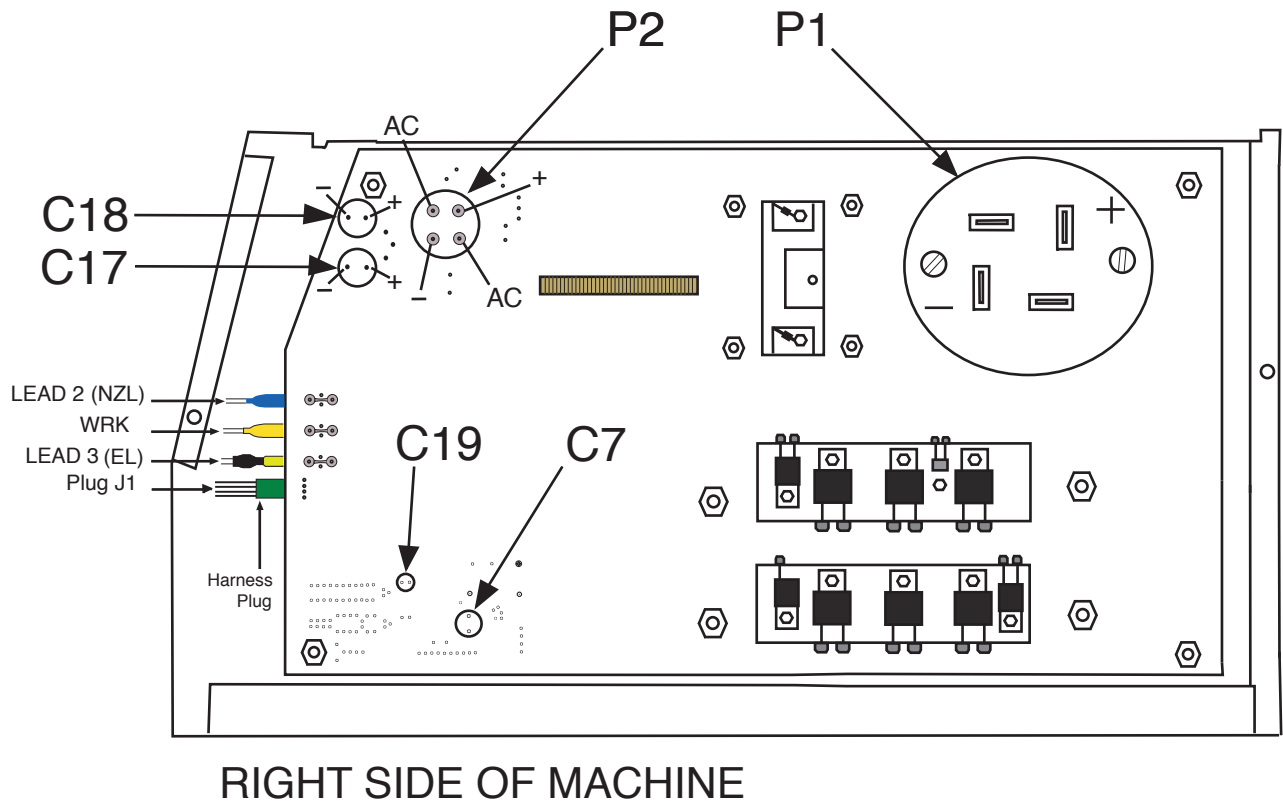

Return to Section TOC

Return to Section TOC

Return to Section TOC

Return to Section TOC

Return to Master TOC

Return to Master TOC

Return to Master TOC

Return to Master TOC

NOTES

Return to Section TOC
Return to Master TOC

Return to Section TOC
Return to Master TOC

Return to Section TOC
Return to Master TOC

Return to Section TOC
Return to Master TOC

PRO-CUT® 25



TORCH CONTINUITY AND SOLENOID TEST



WARNING

Service and repair should be performed by only Lincoln Electric factory trained personnel. Unauthorized repairs performed on this equipment may result in danger to the technician or machine operator and will invalidate your factory warranty. For your safety and to avoid electrical shock, please observe all safety notes and precautions detailed throughout this manual.

If for any reason you do not understand the test procedures or are unable to perform the test/repairs safely, contact the Lincoln Electric Service Department for electrical troubleshooting assistance before you proceed. Call 1-888-935-3877.

DESCRIPTION

This procedure will help the technician determine if the Torch Cable, Consumables and Electrode Solenoid are functioning properly.

MATERIALS NEEDED

- Volt/Ohmmeter
- 12 VDC @ 1 Amp Power Supply
- 7mm Nut Driver
- 4mm Allen Wrench
- Crescent Wrench

PRO-CUT® 25



TORCH CONTINUITY AND SOLENOID TEST (*continued*)

FIGURE F.10

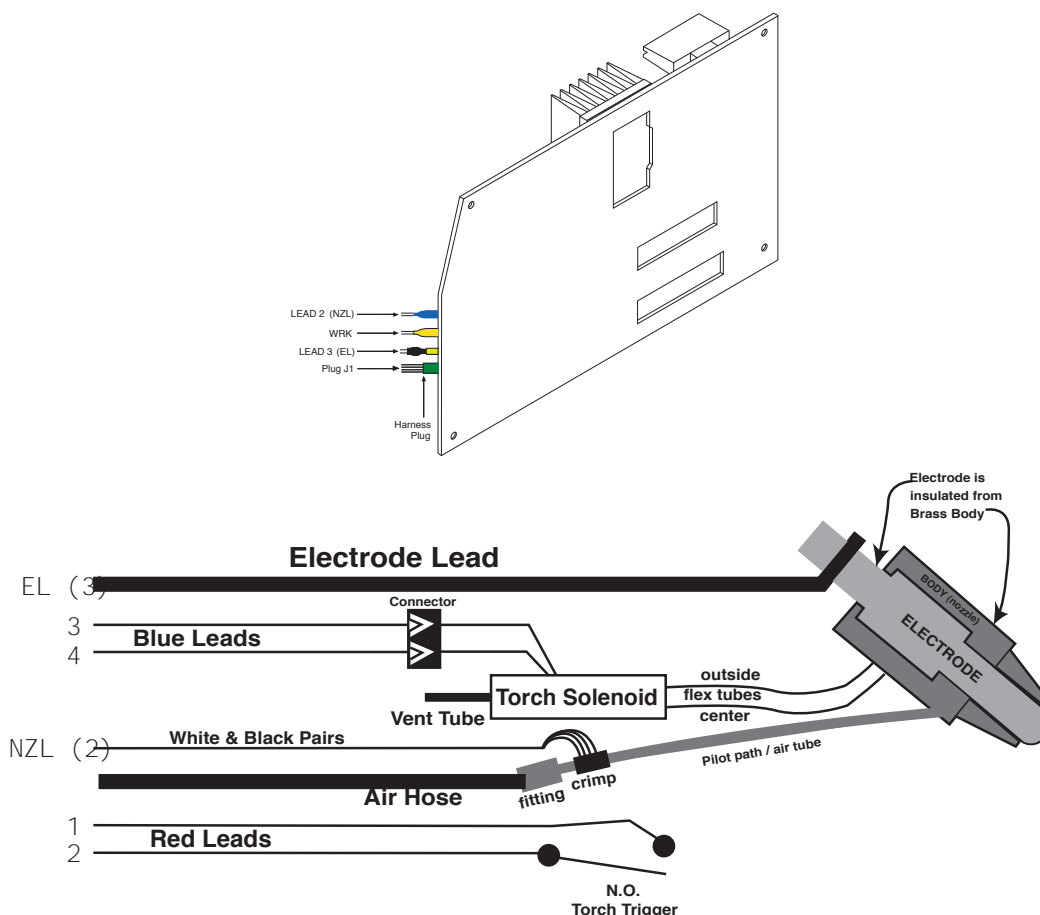

TEST PROCEDURE

1. Remove nozzle, remove electrode, reinstall nozzle and turn on machine. Safety/fault LED should light, if not, torch is shorted. Replace. If safety/fault LED glows, continue with test.
2. Remove input power to the PRO-CUT® 25 machine.
3. Remove carrying handle using a 4mm allen wrench.
4. Using a crescent wrench, carefully remove the plastic nut from around the pressure regulator located on the top of the machine.
5. Using a 7mm nut driver, remove the case wraparound.
6. Perform the **Input Filter Capacitor Discharge Procedure**.
7. Remove Plug J1, Lead #2, and Lead #3 from the Main Inverter Board. See Figure F.10
8. Using the ohmmeter, check the torch resistances per **Table F.1**.
9. If any of the resistance checks are not correct, the torch assembly may be faulty. Repair or replace.
10. With connector J1 disconnected from the P.C. Board carefully apply the 12 VDC supply to the electrode solenoid. (positive to Plug J1 Pin #4 and Negative to Pin #3). The electrode solenoid should activate. Listen for the solenoid action in the torch handle. If the solenoid does not activate, it may be faulty. Replace. See Figures F.10 & F.11.

PRO-CUT® 25

TORCH CONTINUITY AND SOLENOID TEST *(continued)*

TABLE F.1 - TORCH ASSEMBLY RESISTANCES			
TEST POINTS	CIRCUIT(S) BEING TESTED	EXPECTED RESISTANCE	TEST CONDITIONS
Lead #2 To Lead #3	Pilot arc leads	1.5 ohms maximum	Torch consumables in place
Lead #2 to Torch Nozzle	Pilot arc lead to nozzle	1.0 ohm maximum	Torch consumables in place
Lead #3 to Torch Nozzle	Pilot arc lead to nozzle	1.0 ohm maximum	Torch consumables in place
Pin 1 to Pin 2 Plug J1 (Red Leads)	Torch trigger circuit	100K ohms minimum	Torch trigger NOT pulled (not activated)
Pin 1 to Pin 2 Plug J1 (Red Leads)	Torch trigger circuit	1.0 ohm maximum	Torch trigger pulled (activated)
Pin 3 to Pin 4 Plug J1 (Gray Leads)	Electrode Solenoid	45 to 55 ohms	None

Figure F.11

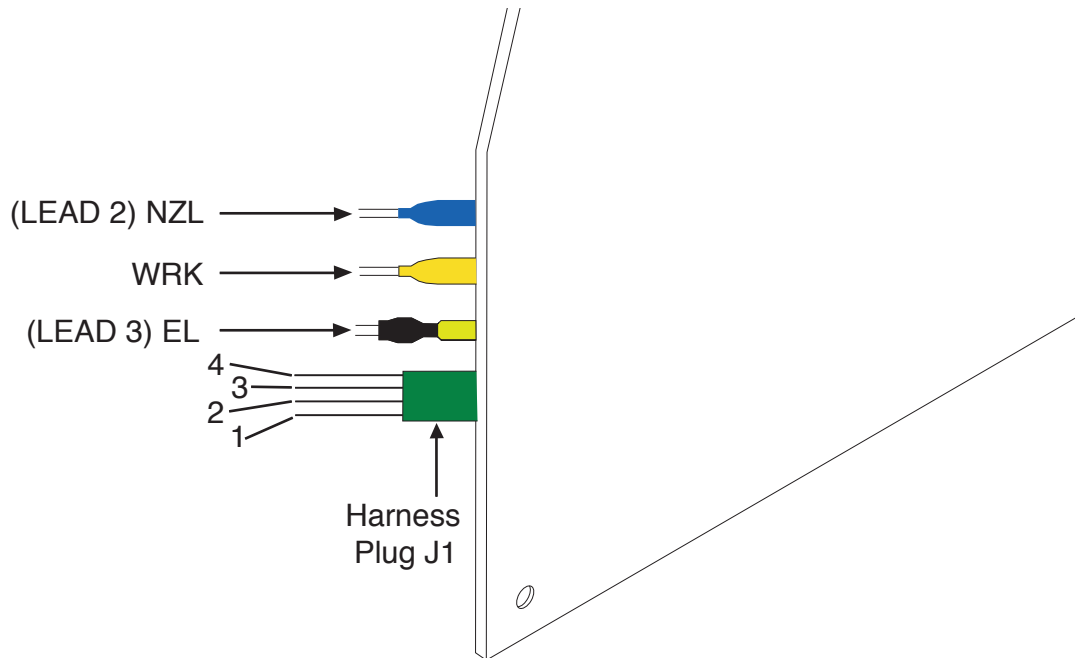

11. Torch circuits may be measured when electrode and nozzle are in place if the various circuits are isolated from each other. NZL (2), Electrode (3), Trigger (1,2), and Torch leads (3,4) should all measure greater than 1 Meg ohm when checked as isolated circuits. See **Figure F.10** Diagram.

12. Replace leads and plugs previously removed.

Return to Section TOC
Return to Master TOC

NOTES

Return to Section TOC
Return to Master TOC

Return to Section TOC
Return to Master TOC

Return to Section TOC
Return to Master TOC

Return to Section TOC
Return to Master TOC

PRO-CUT® 25



AIR/GAS SOLENOID TEST**WARNING**

Service and repair should be performed by only Lincoln Electric factory trained personnel. Unauthorized repairs performed on this equipment may result in danger to the technician or machine operator and will invalidate your factory warranty. For your safety and to avoid electrical shock, please observe all safety notes and precautions detailed throughout this manual.

If for any reason you do not understand the test procedures or are unable to perform the test/repairs safely, contact the Lincoln Electric Service Department for electrical troubleshooting assistance before you proceed. Call 1-888-935-3877.

DESCRIPTION

This procedure will help the technician determine if the Solenoid is functioning properly.

MATERIALS NEEDED

- 4mm Allen Wrench
- 7mm Nut Driver
- 12 VDC @ 3 Amp Power Supply
- Volt/Ohmmeter
- Crescent Wrench

PRO-CUT® 25

LINCOLN[®]
ELECTRIC

AIR/GAS SOLENOID TEST (continued)

FIGURE F.12 – AIR SOLENOID

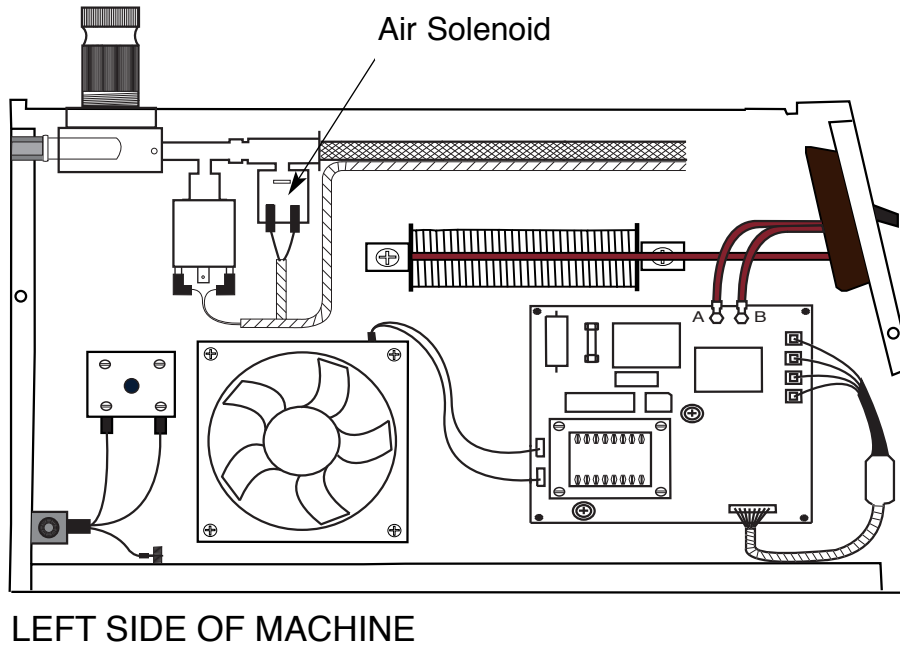

TEST PROCEDURE

1. Remove input power to the **PRO-CUT® 25** machine.
2. Remove carrying handle using a 4mm allen wrench.
3. Using a crescent wrench, carefully remove the plastic nut from around the pressure regulator located on the top of the machine.
4. Using a 7mm nut driver, remove the case wraparound.
5. Perform the **Input Filter Capacitor Discharge Procedure** detailed earlier in this section.
6. Locate the air solenoid and leads. Carefully remove the two leads from the Solenoid. See Figure F.12.
7. Check the coil resistance of the solenoid at the two terminals. Normal resistance is approximately 13 ohms. If the resistance is abnormal, the Solenoid may be defective.
8. Carefully apply the 12 VDC supply to the solenoids lower two terminals. With proper air pressure applied, the solenoid should activate and air should flow from the torch nozzle. If the solenoid activates but air does not flow, check for a restriction in the air line or torch.
9. Reinstall the two leads previously removed.

PRO-CUT® 25

LINCOLN
ELECTRIC

CONTROL BOARD REMOVAL AND REPLACEMENT



WARNING

Service and repair should be performed by only Lincoln Electric factory trained personnel. Unauthorized repairs performed on this equipment may result in danger to the technician or machine operator and will invalidate your factory warranty. For your safety and to avoid electrical shock, please observe all safety notes and precautions detailed throughout this manual.

If for any reason you do not understand the test procedures or are unable to perform the test/repairs safely, contact the Lincoln Electric Service Department for electrical troubleshooting assistance before you proceed. Call 1-888-935-3877.

DESCRIPTION

The following procedure will aid the technician in removing the Control Board for maintenance or replacement.

MATERIALS NEEDED

- Crescent Wrench
- Small Flathead Screwdriver
- 7mm Nut Driver
- 6mm Nut Driver
- 4mm Allen Wrench
- 2.5mm Allen Wrench
- Needle Nose Pliers

PRO-CUT® 25



Return to Section TOC

Return to Section TOC

Return to Section TOC

Return to Section TOC

Return to Master TOC

Return to Master TOC

Return to Master TOC

Return to Master TOC

CONTROL BOARD REMOVAL AND REPLACEMENT *(continued)*

FIGURE F.13 - CONTROL BOARD LOCATION

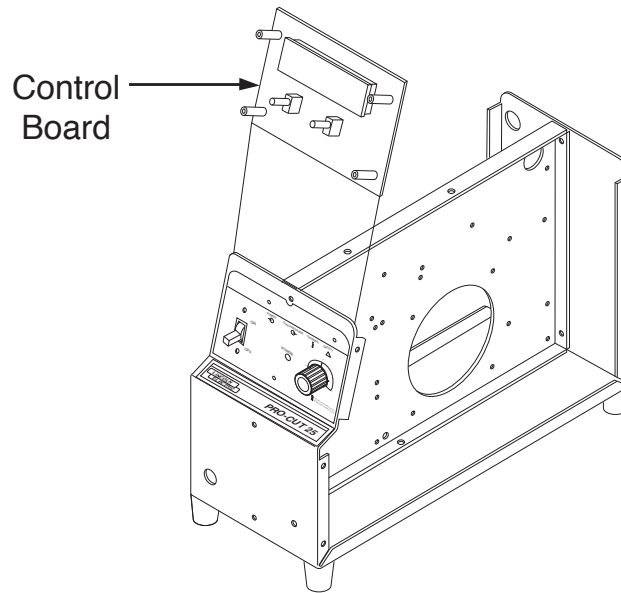

PROCEDURE

1. Remove input power to the **PRO-CUT® 25** machine.
2. Remove carrying handle using a 4mm allen wrench.
3. Using a crescent wrench, carefully remove the plastic nut from around the pressure regulator located on the top of the machine.
4. Using a 7mm nut driver, remove the case wrap-around.
5. Perform ***Input Filter Capacitor Discharge Procedure.***
6. Using a very small flathead screwdriver or a thin knife blade, carefully remove the red plastic cap from the front of the plastic OUTPUT knob located on the front of the machine. See Figure F14.

FIGURE F.14 - SMALL RED CAP REMOVAL

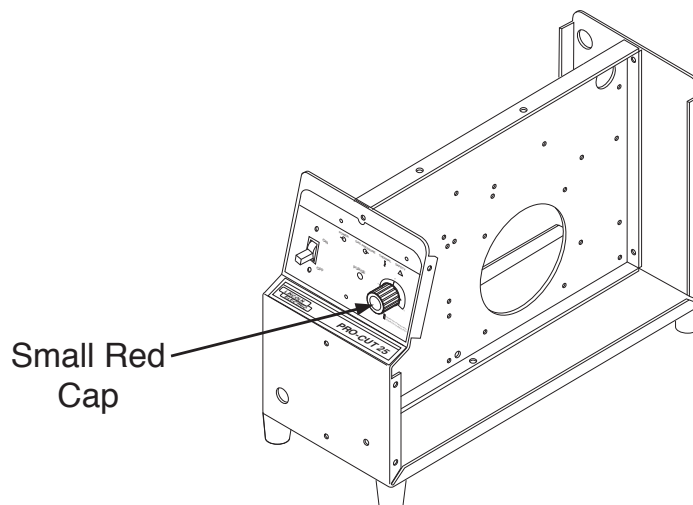

PRO-CUT® 25

LINCOLN®
ELECTRIC

CONTROL BOARD REMOVAL AND REPLACEMENT *(continued)*

7. A nut is located under the red plastic piece that you previously removed. Loosen this nut with a 6mm nut driver and remove. Plastic alignment spacer may come off with knob.
8. Next to the knob is a Red button that reads "PURGE". Remove it by gently pulling.

FIGURE F.15 - CASE FRONT SCREW REMOVAL

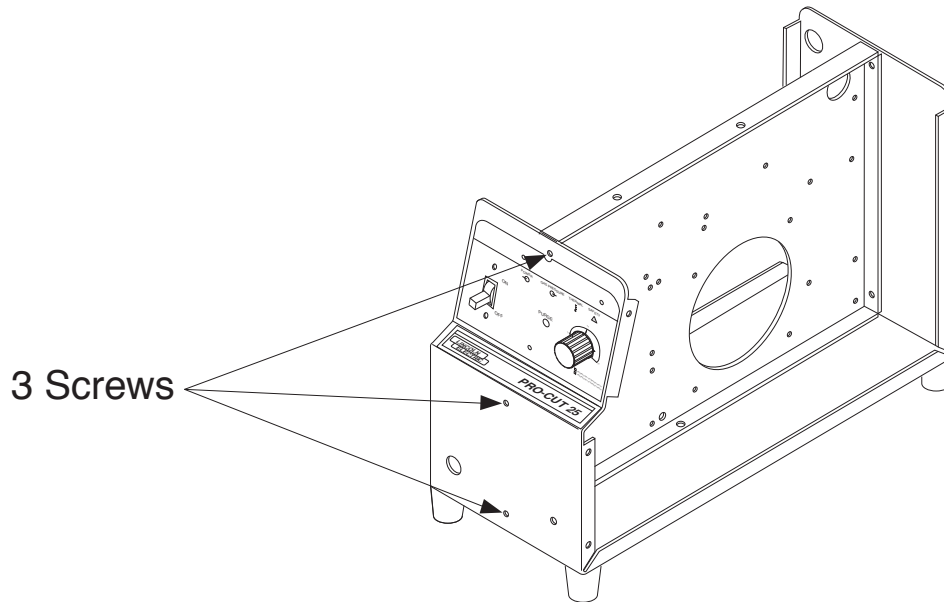

CAUTION

Be sure to follow the recommended static-free methods for **handling printed circuit boards**. Failure to do so can result in permanent damage to the equipment.

9. Using a 7mm nut driver remove the three screws that hold the case front to the central metal wall. This will allow the case front to be gently pulled forward so the Control board can be removed. See Figure F.15.
10. Remove the four allen bolts with a 2.5 mm allen wrench.
11. Carefully remove the plug and lead assembly from the control board.
12. At this point, the control board is ready for removal. GENTLY pull the case front forward and carefully remove the Control board.
13. Replace the Control Board by GENTLY pulling the case front forward and carefully sliding the Control board back into its original position. Reconnect plug and lead assembly.
14. Replace the four allen mounting screws.
15. Replace the screws connecting the case front to the central metal wall.

PRO-CUT® 25

LINCOLN
ELECTRIC

CONTROL BOARD REMOVAL AND REPLACEMENT *(continued)*

16. Replace the red PURGE button.
17. Replace the plastic OUTPUT knob, align it in its original position, and tighten nut.
18. Replace the red cap on the end of the OUTPUT knob.
19. Replace the case wraparound.
20. Replace the plastic nut from around the pressure regulator. **Do Not Over Tighten.**
21. Replace the carry handle.

Return to Section TOC

Return to Section TOC

Return to Section TOC

Return to Section TOC

Return to Master TOC

Return to Master TOC

Return to Master TOC

Return to Master TOC

PRO-CUT® 25



INPUT BOARD REMOVAL AND REPLACEMENT



WARNING

Service and repair should be performed by only Lincoln Electric factory trained personnel. Unauthorized repairs performed on this equipment may result in danger to the technician or machine operator and will invalidate your factory warranty. For your safety and to avoid electrical shock, please observe all safety notes and precautions detailed throughout this manual.

If for any reason you do not understand the test procedures or are unable to perform the test/repairs safely, contact the Lincoln Electric Service Department for electrical troubleshooting assistance before you proceed. 1-888-935-3877.

DESCRIPTION

The following procedure will aid the technician in removing the Input Board for maintenance or replacement.

MATERIALS NEEDED

- 4 mm Allen Wrench
- Crescent Wrench
- 7 mm Nut Driver
- Needle Nose Pliers

PRO-CUT® 25



INPUT BOARD REMOVAL & REPLACEMENT *(continued)*

FIGURE F.16 Input Board Location

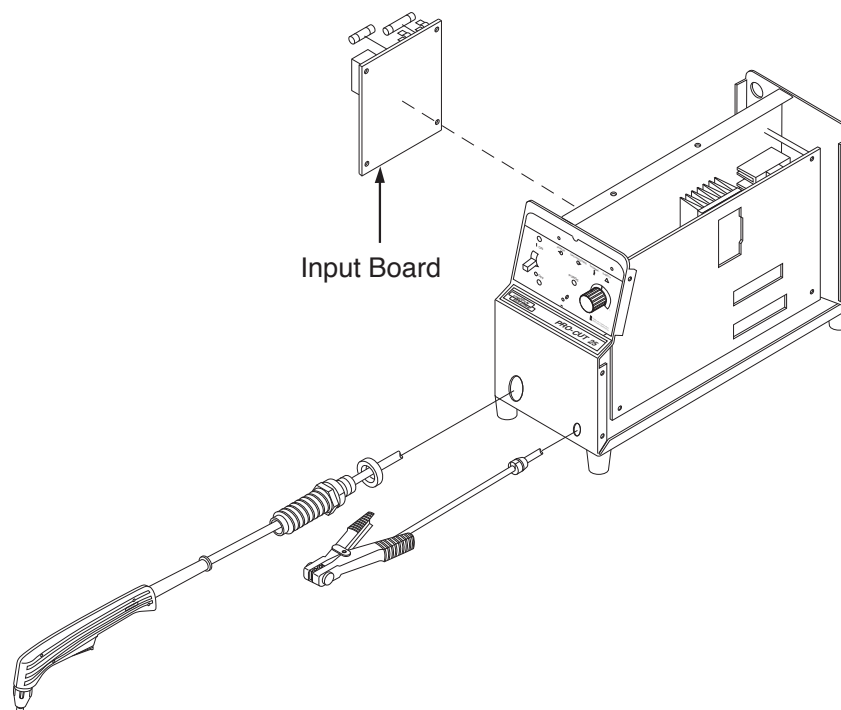

PROCEDURE

1. Remove input power to **PRO-CUT® 25**.
2. Remove carrying handle using a 4mm allen wrench.
3. Using a crescent wrench, carefully remove the plastic nut from around the pressure regulator located on the top of the machine.
4. Using a 7mm nut driver, remove the case wrap-around.
5. Perform ***Input Filter Capacitor Discharge Procedure***.
6. Note the orientation of the input board to avoid confusion during reassembly.
7. Carefully label and remove cooling fan leads from Input Board. Pliers may be necessary. ***See Figure F.17.***
8. Remove harness plug from lower right hand corner of board. Pliers may be necessary. ***See Figure F.17.***
9. Directly above the harness in step 8, there are four leads, CP(2) and AC(2). Label these leads and remove. Pliers may be necessary.
10. Using a 7mm nut driver, remove the two leads from terminals A and B on the input board.



CAUTION

Be sure to follow the recommended static-free methods for ***handling printed circuit boards***. Failure to do so can result in permanent damage to the equipment.

NOTE: The lead posts on the Input Board are labeled with an "A" and a "B", so label the lead wires accordingly upon removal. Be careful not to misplace washers when bolts are removed. ***See Figure F.17.***

PRO-CUT® 25



INPUT BOARD REMOVAL & REPLACEMENT *(continued)*

FIGURE F.17 – INPUT BOARD REMOVAL

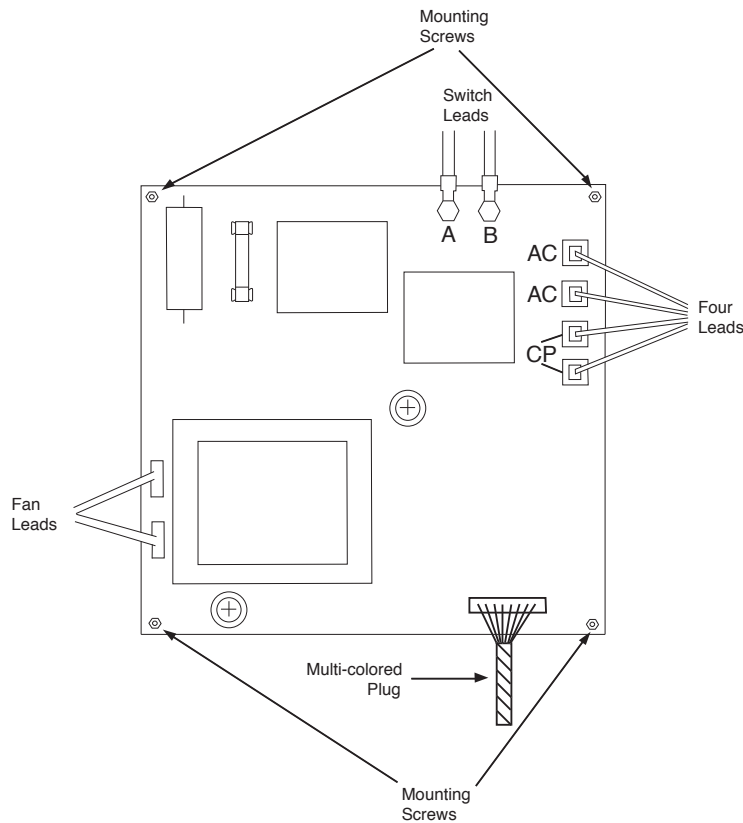

11. Using a 7mm Nut driver, remove the four mounting nuts from the corners of the Input Board. Be careful not to lose the washer behind each nut. Input Board can be removed after these four nuts are removed.
12. After replacement of the Input Board, replace the four nuts and washers previously removed from the corners of the board. **Do Not Over tighten.**
13. Using a 7 mm nut driver replace two leads originating from the Input Switch. (A+B)
14. Reconnect four leads in their correct positions. (AC and CP)
15. Reconnect the harness plug.
16. Reconnect the fan leads to the Input Board. Be sure that leads are connected to their original positions.
17. Replace the case wraparound.
18. Replace the plastic nut from around the pressure regulator. **Do Not Over tighten.**
19. Replace the carry handle.

Return to Section TOC
Return to Master TOC

Return to Section TOC
Return to Master TOC

Return to Section TOC
Return to Master TOC

Return to Section TOC
Return to Master TOC

PRO-CUT® 25



MAIN INVERTER BOARD REMOVAL AND REPLACEMENT



WARNING

Service and repair should be performed by only Lincoln Electric factory trained personnel. Unauthorized repairs performed on this equipment may result in danger to the technician or machine operator and will invalidate your factory warranty. For your safety and to avoid electrical shock, please observe all safety notes and precautions detailed throughout this manual.

If for any reason you do not understand the test procedures or are unable to perform the test/repairs safely, contact the Lincoln Electric Service Department for electrical troubleshooting assistance before you proceed. Call 1-888-935-3877.

DESCRIPTION

The following procedure will aid the technician in removing the Main Inverter Board for maintenance or replacement.

MATERIALS NEEDED

- 4mm Allen Wrench
- Crescent Wrench
- 7mm Nut Driver
- Needle Nose Pliers

MAIN INVERTER BOARD REMOVAL & REPLACEMENT *(continued)*

FIGURE F.18 – MAIN INVERTER BOARD REMOVAL

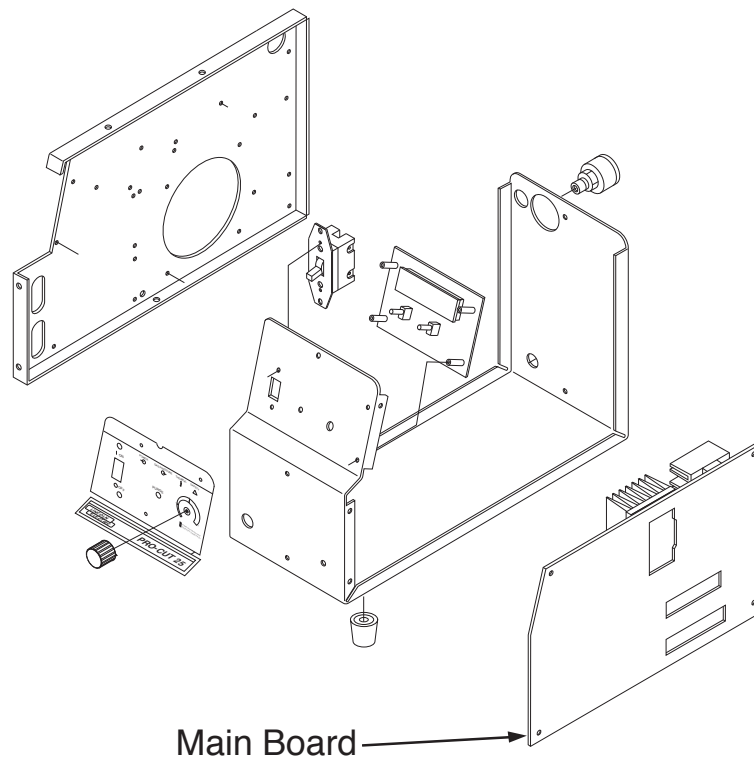

PROCEDURE

1. Remove input power to **PRO-CUT® 25**.
2. Remove carrying handle using a 4mm allen wrench.
3. Using a crescent wrench, carefully remove the plastic nut from around the pressure regulator located on the top of the machine.
4. Using a 7mm nut driver, remove the case wrap-around.
5. Perform **Input Filter Capacitor Discharge Procedure**.
6. Locate the Main Board, all associated leads and plug connections.
7. Label the leads and note their positions for reassembly.
8. Using a 7mm Nut driver, remove the four nuts and washers located at the corners of the main board. (This will allow you to gently manipulate the board for labeling and removal of all Leads.)
9. Remove the two harness plugs from front top corner of board. Label and remove the four single leads from the rear top corner of board. Carefully remove NZL, WRK, and EL leads from lower front of board. Also remove harness plug (J1). **See Figure F.19.**
10. Remove board.



CAUTION

Be sure to follow the recommended static-free methods for **handling printed circuit boards**. Failure to do so can result in permanent damage to the equipment.

PRO-CUT® 25



MAIN INVERTER BOARD REMOVAL & REPLACEMENT *(continued)*

FIGURE F.19 – INVERTER BOARD LEAD LOCATIONS

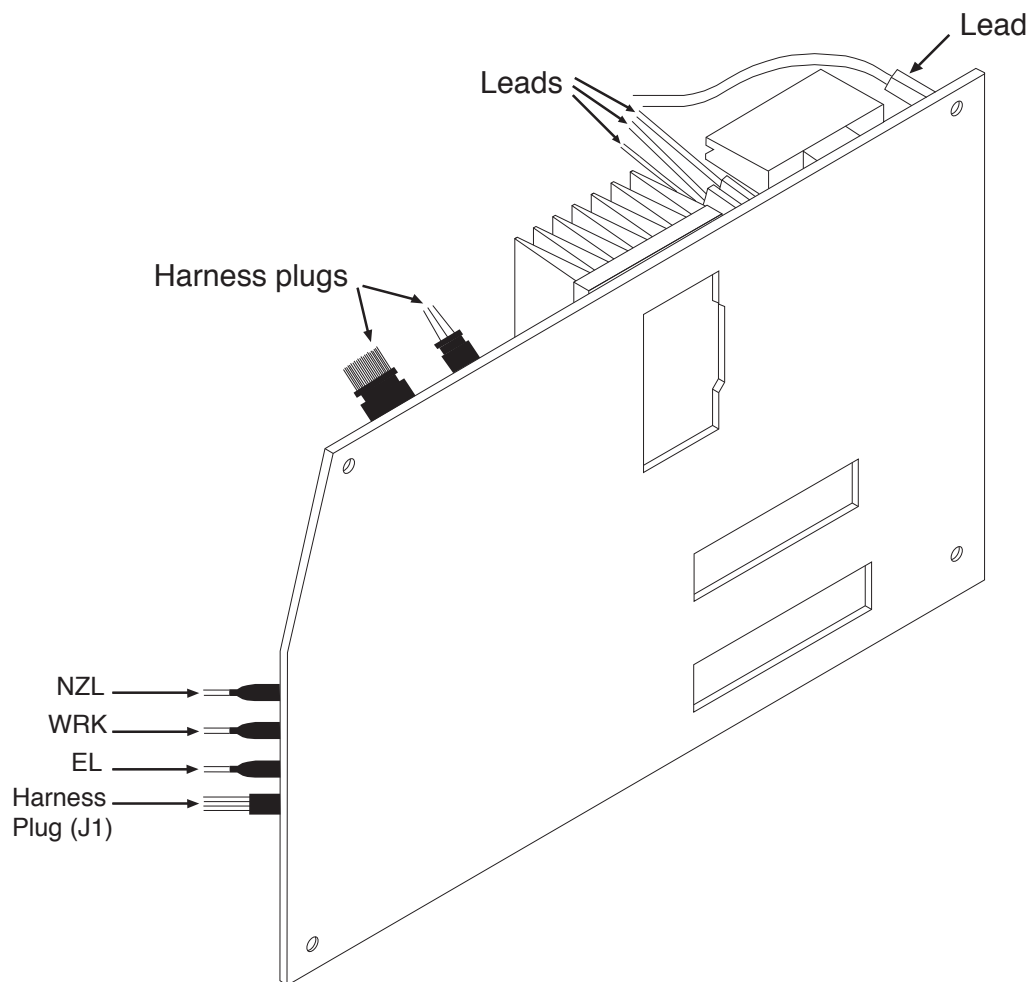

11. Reconnect all leads to the new board.
12. Replace the four bolts and washers previously removed from the corners of the board.
13. Replace the case wraparound.
14. Replace the plastic nut from around the pressure regulator. **Do Not Over Tighten.**
15. Replace the carry handle.

PRO-CUT® 25

LINCOLN
ELECTRIC

Return to Section TOC
Return to Master TOC

Return to Section TOC
Return to Master TOC

Return to Section TOC
Return to Master TOC

Return to Section TOC
Return to Master TOC

PRO-CUT® 25



SWITCH REMOVAL AND REPLACEMENT



WARNING

Service and repair should be performed by only Lincoln Electric factory trained personnel. Unauthorized repairs performed on this equipment may result in danger to the technician or machine operator and will invalidate your factory warranty. For your safety and to avoid electrical shock, please observe all safety notes and precautions detailed throughout this manual.

If for any reason you do not understand the test procedures or are unable to perform the test/repairs safely, contact the Lincoln Electric Service Department for electrical troubleshooting assistance before you proceed. Call 1-888-935-3877.

DESCRIPTION

The following procedure will aid the technician in removing the Switch for maintenance or replacement.

MATERIALS NEEDED

- 4 mm Allen Wrench
- Crescent Wrench
- 7 mm Nut Driver
- Phillips Head Screwdriver
- Flat Head Screwdriver

PRO-CUT® 25



Return to Section TOC

Return to Section TOC

Return to Section TOC

Return to Section TOC

Return to Master TOC

Return to Master TOC

Return to Master TOC

Return to Master TOC

SWITCH REMOVAL AND REPLACEMENT *(continued)*

FIGURE F.20 – SWITCH

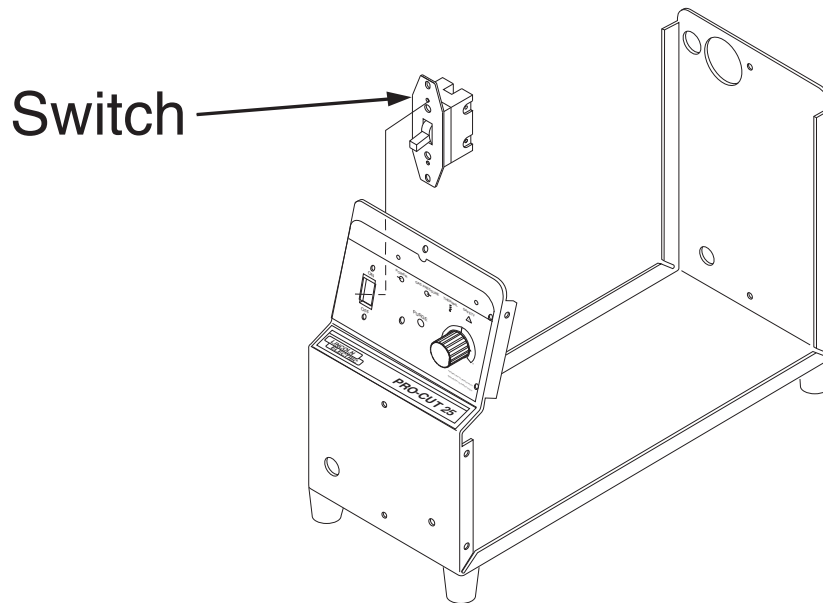

PROCEDURE

1. Remove input power to **PRO-CUT® 25**.
2. Remove carrying handle using a 4mm allen wrench.
3. Using a crescent wrench, carefully remove the plastic nut from around the pressure regulator located on the top of the machine.
4. Using a 7mm nut driver, remove the case wrap-around.
5. Perform ***Input Filter Capacitor Discharge Procedure***.
6. Using a phillips head screwdriver, remove the two power switch mounting screws located directly above and below the power switch.
7. Carefully remove the power switch assembly from the front of the machine, making note of insulation positioning.
8. Carefully label and identify the four leads and their terminals before removing. These leads and their positions are not labeled for you, so be sure to label them accurately.
9. After labeling the four leads, remove them from the switch using a flathead screwdriver.
10. After replacement of the switch, reconnect the four leads making sure that the switch is oriented correctly and the insulation is positioned correctly.
11. Replace the case wraparound
12. Replace the plastic nut from around the pressure regulator. **Do Not Over Tighten.**
13. Replace the carry handle.

PRO-CUT® 25



FAN REMOVAL AND REPLACEMENT



WARNING

Service and repair should be performed by only Lincoln Electric factory trained personnel. Unauthorized repairs performed on this equipment may result in danger to the technician or machine operator and will invalidate your factory warranty. For your safety and to avoid electrical shock, please observe all safety notes and precautions detailed throughout this manual.

If for any reason you do not understand the test procedures or are unable to perform the test/repairs safely, contact the Lincoln Electric Service Department for electrical troubleshooting assistance before you proceed. Call 1-888-935-3877.

DESCRIPTION

The following procedure will aid the technician in removing the Fan for maintenance or replacement.

MATERIALS NEEDED

- 4mm Allen Wrench
- Crescent Wrench
- 7mm Nut Driver
- Phillips Head Screwdriver

PRO-CUT® 25



FAN REMOVAL AND REPLACEMENT (continued)

PROCEDURE

1. Remove input power to **PRO-CUT® 25**.
2. Remove carrying handle using a 4mm allen wrench.
3. Using a crescent wrench, carefully remove the plastic nut from around the pressure regulator located on the top of the machine.
4. Using a 7mm nut driver, remove the case wraparound.
5. Perform **Input Filter Capacitor Discharge Procedure**.
6. Label and remove the two leads connected to the top of the fan. Be sure to correctly label these leads and note their positions.

FIGURE F.21 – FAN LOCATION

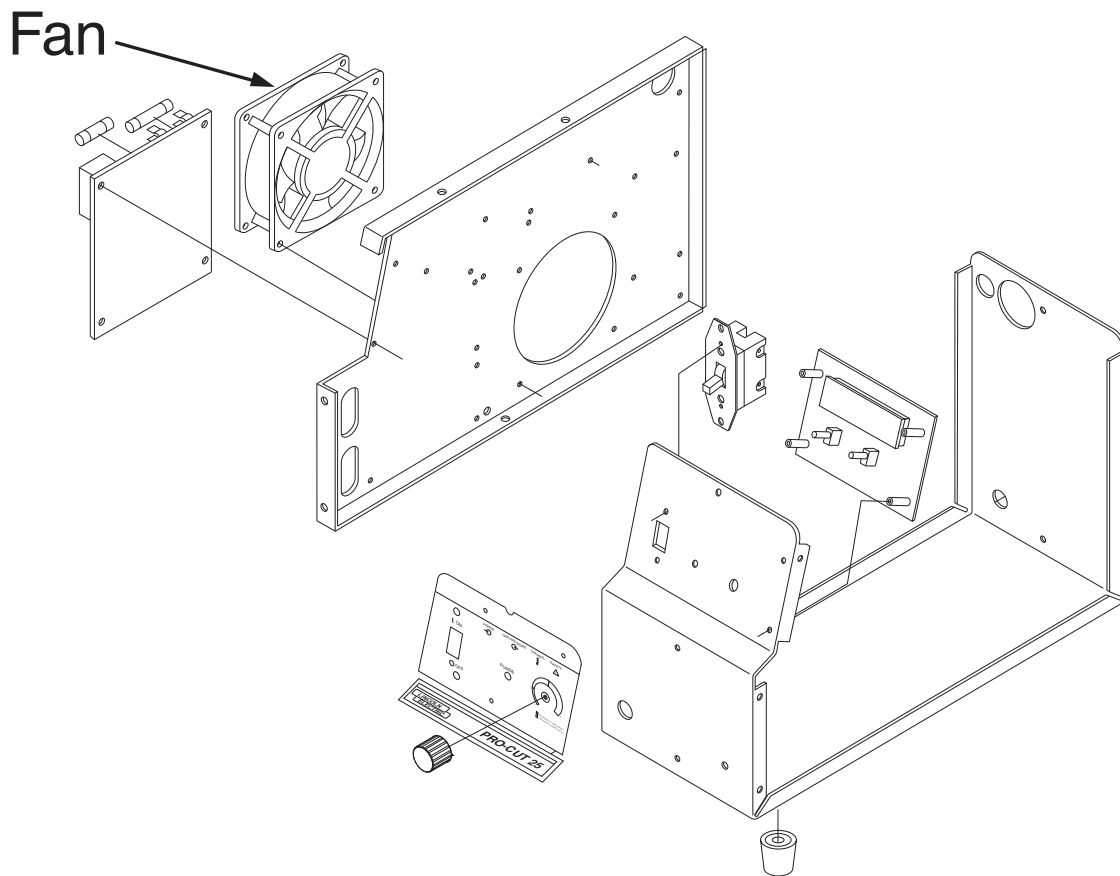

PRO-CUT® 25

LINCOLN
ELECTRIC

FAN REMOVAL AND REPLACEMENT *(continued)*

7. Using a phillips head screwdriver, remove the four mounting screws on the four corners of the fan. The fan will become free.
8. After replacement of the fan, replace the four mounting screws located at the corners of the fan.
9. Reconnect labeled leads to the top of the fan. Be sure to replace leads in their proper positions.
10. Replace the case wraparound.
11. Replace the plastic nut from around the pressure regulator. **Do Not Over Tighten.**
12. Replace the carry handle.

Return to Section TOC
Return to Master TOC

Return to Section TOC
Return to Master TOC

Return to Section TOC
Return to Master TOC

Return to Section TOC
Return to Master TOC

PRO-CUT® 25



RETEST AFTER REPAIR

Should a machine under test be rejected for any reason requiring the removal of any mechanical part that could affect the machine's electrical characteristics, or if any electrical components are repaired or replaced, the machine must be retested.

Machine Input and Output

Input Volts/Hertz	Input Current	Rated Output
230/1/60HZ	15 Amps	20A @ 100% Duty Cycle

Output Current Range	12 - 25 Amps
----------------------	--------------

Maximum Open Circuit Voltage	400 Volts
------------------------------	-----------

Pilot Current	12 amps
---------------	---------

Functional Test

1. Connect the machine to 230VAC and an air supply (70psi minimum).
2. Turn on the machine and verify the following:
 - When the machine is turned on the Thermal LED turns on for approximately 1 second.
 - The fan is functional.
 - The power LED is lit.
3. Test the pressure switch in the following way:
 - Press and hold the Purge button on the front of the machine. Using the regulator on the machine, slowly lower the air pressure and verify that the gas pressure LED turns on at approximately 35 to 40 psi.
 - With the gas pressure LED on, release the Purge button and then pull the trigger on the torch. Verify that a pilot arc does NOT occur. Release the trigger.
 - While again pressing the Purge button, slowly increase the air pressure using the regulator on the machine until the gas pressure LED turns off. Verify that the LED turns off at approximately 40-45 psi.
 - Continue to press the Purge button and set the air pressure at 65psi. Release the Purge button.
4. Test the Purge button safety function by again pressing the Purge button and then pulling the trigger on the torch. Verify that a pilot arc does NOT occur. Release the trigger and the Purge button. (This is not a repeat of the previous step, in this step the Purge button is pressed and the gas pressure LED is off.)
5. With no air flowing (postflow), pull the trigger on the torch. Verify that the air flows for 2 seconds (preflow) and then the pilot arc is initiated. While continuing to hold the trigger, verify that the pilot arc remains lit for 3 seconds then turns off automatically. Release the trigger and verify that the air continues to flow for 10 seconds (postflow).
6. Remove the shield cup from the torch and verify that the safety LED turns on. Re-tighten the shield cup on the torch and verify that the safety LED remains lit. Pull the trigger of the torch and verify that a pilot arc does NOT occur. Turn the machine off and then back on to clear the safety error.
7. Turn the **PRO-CUT® 25** off.

ELECTRICAL DIAGRAMS

TABLE OF CONTENTS -ELECTRICAL DIAGRAMS SECTION-

ELECTRICAL DIAGRAMS SECTION G

WIRING DIAGRAM - PROCUT 25 G-2

WIRING DIAGRAM W/ADDITIONAL INFO - PROCUT 25 G-3

SCHEMATIC - CONTROL PRINTED CIRCUIT BOARD - SHEET 1 G-4

SCHEMATIC - CONTROL PRINTED CIRCUIT BOARD - SHEET 2 G-5

SCHEMATIC - CONTROL PRINTED CIRCUIT BOARD - SHEET 3 G-6

PC BOARD ASSEMBLY - MAIN INVERTER BOARD G-7

PC BOARD ASSEMBLY - INPUT BOARD G-8

PC 25 TORCH DETAILS G-9

Return to Master TOC

Return to Master TOC

Return to Master TOC

Return to Master TOC

WIRING DIAGRAM - PRO-CUT® 25

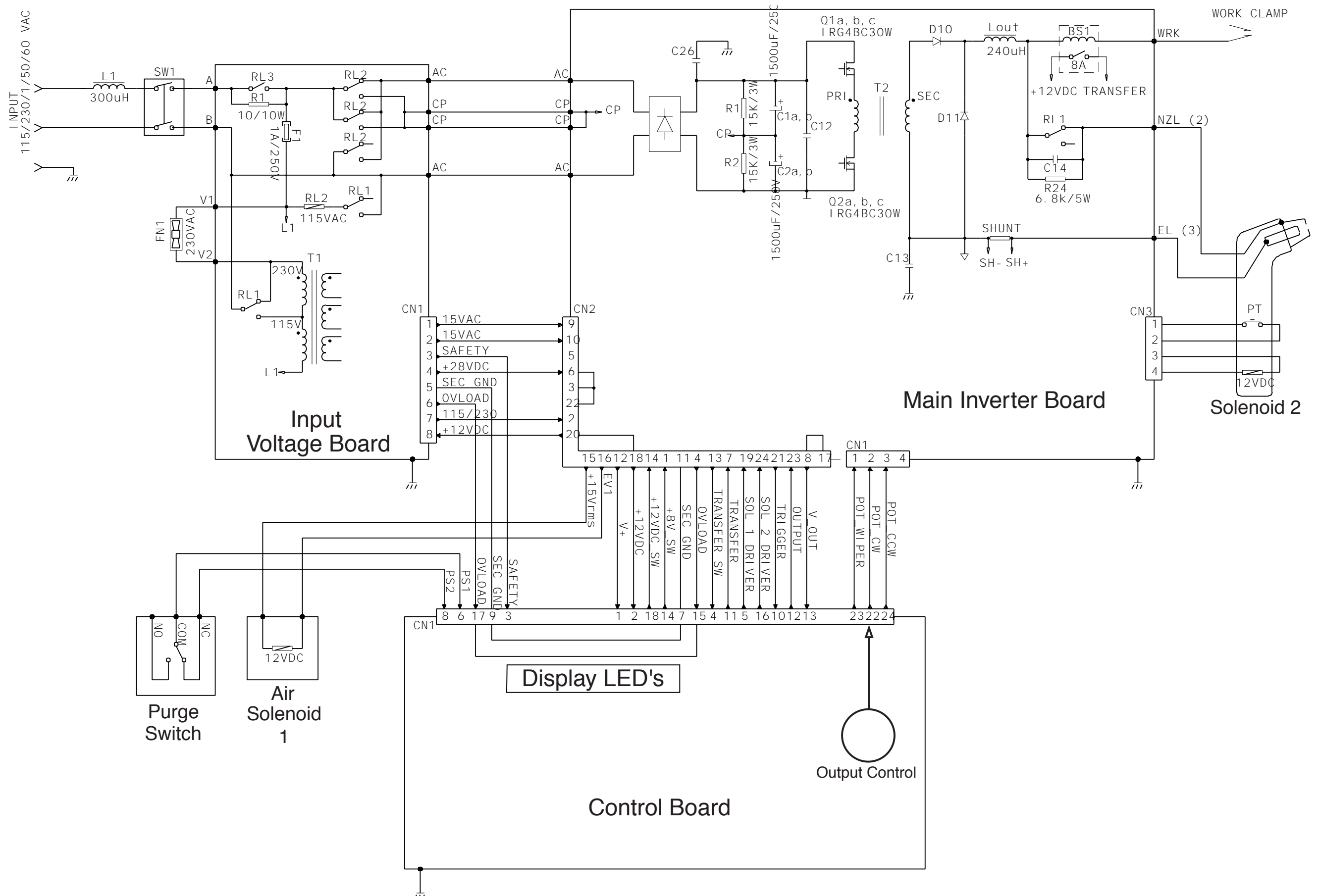

NOTE: This diagram is for reference only. It may not be accurate for all machines covered by this manual. The wiring diagram specific to your code is pasted inside one of the enclosure panels of your machine.



Return to Section TOC (repeated vertically on the left margin)

WIRING DIAGRAM W/ADDITIONAL INFO

Return to Section TOC
Return to Master TOC

Typical input current draw:
115v 25A/35% = 37.7A
20A/60% = 26.7A
230v 25A/60% = 19A
20A/100%=15A

Auto Reconnect Feature

*does it work in the other input voltage 115v or 230 v? If it does, it is an input bd.

Must be within +/- 10% of input. Must be greater than 208v.

YES for Ranger 250 series Commander 300, 400 ,500's

50hz /60 hz RPM's 2700/ 3100 amps .13/ .12 runs all the time

Pcb. card Represents: board soldered to a mother bd.

relay Represents: relay soldered to a mother bd.

PRO CUT 25

operating freq. 63 khz / 100khz (PC 25) / (PC20)

All thermo devices are on this inverter board

Reed switch (BS1) closes when cutting current is drawn

file: procut25.pp 3-11-02 3-6-03 3-20-02

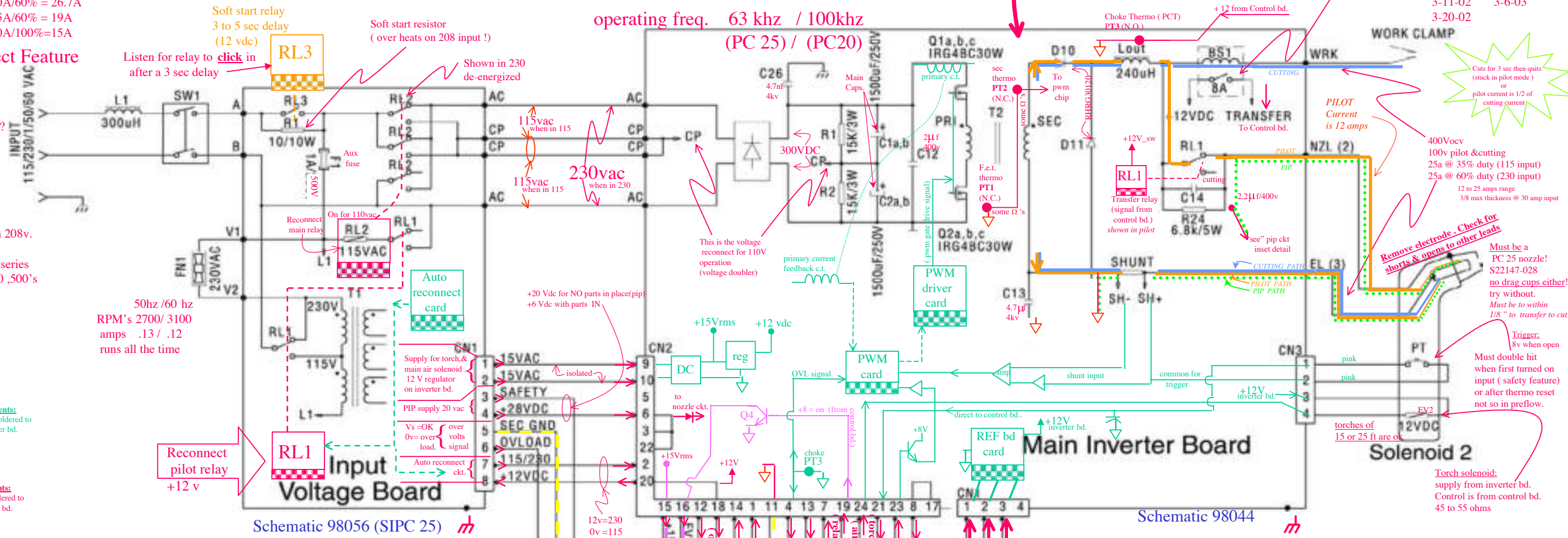

Schematic 98056 (SIPC 25)

Schematic 98044

Set air pressure while in purge to 65 psi.

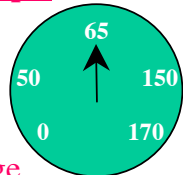

Air Guage

Supply pressure must be: 80 to 150 psi with a flow rate of no less than 4.0 cfm(113 l/min.) 240 cfm

pressure Switch

Closes @ 43.5 psi (3bars) Opens @ 37.7 to 42 psi (2.6 to 2.9 bars)

all LED's come on initially then just the POWER led is lit THERMO led stays lit for approx 3 sec also at turn on.



Purge Switch (n.o.)

Output Control (control bd mounted)

Schematic 99016 (SPA25)

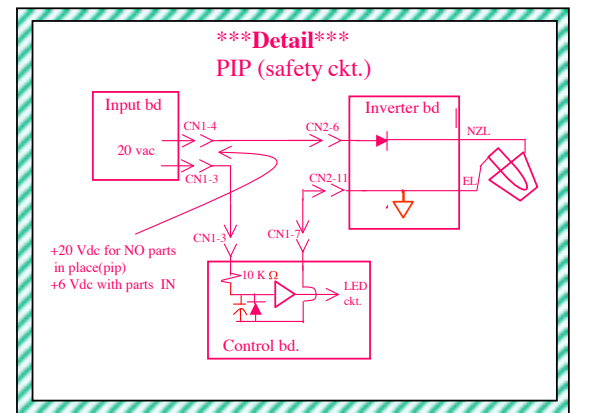

+12 VDC sw supply is used for: 1. Output control (control) & its ref. bd. (invert) 2. Shunt feedback (invert) 3. Transfer relay (invert & control) 4. Torch solenoid (inv & control) 5. LED supply

+8 VDC supply is used for: 1. Turn on PWM (invert) 2. PIP detect ckt.(control) 3. Pilot arc timer (control) 4. Purge ckt button(control) 5. Drivers for LED logic (control) 6. Torch solenoid logic ckt(control) 7. Air solenoid logic cks & driver (control) 8. Transfer relay (invert) Logic & driver(control)

NOTE: This diagram is for reference only. It may not be accurate for all machines covered by this manual.

SCHEMATIC- CONTROL PRINTED CIRCUIT BOARD - SHEET 1

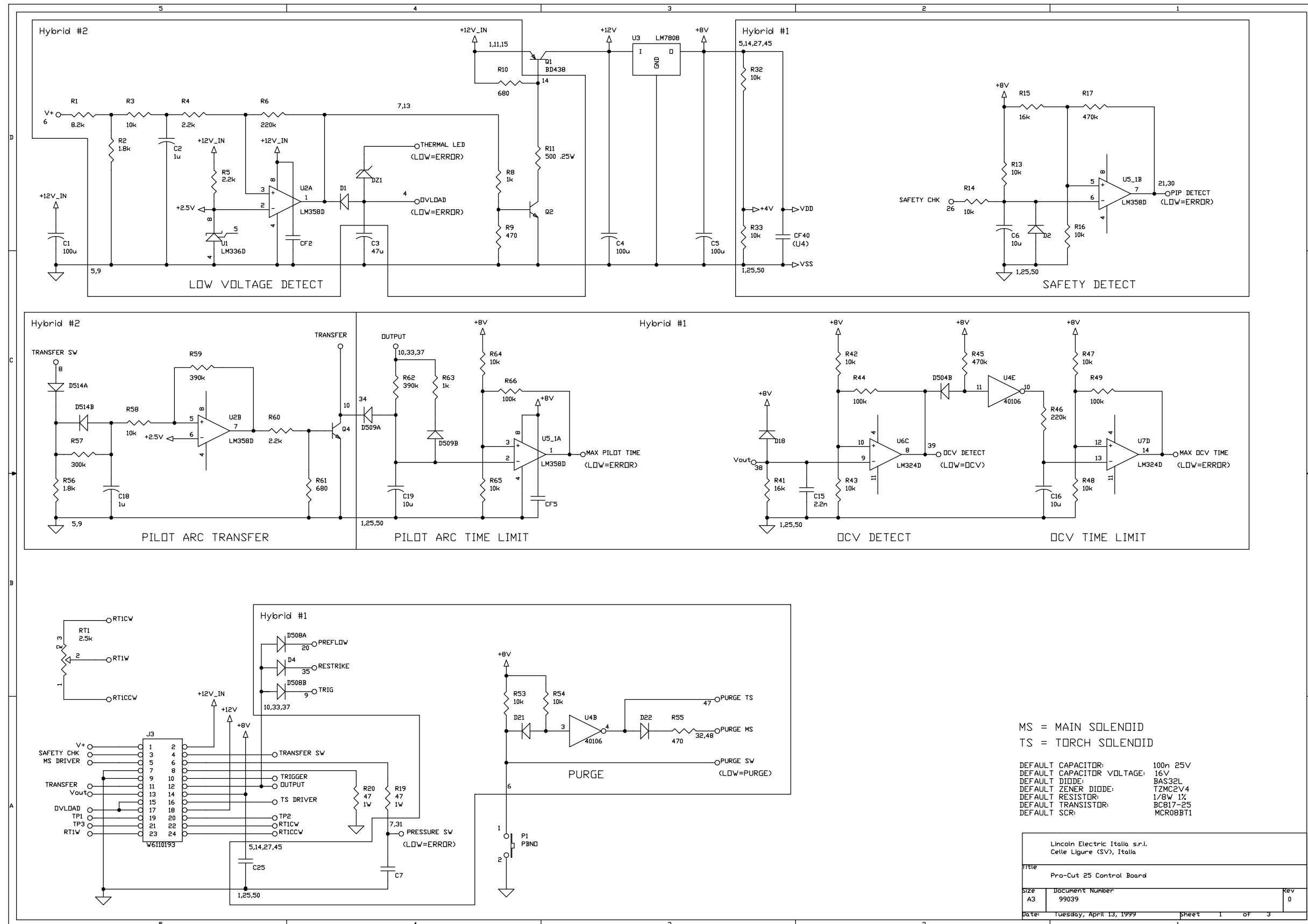

NOTE: This diagram is for reference only. It may not be accurate for all machines covered by this manual.

SCHEMATIC- CONTROL PRINTED CIRCUIT BOARD - SHEET 2

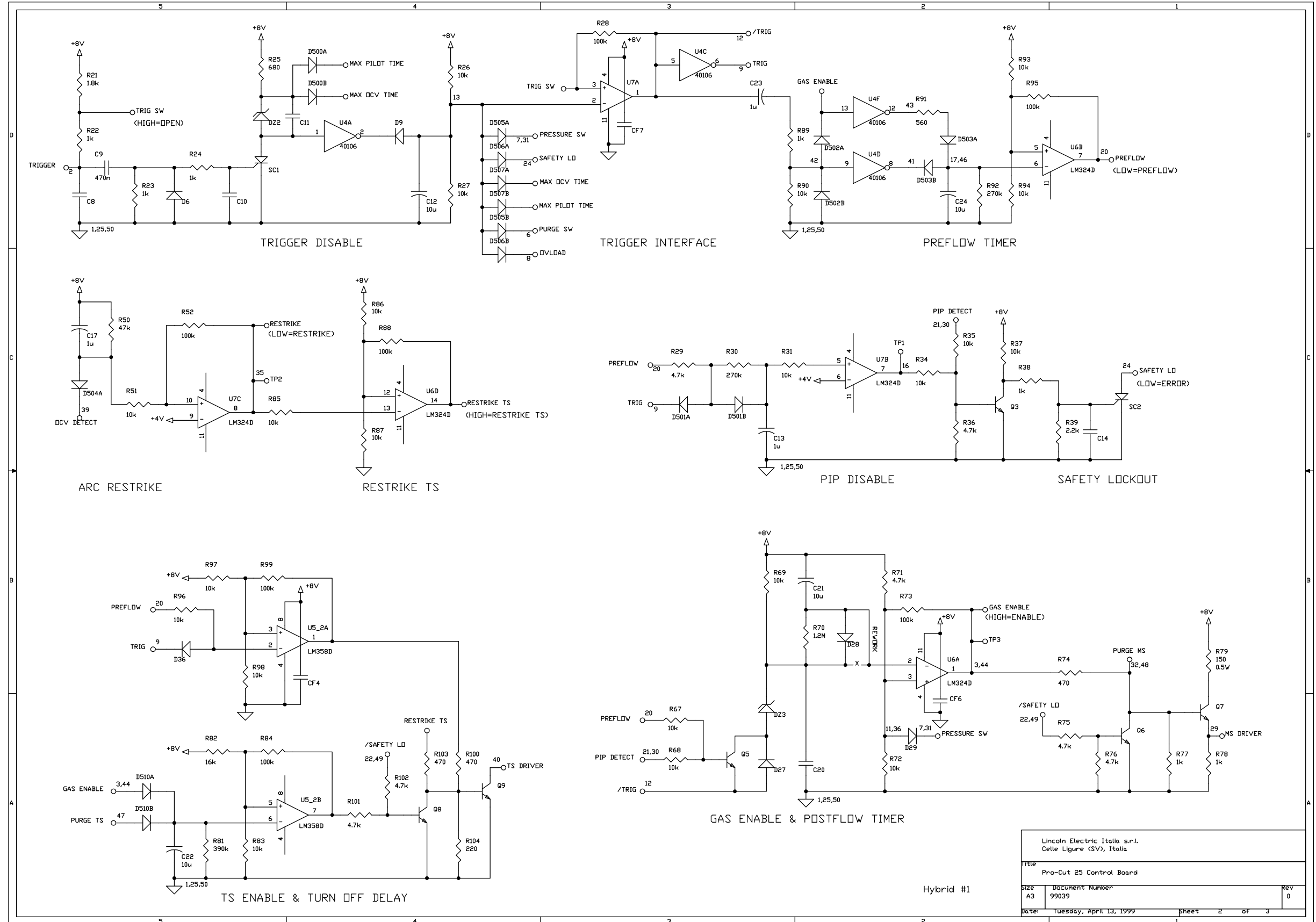

Lincoln Electric Italia s.r.l. Celle Ligure (SV), Italia	
Title Pro-Cut 25 Control Board	
Size A3	Document Number 99039
Date Tuesday, April 13, 1999	Sheet 2 of 3

NOTE: This diagram is for reference only. It may not be accurate for all machines covered by this manual.

Return to Section TOC

Return to Section TOC

Return to Section TOC

Return to Section TOC

Return to Master TOC

Return to Master TOC

Return to Master TOC

Return to Master TOC

PC BOARD ASSEMBLY - MAIN INVERTER BOARD

Return to Section TOC
Return to Master TOC

Return to Section TOC
Return to Master TOC

Return to Section TOC
Return to Master TOC

Return to Section TOC
Return to Master TOC

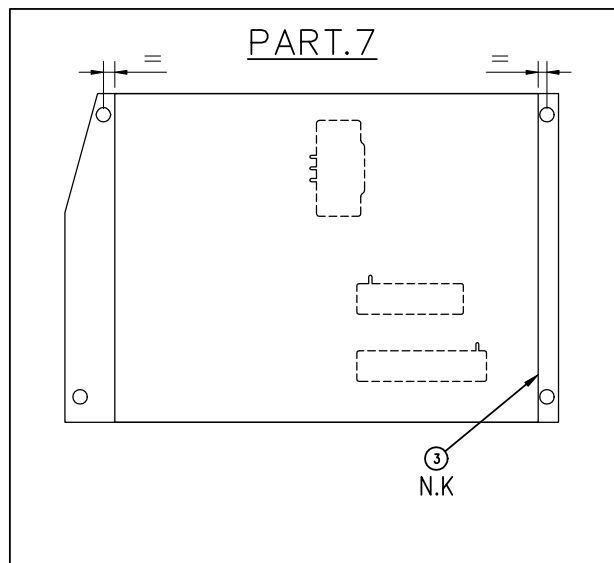
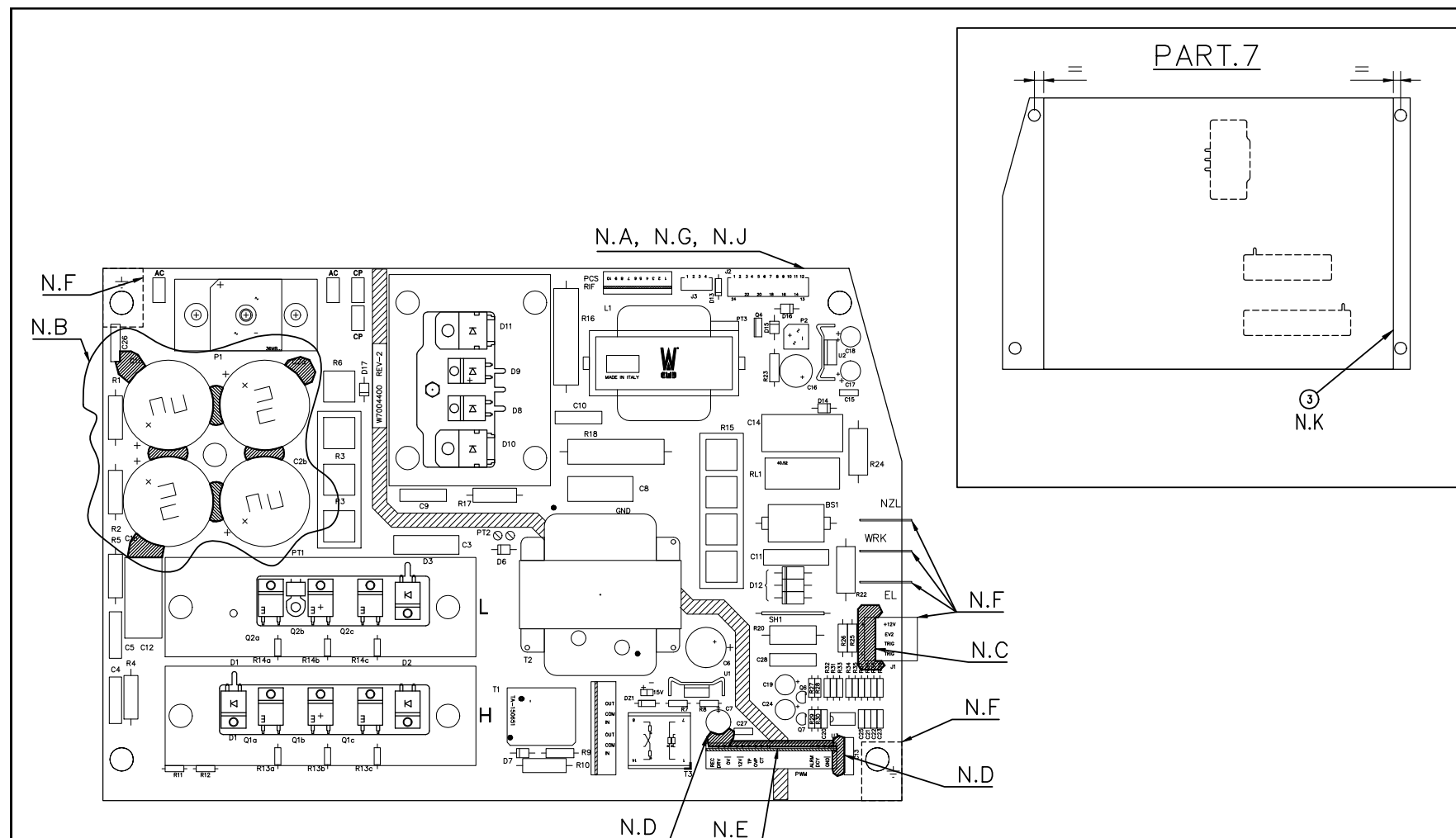

RIF.	Codice	Descrizione	Q.tà
1	W7900006	SIGILLANTE SILICONICO	Q.B.
2	W7900010	VERNICE ISOLANTE 220	Q.B.
3	W0799084	ADESIVO PER INVERTER	1

SPECIFICHE DI COLLAUDO: PC-006

N.A - ESEGUIRE LE PROCEDURE DI COLLAUDO PC-006.
 N.B - APPLICARE SILICONE (RIF.1) INTORNO AI CONDENSATORI COME INDICATO PER UN'ALTEZZA DI 1cm.
 N.C - APPLICARE SILICONE (RIF.1) SUI PIN DEL CONNETTORE J1 COPRENDOLI COMPLETAMENTE (PART.1).
 N.D - APPLICARE SILICONE (RIF.1) TRA LA SCHEDA PWM E I CONDENSATORI C7 E C13 COME INDICATO PER UN'ALTEZZA DI 2cm.
 N.E - APPLICARE SILICONE (RIF.1) TRA LA SCHEDA PWM E LA SCHEDA INVERTER PER UN'ALTEZZA DI 0.5cm.
 N.F - ISOLARE I FASTON INDICATI (EL, WRK E NZL), IL CONNETTORE J1 E LE 2 PIZZOLE DI TERRA CON NASTRO ADESIVO COME INDICATO NEI PART.1-2-3.
 N.G - VERNICIARE (RIF.2) LA SCHEDA PER IMMERSIONE (VEDERE PROCEDURA RT-008) PRESTANDO PARTICOLARE ATTENZIONE AFFINCHÉ IL LIVELLO DELLA VERNICE CORRISPONDA A QUANTO INDICATO IN PART.4.
 N.H - APPENDERE LA SCHEDA IN POSIZIONE VERTICALE (VEDERE PART.5) FINO A QUANDO SMETTE DI GOCCIOLARE.
 N.I - APPENDERE LA SCHEDA IN POSIZIONE INCLINATA (VEDERE PART.6) FINO A QUANDO RISULTA ASCIUTTA AL TATTO.
 N.J - LASCIARE ASCIUGARE LA SCHEDA PER 24 ORE DALLA VERNICIATURA DOPODICHE' FARE IL TEST DIELETTRICO.
 N.K - APPLICARE L'ADESIVO (RIF.3) SUL LATO SALDATURE COME INDICATO IN PART.7.

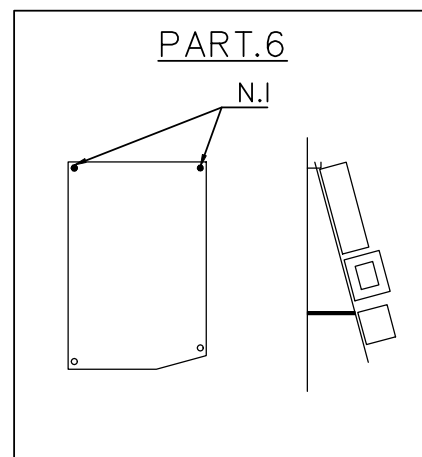
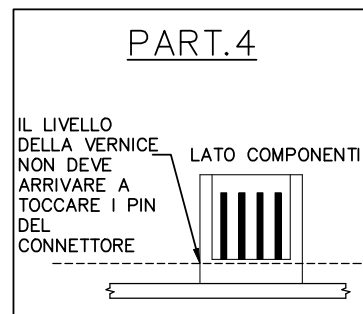
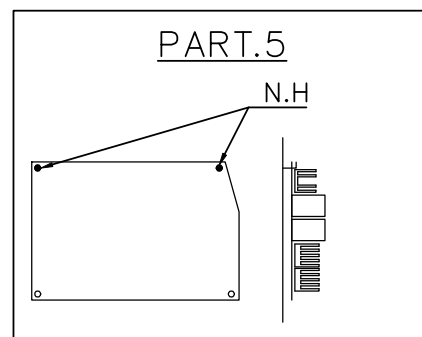
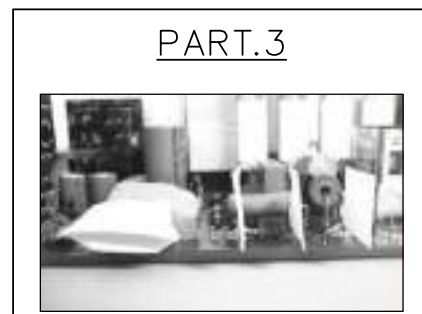
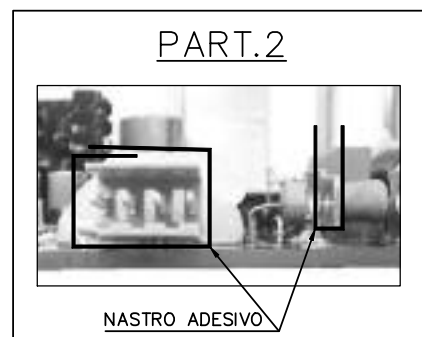

FASE 2 PAG. 2/2

TOLLERANZE ±0,2 SALVO GIÀ DOVE ESPRESSAMENTE INDICATO È VIETATA LA DIVULGAZIONE NON AUTORIZZATA DEL PRESENTE DOCUMENTO.

This sheet contains proprietary information owned by LINCOLN ELECTRIC ITALIA S.R.L. and is not to be reproduced, disclosed, or used without the express permission of LINCOLN ELECTRIC ITALIA S.R.L.

02	28012000D	FDM	LINCOLN ELECTRIC ITALIA s.r.l. CELLE LIGURE (SV), ITALIA	ASSEMBLAGGIO COMPONENTI INVERTER PC-25
01	100699C	FDM		
REV.	DATA	VISTO	SCALA : _____ DATA 17/02/1999	NUMERO DI DISEGNO
			DISEGN. FDM/CD	APPR. _____

W0504400

NOTE: Lincoln Electric assumes no responsibility for liabilities resulting from board level troubleshooting. PC Board repairs will invalidate your factory warranty. **Individual Printed Circuit Board Components are not available from Lincoln Electric.** This information is provided for reference only. Lincoln Electric discourages board level troubleshooting and repair since it may compromise the quality of the design and may result in danger to the Machine Operator or Technician. Improper PC board repairs could result in damage to the machine.

PC BOARD ASSEMBLY - INPUT BOARD

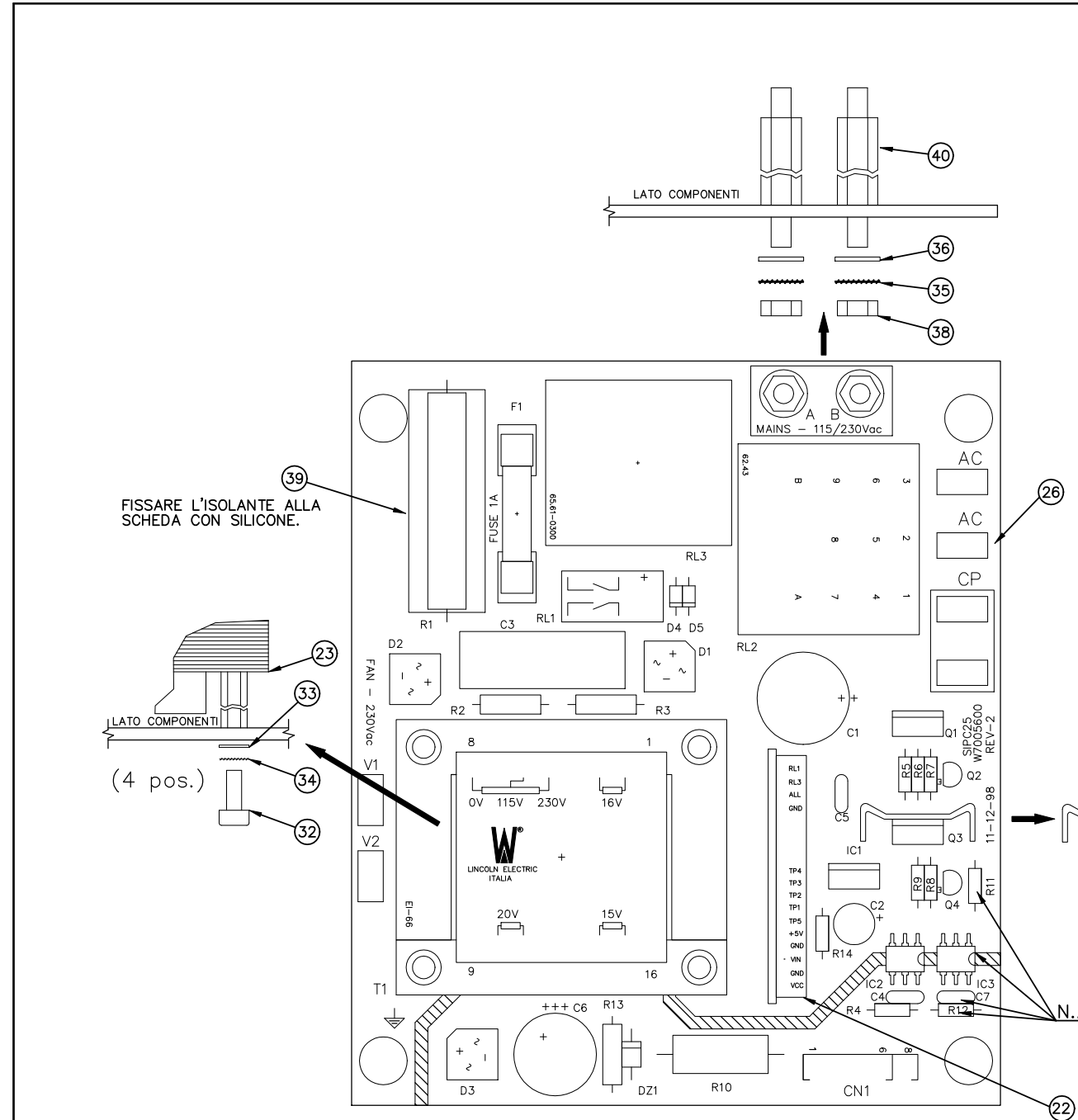

RIF.	Codice	Descrizione	Rif. topografico	Qtà
1	W1020056	RES. 5.6 OHM 0.25W 5%	R9	1
2	W1020150	RES. 15 OHM 0.25W 5%	R7	1
3	W1021470	RES. 470 OHM 0.25W 5%	R5-R6-R8	3
4	W1024470	RES. 470K OHM 0.25W 5%	R4	1
5	W1124330	RES. 330K OHM 0.5W 5%	R2-R3	2
6	W1221470	RES. 47 OHM 1W 5%	R13	1
7	W1521180	RES. 180 OHM 5W 5%	R10	1
8	W1701040	RES. 10 OHM 10W 10%	R1	1
9	W3042470	COND.CER.4700pF 100V X7R 10%	C4	1
10	W3043105	COND. CER. 0,1uF 50V P=5.08 10%	C5	1
11	W3083470	COND.BOX 470nF 630V 10%	C3	1
12	W3410220	COND.EL.RAD. 220uF 100V 20%	C6	1
13	W3416472	COND.EL.RAD. 220uF 25V 20%	C2	1
14	W3435150	COND.EL.RAD. 1500uF 35V 20%	C1	1
15	W4004148	DIODO 1N4148	D4-D5	2
16	W411000E	PONTE 1KAB100E 1.5A 1KV	D1-D2-D3	3
17	W4207907	DIODO ZENER 5.1V 1W	DZ1	1
18	W4300184	TRANS. NPN TO-92 BC-184	Q2-Q4	2
19	W4304408	TRANSISTOR NPN D44H8	Q1-Q3	2
20	W450062A	OPTOISOLATORE CNY17-3	IC2	1
21	W4607805	INTEGRATO 7805 1A 5V	IC1	1
22	W05338A1	SCHEDA CSI-20U (logica)		1
23	W5998057	TRASFORMATORE AUSILIARIO	T1	1
24	W6000009	FASTON MASCHIO PER C.S.	V1-V2-AC-AC-CP	6
25	W6110108	CONNETTORE MODU2 8X1 AMP	CN1	1
26	W7005600	CIRC. STAMP. SIPC25	REV.02	1
27	W7130220	RELE' 2 SCAMBI 2A 6Vdc	RL1	1
28	W7162430	RELE' 3 SCAMBI 16A 110V	RL2	1
29	W7165610	RELE'1 N.O 30A 12Vdc x C.S	RL3	1
30	W7301000	FUSIBILE RITARDATO 1A	F1	1
31	W7900630	PINZA PER FUSIBILE	PF1-PF2	2
32	W8093008	VITE ACCIAIO ZINC. M3x8 T.C.C		5
33	W8100003	RONDELLA PIANA M3 ACCIAIO		5
34	W8110003	RONDELLA DENTATA INT. M3		5
35	W8110004	RONDELLA DENTATA INT. M4		2
36	W8111004	RONDELLA PIANA M4 OTTONE		2
37	W8200003	DADO ACCIAIO ZINCATO M3		1
38	W8210004	DADO OTTONE M4		2
39	W84A4355	ISOLANTE ISOLCART		1
40	W86A4406	TORRETTA M4x8 M/M OTTONE	A-B	2
41	W9108165	DISSIPATORE TRANS. TO220		1
42	W1020100	RESISTENZA 10 OHM 0.25W 5%	R14	1

SPECIFICHE DI COLLAUDO: PC-003
 SCHEMA ELETTRICO: 98056rev4

N.A - NON MONTARE I SEGUENTI COMPONENTI:
 R11, R12, IC3, C7

FASE 1	PAG. 1/2
TOLLERANZE ±0,2 SALVO GIÀ DOVE ESPRESSAMENTE INDICATO È VIETATA LA DIVULGAZIONE NON AUTORIZZATA DEL PRESENTE DOCUMENTO. This sheet contains proprietary information owned by LINCOLN ELECTRIC ITALIA S.R.L. and is not to be reproduced, disclosed, or used without the express permission of LINCOLN ELECTRIC ITALIA S.R.L.	
LINCOLN ELECTRIC ITALIA s.r.l. CELLE LIGURE (SV), ITALIA	LAVORAZIONI SCHEDA SIPC25
SCALA _____ DATA 02/12/98 DISEGN. C.D. _____ APPR. _____	NUMERO DI DISEGNO W0505600
01 090699A FDM REV. DATA VISTO	

NOTE: Lincoln Electric assumes no responsibility for liabilities resulting from board level troubleshooting. PC Board repairs will invalidate your factory warranty. **Individual Printed Circuit Board Components are not available from Lincoln Electric.** This information is provided for reference only. Lincoln Electric discourages board level troubleshooting and repair since it may compromise the quality of the design and may result in danger to the Machine Operator or Technician. Improper PC board repairs could result in damage to the machine.



Return to Section TOC

PC 25 TORCH DETAILS

Return to Section TOC
Return to Master TOC
Return to Section TOC
Return to Master TOC
Return to Section TOC
Return to Master TOC
Return to Section TOC
Return to Master TOC

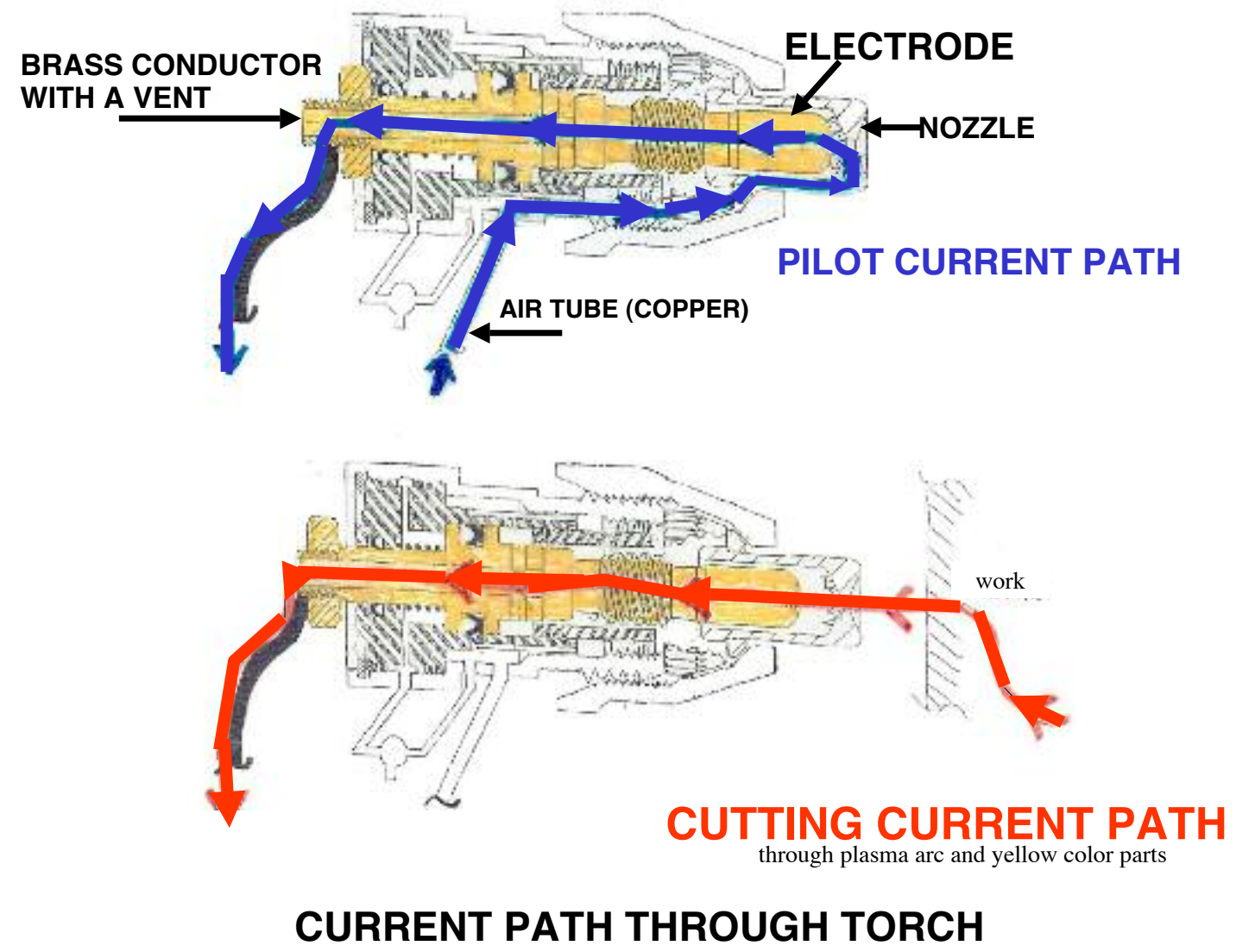
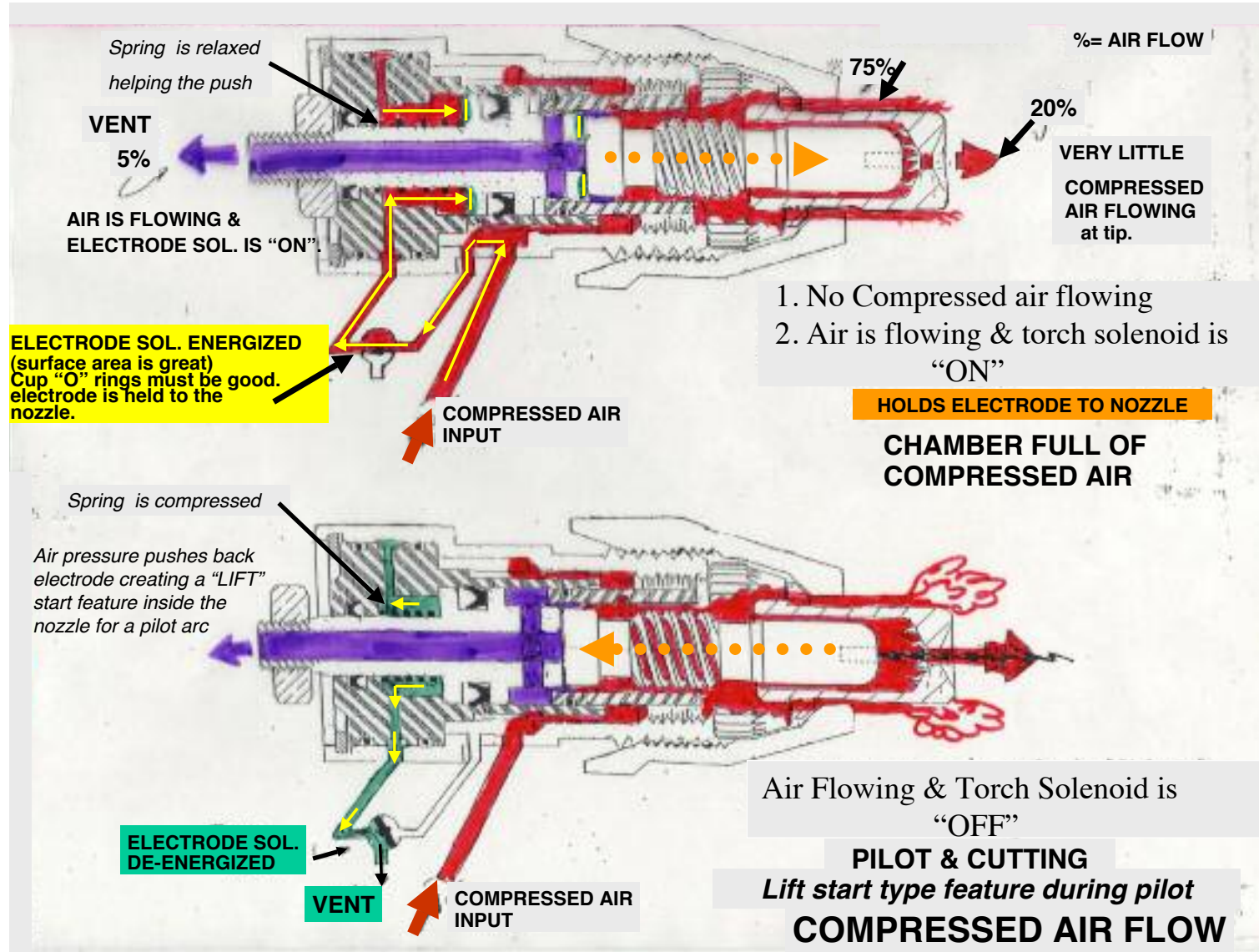

NOTE: This diagram is for reference only. It may not be accurate for all machines covered by this manual.