

BEFORE YOU CUT - refer to <http://www.lincolnelectric.com/safety> for additional safety information.

1 Verify Input and Output Connections

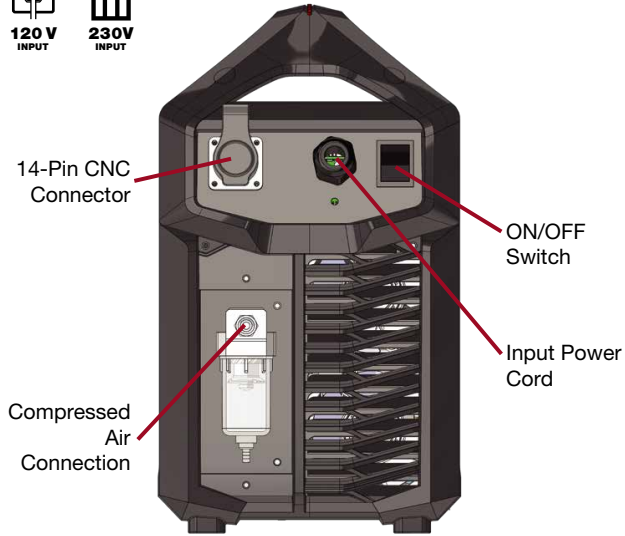

2 Turning Machine ON and Adjusting Parameters

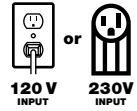
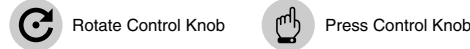

Startup Screen



Home Screen

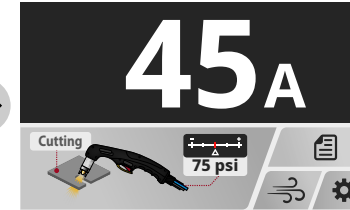

Rotate to Adjust Current

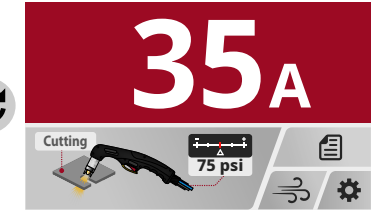

Home Screen

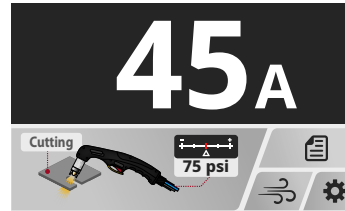

Press to Select Setting

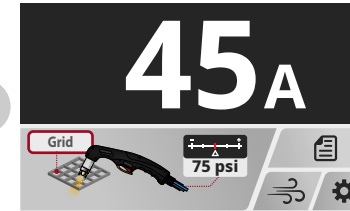

Press & Rotate to Adjust Process
Press Again to Finalize Selection

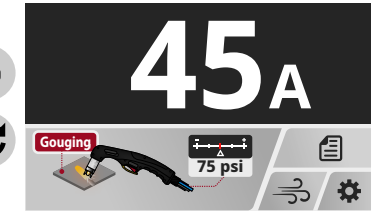

Home Screen

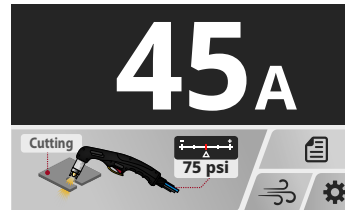

Press to Select Setting
Rotate to Pressure Selection

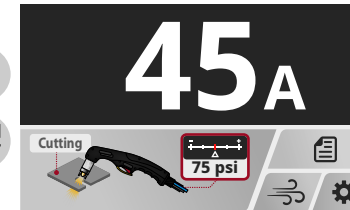

Press & Rotate to Adjust Pressure
Press Again to Finalize Selection

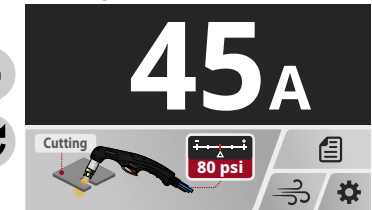

3 Explanation of Icons

Cutting Guide – Select Cutting Material and Thickness for a Recommended Output Amperage

Air Purge – Select to Allow Compressed Air to Flow Through the Torch

Advanced Settings – Select Trigger Control, Language, & Measurement Units

4

Advanced Settings Menu

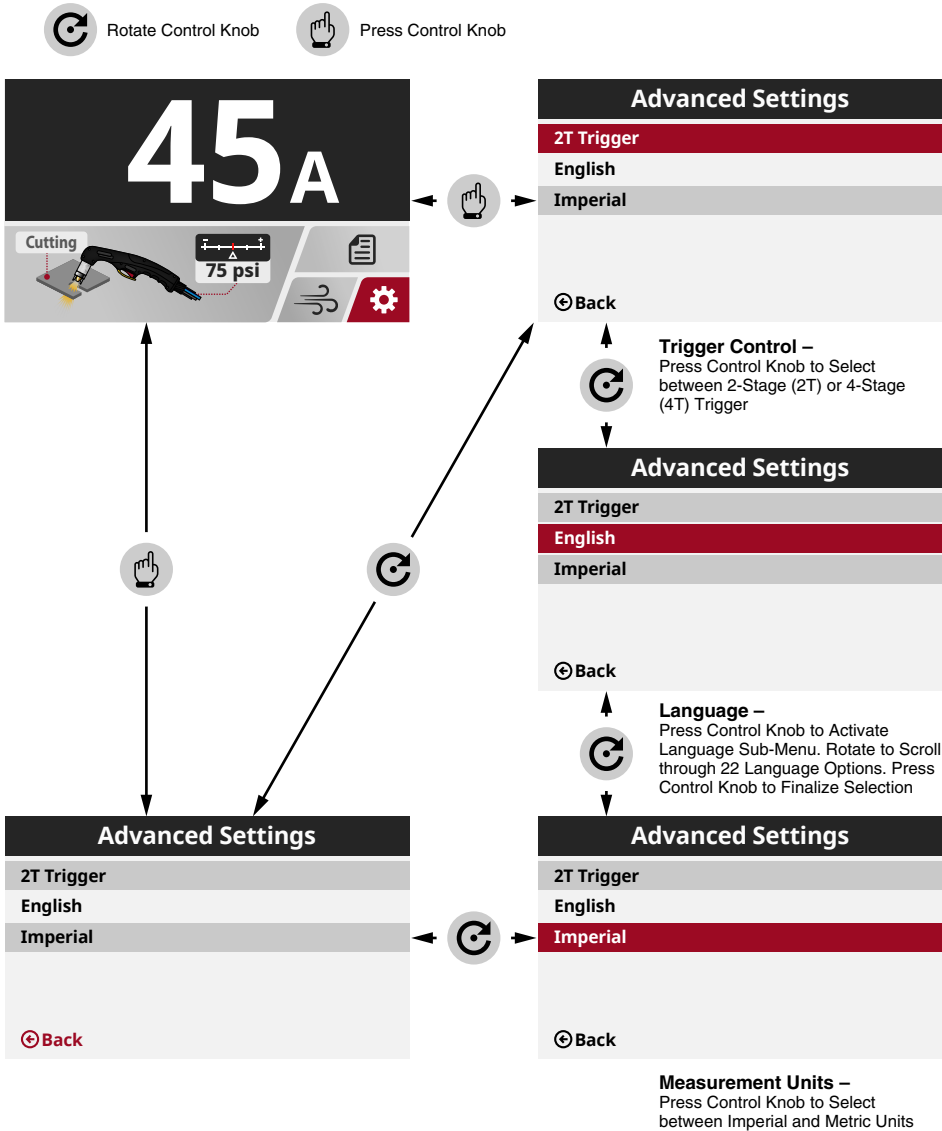

5

Torch Assembly

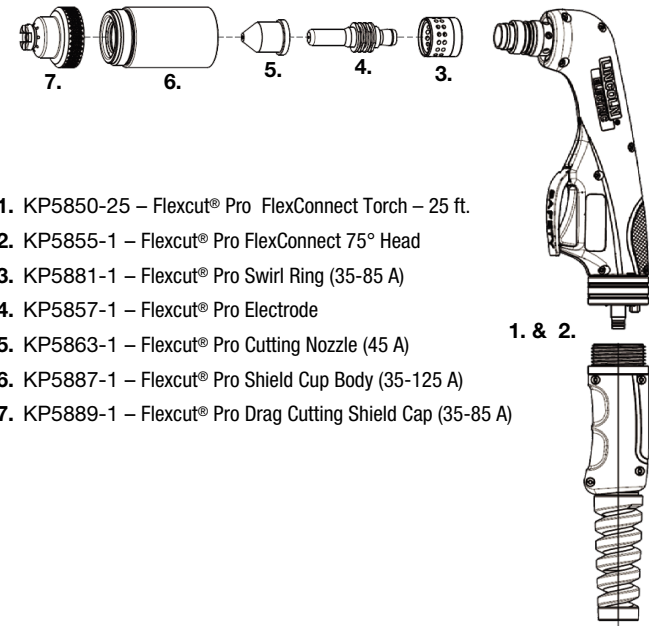

1. KP5850-25 – Flexcut® Pro FlexConnect Torch – 25 ft.
2. KP5855-1 – Flexcut® Pro FlexConnect 75° Head
3. KP5881-1 – Flexcut® Pro Swirl Ring (35-85 A)
4. KP5857-1 – Flexcut® Pro Electrode
5. KP5863-1 – Flexcut® Pro Cutting Nozzle (45 A)
6. KP5887-1 – Flexcut® Pro Shield Cup Body (35-125 A)
7. KP5889-1 – Flexcut® Pro Drag Cutting Shield Cap (35-85 A)

6

Cutting Techniques

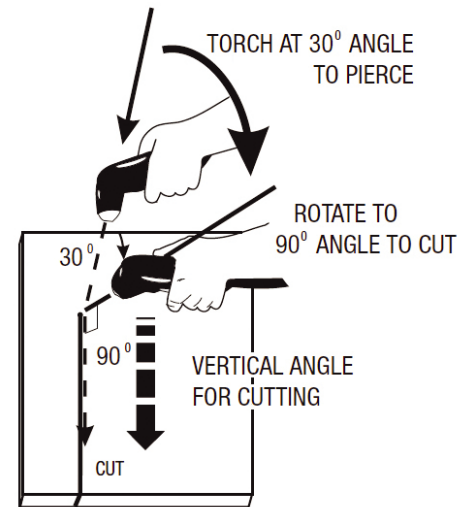

- Pierce the work piece by slowly lowering the torch onto the metal at a 30° angle away from the operator. This will blow the dross away from the torch tip. Slowly rotate the torch to vertical position as the arc becomes deeper.
- Keep moving while cutting. Cut at a steady speed without pausing. Maintain the cutting speed so that the arc lag is 10° to 20° behind the travel direction.
- Use a 5° - 15° leading angle in the direction of the cut.
- Finish the cut to be made and release the trigger.
- If the dross is difficult to remove, reduce the cutting speed. High speed dross is more difficult to remove than low speed dross.
- The Post Flow time is 20 seconds