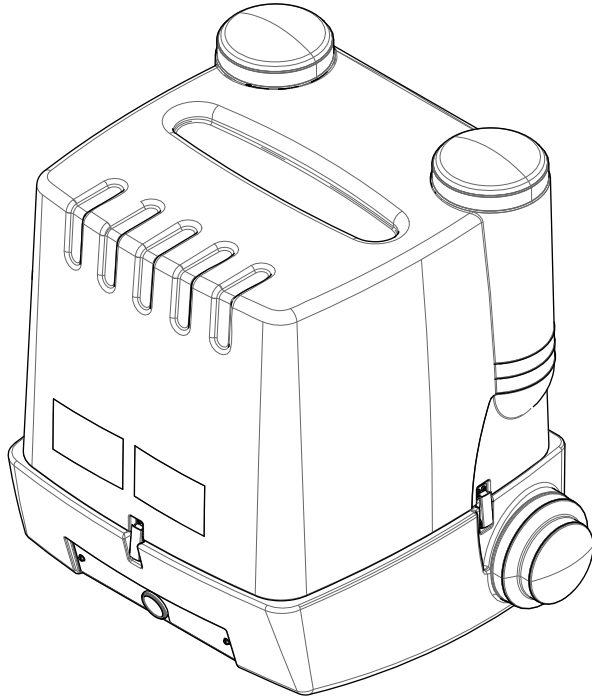


## Operator's Manual

# Statiflex<sup>®</sup> 200-M



For use with machines having Product Numbers:

**K1654-4 - Single Arm Base Unit**

**K1654-5 - Dual Arm Base Unit**

**K1654-6 - High Efficiency Single Arm Base Unit**



**Register your machine:**

[www.lincolnelectric.com/register](http://www.lincolnelectric.com/register)

**Authorized Service and Distributor Locator:**

[www.lincolnelectric.com/locator](http://www.lincolnelectric.com/locator)

**Save for future reference**

Date Purchased

Code: (ex: 10859)

Serial: (ex: U1060512345)

**Need Help? Call 1.888.935.3877**

to talk to a Service Representative

**Hours of Operation:**

8:00 AM to 6:00 PM (ET) Mon. thru Fri.

**After hours?**

Use "Ask the Experts" at [lincolnelectric.com](http://lincolnelectric.com)  
A Lincoln Service Representative will contact you no later than the following business day.

**For Service outside the USA:**

Email: [globalservice@lincolnelectric.com](mailto:globalservice@lincolnelectric.com)

# THANK YOU FOR SELECTING A QUALITY PRODUCT BY LINCOLN ELECTRIC.

## PLEASE EXAMINE CARTON AND EQUIPMENT FOR DAMAGE IMMEDIATELY

When this equipment is shipped, title passes to the purchaser upon receipt by the carrier. Consequently, claims for material damaged in shipment must be made by the purchaser against the transportation company at the time the shipment is received.

## SAFETY DEPENDS ON YOU

Lincoln arc welding and cutting equipment is designed and built with safety in mind. However, your overall safety can be increased by proper installation ... and thoughtful operation on your part. **DO NOT INSTALL, OPERATE OR REPAIR THIS EQUIPMENT WITHOUT READING THIS MANUAL AND THE SAFETY PRECAUTIONS CONTAINED THROUGHOUT.** And, most importantly, think before you act and be careful.

### **WARNING**

This statement appears where the information must be followed exactly to avoid serious personal injury or loss of life.

### **CAUTION**

This statement appears where the information must be followed to avoid minor personal injury or damage to this equipment.



## KEEP YOUR HEAD OUT OF THE FUMES.

**DON'T** get too close to the arc. Use corrective lenses if necessary to stay a reasonable distance away from the arc.

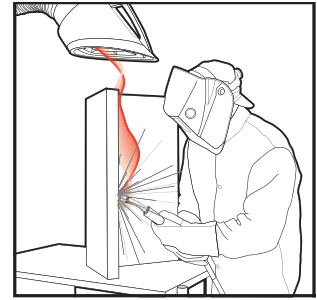
**READ** and obey the Safety Data Sheet (SDS) and the warning label that appears on all containers of welding materials.

**USE ENOUGH VENTILATION** or exhaust at the arc, or both, to keep the fumes and gases from your breathing zone and the general area.

**IN A LARGE ROOM OR OUTDOORS**, natural ventilation may be adequate if you keep your head out of the fumes (See below).

**USE NATURAL DRAFTS** or fans to keep the fumes away from your face.

If you develop unusual symptoms, see your supervisor. Perhaps the welding atmosphere and ventilation system should be checked.



## WEAR CORRECT EYE, EAR & BODY PROTECTION

**PROTECT** your eyes and face with welding helmet properly fitted and with proper grade of filter plate (See ANSI Z49.1).

**PROTECT** your body from welding spatter and arc flash with protective clothing including woolen clothing, flame-proof apron and gloves, leather leggings, and high boots.

**PROTECT** others from splatter, flash, and glare with protective screens or barriers.

**IN SOME AREAS**, protection from noise may be appropriate.

**BE SURE** protective equipment is in good condition.

Also, wear safety glasses in work area **AT ALL TIMES.**



## SPECIAL SITUATIONS

**DO NOT WELD OR CUT** containers or materials which previously had been in contact with hazardous substances unless they are properly cleaned. This is extremely dangerous.

**DO NOT WELD OR CUT** painted or plated parts unless special precautions with ventilation have been taken. They can release highly toxic fumes or gases.

## Additional precautionary measures

**PROTECT** compressed gas cylinders from excessive heat, mechanical shocks, and arcs; fasten cylinders so they cannot fall.

**BE SURE** cylinders are never grounded or part of an electrical circuit.

**REMOVE** all potential fire hazards from welding area.

**ALWAYS HAVE FIRE FIGHTING EQUIPMENT READY FOR IMMEDIATE USE AND KNOW HOW TO USE IT.**



## SECTION A: WARNINGS



### CALIFORNIA PROPOSITION 65 WARNINGS

#### Diesel Engines

Diesel engine exhaust and some of its constituents are known to the State of California to cause cancer, birth defects, and other reproductive harm.

#### Gasoline Engines

The engine exhaust from this product contains chemicals known to the State of California to cause cancer, birth defects, or other reproductive harm.

**ARC WELDING CAN BE HAZARDOUS. PROTECT YOURSELF AND OTHERS FROM POSSIBLE SERIOUS INJURY OR DEATH. KEEP CHILDREN AWAY. PACEMAKER WEARERS SHOULD CONSULT WITH THEIR DOCTOR BEFORE OPERATING.**

Read and understand the following safety highlights. For additional safety information, it is strongly recommended that you purchase a copy of "Safety in Welding & Cutting - ANSI Standard Z49.1" from the American Welding Society, P.O. Box 351040, Miami, Florida 33135 or CSA Standard W117.2-1974. A Free copy of "Arc Welding Safety" booklet E205 is available from the Lincoln Electric Company, 22801 St. Clair Avenue, Cleveland, Ohio 44117-1199.

**BE SURE THAT ALL INSTALLATION, OPERATION, MAINTENANCE AND REPAIR PROCEDURES ARE PERFORMED ONLY BY QUALIFIED INDIVIDUALS.**



### FOR ENGINE POWERED EQUIPMENT.

- 1.a. Turn the engine off before troubleshooting and maintenance work unless the maintenance work requires it to be running.



- 1.b. Operate engines in open, well-ventilated areas or vent the engine exhaust fumes outdoors.

- 1.c. Do not add the fuel near an open flame welding arc or when the engine is running. Stop the engine and allow it to cool before refueling to prevent spilled fuel from vaporizing on contact with hot engine parts and igniting. Do not spill fuel when filling tank. If fuel is spilled, wipe it up and do not start engine until fumes have been eliminated.



- 1.d. Keep all equipment safety guards, covers and devices in position and in good repair. Keep hands, hair, clothing and tools away from V-belts, gears, fans and all other moving parts when starting, operating or repairing equipment.



- 1.e. In some cases it may be necessary to remove safety guards to perform required maintenance. Remove guards only when necessary and replace them when the maintenance requiring their removal is complete. Always use the greatest care when working near moving parts.
- 1.f. Do not put your hands near the engine fan. Do not attempt to override the governor or idler by pushing on the throttle control rods while the engine is running.
- 1.g. To prevent accidentally starting gasoline engines while turning the engine or welding generator during maintenance work, disconnect the spark plug wires, distributor cap or magneto wire as appropriate.

- 1.h. To avoid scalding, do not remove the radiator pressure cap when the engine is hot.



### ELECTRIC AND MAGNETIC FIELDS MAY BE DANGEROUS



- 2.a. Electric current flowing through any conductor causes localized Electric and Magnetic Fields (EMF). Welding current creates EMF fields around welding cables and welding machines
- 2.b. EMF fields may interfere with some pacemakers, and welders having a pacemaker should consult their physician before welding.
- 2.c. Exposure to EMF fields in welding may have other health effects which are now not known.
- 2.d. All welders should use the following procedures in order to minimize exposure to EMF fields from the welding circuit:
- 2.d.1. Route the electrode and work cables together - Secure them with tape when possible.
  - 2.d.2. Never coil the electrode lead around your body.
  - 2.d.3. Do not place your body between the electrode and work cables. If the electrode cable is on your right side, the work cable should also be on your right side.
  - 2.d.4. Connect the work cable to the workpiece as close as possible to the area being welded.
  - 2.d.5. Do not work next to welding power source.



## ELECTRIC SHOCK CAN KILL.



- 3.a. The electrode and work (or ground) circuits are electrically “hot” when the welder is on. Do not touch these “hot” parts with your bare skin or wet clothing. Wear dry, hole-free gloves to insulate hands.
- 3.b. Insulate yourself from work and ground using dry insulation. Make certain the insulation is large enough to cover your full area of physical contact with work and ground.

**In addition to the normal safety precautions, if welding must be performed under electrically hazardous conditions (in damp locations or while wearing wet clothing; on metal structures such as floors, gratings or scaffolds; when in cramped positions such as sitting, kneeling or lying, if there is a high risk of unavoidable or accidental contact with the workpiece or ground) use the following equipment:**

- Semiautomatic DC Constant Voltage (Wire) Welder.
  - DC Manual (Stick) Welder.
  - AC Welder with Reduced Voltage Control.
- 3.c. In semiautomatic or automatic wire welding, the electrode, electrode reel, welding head, nozzle or semiautomatic welding gun are also electrically “hot”.
  - 3.d. Always be sure the work cable makes a good electrical connection with the metal being welded. The connection should be as close as possible to the area being welded.
  - 3.e. Ground the work or metal to be welded to a good electrical (earth) ground.
  - 3.f. Maintain the electrode holder, work clamp, welding cable and welding machine in good, safe operating condition. Replace damaged insulation.
  - 3.g. Never dip the electrode in water for cooling.
  - 3.h. Never simultaneously touch electrically “hot” parts of electrode holders connected to two welders because voltage between the two can be the total of the open circuit voltage of both welders.
  - 3.i. When working above floor level, use a safety belt to protect yourself from a fall should you get a shock.
  - 3.j. Also see Items 6.c. and 8.



## ARC RAYS CAN BURN.



- 4.a. Use a shield with the proper filter and cover plates to protect your eyes from sparks and the rays of the arc when welding or observing open arc welding. Headshield and filter lens should conform to ANSI Z87.1 standards.
- 4.b. Use suitable clothing made from durable flame-resistant material to protect your skin and that of your helpers from the arc rays.
- 4.c. Protect other nearby personnel with suitable, non-flammable screening and/or warn them not to watch the arc nor expose themselves to the arc rays or to hot spatter or metal.



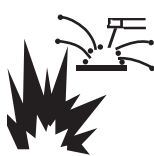
## FUMES AND GASES CAN BE DANGEROUS.



- 5.a. Welding may produce fumes and gases hazardous to health. Avoid breathing these fumes and gases. When welding, keep your head out of the fume. Use enough ventilation and/or exhaust at the arc to keep fumes and gases away from the breathing zone. **When welding hardfacing (see instructions on container or SDS) or on lead or cadmium plated steel and other metals or coatings which produce highly toxic fumes, keep exposure as low as possible and within applicable OSHA PEL and ACGIH TLV limits using local exhaust or mechanical ventilation unless exposure assessments indicate otherwise. In confined spaces or in some circumstances, outdoors, a respirator may also be required. Additional precautions are also required when welding on galvanized steel.**
- 5.b. The operation of welding fume control equipment is affected by various factors including proper use and positioning of the equipment, maintenance of the equipment and the specific welding procedure and application involved. Worker exposure level should be checked upon installation and periodically thereafter to be certain it is within applicable OSHA PEL and ACGIH TLV limits.
- 5.c. Do not weld in locations near chlorinated hydrocarbon vapors coming from degreasing, cleaning or spraying operations. The heat and rays of the arc can react with solvent vapors to form phosgene, a highly toxic gas, and other irritating products.
- 5.d. Shielding gases used for arc welding can displace air and cause injury or death. Always use enough ventilation, especially in confined areas, to insure breathing air is safe.
- 5.e. Read and understand the manufacturer’s instructions for this equipment and the consumables to be used, including the Safety Data Sheet (SDS) and follow your employer’s safety practices. SDS forms are available from your welding distributor or from the manufacturer.
- 5.f. Also see item 1.b.




## WELDING AND CUTTING SPARKS CAN CAUSE FIRE OR EXPLOSION.



- 6.a. Remove fire hazards from the welding area. If this is not possible, cover them to prevent the welding sparks from starting a fire. Remember that welding sparks and hot materials from welding can easily go through small cracks and openings to adjacent areas. Avoid welding near hydraulic lines. Have a fire extinguisher readily available.
- 6.b. Where compressed gases are to be used at the job site, special precautions should be used to prevent hazardous situations. Refer to "Safety in Welding and Cutting" (ANSI Standard Z49.1) and the operating information for the equipment being used.
- 6.c. When not welding, make certain no part of the electrode circuit is touching the work or ground. Accidental contact can cause overheating and create a fire hazard.
- 6.d. Do not heat, cut or weld tanks, drums or containers until the proper steps have been taken to insure that such procedures will not cause flammable or toxic vapors from substances inside. They can cause an explosion even though they have been "cleaned". For information, purchase "Recommended Safe Practices for the Preparation for Welding and Cutting of Containers and Piping That Have Held Hazardous Substances", AWS F4.1 from the American Welding Society (see address above).
- 6.e. Vent hollow castings or containers before heating, cutting or welding. They may explode.
- 6.f. Sparks and spatter are thrown from the welding arc. Wear oil free protective garments such as leather gloves, heavy shirt, cuffless trousers, high shoes and a cap over your hair. Wear ear plugs when welding out of position or in confined places. Always wear safety glasses with side shields when in a welding area.
- 6.g. Connect the work cable to the work as close to the welding area as practical. Work cables connected to the building framework or other locations away from the welding area increase the possibility of the welding current passing through lifting chains, crane cables or other alternate circuits. This can create fire hazards or overheat lifting chains or cables until they fail.
- 6.h. Also see item 1.c.
- 6.i. Read and follow NFPA 51B "Standard for Fire Prevention During Welding, Cutting and Other Hot Work", available from NFPA, 1 Batterymarch Park, PO box 9101, Quincy, MA 02269-9101.
- 6.j. Do not use a welding power source for pipe thawing.



## CYLINDER MAY EXPLODE IF DAMAGED.

- 7.a. Use only compressed gas cylinders containing the correct shielding gas for the process used and properly operating regulators designed for the gas and pressure used. All hoses, fittings, etc. should be suitable for the application and maintained in good condition. 
- 7.b. Always keep cylinders in an upright position securely chained to an undercarriage or fixed support.
- 7.c. Cylinders should be located:
  - Away from areas where they may be struck or subjected to physical damage.
  - A safe distance from arc welding or cutting operations and any other source of heat, sparks, or flame.
- 7.d. Never allow the electrode, electrode holder or any other electrically "hot" parts to touch a cylinder.
- 7.e. Keep your head and face away from the cylinder valve outlet when opening the cylinder valve.
- 7.f. Valve protection caps should always be in place and hand tight except when the cylinder is in use or connected for use.
- 7.g. Read and follow the instructions on compressed gas cylinders, associated equipment, and CGA publication P-1, "Precautions for Safe Handling of Compressed Gases in Cylinders," available from the Compressed Gas Association, 14501 George Carter Way Chantilly, VA 20151.



## FOR ELECTRICALLY POWERED EQUIPMENT.



- 8.a. Turn off input power using the disconnect switch at the fuse box before working on the equipment.
- 8.b. Install equipment in accordance with the U.S. National Electrical Code, all local codes and the manufacturer's recommendations.
- 8.c. Ground the equipment in accordance with the U.S. National Electrical Code and the manufacturer's recommendations.

**Refer to**  
**<http://www.lincolnelectric.com/safety>**  
**for additional safety information.**

As a rule of thumb, for many mild steel electrode, if the air is visibly clear and you are comfortable, then the ventilation is generally adequate for your work. The most accurate way to determine if the worker exposure does not exceed the applicable exposure limit for compounds in the fumes and gases is to have an industrial hygienist take and analyze a sample of the air you are breathing. This is particularly important if you are welding with stainless, hardfacing or Special Ventilation products. All Lincoln MSDS have a maximum fume guideline number. If exposure to total fume is kept below that number, exposure to all fume from the electrode (not coatings or plating on the work) will be below the TLV.

There are steps that you can take to identify hazardous substances in your welding environment. Read the product label and material safety data sheet for the electrode posted in the work place or in the electrode or flux container to see what fumes can be reasonably expected from use of the product and to determine if special ventilation is needed. Secondly, know what the base metal is and determine if there is any paint, plating, or coating that could expose you to toxic fumes and/or gases. Remove it from the metal being welded, if possible. If you start to feel uncomfortable, dizzy or nauseous, there is a possibility that you are being overexposed to fumes and gases, or suffering from oxygen deficiency. Stop welding and get some fresh air immediately. Notify your supervisor and co-workers so the situation can be corrected and other workers can avoid the hazard. Be sure you are following these safe practices, the consumable labeling and MSDS to improve the ventilation in your area. Do not continue welding until the situation has been corrected.

NOTE: The MSDS for all Lincoln consumables is available on Lincoln's web-site: [www.lincolnelectric.com](http://www.lincolnelectric.com)

Before we turn to the methods available to control welding fume exposure, you should understand a few basic terms:

**Natural Ventilation** is the movement of air through the workplace caused by natural forces. Outside, this is usually the wind. Inside, this may be the flow of air through open windows and doors.

**Mechanical Ventilation** is the movement of air through the workplace caused by an electrical device such as a portable fan or permanently mounted fan in the ceiling or wall.

**Source Extraction** (Local Exhaust) is a mechanical device used to capture welding fume at or near the arc and filter contaminants out of the air.

The ventilation or exhaust needed for your application depends upon many factors such as:

- Workspace volume
- Workspace configuration
- Number of welders
- Welding process and current
- Consumables used (mild steel, hardfacing, stainless, etc.)
- Allowable levels (TLV, PEL, etc.)
- Material welded (including paint or plating)
- Natural airflow

Your work area has adequate ventilation when there is enough ventilation and/or exhaust to control worker exposure to hazardous materials in the welding fumes and gases so the applicable limits for those materials is not exceeded. See chart of TLV and PEL for Typical Electrode Ingredients, the OSHA PEL

(Permissible Exposure Limit), and the recommended guideline, the ACGIH TLV (Threshold Limit Value), for many compounds found in welding fume.

### Ventilation

There are many methods which can be selected by the user to provide adequate ventilation for the specific application. The following section provides general information which may be helpful in evaluating what type of ventilation equipment may be suitable for your application. When ventilation equipment is installed, you should confirm worker exposure is controlled within applicable OSHA PEL and/or ACGIH TLV. According to OSHA regulations, when welding and cutting (mild steels), natural ventilation is usually considered sufficient to meet requirements, provided that:

1. The room or welding area contains at least 10,000 cubic feet (about 22' x 22' x 22') for each welder.
2. The ceiling height is not less than 16 feet.
3. Cross ventilation is not blocked by partitions, equipment, or other structural barriers.
4. Welding is not done in a confined space.

Spaces that do not meet these requirements should be equipped with mechanical ventilating equipment that exhausts at least 2000 CFM of air for each welder, except where local exhaust hoods or booths, or air-line respirators are used.

### Important Safety Note:

**When welding with electrodes which require special ventilation such as stainless or hardfacing (see instructions on container or MSDS) or on lead or cadmium plated steel and other metals or coatings which produce hazardous fumes, keep exposure as low as possible and below exposure limit values (PEL and TLV) for materials in the fume using local exhaust or mechanical ventilation. In coned spaces or in some circumstances, for example outdoors, a respirator may be required if exposure cannot be controlled to the PEL or TLV. (See MSDS and chart of TLV and PEL for Typical Electrode Ingredients.) Additional precautions are also required when welding on galvanized steel.**

**BIBLIOGRAPHY AND SUGGESTED READING**

ANSI Z87.1, Practice for Occupational and Educational Eye and Face Protection, American National Standards Institute, 11 West 42nd Street, New York, NY 10036.

Arc Welding and Your Health: A Handbook of Health Information for Welding. Published by The American Industrial Hygiene Association, 2700 Prosperity Avenue, Suite 250, Fairfax, VA 22031-4319.

NFPA Standard 51B, Cutting and Welding Processes, National Fire Protection Association, 1 Batterymarch Park, P.O. Box 9146, Quincy, MA 02269-9959.

OSHA General Industry Standard 29 CFR 1910 Subpart Q. OSHA Hazard Communication Standard 29 CFR 1910.1200. Available from the Occupational Safety and Health Administration at <http://www.osha.org> or contact your local OSHA office.

The following publications are published by The American Welding Society, P.O. Box 351040, Miami, Florida 33135. AWS publications may be purchased from the American Welding Society at <http://www.aws.org> or by contacting the AWS at 800-443-9353.

ANSI, Standard Z49.1, Safety in Welding, Cutting and Allied Processes. Z49.1 is now available for download at no charge at <http://www.lincolnelectric.com/community/safety/> or at the AWS website <http://www.aws.org>.

AWS F1.1, Method for Sampling Airborne Particulates Generated by Welding and Allied Processes.

AWS F1.2, Laboratory Method for Measuring Fume Generation Rates and Total Fume Emission of Welding and Allied Processes.

AWS F1.3, Evaluating Contaminants in the Welding Environment: A Strategic Sampling Guide.

AWS F1.5, Methods for Sampling and Analyzing Gases from Welding and Allied Processes.

AWS F3.2, Ventilation Guide for Welding Fume Control

AWS F4.1, Recommended Safe Practices for the Preparation for Welding and Cutting of Containers and Piping That Have Held Hazardous Substances.

AWS SHF, Safety and Health Facts Sheets. Available free of charge from the AWS website at <http://www.aws.org>.

**LISTED BELOW ARE SOME TYPICAL INGREDIENTS IN WELDING ELECTRODES AND THEIR TLV (ACGIH) GUIDELINES AND PEL (OSHA) EXPOSURE LIMITS**

INGREDIENTS	CAS No.	TLV mg/m <sup>3</sup>	PEL mg/m <sup>3</sup>
Aluminum and/or aluminum alloys (as Al)*****	7429-90-5	1.0	15
Aluminum oxide and/or Bauxite*****	1344-28-1	1.0	5**
Barium compounds (as Ba)*****	513-77-9	0.5	0.5
Chromium and chromium alloys or compounds (as Cr)*****	7440-47-3	0.5(b)	0.5(b)
Hexavalent Chromium (Cr VI)	18540-29-9	0.05(b)	.005(b)
Copper Fume	7440-50-8	0.2	0.1
Cobalt Compounds	7440-48-4	0.02	0.1
Fluorides (as F)	7789-75-5	2.5	2.5
Iron	7439-89-6	10*	10*
Limestone and/or calcium carbonate	1317-65-3	10*	15
Lithium compounds (as Li)	554-13-2	15	10*
Magnesite	1309-48-4	10	15
Magnesium and/or magnesium alloys and compounds (as Mg)	7439-95-4	10*	10*
Manganese and/or manganese alloys and compounds (as Mn)*****	7439-96-5	0.02	5.0(c)
Mineral silicates	1332-58-7	5**	5**
Molybdenum alloys (as Mo)	7439-98-7	10	10
Nickel*****	7440-02-0	0.1	1
Silicates and other binders	1344-09-8	10*	10*
Silicon and/or silicon alloys and compounds (as Si)	7440-21-3	10*	10*
Strontium compounds (as Sr)	1633-05-2	10*	10*
Zirconium alloys and compounds (as Zr)	12004-83-0	5	5

**Supplemental Information:**

(\*) Not listed. Nuisance value maximum is 10 milligrams per cubic meter. PEL value for iron oxide is 10 milligrams per cubic meter. TLV value for iron oxide is 5 milligrams per cubic meter.

(\*\*) As respirable dust.

(\*\*\*\*) Subject to the reporting requirements of Sections 311, 312, and 313 of the Emergency Planning and Community Right-to-Know Act of 1986 and of 40CFR 370 and 372.

(b) The PEL for chromium (VI) is .005 milligrams per cubic meter as an 8 hour time weighted average. The TLV for water-soluble chromium (VI) is 0.05 milligrams per cubic meter. The TLV for insoluble chromium (VI) is 0.01 milligrams per cubic meter.

(c) Values are for manganese fume. STEL (Short Term Exposure Limit) is 3.0 milligrams per cubic meter. OSHA PEL is a ceiling value.

(\*\*\*\*) The TLV for soluble barium compounds is 0.5 mg/m<sup>3</sup>.

TLV and PEL values are as of October 2013. Always check Safety Data Sheet (SDS) with product or on the Lincoln Electric website at <http://www.lincolnelectric.com>

**INSTALLATION .....SECTION A**  
 TECHNICAL SPECIFICATIONS .....A-1  
 GENERAL DESCRIPTION .....A-2  
 COMPONENTS .....A-3  
 UNPACKING .....A-3  
 INSTALLATION .....A-4  
 STATIFLEX 200-M(/HE) SINGLE ARM .....A-4  
 STATIFLEX 200-M DUAL ARM .....A-6

**OPERATION .....SECTION B**  
 USERS .....B-2  
 INTENDED USE .....B-2  
 MODIFICATIONS.....B-2  
 OPERATION .....B-2  
 PRODUCT COMBINATIONS .....B-4  
 USE .....B-4  
 FILTER MAINTENANCE INDICATOR.....B-4

**OPTIONS .....SECTION C**  
 MAINTENANCE .....  
 DISPOSAL

**MAINTENANCE.....SECTION D**  
 PERIODIC MAINTENANCE.....D-1  
 FILTER REPLACEMENT .....D-2

**TROUBLESHOOTING .....SECTION E**

**WIRING DIAGRAM .....SECTION F**

**Parts List .....parts.lincolnelectric.com**

Content/details may be changed or updated without notice. For most current Instruction Manuals, go to [parts.lincolnelectric.com](http://parts.lincolnelectric.com).



**TECHNICAL SPECIFICATIONS -**  
**K1654-4 - Single Arm Base Unit**  
**K1654-5 - Dual Arm Base Unit**  
**K1654-6 - High Efficiency Single Arm Base Unit**

WEIGHT	
SINGLE ARM	90 LBS (41 KGS)
DUAL ARM	102 LBS (46 KGS)

OPERATING CAPACITY	
EXTRACTOR TYPE	LOW VACUUM; HIGH VOLUME

AIRFLOW RATE	
STATIFLEX 200-M/(HE) SINGLE ARM	MAX. 735 CFM (1,250 M <sup>3</sup> /H)
STATIFLEX 200-M DUAL ARM	MAX. 1,200 CFM (2,040 M <sup>3</sup> /H) AT SIMULTANEOUS USE OF TWO SF2400

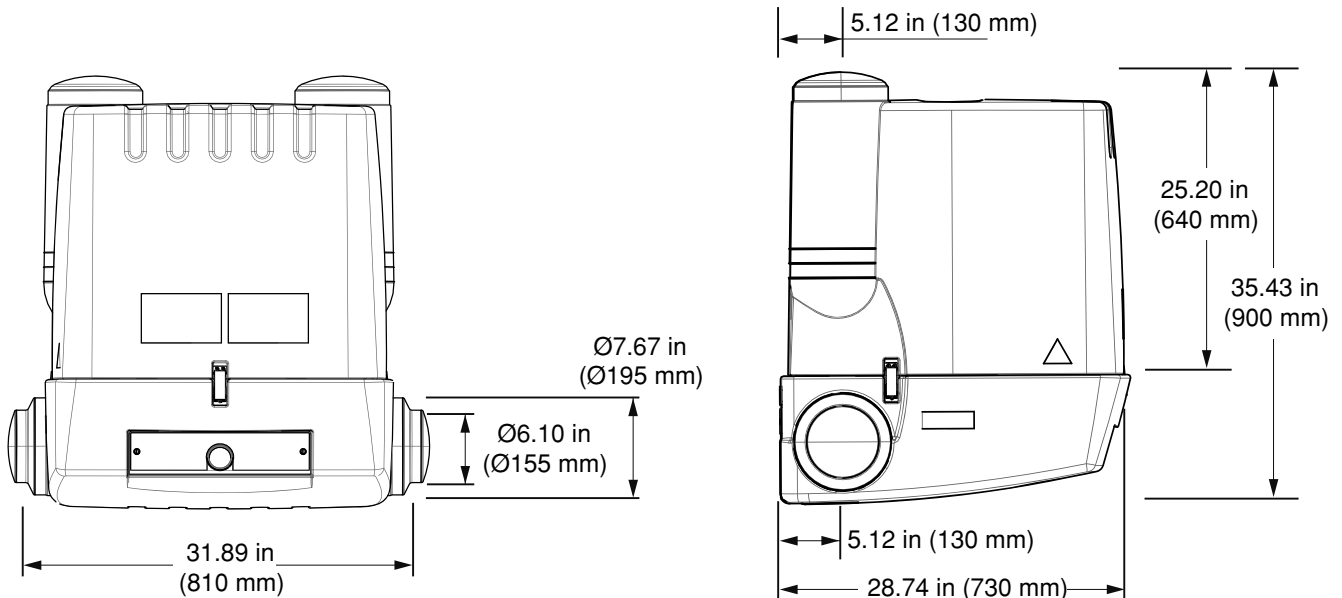
FILTER TYPE	
STATIFLEX 200-M SINGLE/ DUAL ARM BASE UNIT:	DISPOSABLE CELLULOSE LONGLIFE FILTER CARTRIDGE WITH PRECOAT
STATIFLEX 200-M/HE SINGLE ARM BASE UNIT:	DISPOSABLE CELLULOSE / POLYESTER BLEND LONGLIFE FILTER

FILTER CLASS (ACCORDING TO ASHRAE 52.2)	
STATIFLEX 200-M SINGLE/DUAL ARM	UNTREATED: MERV 11 TREATED: MERV 14
STATIFLEX 200-M/HE SINGLE ARM	MERV 16

FILTER SURFACE AREA
538 FT <sup>2</sup> (50 M <sup>2</sup> )

AMBIENT CONDITIONS	
MINIMUM TEMPERATURE	41°F (5°C)
NOMINAL	68° F (20° C)
MAXIMUM TEMPERATURE	113°F (45°C)
MAXIMUM RELATIVE HUMIDITY	80%

**DIMENSIONS**



## GENERAL DESCRIPTION

This instruction manual describes three base units:

- K1654-4 Statiflex 200-M Single Arm stationary filter unit with disposable filter cartridge - filter class MERV 11 (untreated); MERV 14 (treated)
- K1654-5 Statiflex 200-M Dual Arm stationary filter unit with disposable filter cartridge - filter class MERV 11 (untreated); MERV 14 (treated)
- K1654-6 Statiflex 200-M/HE Single Arm stationary filter unit with high efficiency disposable filter cartridge - filter class MERV 16

## STATIFLEX 200-M/(HE) SINGLE ARM

The K1654-4 Statiflex 200-M and K1654-6 Statiflex 200-M/HE Single Arm wall-mounted filter unit provides filtration for use with one extraction arm and one fan.

## STATIFLEX 200-M DUAL ARM

The K1654-5 Statiflex 200-M Dual Arm wall-mounted filter unit provides filtration for use with two extraction arms and two fans.

## STATIFLEX 200-M SINGLE/DUAL ARM

The Statiflex 200-M features an aluminum prefilter and a square disposable cellulose LongLife filter cartridge. This LongLife filter cartridge is provided with a precoat (ExtraCoat) to extend the lifespan and increase initial operating efficiency of the filter.

The Statiflex 200-M is used for filtering fume which is released during the most common welding processes, such as:

- MIG/MAG Solid Wire (GMAW)
- MIG/MAG Flux Cored Wire (FCAW)
- TIG (GTAW) Welding
- Stick Welding (MMA or SMAW)
- Autogeneous Welding

The Statiflex 200-M is designed for light to medium duty, intermittent welding applications listed above.

The Statiflex 200-M Single Arm system is recommended for annual consumable use of approximately\*:

- 1500 lbs. (700 kg) GMAW or FCAW or GTAW
- 1100 lbs. (500 kg) MMA or SMAW or Autogeneous

The Statiflex 200-M Dual Arm system is recommended for annual consumable use per workstation of approximately\*:

- 750 lbs. (350 kg) GMAW or FCAW or GTAW
- 550 lbs. (250 kg) MMA or SMAW or Autogeneous

\* Variables such as coatings (e.g. oil), base material, weld process, humidity and welding procedures can affect filter life and performance.

Unspecified amount and type of smells and odors, e.g. ozone (O<sup>3</sup>), can be captured with optional Activated Carbon Filter used within Statiflex 200-M unit.

## STATIFLEX 200-M/HE SINGLE ARM

The Statiflex 200-M/HE features an aluminum prefilter and a high efficiency square disposable cellulose/polyester blend LongLife filter cartridge.

The Statiflex 200-M/HE is used for filtering fume which is released during the most common welding processes, such as:

- MIG/MAG Solid Wire (GMAW)
- MIG/MAG Flux Cored Wire (FCAW)
- TIG (GTAW) Welding
- Stick Welding (MMA or SMAW)
- Autogeneous Welding

The Statiflex 200-M /HE is designed for light to medium duty, intermittent welding applications listed above.

The Statiflex 200-M/HE Single Arm system is recommended for annual consumable use of approximately\*:

- 500 lbs (250 kg) GMAW or FCAW or GTAW
- 385 lbs (175 kg) MMA or SMAW or autogeneous

\* Variables such as coatings (e.g. oil), base material, weld process and welding procedures can affect filter life and performance.

Unspecified amount and type of smells and odors, e.g. ozone (O<sup>3</sup>), can be captured with optional Activated Carbon Filter used within Statiflex 200-M/HE unit.

**COMPONENTS**

The Statiflex 200-M/(HE) Single and Dual Arm housing consists of the following main components and features (See Figure A.1):

- A. Outlet Opening (2)
- B. Filter Cover
- C. Filter Cover Plate
- D. Prefilter
- E. LongLife filter cartridge
- F. Latch (3)
- G. Bottom Housing
- H. Filter Maintenance Indicator
- I. Inlet Opening (2)
- J. Wall Mounting Bracket

**⚠ ATTENTION**

- The installer is responsible for following federal, state and local safety codes and regulations.
- Before drilling, verify locations of existing gas, water or electrical conduits.



**UNPACKING**

Check that the product package is complete. The package should contain:

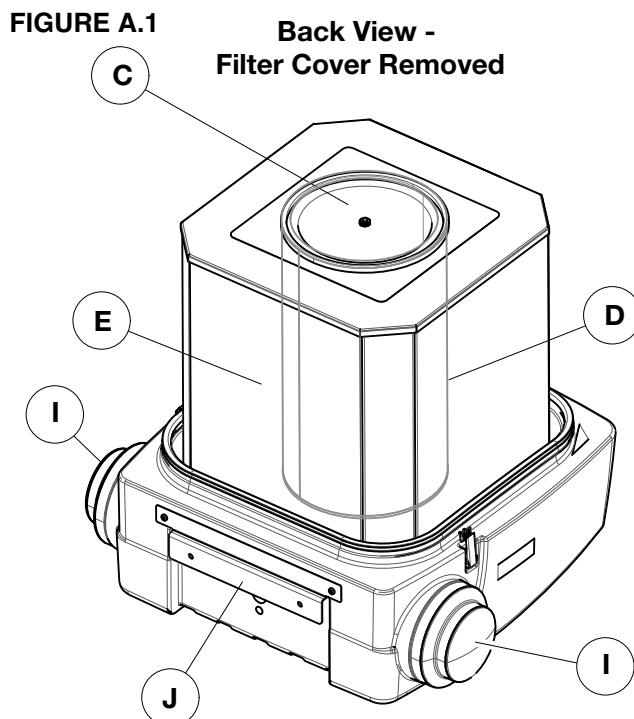
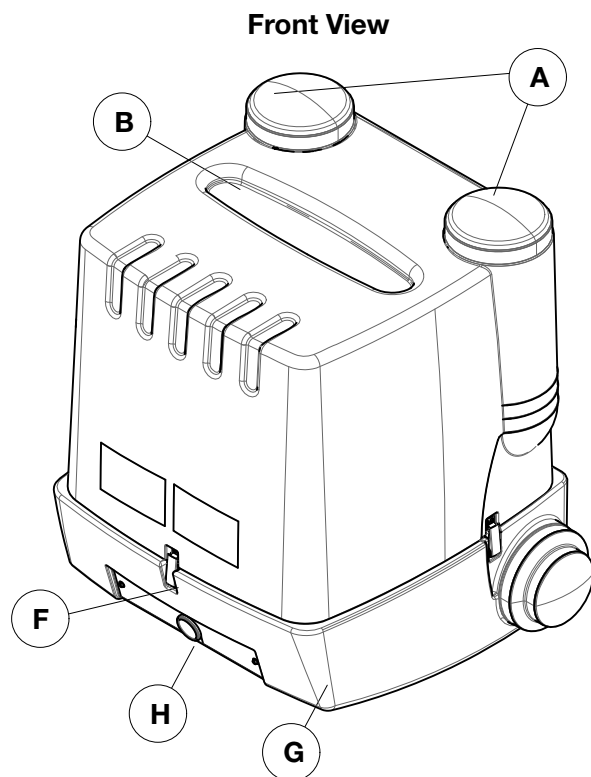
**STATIFLEX 200-M/(HE) SINGLE ARM**

- (1) Complete filter unit, with prefilter and filter cartridge installed
- (1) Mounting bracket
- (1) 8 in. Diameter Connection hose, length 4.9 ft.
- (2) 8 in. Diameter Hose clamps
- (2) Screws
- (1) Sealing Ring
- (1) Reducer
- (3) Sheet metal screws
- (1) Instruction manual

**STATIFLEX 200-M DUAL ARM**

- (1) Complete filter unit, with prefilter and filter cartridge installed
- (1) Mounting bracket
- (2) 8 in. Diameter Connection hoses, length 4.9 ft.
- (4) 8 in. Diameter Hose clamps
- (2) 8 in. Diameter Non-return valves
- (2) Reducers
- (2) Sealing Rings
- (2) Screws
- (12) Sheet metal screws
- (1) Instruction manual

If parts are missing or damaged, contact Lincoln Electric Automation Service 888-935-3878.



# INSTALLATION

For information on installation of fume extraction arm(s) and extraction fan(s), refer to the corresponding manuals.

NOTE: Mount the Statiflex 200-M, extraction fan(s) and fume extraction arm(s) as close as possible to the source of welding.

## ⚠ ATTENTION

Use adequate mounting hardware for installing the unit, corresponding with the type of wall. Be aware, the weight of the unit when unpacked is approx. 66 lbs (30 kg). As filter saturates it will increase in weight.



### STATIFLEX 200-M/(HE) SINGLE ARM

NOTE: In the standard configuration of the Statiflex 200-M/(HE) Single Arm system, the filter unit is positioned on the right side of the fan. However, it may be mounted on either side, as long as the connection hose reaches from the outlet of the fan to the inlet of the Statiflex 200-M/(HE).

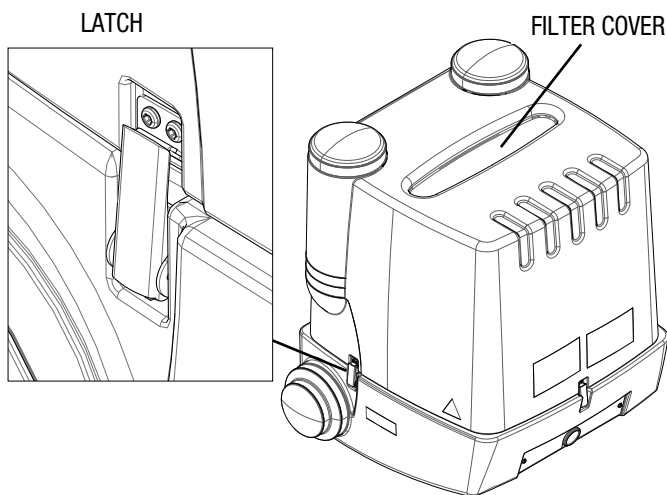
#### Installation Steps:

## ⚠ CAUTION

If the base is not completely disassembled, it may be possible that some plastic residue will get stuck in filter after step 1.

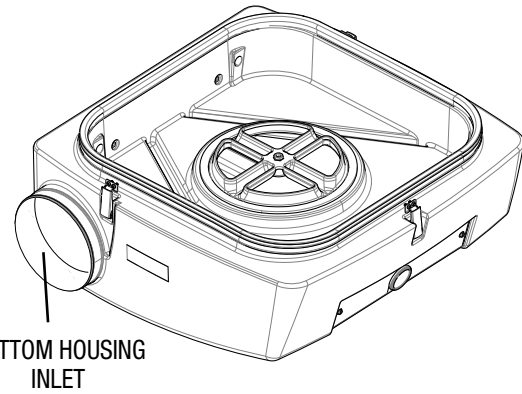
1. Loosen latches and remove the filter cover. See Figure A.2.

FIGURE A.2



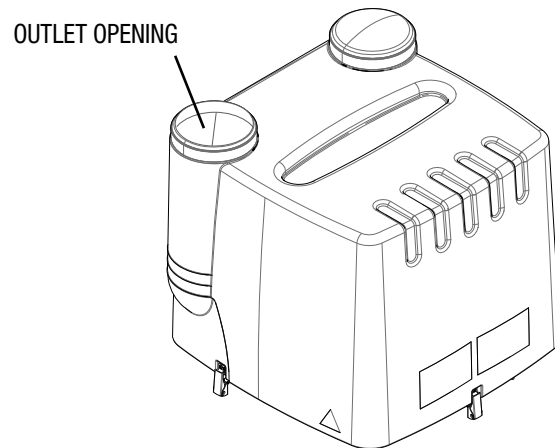
2. Using a multi-purpose power saw, cut open through the scribe mark on the left (or right) inlet of bottom housing; 8 in. (200 mm). See Figure A.3. If using a 6 in. diameter hose, cut open through the scribe mark on the 6 in. side of the left (or right) inlet of bottom housing.

FIGURE A.3



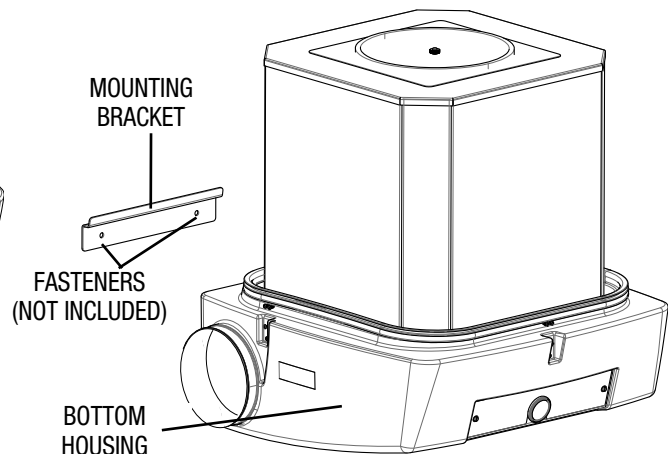
3. Using a multi-purpose power saw, cut open one two outlets of the filter cover See Figure A.4. The outlet shall be on the same side as the inlet, on base See Figure A.3.

FIGURE A.4



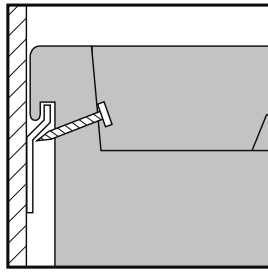
4. Secure the mounting bracket to the wall. See Figure A.5. Fasteners not included.
5. Secure the bottom housing onto the mounting bracket. See Figure A.5.

FIGURE A.5



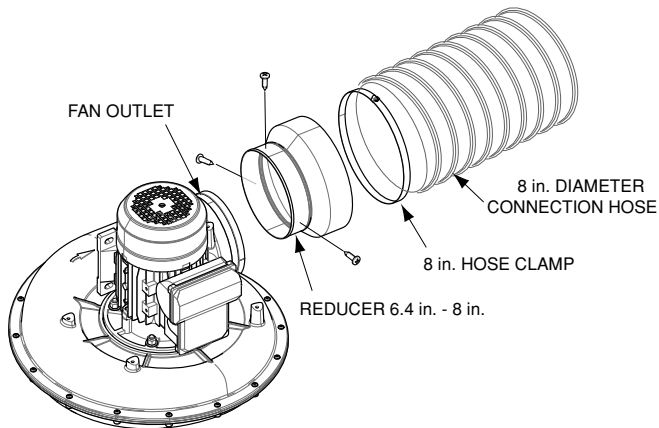
NOTE: The installation may be made permanent by running two screws in through the bottom housing against the mounting bracket. See Figure A.6.

FIGURE A.6



6. Replace the filter cover and fasten latches.
7. 8 in. hose gets clamped to the 8 in. side of the reducer with hose clamp. Then the 6.4" side of reducer goes over the outlet of the fan and secured with 3 sheet metal screws. See Figure A.7

FIGURE A.7

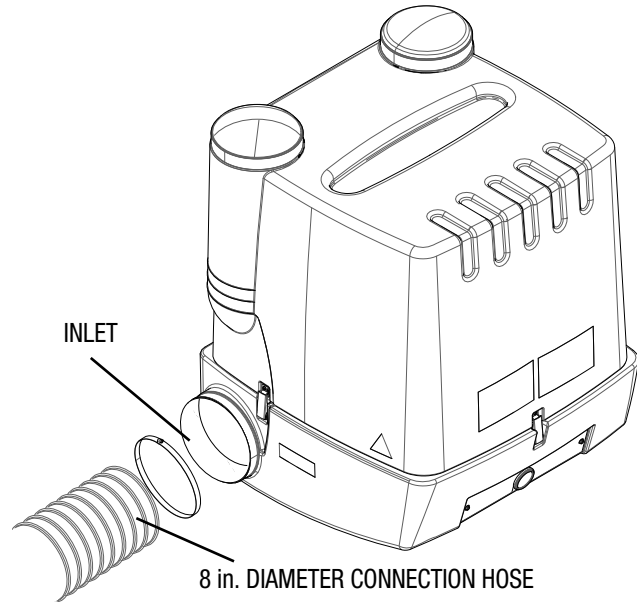


NOTE: When installing in combination with the SF4200 fan, first mount flexible outlet with steel bushing (included with SF4200 fan package) on the fan housing.

8. Install the 8 in. sealing ring on the inlet side of the hose.

9. Slide the 8 in. diameter connection hose over the sealing ring on the inlet by placing the hose all the way over the sealing ring. Secure with a 8 in. diameter hose clamp. See Figure A.8.

FIGURE A.8



**! ATTENTION**

In case the filter unit is mounted left of the SF2400 fan, the SF2400 will be in reverse position, resulting in centerpoints of fan outlet and Statiflex 200-M(/HE) inlet not aligning. This will not affect system performance.



**STATIFLEX 200-M DUAL ARM**

NOTE: The Statiflex 200-M Dual Arm should be mounted between two SF2400 extraction fans.

NOTE: Wall mounting brackets are not used with the LTA 2.0-CW arm.

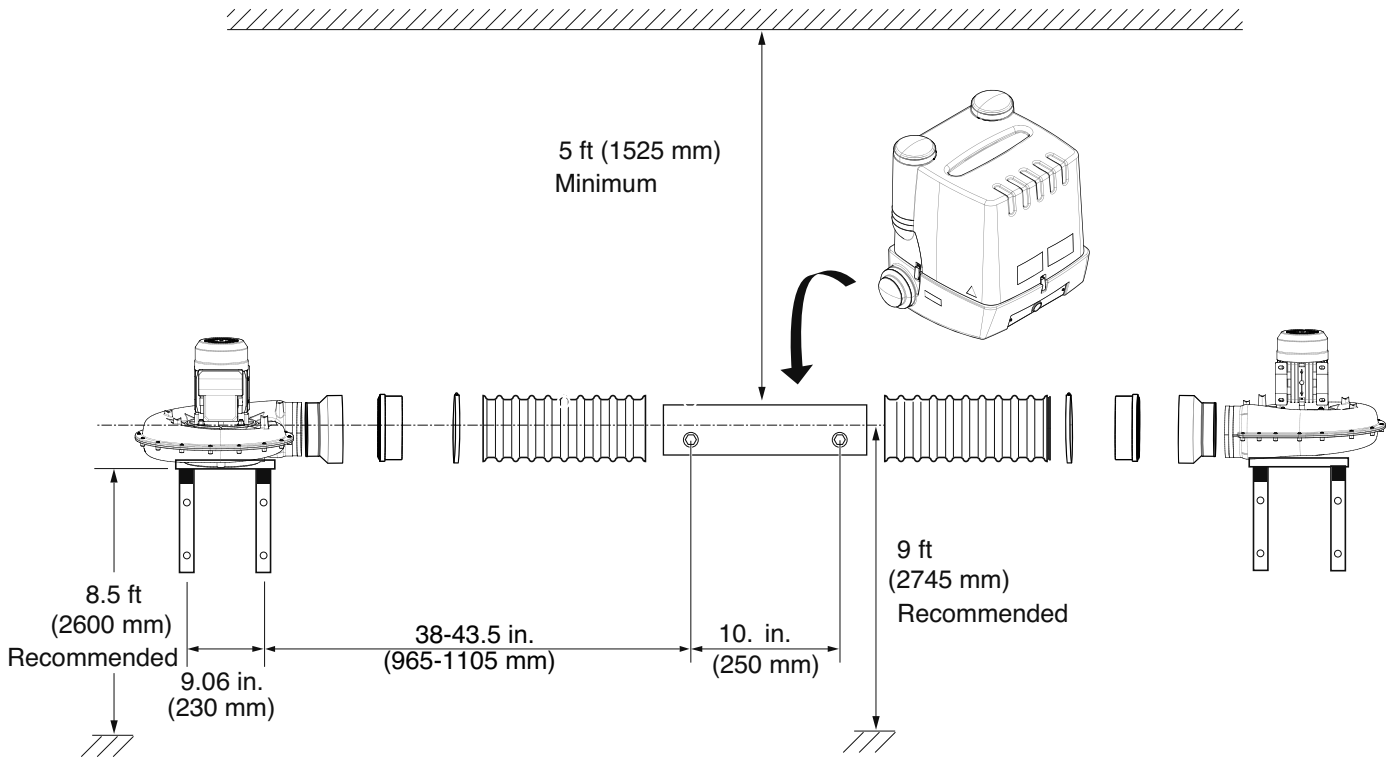
**Installation Steps:**

**! ATTENTION**

The SF 2400 which is mounted right of the Statiflex 200-M filter unit will be in reverse position, resulting in centerpoints of fan outlet and filter inlet not aligning. This will not affect system performance.

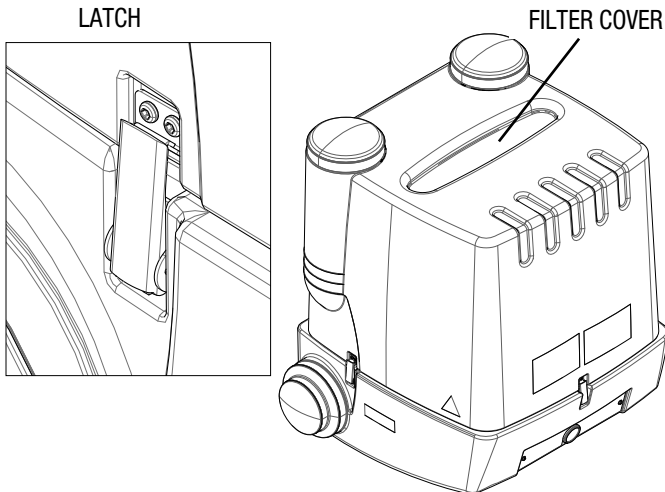


**FIGURE A.9**



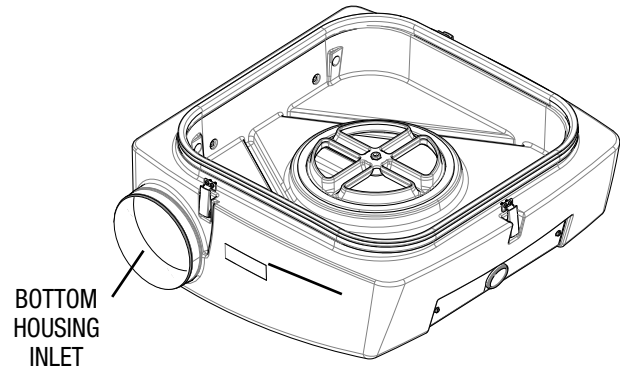
1. Loosen latches and remove the filter cover. See Figure A.10.

**FIGURE A.10**



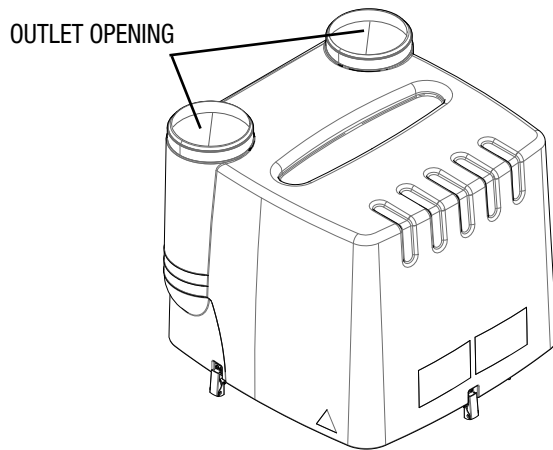
2. Using a multi-purpose power saw cut open through the scribe marks both inlets of bottom housing; cutouts to be Ø 8 in. (200 mm). See Figure A.11. If using a 6 in. diameter hose, cut open through the scribe mark on the 6 in. side of the inlets of bottom housing.

**FIGURE A.11**



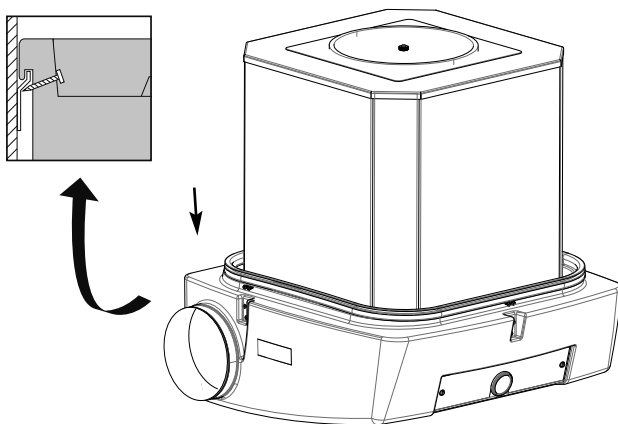
- Using a multi-purpose power saw, cut open both outlets of the filter cover. See Figure A.12.

**FIGURE A.12**



- Secure the mounting bracket to the wall. See Figure A.13. Fasteners not included.

**FIGURE A.13**

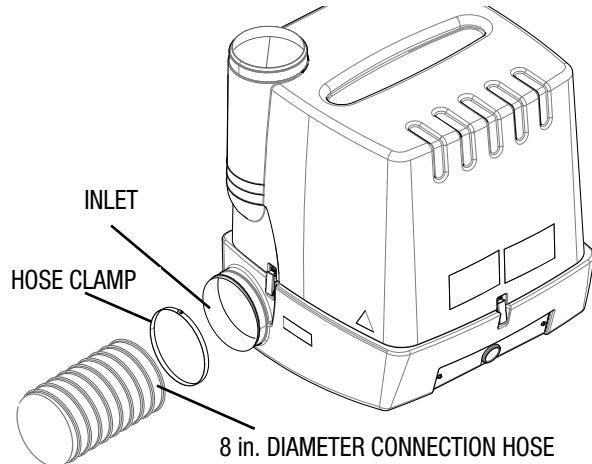


- Secure the bottom housing onto the mounting bracket. See Figure A.13.

NOTE: The installation may be made permanent by running two bolts in through the bottom housing against the mounting bracket (See Figure A.13).

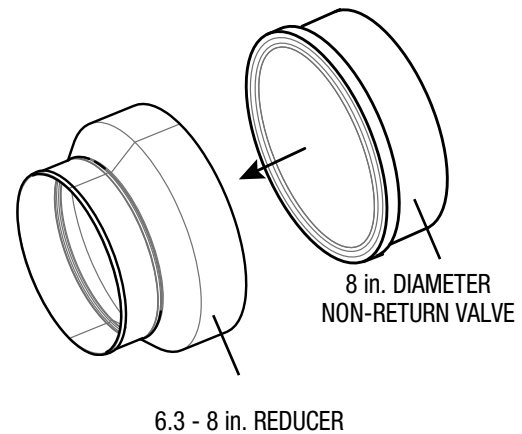
- Replace the filter cover and fasten latches.
- Install the 8 in. sealing rings on both inlets of the base.
- Fit the 8 in. diameter connection hoses over the sealing rings on the inlets and secure them with a 8 in. diameter hose clamp. See Figure A.14.

**FIGURE A.14**



- Fit the 8 in. diameter non-return valve into the 8 in. side of the reducer. See Figure A.15

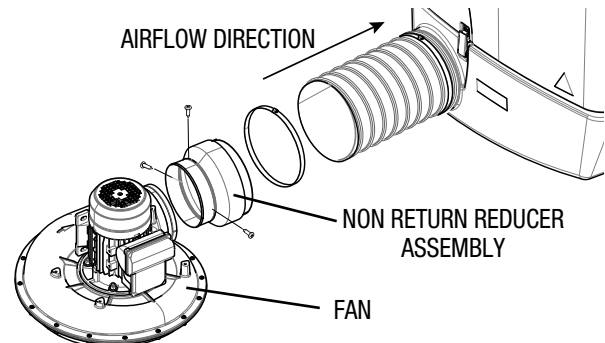
**FIGURE A.15**



NOTE: Be aware of the airflow direction from fan to filter unit. If non-return valves are installed backwards, airflow will be blocked. See Figure A-16

- Fit the other end of the 8 in. hose over the 8 in. diameter side of the reducer and secure it with an 8 in. diameter hose clamp. Slide the 6.4 in. side of the reducer over the outlet of the fan and sealing ring, then secure with 3 sheet metal screws. See figure A.16.

**FIGURE A.16**



# OPERATION

## Safety Precautions

The manufacturer does not accept any liability for damage to the product caused by a failure to follow the safety and other instructions in this manual, modifications made to equipment or by negligence during installation, use, maintenance and repair of the product mentioned in the safety pages of this document and any corresponding accessories.

Specific working conditions or used accessories may require additional safety instructions. Immediately contact your supplier if you detect a potential hazard when using the product.

## WARNING

The operation of welding fume control equipment is affected by various factors including proper use and positioning of the equipment, maintenance of the equipment and the specific welding procedure and application involved. Worker exposure level should be checked upon installation and periodically thereafter to be certain it is within applicable federal, state and/or local regulations and guidelines (i.e. OSHA PEL and ACGIH TLV limits in the U.S.).



If the product is used in combination with products or machines mentioned in the introduction of this manual, the safety instructions in the documentation of these products also apply.

- Routinely inspect the product and check it for damage.
- Use common sense. Stay alert and keep your attention to your work. Do not use the product when you are under the influence of drugs, alcohol or medicine.
- Make sure the facility is always sufficiently ventilated; this applies especially to confined spaces.
- Never install the product in front of entrances and exits which must be used by emergency services.
- Make sure that the facility where the equipment is installed contains sufficient approved fire extinguishers.
- The Statiflex 200-M functions only if the welding fumes are blown directly through an extraction fan into the filter. Therefore, never connect the Statiflex 200-M to the suction opening of the extraction fan.
- Air containing gases and particles such as OSHA defined hazardous chemicals, if recirculated, should be tested in accordance with applicable local, state and federal regulations and guidelines, such as OSHA PEL.

## WARNING

**FUMES and GASES can be dangerous.**

Welding may produce fumes and gases hazardous to health. Avoid breathing these fumes and gases.



When welding, keep your head out of the fume. Use enough ventilation and/or exhaust at the arc to keep fumes and gases away from the breathing zone. When welding with electrodes which require special ventilation such as stainless or hard facing (see instructions on container or MSDS) or on lead or cadmium plated steel and other metals or coatings which produce highly toxic fumes, keep exposure as low as possible and within applicable OSHA PEL and ACGIH TLV limits using local exhaust or mechanical ventilation. In confined spaces or in some circumstances, outdoors, a respirator may be required. Additional precautions are also required when welding on galvanized steel.

The operation of welding fume control equipment is affected by various factors including proper use and positioning of the equipment, maintenance of the equipment and the specific welding procedure and application involved. Worker exposure level should be checked upon installation and periodically thereafter to be certain it is within applicable OSHA PEL and ACGIH TLV.

## WARNING

**Fire hazard!**

Never use the product for filtering inflammable, glowing or burning particles, solids or liquids. Never use the product for filtering of reactive fumes (such as hydrochloric acid) or sharp particles.



## WARNING

- Avoid using the product for filtering dust particles which are released when welding surfaces treated with primer.
- Never use the product without prefilter and LongLife filter cartridge.





## WARNING

Only use the product for the welding processes described in the General Description. Avoid using the product for extracting and/or filtering fumes and gases which are released during the following (welding) processes:



- oxy-fuel cutting
- aluminum laser cutting
- oil-treated metal
- arc-air gouging
- oil mist
- paint mist
- heavy oil mist in welding fume
- hot gases (more than 40°C/100°F continuously)
- aggressive gases (e.g. from acids)
- plasma cutting
- grinding aluminum and magnesium
- flame spraying
- extraction of cement, saw dust, wood dust etc.
- sucking cigarettes, cigars, oiled tissues and other burning particles, objects and acids
- in all situations where explosions can occur

(This list is not comprehensive.)

If the product is used in above situations it could result in potential fire hazard, non-compliance with local regulations and reduction in product performance and life.

## USERS

This product should only be used by authorized, trained and qualified users.

## INTENDED USE

The product has been designed exclusively for filtering fume which is released during common weld processes. Using the product for other purposes is considered contrary to its intended use. Lincoln Electric accepts no liability for any damage resulting from such use. Only use the product in mechanically sound condition in accordance with its intended use and the instructions set forth in the user manual.

## MODIFICATIONS

Modifications of this product, other than those specified in this manual, are not allowed. Modifications will void the product warranty.

## OPERATION

The operation description below applies to all versions of the base unit. The air which contains welding fume is captured, extracted and filtered, in which the filtered air can be either recirculated or exhausted.

- First, the welding fume is extracted through one or two adjustable fume extraction arm(s) by one or two external extraction fan(s).
- Second, the fan unit(s) exhaust(s) the welding fume via a hose or duct into the Statiflex 200-M filter unit.
- Third, as the welding fume enters the Statiflex 200-M unit, it passes through the prefilter in the center of the LongLife filter cartridge. The prefilter separates larger particles, debris and sparks prior to the welding fume entering the LongLife filter.
- Fourth, the welding fume passes through the LongLife filter cartridge (stabilized).
- Fifth, after passing through the LongLife filter, the filtered air exits the Statiflex 200-M via the outlet opening(s) at top of unit. If desired, and local or federal regulations permit, filtered air can be recirculated back into work environment or exhausted outside of building.

## PRODUCT COMBINATIONS

### STATIFLEX 200-M/(HE) SINGLE ARM

In order to operate the Statiflex 200-M/(HE) Single Arm system, selection of following products is required:

- K1656-9 (1) SF2400 extraction fan required
- K1655-8 (1) LFA 3.1 10 ft. extraction arm; or
- K1655-9 (1) LFA 4.1 13 ft. extraction arm; or
- K1655-12 (1) LFA 2.0 6.5 ft. extraction arm; or
- K1655-13 (1) LFA 4.1-LC 13 ft. Low Ceiling extraction arm; or
- K1655-10 (1) LTA 2.0 telescopic extraction arm; or
- K1655-14 (1) LTA 2.0-CW telescopic extraction arm required
- K1494-2 (1) starter/overload switch for SF2400 fan (not required if using optional K1669-4 Lamp Kit with Arc Sensor)
- K1657-1 (1) Mounting Bracket (for LFA 3.1 and 4.1 extraction arms); or
- K1657-2 (1) Mounting Bracket (for LFA 2.0, LTA 2.0 and LFA 4.1-LC extraction arms)

### STATIFLEX 200-M DUAL ARM

In order to operate the Statiflex 200-M Dual Arm system, selection of following products is required:

- K1656-9 (2) SF2400 extraction fan required
- K1655-8 (2) LFA 3.1 10 ft. extraction arm; or
- K1655-9 (2) LFA 4.1 13 ft. extraction arm; or
- K1655-12 (2) LFA 2.0 6.5 ft. extraction arm; or
- K1655-13 (2) LFA 4.1-LC 13 ft. Low Ceiling extraction arm; or
- K1655-10 (2) LTA 2.0 telescopic extraction arm; or
- K1655-14 (2) LTA 2.0-CW telescopic extraction arm required\*
- K1494-2 (2) starter/overload switch for SF2400 fan (not required if using optional K1669-4 Lamp Kit with Arc Sensor)
- K1657-1 (2) Mounting Bracket (for LFA 3.1 and 4.1 extraction arms); or
- K1657-2 (2) Mounting Bracket (for LFA 2.0, LTA 2.0 and LFA 4.1-LC extraction arms)

\* Depending on specific application and work requirements, various combinations of extraction arms can be used -e.g. (1) K1655-9 LFA 3.1 arm and (1) K1655-10 LFA 2.0 arm.

## USE

### WARNING

Worker exposure level should be checked upon installation and periodically thereafter to be certain it is within applicable federal, state and/or local regulations and guidelines (i.e. OSHA PEL and ACGIH TLV limits in the U.S.).

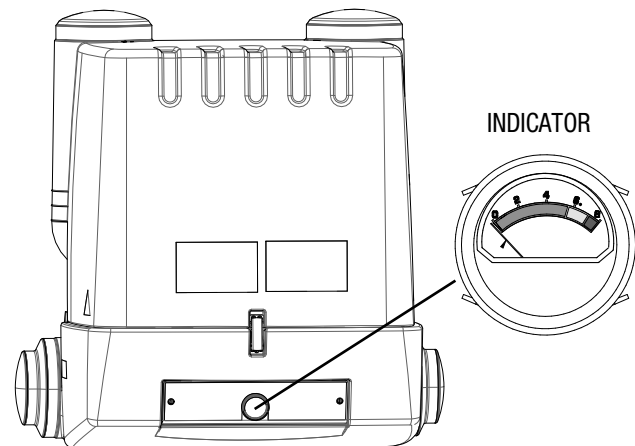


The Statiflex 200-M/(HE) is intended to be used with Lincoln Electric extraction arm(s) and fan(s). For information on use of these products, refer to the instruction manuals of the corresponding arm and/or fan.

## FILTER MAINTENANCE INDICATOR

The Statiflex 200-M/(HE) is provided with a Filter Maintenance Indicator (See Figure B.1). When using the filter unit, regularly check the Filter Maintenance Indicator when the fan is running. The indicator slowly moves from green to red as filter cartridge becomes saturated or clogged.

FIGURE B.1



When the Filter Maintenance Indicator is red, replace the LongLife® filter cartridge. See Filter Replacement for description.

### ATTENTION

The Filter Maintenance Indicator only functions when the fan(s) is/are in operation and the system is properly configured.



### WARNING

Saturation or clogging of the filter cartridge results in a decrease of the extraction capacity which could result in a higher localized concentration of welding fumes.



When the Filter Maintenance Indicator is entirely red while one fan is in operation, replace the LongLife filter cartridge. Filter replacement is described in Maintenance Section.

# ACCESSORIES

---

The following products can be obtained as an option:

- K1656-4 SF4200 in place of SF2400
- K1669-4 Lamp + Arc Sensor Kit for SF2400 fan
- K1669-10 Lamp + Arc Sensor Kit for SF4200 fan
- K1494-10 starter/overload switch for SF4200 fan (not required if using optional K1669-10 Lamp + Arc Sensor Kit)
- K1671-3 EC 2 - Extension Crane 7 ft.
- K1671-4 EC 4 - Extension Crane 14 ft.
- KP1852-1 Activated Carbon Filter

\* SF4200 fan unit(s) only used in standard package with Extension Crane configuration.

# MAINTENANCE

## WARNING

Have qualified personnel do the maintenance work. Turn the power off before working inside the machine. In some cases, it may be necessary to remove safety guards to perform required maintenance. Remove guards only when necessary and replace them when the maintenance requiring their removal is complete. Always use the greatest care when working near moving parts.

Do not put your hands near the blower fan. If a problem cannot be corrected by following the instructions, take the machine to the nearest Lincoln Field Service Shop.

### ELECTRIC SHOCK can kill.

- Do not touch electrically live parts or electrode with skin or wet clothing.
- Insulate yourself from work and ground.
- Always wear dry insulating gloves



### FUMES and GASES can be dangerous.

- Use in open, well ventilated areas or vent exhaust outside.



### MOVING PARTS can injure.

- Do not operate with doors open or guards off.
- Stop before servicing.
- Keep away from moving parts.



## WARNING

Use of equipment with clogged filters can cause fire.



NOTE: This manual clearly makes a distinction between service, maintenance and repair jobs which have to be carried out by the user and those which have to be exclusively carried out by well trained and authorized service engineers.

## DISPOSAL

After life of the product, dispose of product in accordance with federal, state or local regulations.

## ATTENTION

Do not use compressed air or high pressure water sprayer to clean LongLife filter cartridge, prefilter or optional Activated Carbon Filter.



The product has been designed to function with minimal maintenance. In order to guarantee optimal performance level, periodic maintenance and cleaning activities are required and described in this section.

Maintenance intervals can vary depending on the specific working conditions, such as ambient conditions, welding consumables and process(es), base material, coatings on base material and operator procedure. Therefore, it is required that regular inspection of the entire system is carried out. It is recommended a thorough inspection of the system occurs at least once every year.

### Observe the maintenance intervals given in this manual.

Overdue maintenance can lead to additional costs for repair and revisions and can render the warranty null and void.

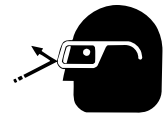
- Always use tools, materials, lubricants and service techniques which have been approved by the manufacturer. Never use worn tools and do not leave any tools in or on the product.
- Regularly clean or replace the prefilter.
- Replace the LongLife filter cartridge in time.
- Periodically clean the inside and outside housing.

## PERIODIC MAINTENANCE

The maintenance activities in Table D.1 indicated by [\*] can be carried out by the user; other activities are strictly reserved for well trained and authorized service engineers.

## WARNING

When cleaning equipment or replacing filter use personal protection equipment (PPE) such as gloves, respirators and protective clothing to protect against overexposure to particulate. It is recommended that a vacuum cleaner or wet methods be used to clean up any loose particulate that is present in the extraction arm. It is necessary to use a vacuum cleaner with HEPA rated filtration.



**TABLE D.1 – PERIODIC MAINTENANCE**

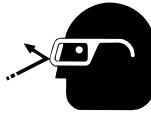
COMPONENT	ACTION	EVERY MONTH	EVERY 6 MONTHS
Filter Maintenance Indicator	Unless LongLife filter cartridge is clean, check if indicator moves upwards upon starting fan(s). If not, See Troubleshooting Section.	X [*]	
Prefilter, LongLife filter cartridge and optional Activated Carbon Filter	Check for damage, clogging and saturation. If damaged, clogged or saturated, See Filter Replacement.	X	
Filter cover and bottom housing	Clean inside with an industrial vacuum cleaner that meets OSHA guidelines for Cr6 housekeeping and remove the dust from the filter compartment.	X	
	Clean outside with a mild detergent.		X [*]
	Check for cracks or holes. If damaged, See Troubleshooting Section.	X [*]	
prefilter	Replace every filter change or clean with an industrial vacuum cleaner that meets OSHA guidelines for Cr6 housekeeping.	X	
Connection hose(s)	Check for cracks, holes or deformities. If damaged, See Troubleshooting Section.	X [*]	
Non-return valves (Dual Arm versions only)	Check butterfly flaps for free movement, deformities and particulate build-up or debris. If damaged, See Troubleshooting Section.	X	

**FILTER REPLACEMENT**



**WARNING**

Take necessary precautions so that you and your fellow workers are not overexposed to particulate. Wear suitable personal protection equipment, such as gloves, respirator, eye glass and protective clothing when disposing of the filter and particulate.



Check with local waste management or local agency(ies) for assistance in the disposal of filter. If filter has collected certain types of particulate which local agencies define as hazardous waste, filter may be classified as hazardous waste and will need to be disposed in accordance with federal, state and local regulations - which could vary from state to state, and between local municipalities within the state.

**Replacement Steps:**

See Figure D.1 for steps 1-8.

1. Disconnect the extraction fan(s) from the input power.
2. Loosen latches (A) and remove the filter cover (B).
3. Unscrew the knurled nut (C) and remove the filter cover plate (D).
4. Lift the LongLife filter cartridge (E) up and out of the filtration unit. It is not necessary to remove the prefilter (F) unless it needs replacement.
5. If required by federal, state and/or local regulations and guidelines, conceal filter in appropriate bag, e.g. plastic bag.
6. Clean the prefilter and filter compartment with an industrial vacuum cleaner that meets OSHA guidelines for Cr6 house-keeping.
7. Install a new LongLife filter cartridge.
8. Replace the dismantled parts in reverse order.

**LOGLIFE FILTER CARTRIDGE**

Replace the LongLife filter cartridge:

- when the Filter Maintenance Indicator (See Figure B.1) shows that the filter cartridge is saturated or clogged; or
- when the airflow is reduced to the point that extraction performance is no longer satisfactory; or
- when it has been damaged.

**PREFILTER**

Replace the prefilter:

- when it is saturated or clogged and can't be cleaned using a vacuum cleaner; or
- when it has been damaged.

NOTE: In case the prefilter has been damaged, it is recommended to also replace the LongLife filter cartridge.

**Replacement Steps:**

See Figure D.1 for steps 1-9.

1. Disconnect the extraction fan(s) from the input power.
2. Loosen latches (A) and remove the filter cover (B).
3. Unscrew the knurled nut (C) and remove the filter cover plate (D).
4. Lift the LongLife filter cartridge (E) up and out of the filtration unit.
5. Remove the prefilter (F).
6. If required by federal, state and/or local regulations and guidelines, conceal prefilter in appropriate bag, e.g. plastic bag.
7. Clean the filter compartment with an industrial vacuum cleaner that meets OSHA guidelines for Cr6 housekeeping.
8. Install a new prefilter.
9. Replace the dismantled parts in reverse order.

**ACTIVATED CARBON FILTER (OPTION)**

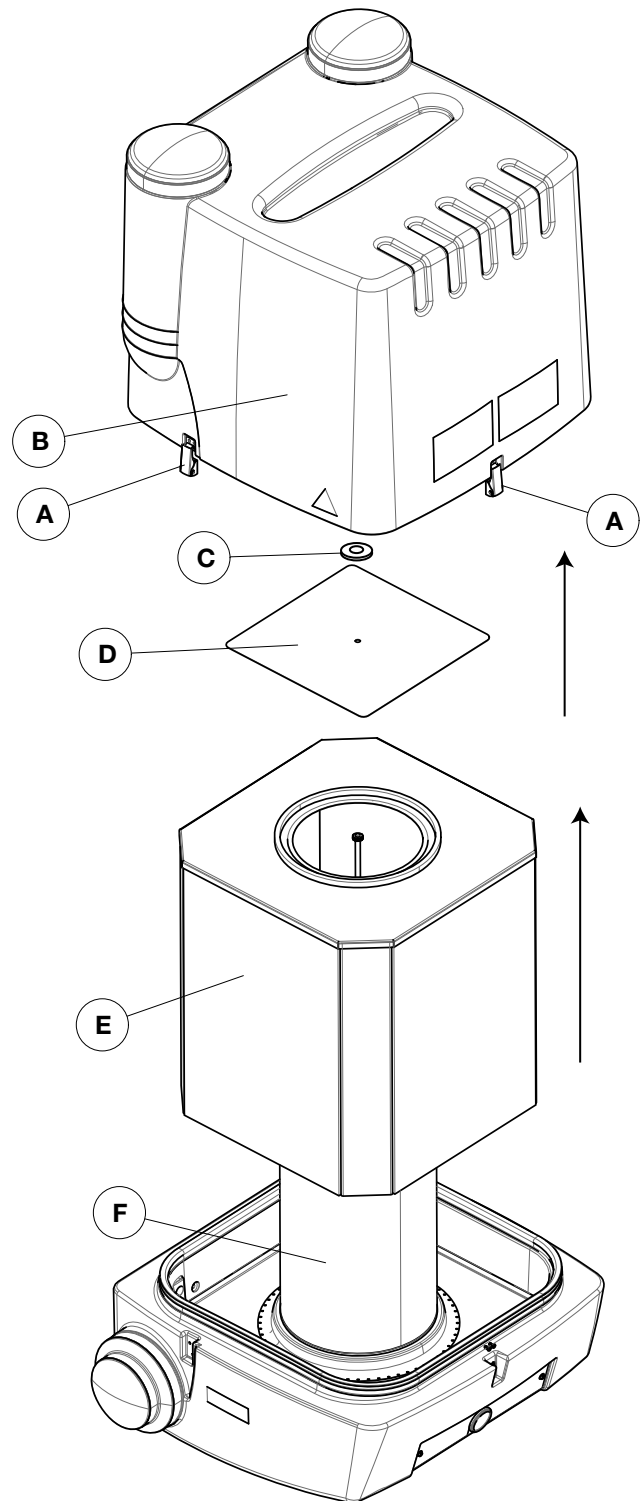
Replace the Activated Carbon Filter:

- When detecting odors and smells; or
- When it has been damaged.

**Replacement Steps:**

See Figure D.1 for steps 1-6.

1. Disconnect the extraction fan(s) from the input power.
2. Loosen latches (A) and remove the filter cover (B).
3. Unscrew the knurled nut (C) and remove the filter cover plate (D).
4. Remove the Activated Carbon Filter from the LongLife filter cartridge.
5. Install a new Activated Carbon Filter.
6. Replace the dismantled parts in reverse order.

**FIGURE D.1**

# TROUBLESHOOTING GUIDE



Service and Repair should only be performed by Lincoln Electric Factory Trained Personnel. Unauthorized repairs performed on this equipment may result in danger to the technician and machine operator and will invalidate your factory warranty. For your safety and to avoid ELECTRICAL SHOCK, please observe all safety notes and precautions detailed throughout this manual.

This Troubleshooting Guide is provided to help you locate and repair possible machine malfunctions. Simply follow the three-step procedure listed below.

## **Step 1. LOCATE PROBLEM (SYMPTOM).**

Look under the column labeled “PROBLEM (SYMPTOMS)”. This column describes possible symptoms that the machine may exhibit. Find the listing that best describes the symptom that the machine is exhibiting.

## **Step 2. POSSIBLE AREAS OF MISADJUSTMENT(S).**

The second column labeled “POSSIBLE AREA(S) OF MISADJUSTMENTS” lists the obvious external possibilities that may contribute to the machine symptom.

## **Step 3. RECOMMENDED COURSE OF ACTION**

This column provides a course of action for the Possible Areas of Misadjustment(s).

### **Service and Technical Support**

For information about specific adjustments, maintenance or repair jobs which are not dealt with in this manual, please contact Lincoln Electric Automation Department 888-935-3878.

Make sure you have the following data on hand:

- product name
- serial number
- purchase order (number + date) for warranty verification



If for any reason you do not understand the test procedures or are unable to perform the tests/repairs safely, contact your Lincoln Authorized Service Facility for technical troubleshooting assistance before you proceed.

**[WWW.LINCOLNELECTRIC.COM/LOCATOR](http://WWW.LINCOLNELECTRIC.COM/LOCATOR)**

Observe all Safety Guidelines detailed throughout this manual

PROBLEM (SYMPTOMS)	POSSIBLE AREAS OF MISADJUSTMENT(S)	RECOMMENDED COURSE OF ACTION
Faulty Filter Maintenance Indicator. Indicator does not indicate saturation level of pre-filter and/or LongLife filter cartridge.	Blocked indicator tubes.	Clean tubes with compressed air.
	Indicator leaking.	Replace Filter Maintenance Indicator.
Poor suction. Statiflex 200-M/(HE) does not function properly.	Outlet(s) blocked.	Remove obstructions from the outlet opening(s) and/or connected ductwork.
	LongLife filter cartridge clogged (check filter maintenance indicator - See Figure B.1).	Remove obstructions from the outlet opening(s) and/or connected ductwork.
	Pre-Filter clogged.	Clean (See Periodic Maintenance) or replace (See Pre-Filter) the pre-filter.
Dust or smoke coming out of the outlet opening(s). Pollution of the facility.	LongLife filter cartridge damaged.	Replace LongLife filter cartridge (See LongLife Filter Cartridge).
	Sealing on LongLife filter cartridge damaged.	Replace LongLife filter cartridge (See LongLife Filter Cartridge).
Dust or smoke coming out of the inlet connection(s). Pollution of the facility.	Outlet(s) blocked.	Remove obstructions from the outlet opening(s) and/or connected ductwork.
	LongLife filter cartridge clogged (check filter maintenance indicator - See Figure B.1).	Replace LongLife filter cartridge (See LongLife Filter Cartridge).
	Pre-Filter clogged.	Clean (See Periodic Maintenance) or replace (See Pre-Filter) the pre-filter.
	Non-return valve(s) installed incorrectly.	Install non-return valve(s) correctly.
Dust or smoke coming out of one arm (Dual Arm versions only). Pollution of the facility.	Related non-return valve installed incorrectly.	Install non-return valve correctly.
	Related non-return valve damaged.	Replace non-return valve.
Dust or smoke coming out of bottom housing. Pollution of the facility.	Cracks or holes in bottom housing.	Replace bottom housing.

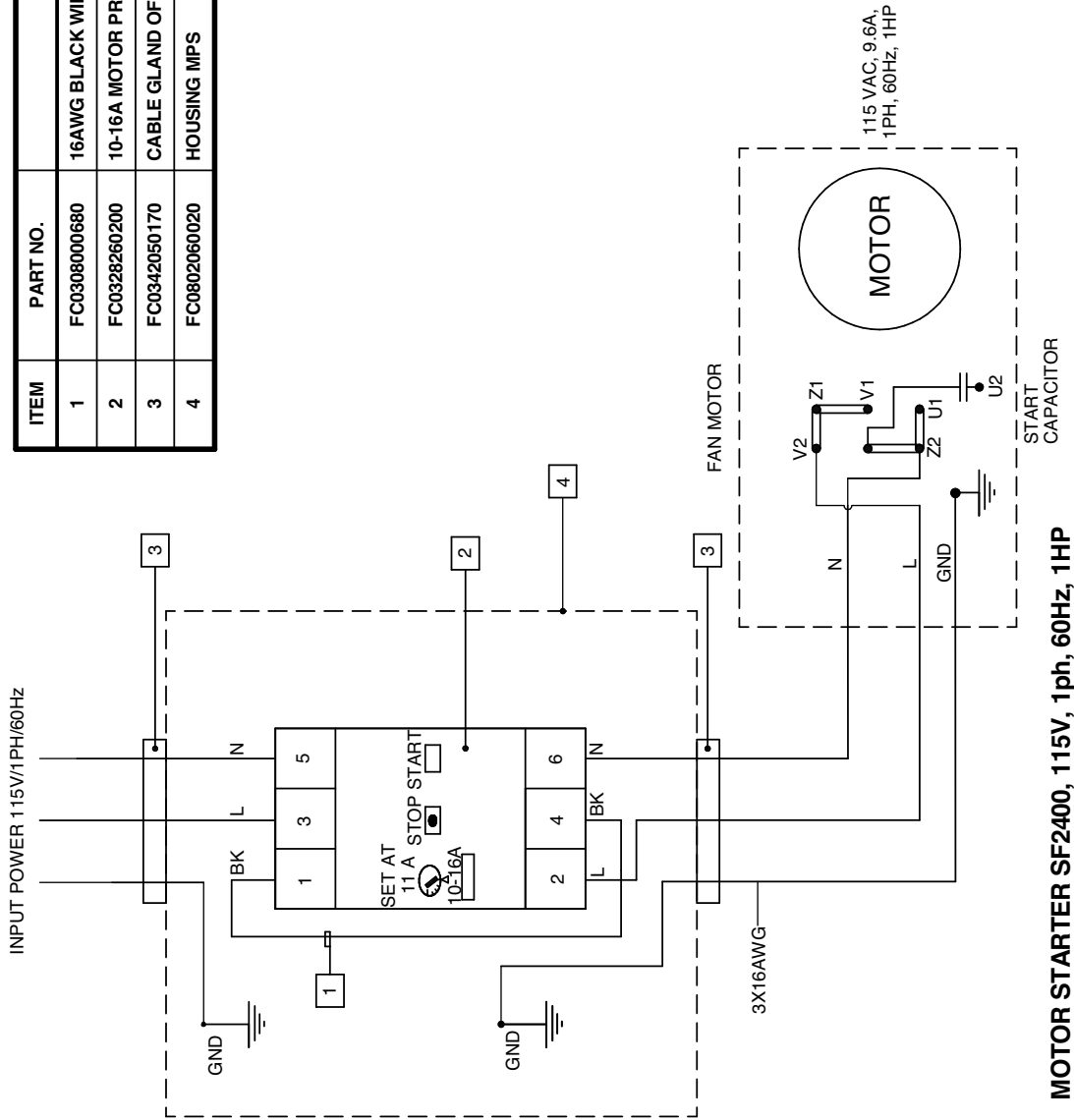


If for any reason you do not understand the test procedures or are unable to perform the tests/repairs safely, contact your Lincoln Authorized Service Facility for technical troubleshooting assistance before you proceed.

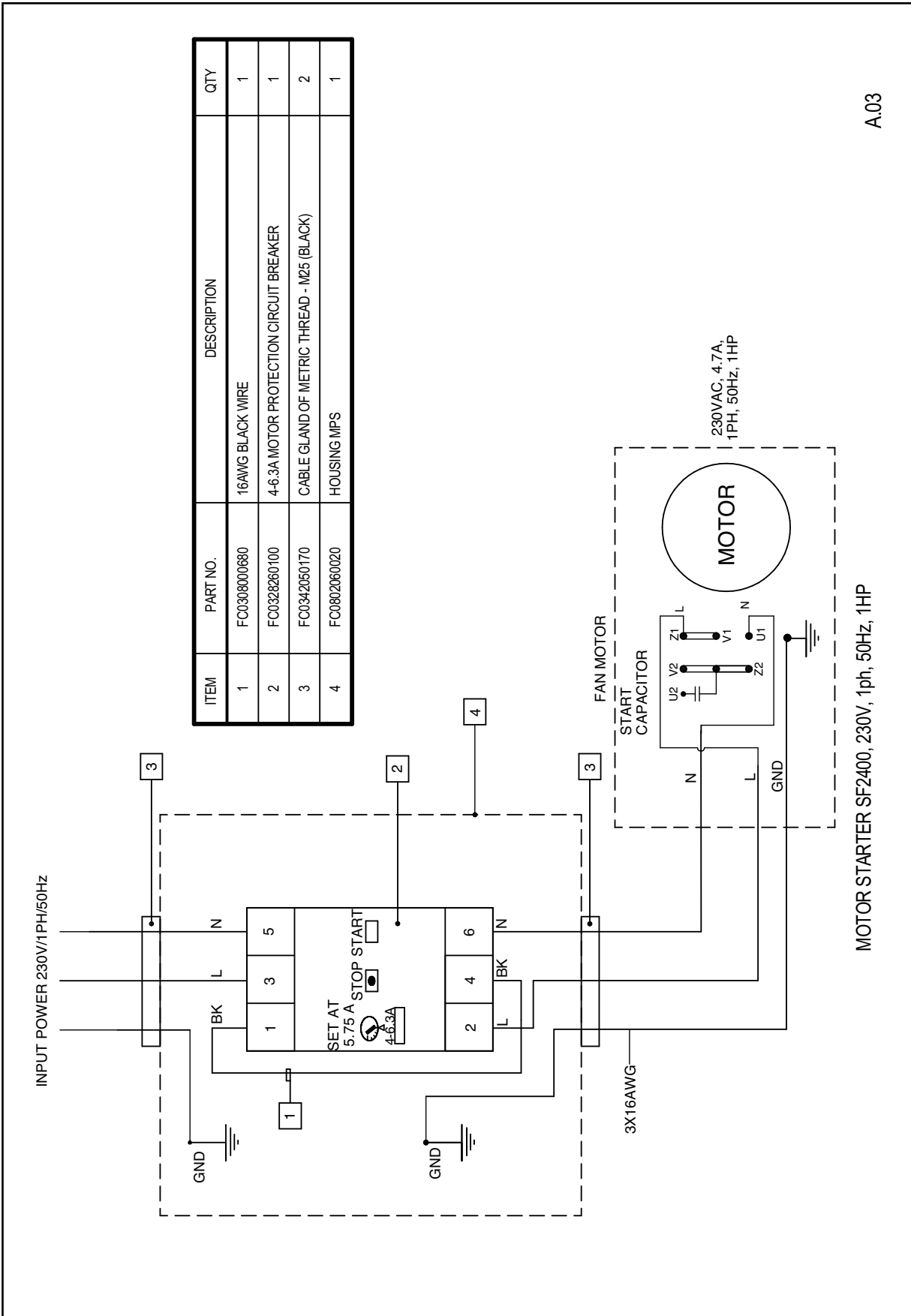
**WWW.LINCOLNELECTRIC.COM/LOCATOR**



ITEM	PART NO.	DESCRIPTION	QTY
1	FC0308000680	16AWG BLACK WIRE	1
2	FC0328260200	10-16A MOTOR PROTECTION CIRCUIT BREAKER	1
3	FC0342050170	CABLE GLAND OF METRIC THREAD - M25 (BLACK)	2
4	FC0802060020	HOUSING MPS	1

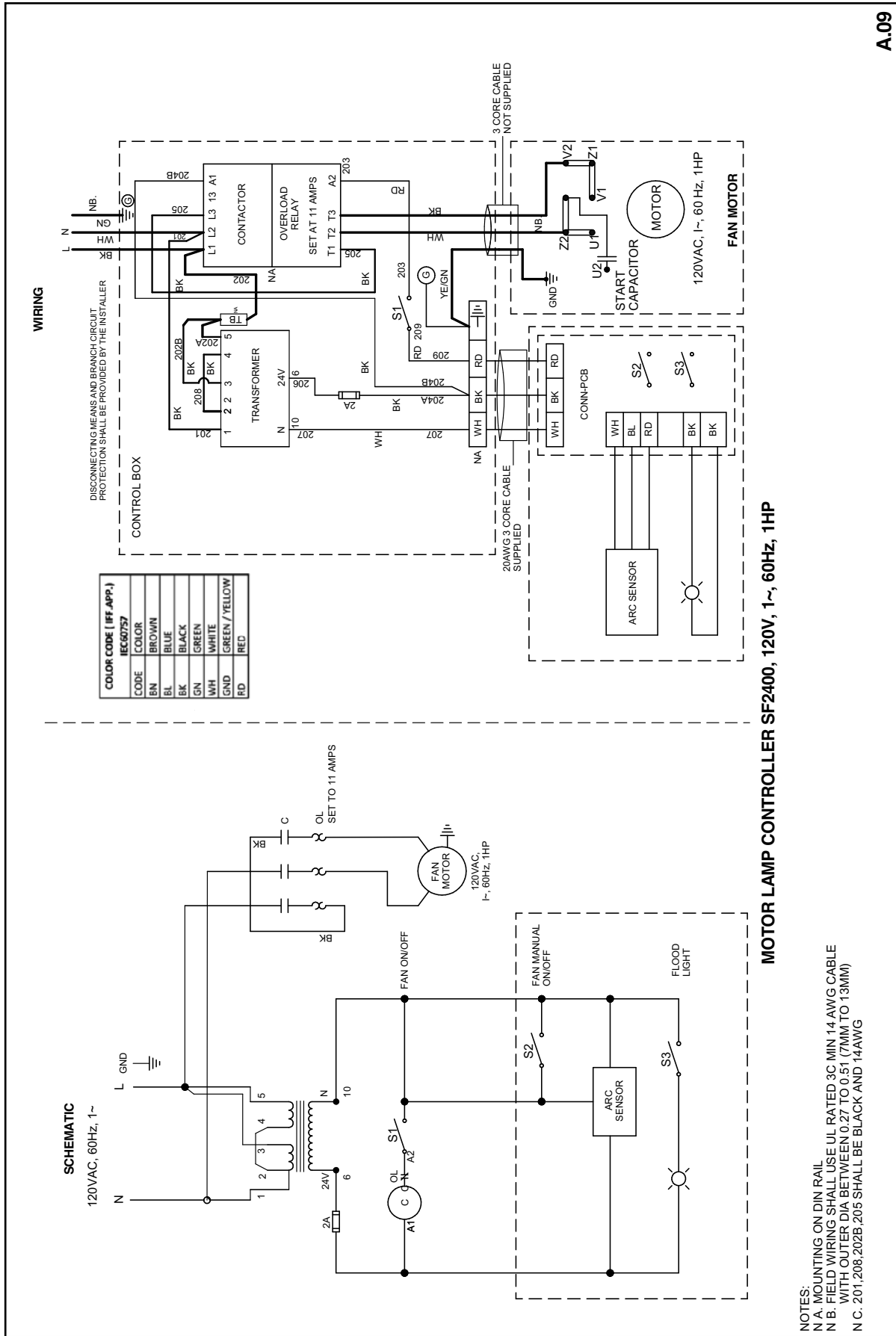


NOTE: This diagram is for reference only. It may not be accurate for all machines covered by this manual. The specific diagram for a particular code is pasted inside the machine on one of the enclosure panels. If the diagram is illegible, write to the Service Department for a replacement. Give the equipment code number.



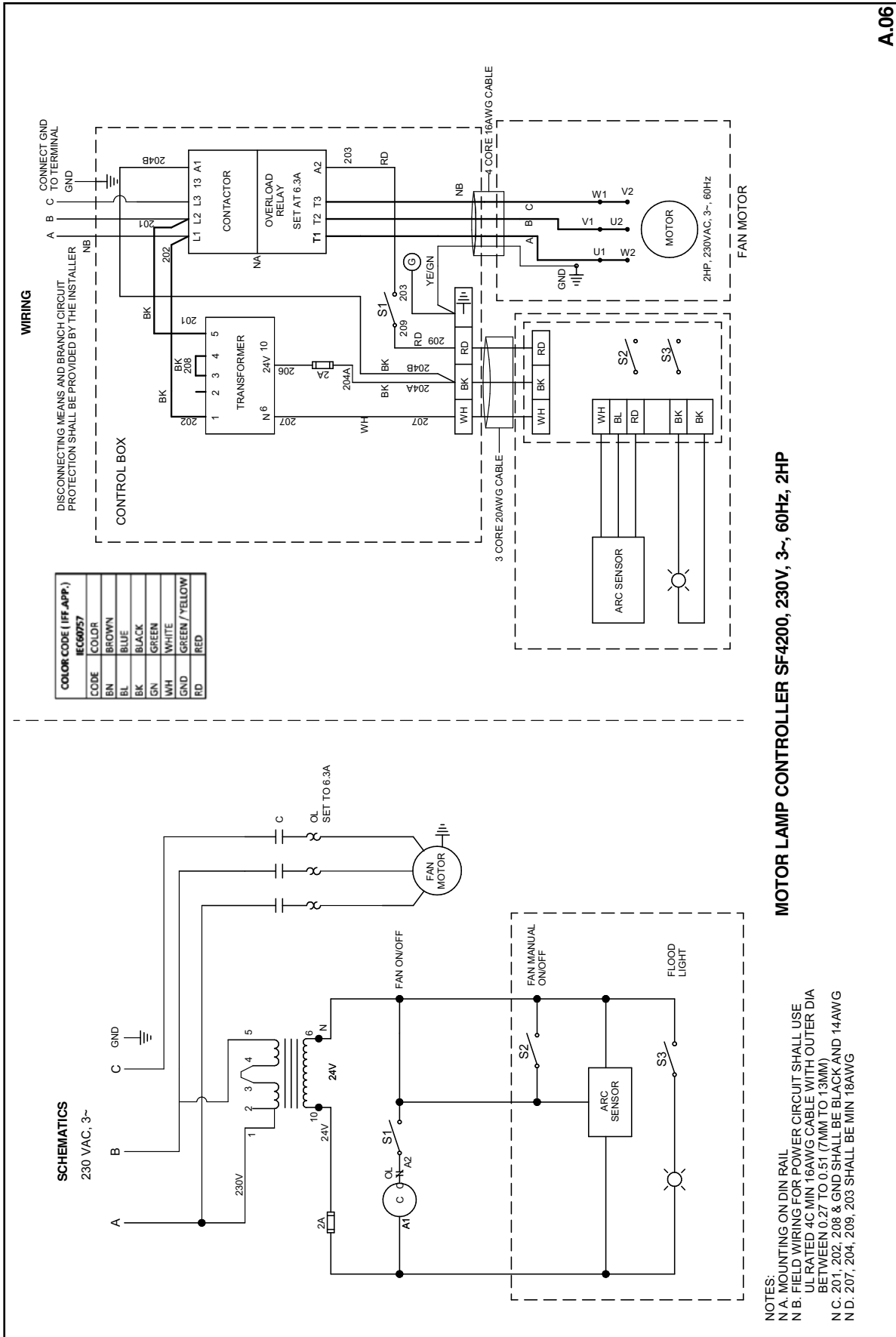
A.03

NOTE: This diagram is for reference only. It may not be accurate for all machines covered by this manual. The specific diagram for a particular code is pasted inside the machine on one of the enclosure panels. If the diagram is illegible, write to the Service Department for a replacement. Give the equipment code number.



A.09

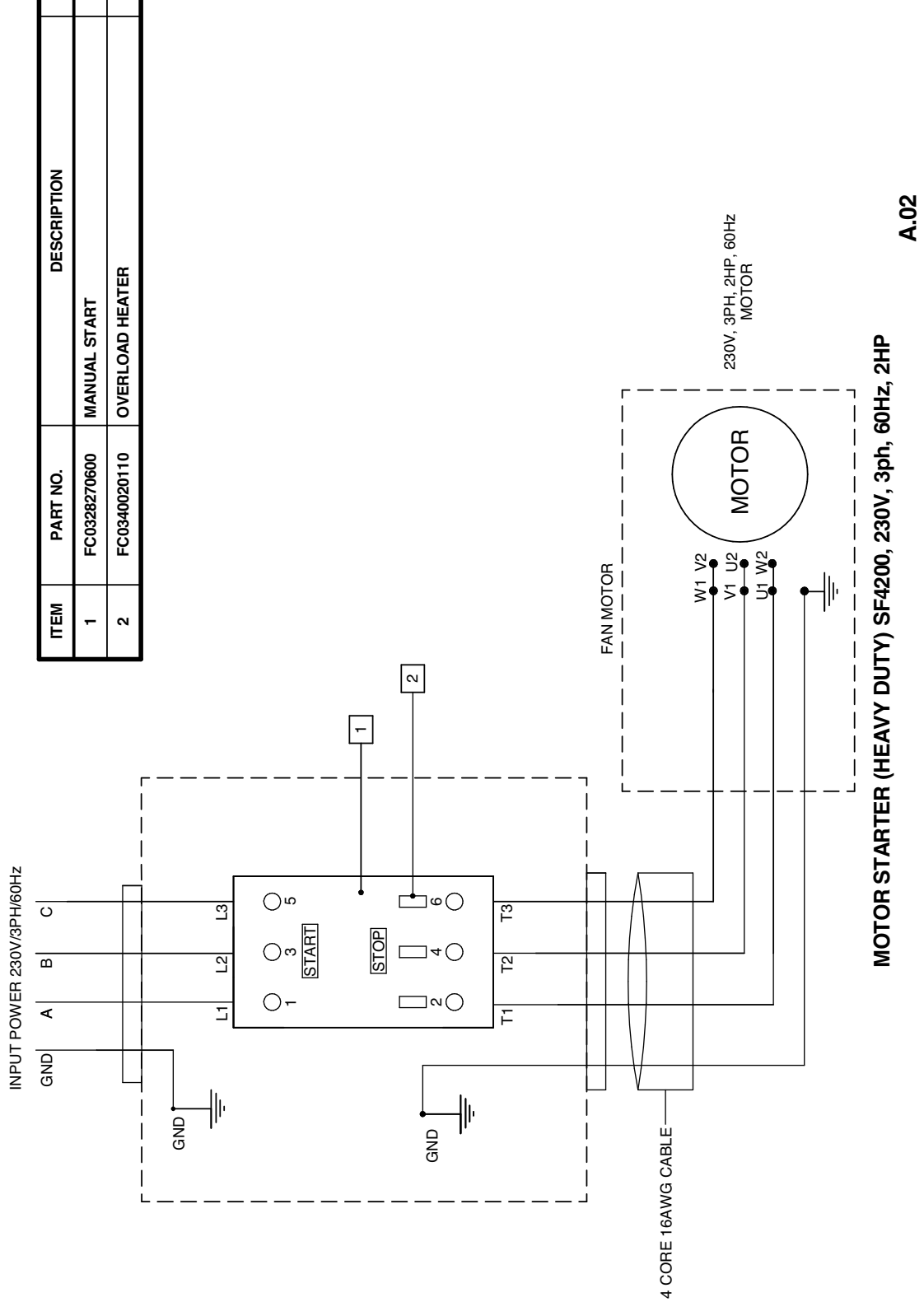
**NOTE:** This diagram is for reference only. It may not be accurate for all machines covered by this manual. The specific diagram for a particular code is pasted inside the machine on one of the enclosure panels. If the diagram is illegible, write to the Service Department for a replacement. Give the equipment code number.



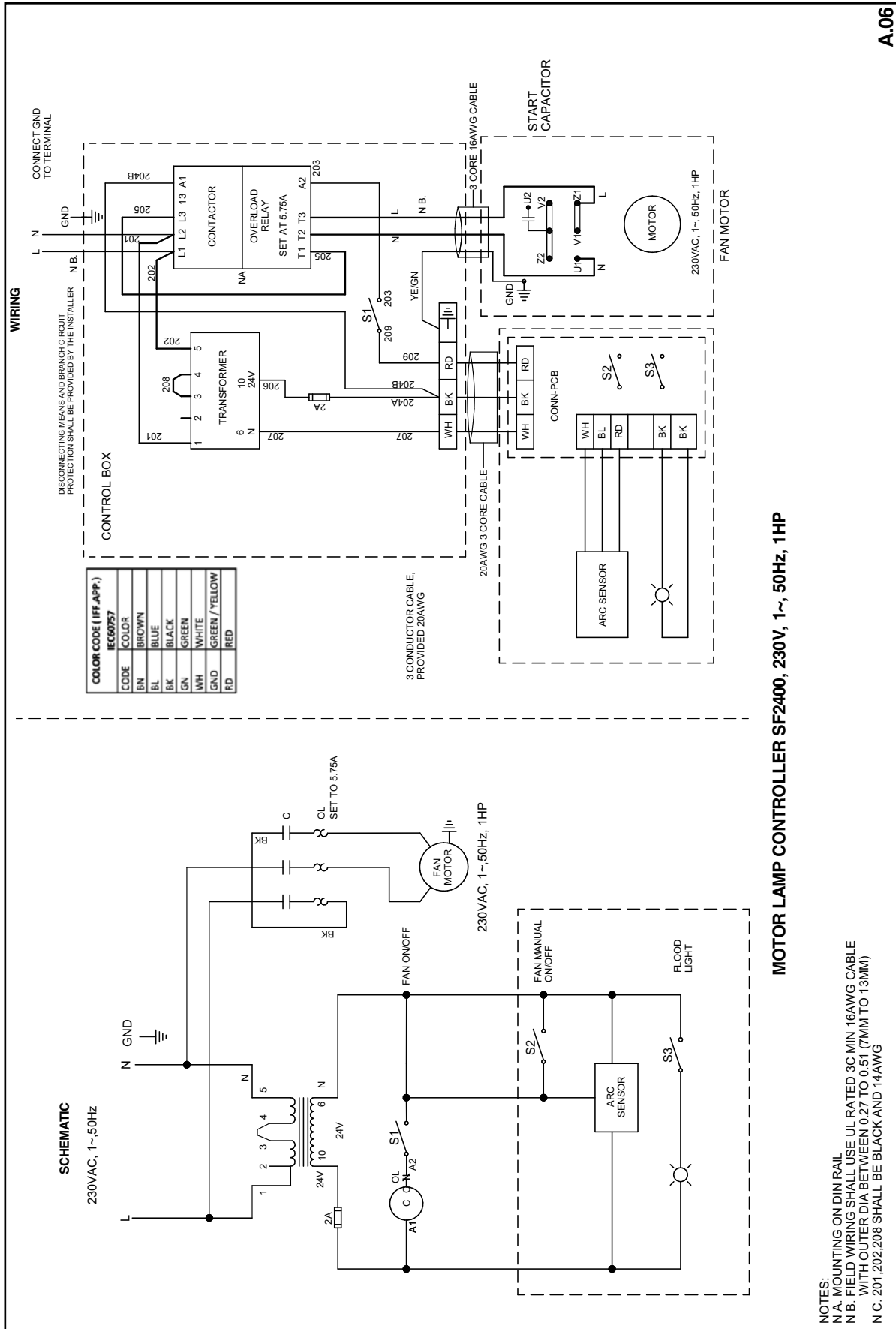
**NOTE:** This diagram is for reference only. It may not be accurate for all machines covered by this manual. The specific diagram for a particular code is pasted inside the machine on one of the enclosure panels. If the diagram is illegible, write to the Service Department for a replacement. Give the equipment code number.

A.06

ITEM	PART NO.	DESCRIPTION	QTY
1	FC0328270600	MANUAL START	1
2	FC0340020110	OVERLOAD HEATER	3



NOTE: This diagram is for reference only. It may not be accurate for all machines covered by this manual. The specific diagram for a particular code is pasted inside the machine on one of the enclosure panels. If the diagram is illegible, write to the Service Department for a replacement. Give the equipment code number.

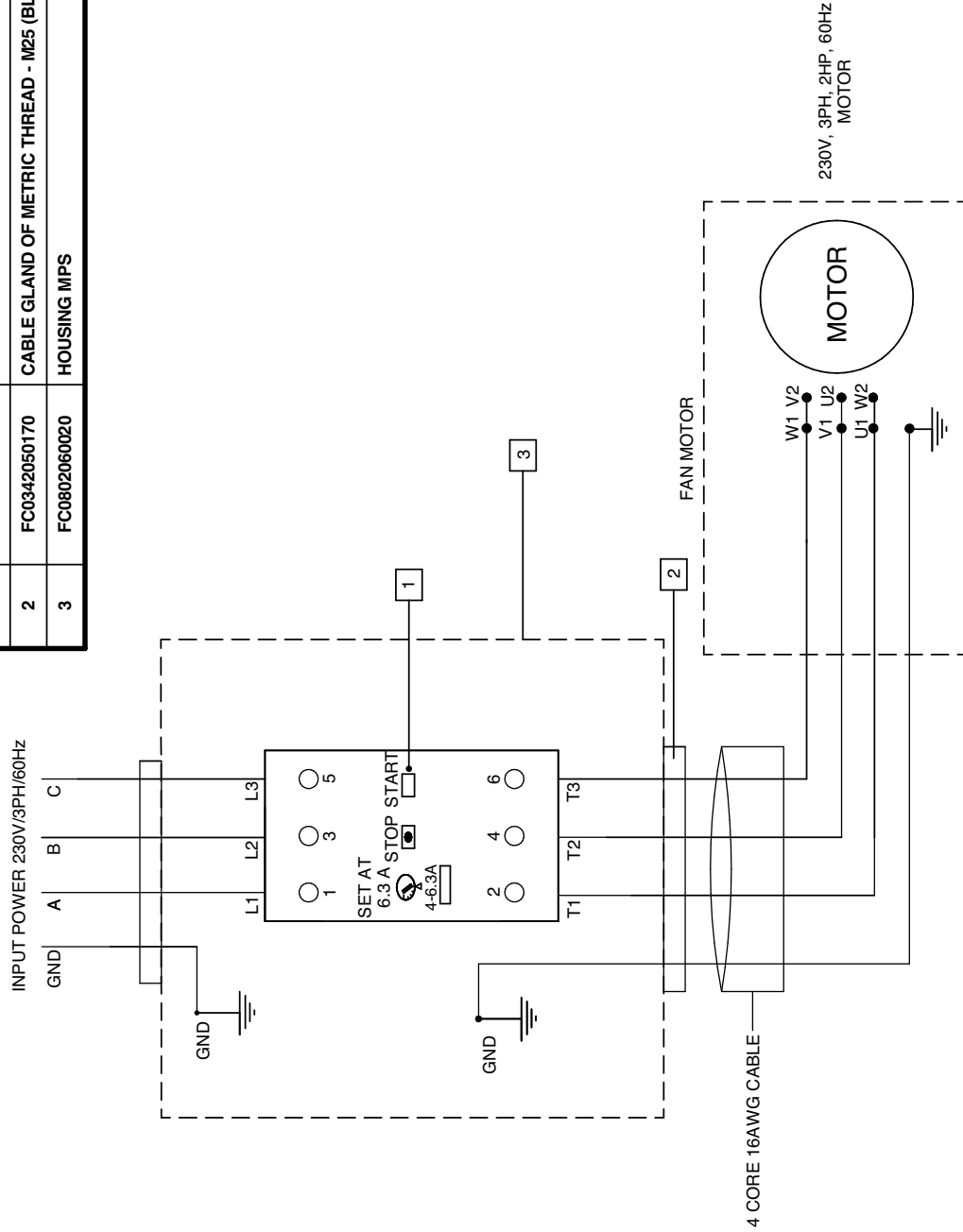


A.06

MOTOR LAMP CONTROLLER SF2400, 230V, 1~, 50Hz, 1HP

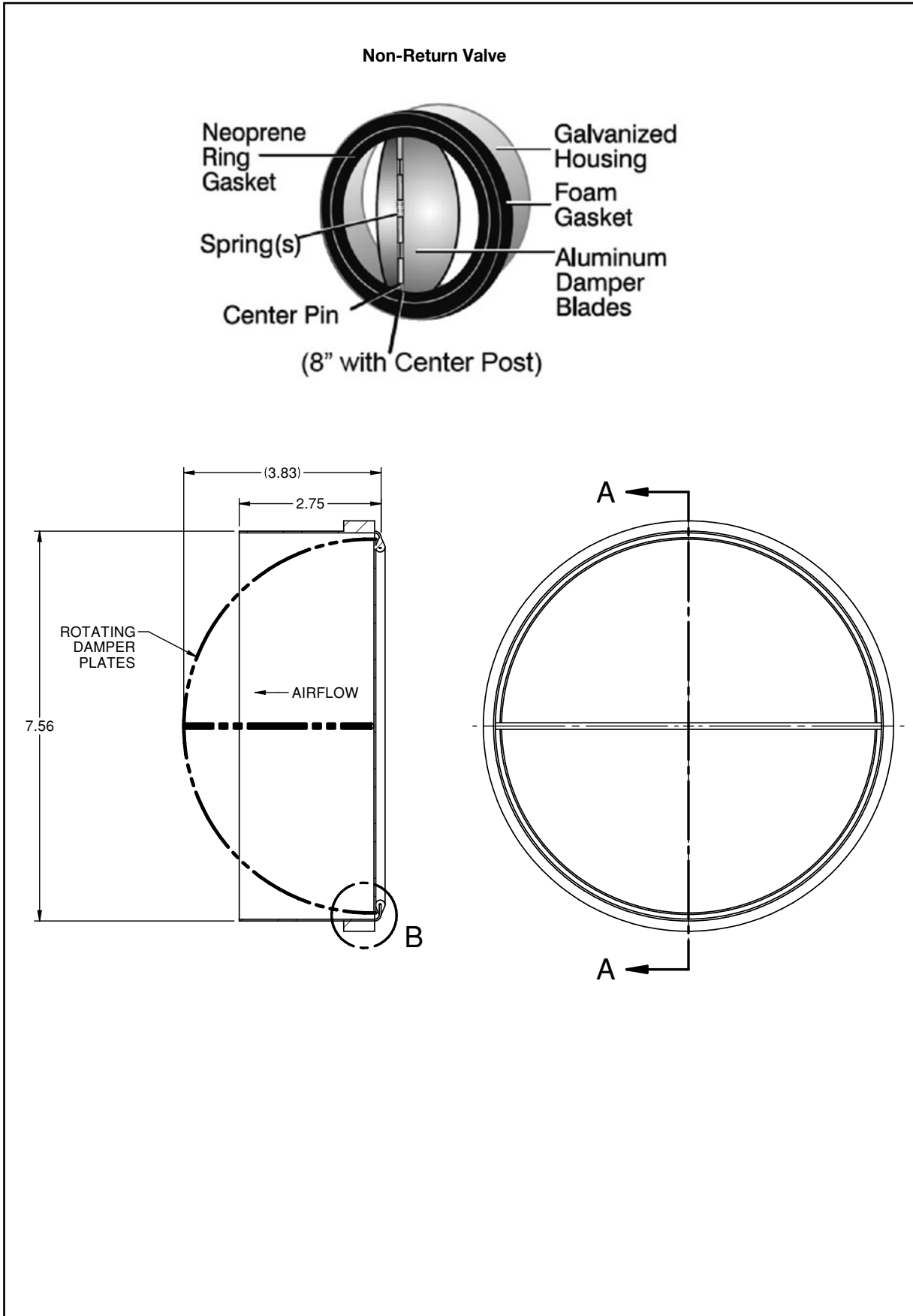
NOTE: This diagram is for reference only. It may not be accurate for all machines covered by this manual. The specific diagram for a particular code is pasted inside the machine on one of the enclosure panels. If the diagram is illegible, write to the Service Department for a replacement. Give the equipment code number.

ITEM	PART NO.	DESCRIPTION	QTY
1	FC0328260100	4-6.3A MOTOR PROTECTION CIRCUIT BREAKER	1
2	FC0342050170	CABLE GLAND OF METRIC THREAD - M25 (BLACK)	2
3	FC0802060020	HOUSING MPS	1



MOTOR STARTER SF4200, 230V, 3ph, 60Hz, 2HP A.02

NOTE: This diagram is for reference only. It may not be accurate for all machines covered by this manual. The specific diagram for a particular code is pasted inside the machine on one of the enclosure panels. If the diagram is illegible, write to the Service Department for a replacement. Give the equipment code number.



NOTE: This diagram is for reference only. It may not be accurate for all machines covered by this manual. The specific diagram for a particular code is pasted inside the machine on one of the enclosure panels. If the diagram is illegible, write to the Service Department for a replacement. Give the equipment code number.



THIS PAGE INTENTIONALLY LEFT BLANK



Service Navigator 2.0

# **Statiflex 200-M Single Arm Base Unit - K1654-4**

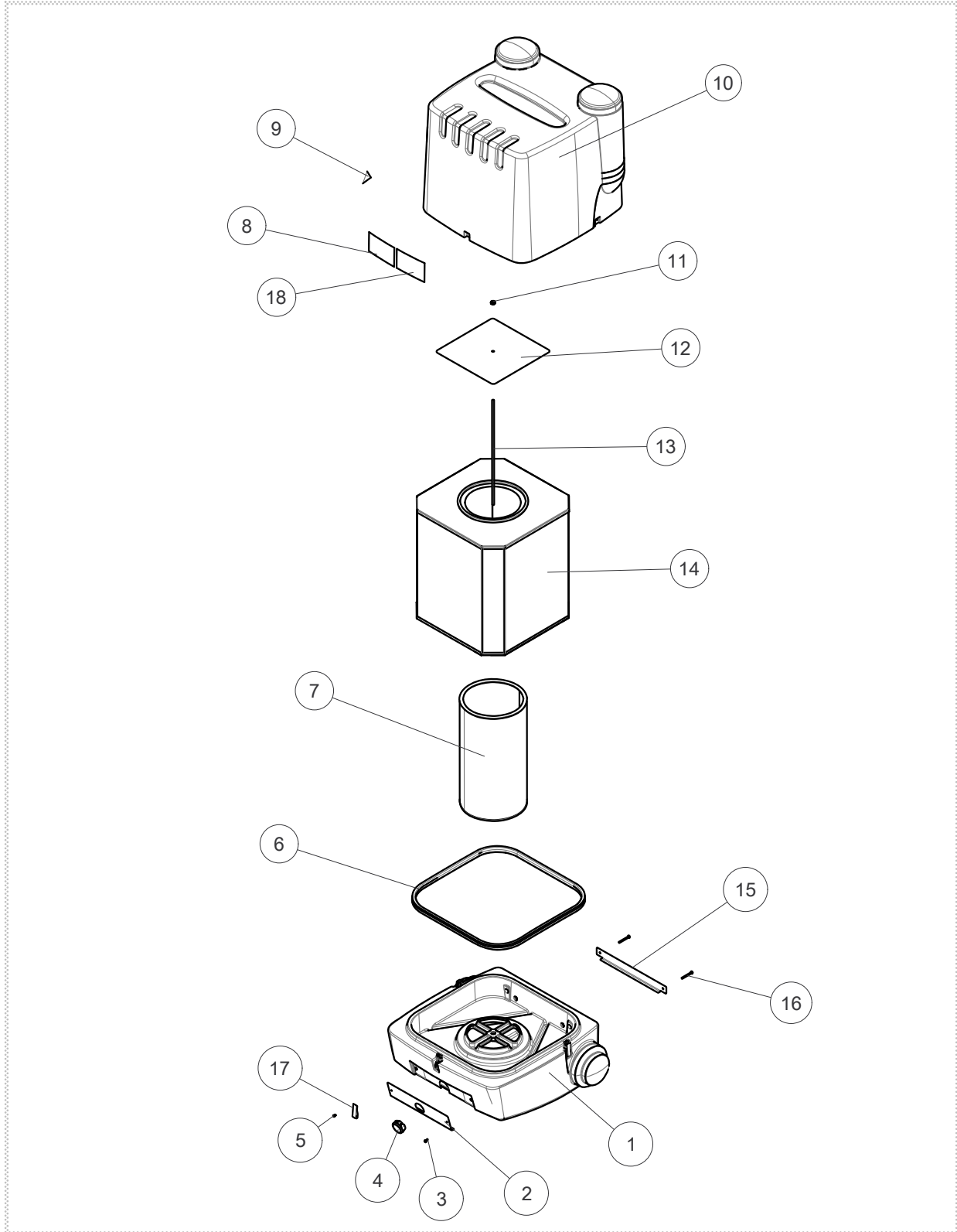
## Miscellaneous Items

KEY	PART NUMBER	DESCRIPTION	QTY
	9SS10888-47	HOSE CLAMP 8"	2
	9SS31256-7	FLEXIBLE DUCT	1
	9SFC0711010460	BRACKET WALL MOUNTING	1
	9SFC0401102050	SEALING RING	1
	9SFC0717030180	REDUCER	1

## General Assembly

KEY	PART NUMBER	DESCRIPTION	QTY
1	9SS31225-1	BASE	1
2	9SS31225-13	PLATE GAUGE MOUNT	1
3	9SS8025-91	SELF TAPPING SCREW	2
4	9SS31225-15	AIR PRESSURE GAUGE	1
5	9SS25930-10	#8-32 X .38 TORX BUTTON HEAD SCREW	15
6	9SS31225-10	GASKET	1
7	KP1673-5	SPARK ARRESTOR 200-M	1
8	9SM22196	DECAL WARNING ENGLISH	1
9	9SS31224-39	DECAL SAFETY SIGN FIRE	1
10	9SS31225-3	LID	1
11	9SS31225-4	NUT THUMB 3/8-16	1
12	9SFC0710060030	PLATE FILTER RETAINING	1
13	9SS31225-5	ROD THREADED FILTER RETAINING	1
14	KP1673-1	FILTER 200-M	1
15	9SFC0704090030	PLATE REINFORCING	1
16	9ST14731-105	M6 X 60	2
17	9SS31223-5	DRAW LATCH	3
18	9SM22196-1	DECAL WARNING FRENCH	1
	9SS31225-14	STATIFLEX ROTATIONAL MOLDED KIT	1
	9ST10642-362	FLEX TUBE	1

# Statiflex 200-M Single Arm Base Unit - K1654-4 General Assembly



P-948-C.jpg

# **Statiflex 200-M Dual Arm, 8 In Hose Kit - K1654-5**

## Miscellaneous Items

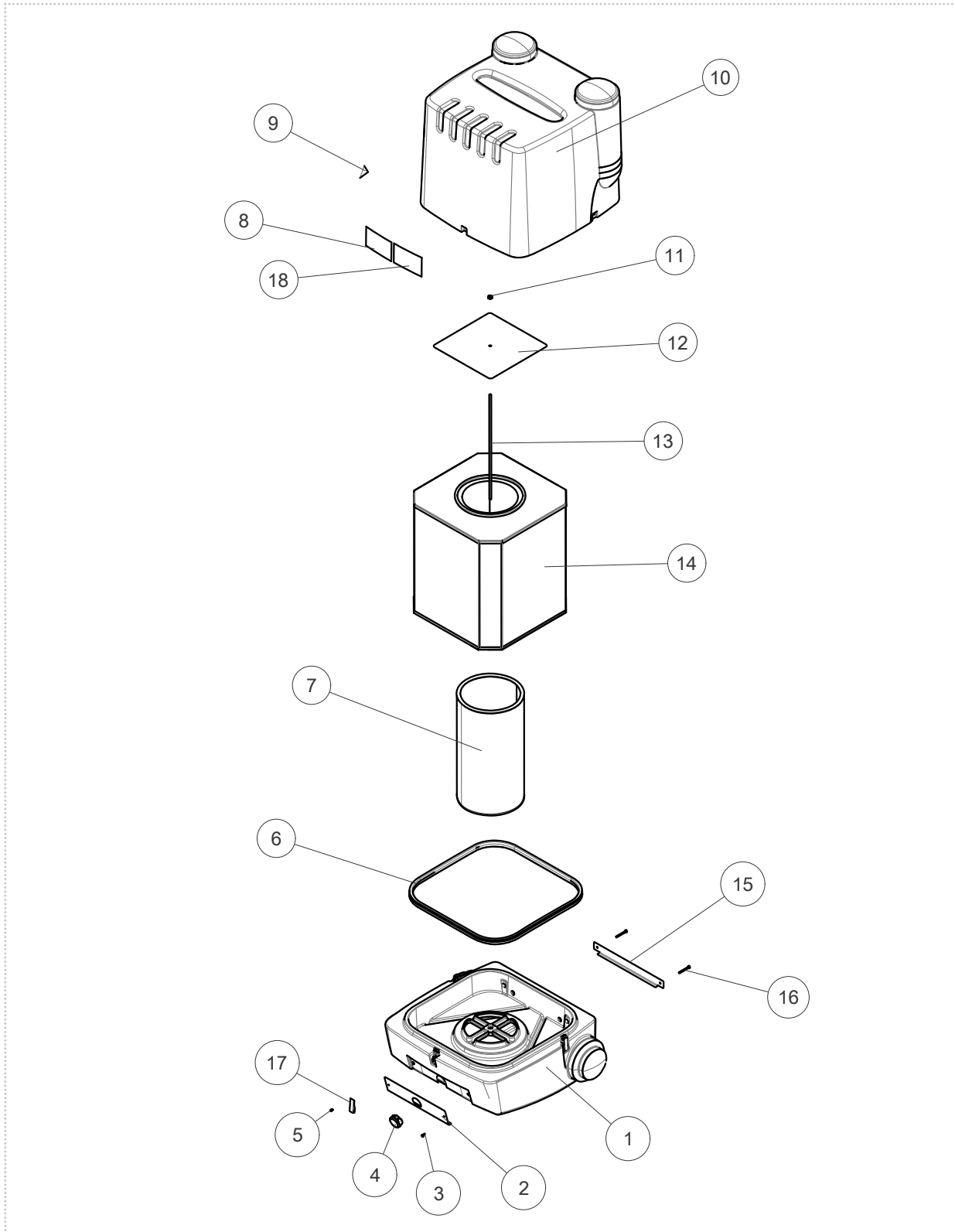
KEY	PART NUMBER	DESCRIPTION	QTY
	9SS10888-47	HOSE CLAMP 8"	4
	9SS31256-7	FLEXIBLE DUCT	2
	9SFC0711010460	BRACKET WALL MOUNTING	1
	9SFC0401102050	SEALING RING	2
	9SFC0042021060	NON-RETURN VALVE	2
	9SFC0717030180	REDUCER	2

## General Assembly

KEY	PART NUMBER	DESCRIPTION	QTY
1	9SS31225-1	BASE	1
2	9SS31225-13	PLATE GAUGE MOUNT	1
3	9SS8025-91	SELF TAPPING SCREW	2
4	9SS31225-15	AIR PRESSURE GAUGE	1
5	9SS25930-10	#8-32 X .38 TORX BUTTON HEAD SCREW	15
6	9SS31225-10	GASKET	1
7	KP1673-5	SPARK ARRESTOR 200-M	1
8	9SM22196	DECAL WARNING ENGLISH	1
9	9SS31224-39	DECAL SAFETY SIGN FIRE	1
10	9SS31225-3	LID	1
11	9SS31225-4	NUT THUMB 3/8-16	1
12	9SFC0710060030	PLATE FILTER RETAINING	1
13	9SS31225-5	ROD THREADED FILTER RETAINING	1
14	KP1673-1	FILTER 200-M	1
15	9SFC0704090030	PLATE REINFORCING	1
16	9ST14731-105	M6 X 60	2
17	9SS31223-5	DRAW LATCH	3
18	9SM22196-1	DECAL WARNING FRENCH	1
	9ST10642-362	FLEX TUBE	1
	9SS31225-14	STATIFLEX ROTATIONAL MOLDED KIT	1



# Statiflex 200-M Dual Arm, 8 In Hose Kit - K1654-5 General Assembly



P-949-C.jpg

# **Statiflex 200-M Hi Efficiency Single Arm - K1654-6**

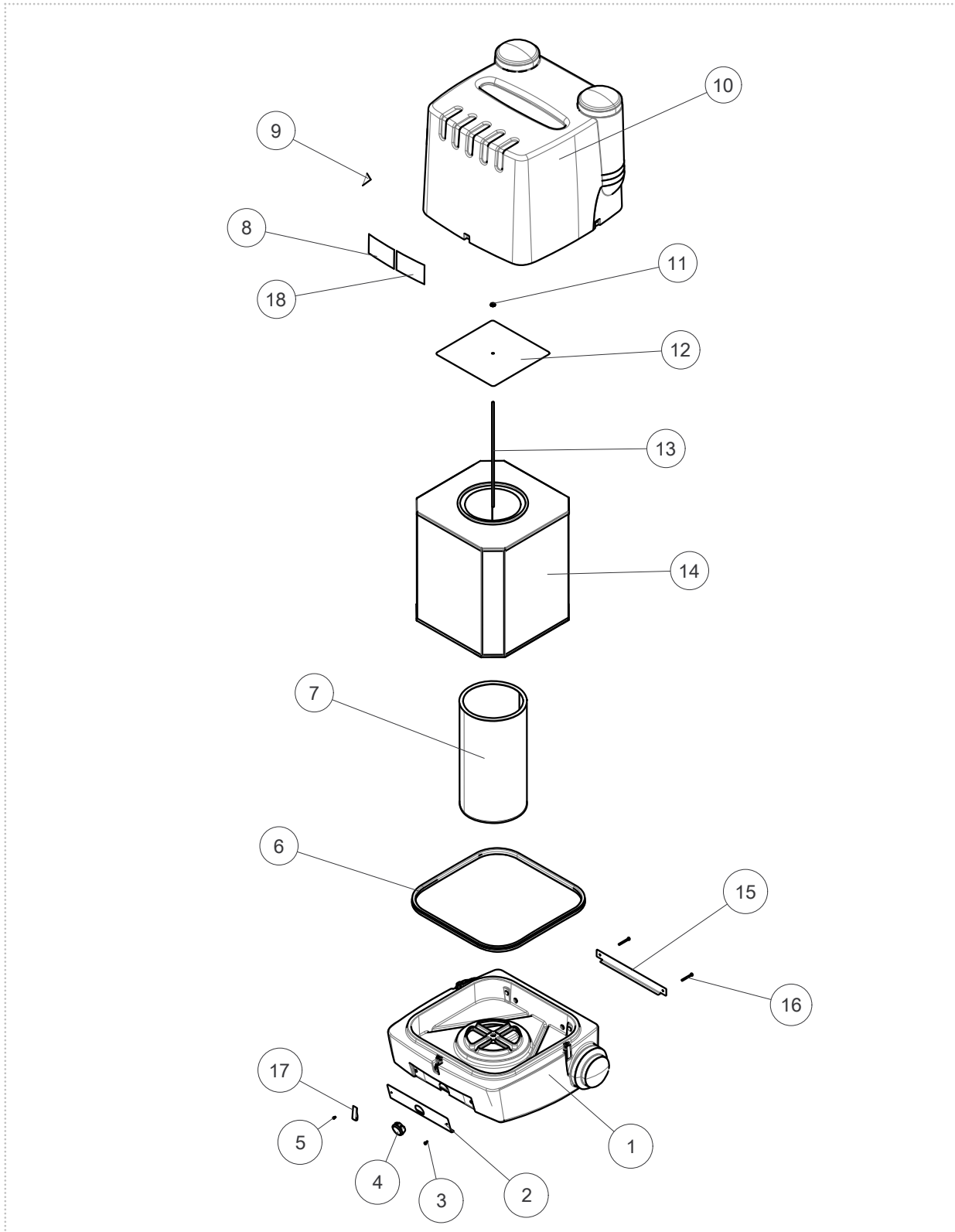
## Miscellaneous Items

KEY	PART NUMBER	DESCRIPTION	QTY
	9SS10888-47	HOSE CLAMP 8"	2
	9SS31256-7	FLEXIBLE DUCT	1
	9SFC0711010460	BRACKET WALL MOUNTING	1
	9SFC0401102050	SEALING RING	1
	9SFC0717030180	REDUCER	1

## Statiflex 200-M Hi Efficiency Single Arm - K1654-6 General Assembly

KEY	PART NUMBER	DESCRIPTION	QTY
1	9SS31225-1	BASE	1
2	9SS31225-13	PLATE GAUGE MOUNT	1
3	9SS8025-91	SELF TAPPING SCREW	2
4	9SS31225-15	AIR PRESSURE GAUGE	1
5	9SS25930-10	#8-32 X .38 TORX BUTTON HEAD SCREW	15
6	9SS31225-10	GASKET	1
7	KP1673-5	SPARK ARRESTER 200-M	1
8	9SM22196	DECAL WARNING ENGLISH	1
9	9SS31224-39	DECAL SAFETY SIGN FIRE	1
10	9SS31225-3	LID	1
11	9SS31225-4	NUT THUMB 3/8-16	1
12	9SFC0710060030	PLATE FILTER RETAINING	1
13	9SS31225-5	ROD THREADED FILTER RETAINING	1
14	KP1673-9	MERV 16, Nano Filter for Mobiflex/Statiflex	1
15	9SFC0704090030	PLATE REINFORCING	1
16	9ST14731-105	M6 X 60	2
17	9SS31223-5	DRAW LATCH	3
18	9SM22196-1	DECAL WARNING FRENCH	1
	9ST10642-362	FLEX TUBE	1
	9SS31225-14	STATIFLEX ROTATIONAL MOLDED KIT	1

# Statiflex 200-M Hi Efficiency Single Arm - K1654-6 General Assembly



P-950-C.jpg

			
<b>WARNING</b>	<ul style="list-style-type: none"> <li>● Do not touch electrically live parts or electrode with skin or wet clothing.</li> <li>● Insulate yourself from work and ground.</li> </ul>	<ul style="list-style-type: none"> <li>● Keep flammable materials away.</li> </ul>	<ul style="list-style-type: none"> <li>● Wear eye, ear and body protection.</li> </ul>
Spanish <b>AVISO DE PRECAUCION</b>	<ul style="list-style-type: none"> <li>● No toque las partes o los electrodos bajo carga con la piel o ropa mojada.</li> <li>● Aíslese del trabajo y de la tierra.</li> </ul>	<ul style="list-style-type: none"> <li>● Mantenga el material combustible fuera del área de trabajo.</li> </ul>	<ul style="list-style-type: none"> <li>● Protéjase los ojos, los oídos y el cuerpo.</li> </ul>
French <b>ATTENTION</b>	<ul style="list-style-type: none"> <li>● Ne laissez ni la peau ni des vêtements mouillés entrer en contact avec des pièces sous tension.</li> <li>● Isolez-vous du travail et de la terre.</li> </ul>	<ul style="list-style-type: none"> <li>● Gardez à l'écart de tout matériel inflammable.</li> </ul>	<ul style="list-style-type: none"> <li>● Protégez vos yeux, vos oreilles et votre corps.</li> </ul>
German <b>WARNUNG</b>	<ul style="list-style-type: none"> <li>● Berühren Sie keine stromführenden Teile oder Elektroden mit Ihrem Körper oder feuchter Kleidung!</li> <li>● Isolieren Sie sich von den Elektroden und dem Erdboden!</li> </ul>	<ul style="list-style-type: none"> <li>● Entfernen Sie brennbares Material!</li> </ul>	<ul style="list-style-type: none"> <li>● Tragen Sie Augen-, Ohren- und Körperschutz!</li> </ul>
Portuguese <b>ATENÇÃO</b>	<ul style="list-style-type: none"> <li>● Não toque partes elétricas e electrodos com a pele ou roupa molhada.</li> <li>● Isole-se da peça e terra.</li> </ul>	<ul style="list-style-type: none"> <li>● Mantenha inflamáveis bem guardados.</li> </ul>	<ul style="list-style-type: none"> <li>● Use proteção para a vista, ouvido e corpo.</li> </ul>
Japanese <b>注意事項</b>	<ul style="list-style-type: none"> <li>● 通電中の電気部品、又は溶材にヒフやぬれた布で触れないこと。</li> <li>● 施工物やアースから身体が絶縁されている様にして下さい。</li> </ul>	<ul style="list-style-type: none"> <li>● 燃えやすいものの側での溶接作業は絶対にしてはなりません。</li> </ul>	<ul style="list-style-type: none"> <li>● 目、耳及び身体に保護具をして下さい。</li> </ul>
Chinese <b>警告</b>	<ul style="list-style-type: none"> <li>● 皮肤或濕衣物切勿接觸帶電部件及鎢條。</li> <li>● 使你自已與地面和工件絕緣。</li> </ul>	<ul style="list-style-type: none"> <li>● 把一切易燃物品移離工作場所。</li> </ul>	<ul style="list-style-type: none"> <li>● 佩戴眼、耳及身體勞動保護用具。</li> </ul>
Korean <b>위험</b>	<ul style="list-style-type: none"> <li>● 전도체나 용접봉을 젖은 헝겍 또는 피부로 절대 접촉치 마십시오.</li> <li>● 모재와 접지를 접촉치 마십시오.</li> </ul>	<ul style="list-style-type: none"> <li>● 인화성 물질을 접근시키지 마십시오.</li> </ul>	<ul style="list-style-type: none"> <li>● 눈, 귀와 몸에 보호장구를 착용하십시오.</li> </ul>
Arabic <b>تحذير</b>	<ul style="list-style-type: none"> <li>● لا تلمس الاجزاء التي يسري فيها التيار الكهربائي أو الالكترود بجسد الجسم أو بالملابس المبللة بالماء.</li> <li>● ضع عازلا على جسمك خلال العمل.</li> </ul>	<ul style="list-style-type: none"> <li>● ضع المواد القابلة للاشتعال في مكان بعيد.</li> </ul>	<ul style="list-style-type: none"> <li>● ضع أدوات وملابس واقية على عينيك وأذنيك وجسمك.</li> </ul>

**READ AND UNDERSTAND THE MANUFACTURER'S INSTRUCTION FOR THIS EQUIPMENT AND THE CONSUMABLES TO BE USED AND FOLLOW YOUR EMPLOYER'S SAFETY PRACTICES.**

**SE RECOMIENDA LEER Y ENTENDER LAS INSTRUCCIONES DEL FABRICANTE PARA EL USO DE ESTE EQUIPO Y LOS CONSUMIBLES QUE VA A UTILIZAR, SIGA LAS MEDIDAS DE SEGURIDAD DE SU SUPERVISOR.**

**LISEZ ET COMPRENEZ LES INSTRUCTIONS DU FABRICANT EN CE QUI REGARDE CET EQUIPMENT ET LES PRODUITS A ETRE EMPLOYES ET SUIVEZ LES PROCEDURES DE SECURITE DE VOTRE EMPLOYEUR.**

**LESEN SIE UND BEFOLGEN SIE DIE BETRIEBSANLEITUNG DER ANLAGE UND DEN ELEKTRODENEINSATZ DES HERSTELLERS. DIE UNFALLVERHÜTUNGSVORSCHRIFTEN DES ARBEITGEBERS SIND EBENFALLS ZU BEACHTEN.**

			
<ul style="list-style-type: none"> <li>● Keep your head out of fumes.</li> <li>● Use ventilation or exhaust to remove fumes from breathing zone.</li> </ul>	<ul style="list-style-type: none"> <li>● Turn power off before servicing.</li> </ul>	<ul style="list-style-type: none"> <li>● Do not operate with panel open or guards off.</li> </ul>	<b>WARNING</b>
<ul style="list-style-type: none"> <li>● Los humos fuera de la zona de respiración.</li> <li>● Mantenga la cabeza fuera de los humos. Utilice ventilación o aspiración para gases.</li> </ul>	<ul style="list-style-type: none"> <li>● Desconectar el cable de alimentación de poder de la máquina antes de iniciar cualquier servicio.</li> </ul>	<ul style="list-style-type: none"> <li>● No operar con panel abierto o guardas quitadas.</li> </ul>	Spanish <b>AVISO DE PRECAUCION</b>
<ul style="list-style-type: none"> <li>● Gardez la tête à l'écart des fumées.</li> <li>● Utilisez un ventilateur ou un aspirateur pour ôter les fumées des zones de travail.</li> </ul>	<ul style="list-style-type: none"> <li>● Débranchez le courant avant l'entretien.</li> </ul>	<ul style="list-style-type: none"> <li>● N'opérez pas avec les panneaux ouverts ou avec les dispositifs de protection enlevés.</li> </ul>	French <b>ATTENTION</b>
<ul style="list-style-type: none"> <li>● Vermeiden Sie das Einatmen von Schweißrauch!</li> <li>● Sorgen Sie für gute Be- und Entlüftung des Arbeitsplatzes!</li> </ul>	<ul style="list-style-type: none"> <li>● Strom vor Wartungsarbeiten abschalten! (Netzstrom völlig öffnen; Maschine anhalten!)</li> </ul>	<ul style="list-style-type: none"> <li>● Anlage nie ohne Schutzgehäuse oder Innenschutzverkleidung in Betrieb setzen!</li> </ul>	German <b>WARNUNG</b>
<ul style="list-style-type: none"> <li>● Mantenha seu rosto da fumaça.</li> <li>● Use ventilação e exaustão para remover fumo da zona respiratória.</li> </ul>	<ul style="list-style-type: none"> <li>● Não opere com as tampas removidas.</li> <li>● Desligue a corrente antes de fazer serviço.</li> <li>● Não toque as partes elétricas nuas.</li> </ul>	<ul style="list-style-type: none"> <li>● Mantenha-se afastado das partes moventes.</li> <li>● Não opere com os painéis abertos ou guardas removidas.</li> </ul>	Portuguese <b>ATENÇÃO</b>
<ul style="list-style-type: none"> <li>● ヒュームから頭を離すようにして下さい。</li> <li>● 換気や排煙に十分留意して下さい。</li> </ul>	<ul style="list-style-type: none"> <li>● メンテナンス・サービスに取りかかる際には、まず電源スイッチを必ず切して下さい。</li> </ul>	<ul style="list-style-type: none"> <li>● パネルやカバーを取り外したままで機械操作をしないで下さい。</li> </ul>	Japanese <b>注意事項</b>
<ul style="list-style-type: none"> <li>● 頭部遠離煙霧。</li> <li>● 在呼吸區使用通風或排風器除煙。</li> </ul>	<ul style="list-style-type: none"> <li>● 維修前切斷電源。</li> </ul>	<ul style="list-style-type: none"> <li>● 儀表板打開或沒有安全罩時不準作業。</li> </ul>	Chinese <b>警告</b>
<ul style="list-style-type: none"> <li>● 얼굴로부터 용접가스를 멀리하십시오.</li> <li>● 호흡지역으로부터 용접가스를 제거하기 위해 가스제거기나 통풍기를 사용하십시오.</li> </ul>	<ul style="list-style-type: none"> <li>● 보수전에 전원을 차단하십시오.</li> </ul>	<ul style="list-style-type: none"> <li>● 관널이 열린 상태로 작동치 마십시오.</li> </ul>	Korean <b>위험</b>
<ul style="list-style-type: none"> <li>● ابعد رأسك بعيداً عن الدخان.</li> <li>● استعمل التهوية أو جهاز ضغط الدخان للخارج لكي تبعد الدخان عن المنطقة التي تتنفس فيها.</li> </ul>	<ul style="list-style-type: none"> <li>● اقطع التيار الكهربائي قبل القيام بأية صيانة.</li> </ul>	<ul style="list-style-type: none"> <li>● لا تشغيل هذا الجهاز اذا كانت الاغطية الحديدية الواقية ليست عليه.</li> </ul>	Arabic <b>تحذير</b>

**LEIA E COMPREENDA AS INSTRUÇÕES DO FABRICANTE PARA ESTE EQUIPAMENTO E AS PARTES DE USO, E SIGA AS PRÁTICAS DE SEGURANÇA DO EMPREGADOR.**

使う機械や溶材のメーカーの指示書をよく読み、まず理解して下さい。そして貴社の安全規定に従って下さい。

請詳細閱讀並理解製造廠提供的說明以及應該使用的銀焊材料，並請遵守貴方的有關勞動保護規定。

이 제품에 동봉된 작업지침서를 숙지하시고 귀사의 작업자 안전수칙을 준수하시기 바랍니다.

اقرأ بتمعن وافهم تعليمات المصنع المنتج لهذه المعدات والمواد قبل استعمالها واتبع تعليمات الوقاية لصاحب العمل.

## **CUSTOMER ASSISTANCE POLICY**

The business of The Lincoln Electric Company is manufacturing and selling high quality welding equipment, consumables, and cutting equipment. Our challenge is to meet the needs of our customers and to exceed their expectations. On occasion, purchasers may ask Lincoln Electric for advice or information about their use of our products. We respond to our customers based on the best information in our possession at that time. Lincoln Electric is not in a position to warrant or guarantee such advice, and assumes no liability, with respect to such information or advice. We expressly disclaim any warranty of any kind, including any warranty of fitness for any customer's particular purpose, with respect to such information or advice. As a matter of practical consideration, we also cannot assume any responsibility for updating or correcting any such information or advice once it has been given, nor does the provision of information or advice create, expand or alter any warranty with respect to the sale of our products.

Lincoln Electric is a responsive manufacturer, but the selection and use of specific products sold by Lincoln Electric is solely within the control of, and remains the sole responsibility of the customer. Many variables beyond the control of Lincoln Electric affect the results obtained in applying these types of fabrication methods and service requirements.

Subject to Change – This information is accurate to the best of our knowledge at the time of printing. Please refer to [www.lincolnelectric.com](http://www.lincolnelectric.com) for any updated information.

## **WELD FUME CONTROL EQUIPMENT**

The operation of welding fume control equipment is affected by various factors including proper use and positioning of the equipment, maintenance of the equipment and the specific welding procedure and application involved. Worker exposure level should be checked upon installation and periodically thereafter to be certain it is within applicable OSHA PEL and ACGIH TLV limits.



### **THE LINCOLN ELECTRIC COMPANY**

22801 St. Clair Avenue • Cleveland, OH • 44117-1199 • U.S.A.  
Phone: +1.216.481.8100 • [www.lincolnelectric.com](http://www.lincolnelectric.com)