

VANTAGE 500 MACHINE SCHEMATIC G4848-1 REV: B

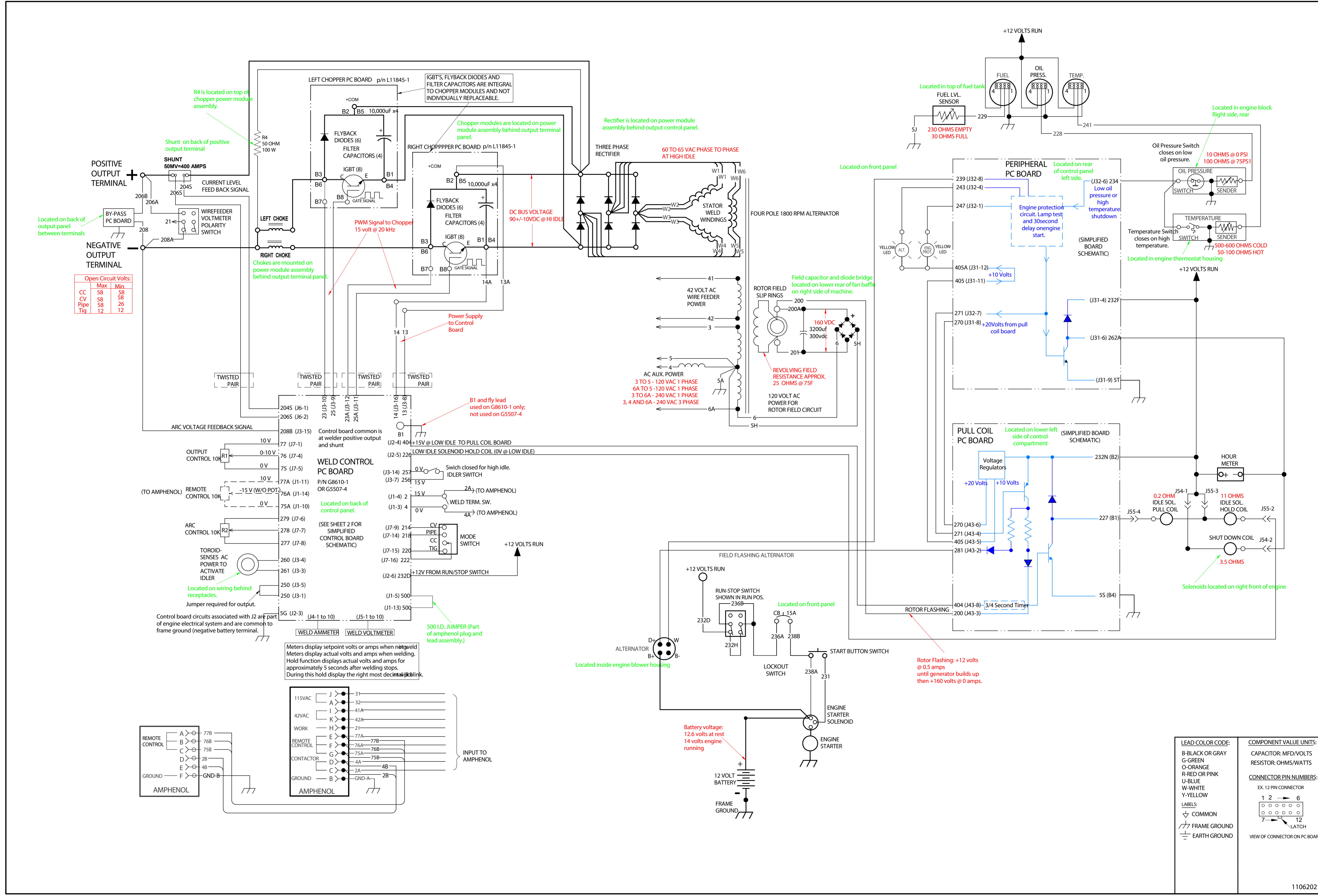

Open Circuit Volts:

	Max	Min
CC	58	58
CV	58	58
Pipe	58	26
Tig	12	12

Meters display setpoint volts or amps when not welding. Meters display actual volts and amps when welding. Hold function displays actual volts and amps for approximately 5 seconds after welding stops. During this hold display the right most decimal digit blinks.

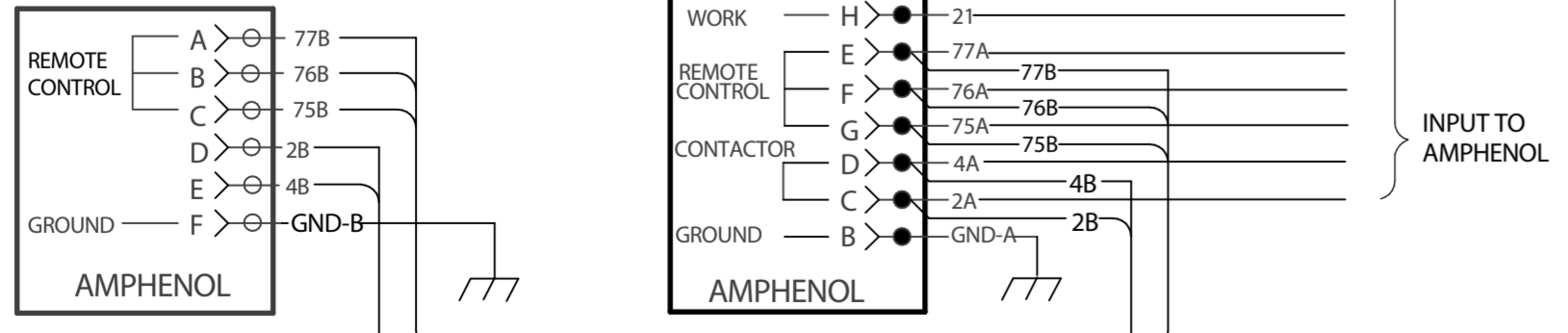

LEAD COLOR CODE:	COMPONENT VALUE UNITS:
B-BLACK OR GRAY	CAPACITOR: MFD/VOLTS
G-GREEN	RESISTOR: OHMS/WATTS
O-ORANGE	
R-RED OR PINK	
U-BLUE	CONNECTOR PIN NUMBERS:
W-WHITE	EX. 12 PIN CONNECTOR
Y-YELLOW	
LABELS:	
∇ COMMON	
⏏ FRAME GROUND	
⏏ EARTH GROUND	

SIMPLIFIED CONTROL BOARD SCHEMATIC

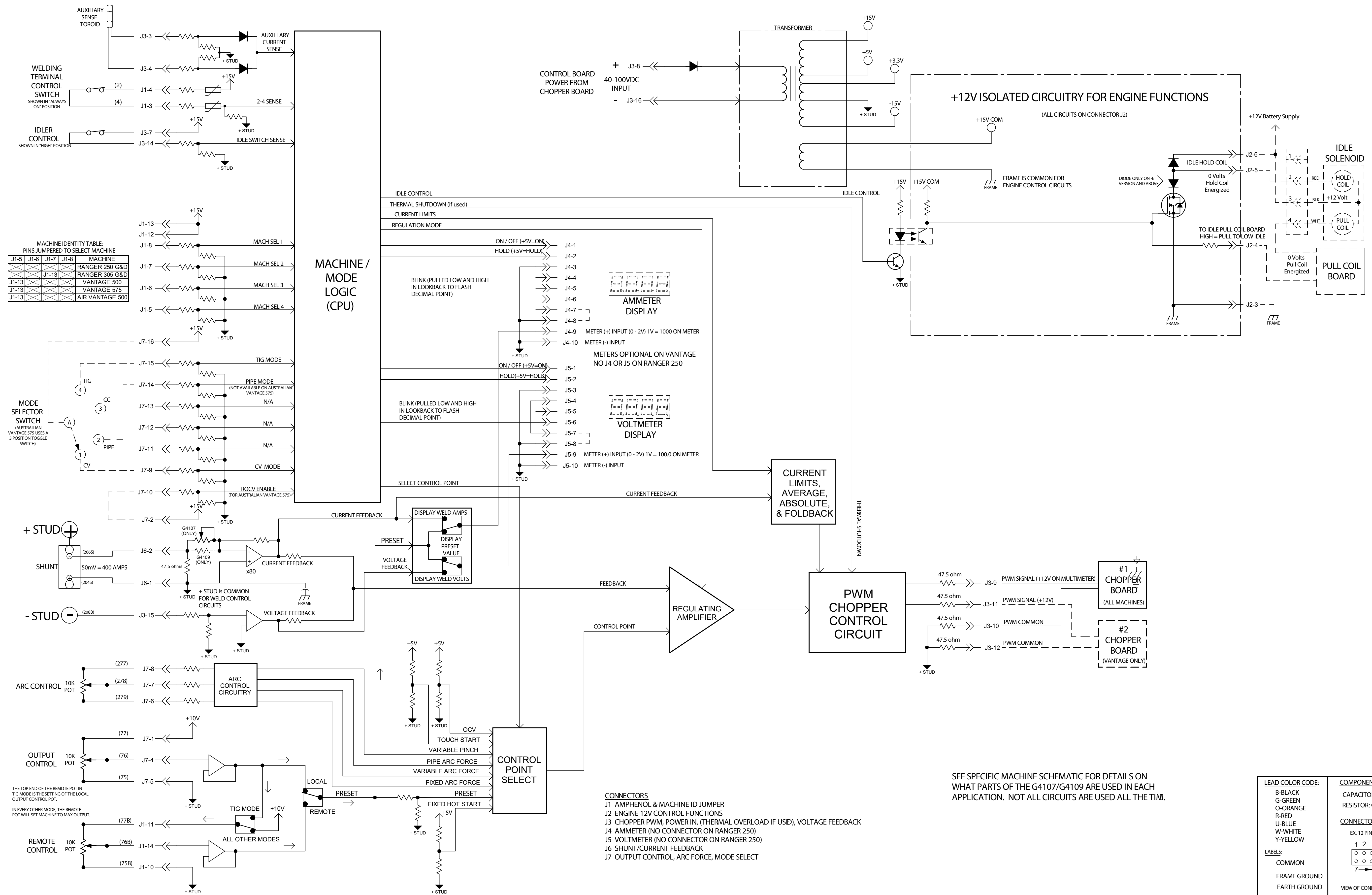

SEE SPECIFIC MACHINE SCHEMATIC FOR DETAILS ON WHAT PARTS OF THE G4107/G4109 ARE USED IN EACH APPLICATION. NOT ALL CIRCUITS ARE USED ALL THE TIME.