

POWER MIG 255 (208/230V) WIRING DIAGRAM REV: A

CAVITY NUMBERING SEQUENCE (COMPONENT SIDE OF P.C. BOARD)

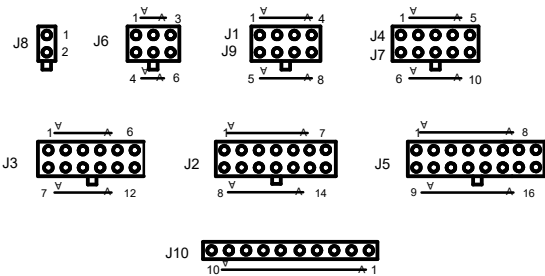

GENERAL INFORMATION

COLOR CODE:

B - BLACK
W - WHITE
R - RED
U - BLUE

INDICATES CONNECTOR CAVITY NO.

** CAVITY NUMBERING SEQUENCE (NON-LEAD SIDE OF CONNECTOR)

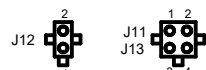

NOTES:

N.A. WELDING CABLE MUST BE OF PROPER CAPACITY FOR THE CURRENT AND DUTY CYCLE OF IMMEDIATE AND FUTURE APPLICATIONS.

N.B. THIS DIAGRAM SHOWS THE "ELECTRODE" POLARITY "POSITIVE". TO CHANGE POLARITY, TURN THE UNIT OFF AND REVERSE LEAD CONNECTIONS AT CABLE CONDUCTOR STRAP AND WORK STUD.

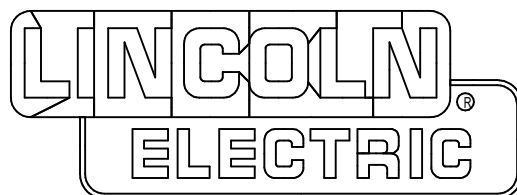
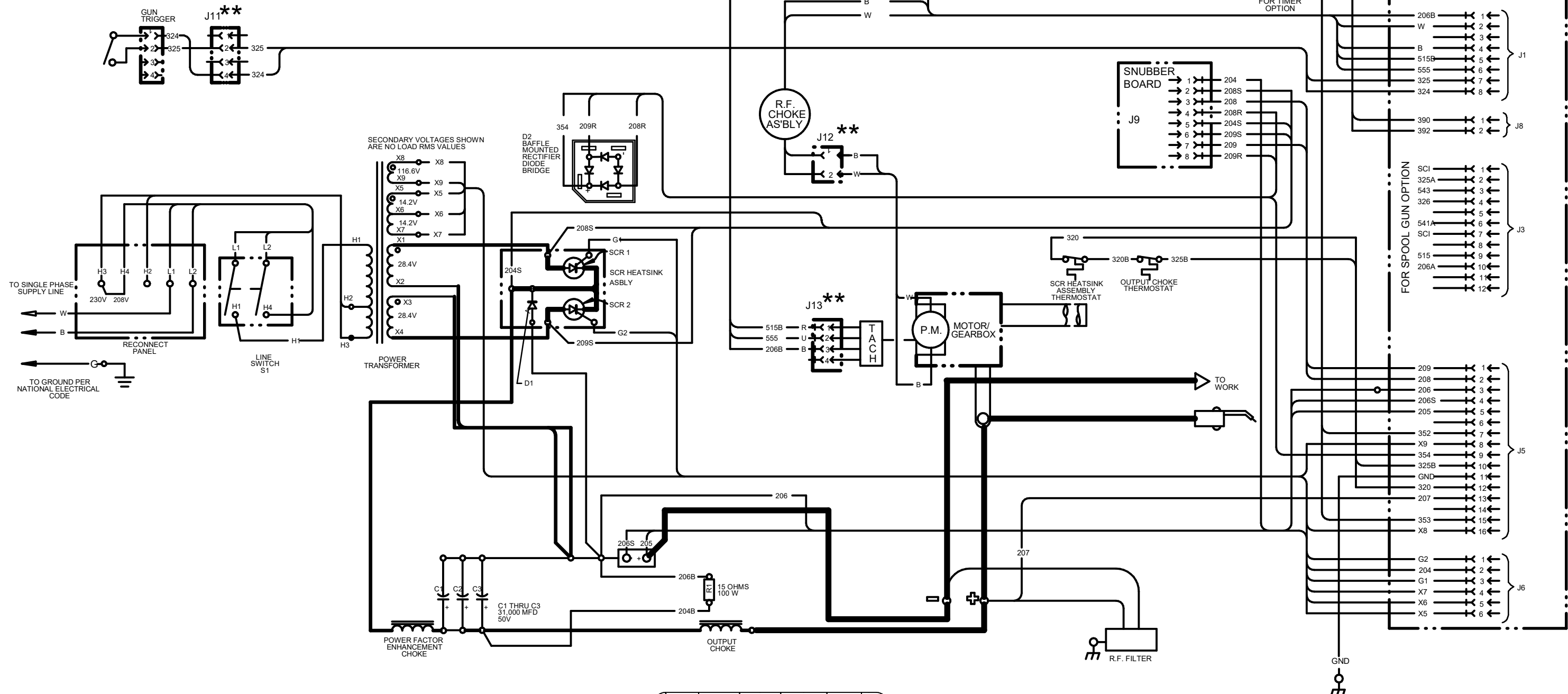
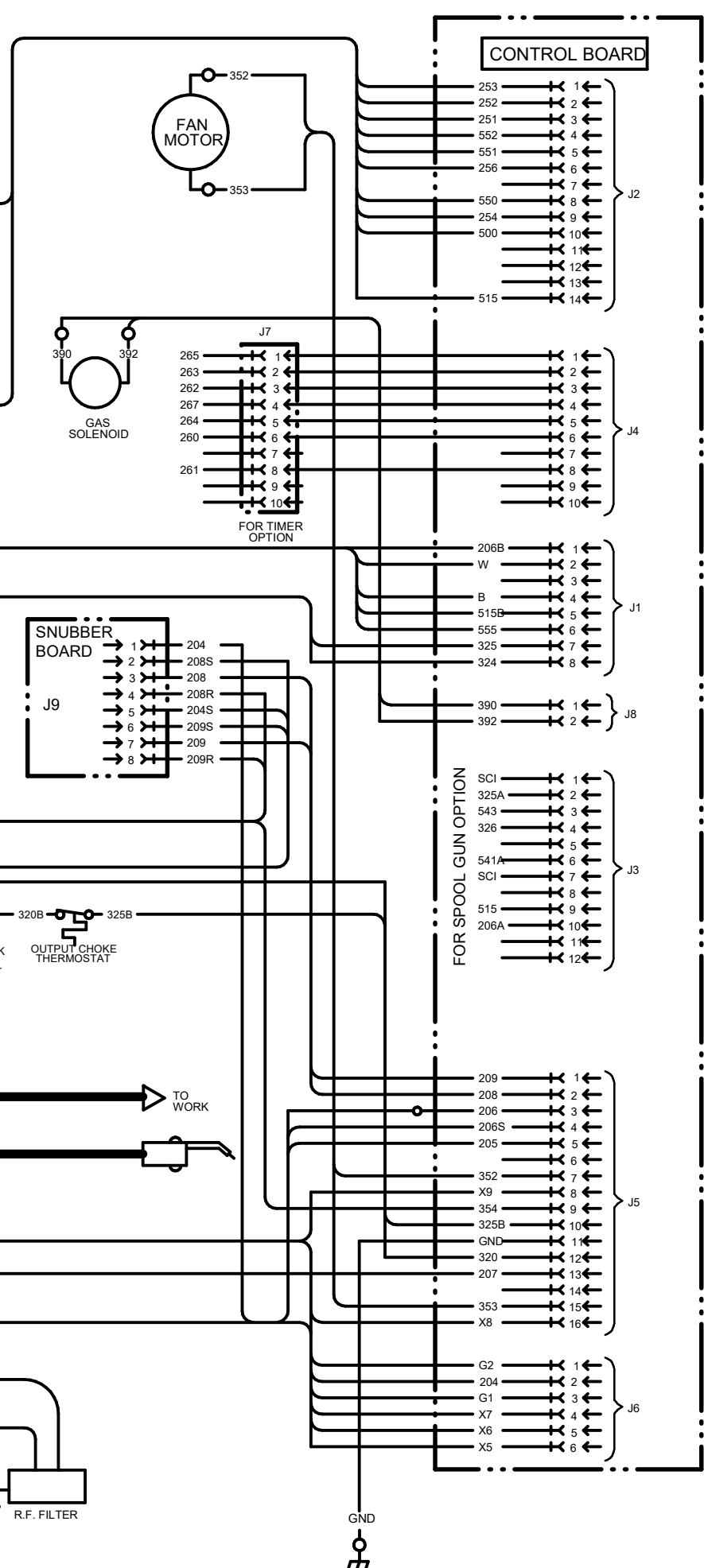
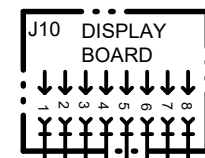

CLEVELAND, OHIO U.S.A.