



**NOTE:** This manual will cover most of the troubleshooting and repair procedures for the code numbers listed. Some variances may exist when troubleshooting/repairing later code numbers.

## ***PRECISION TIG 275***

For use with machines having Code Numbers:

**10806, 10807, 10893, 11158, 11159**

# ***SERVICE MANUAL***

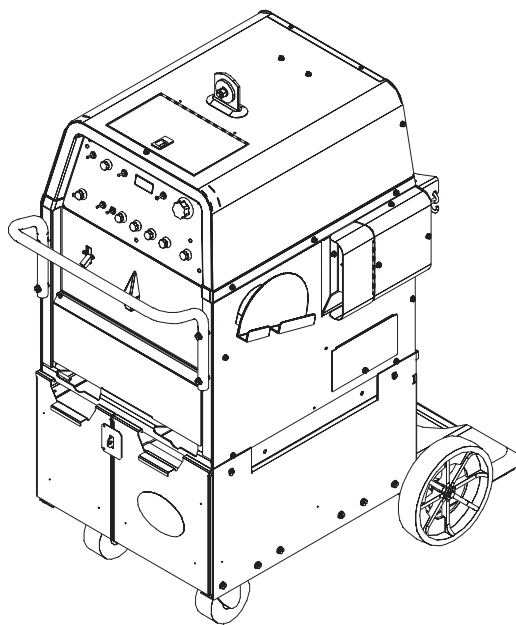

## ⚠️ WARNING

### ⚠️ CALIFORNIA PROPOSITION 65 WARNINGS ⚠️

Diesel engine exhaust and some of its constituents are known to the State of California to cause cancer, birth defects, and other reproductive harm.

The Above For Diesel Engines

The engine exhaust from this product contains chemicals known to the State of California to cause cancer, birth defects, or other reproductive harm.

The Above For Gasoline Engines

**ARC WELDING can be hazardous. PROTECT YOURSELF AND OTHERS FROM POSSIBLE SERIOUS INJURY OR DEATH. KEEP CHILDREN AWAY. PACEMAKER WEARERS SHOULD CONSULT WITH THEIR DOCTOR BEFORE OPERATING.**

Read and understand the following safety highlights. For additional safety information, it is strongly recommended that you purchase a copy of "Safety in Welding & Cutting - ANSI Standard Z49.1" from the American Welding Society, P.O. Box 351040, Miami, Florida 33135 or CSA Standard W117.2-1974. A Free copy of "Arc Welding Safety" booklet E205 is available from the Lincoln Electric Company, 22801 St. Clair Avenue, Cleveland, Ohio 44117-1199.

**BE SURE THAT ALL INSTALLATION, OPERATION, MAINTENANCE AND REPAIR PROCEDURES ARE PERFORMED ONLY BY QUALIFIED INDIVIDUALS.**



### FOR ENGINE powered equipment.

1.a. Turn the engine off before troubleshooting and maintenance work unless the maintenance work requires it to be running.



1.b. Operate engines in open, well-ventilated areas or vent the engine exhaust fumes outdoors.



1.c. Do not add the fuel near an open flame welding arc or when the engine is running. Stop the engine and allow it to cool before refueling to prevent spilled fuel from vaporizing on contact with hot engine parts and igniting. Do not spill fuel when filling tank. If fuel is spilled, wipe it up and do not start engine until fumes have been eliminated.

1.d. Keep all equipment safety guards, covers and devices in position and in good repair. Keep hands, hair, clothing and tools away from V-belts, gears, fans and all other moving parts when starting, operating or repairing equipment.

1.e. In some cases it may be necessary to remove safety guards to perform required maintenance. Remove guards only when necessary and replace them when the maintenance requiring their removal is complete. Always use the greatest care when working near moving parts.



1.f. Do not put your hands near the engine fan. Do not attempt to override the governor or idler by pushing on the throttle control rods while the engine is running.

1.g. To prevent accidentally starting gasoline engines while turning the engine or welding generator during maintenance work, disconnect the spark plug wires, distributor cap or magneto wire as appropriate.



1.h. To avoid scalding, do not remove the radiator pressure cap when the engine is hot.



### ELECTRIC AND MAGNETIC FIELDS may be dangerous

2.a. Electric current flowing through any conductor causes localized Electric and Magnetic Fields (EMF). Welding current creates EMF fields around welding cables and welding machines

2.b. EMF fields may interfere with some pacemakers, and welders having a pacemaker should consult their physician before welding.

2.c. Exposure to EMF fields in welding may have other health effects which are now not known.

2.d. All welders should use the following procedures in order to minimize exposure to EMF fields from the welding circuit:

2.d.1. Route the electrode and work cables together - Secure them with tape when possible.

2.d.2. Never coil the electrode lead around your body.

2.d.3. Do not place your body between the electrode and work cables. If the electrode cable is on your right side, the work cable should also be on your right side.

2.d.4. Connect the work cable to the workpiece as close as possible to the area being welded.

2.d.5. Do not work next to welding power source.

Mar '95



### ELECTRIC SHOCK can kill.

3.a. The electrode and work (or ground) circuits are electrically “hot” when the welder is on. Do not touch these “hot” parts with your bare skin or wet clothing. Wear dry, hole-free gloves to insulate hands.

3.b. Insulate yourself from work and ground using dry insulation. Make certain the insulation is large enough to cover your full area of physical contact with work and ground.

**In addition to the normal safety precautions, if welding must be performed under electrically hazardous conditions (in damp locations or while wearing wet clothing; on metal structures such as floors, gratings or scaffolds; when in cramped positions such as sitting, kneeling or lying, if there is a high risk of unavoidable or accidental contact with the workpiece or ground) use the following equipment:**

- Semiautomatic DC Constant Voltage (Wire) Welder.
- DC Manual (Stick) Welder.
- AC Welder with Reduced Voltage Control.

3.c. In semiautomatic or automatic wire welding, the electrode, electrode reel, welding head, nozzle or semiautomatic welding gun are also electrically “hot”.

3.d. Always be sure the work cable makes a good electrical connection with the metal being welded. The connection should be as close as possible to the area being welded.

3.e. Ground the work or metal to be welded to a good electrical (earth) ground.

3.f. Maintain the electrode holder, work clamp, welding cable and welding machine in good, safe operating condition. Replace damaged insulation.

3.g. Never dip the electrode in water for cooling.

3.h. Never simultaneously touch electrically “hot” parts of electrode holders connected to two welders because voltage between the two can be the total of the open circuit voltage of both welders.

3.i. When working above floor level, use a safety belt to protect yourself from a fall should you get a shock.

3.j. Also see Items 6.c. and 8.



### ARC RAYS can burn.

4.a. Use a shield with the proper filter and cover plates to protect your eyes from sparks and the rays of the arc when welding or observing open arc welding. Headshield and filter lens should conform to ANSI Z87.1 standards.

4.b. Use suitable clothing made from durable flame-resistant material to protect your skin and that of your helpers from the arc rays.

4.c. Protect other nearby personnel with suitable, non-flammable screening and/or warn them not to watch the arc nor expose themselves to the arc rays or to hot spatter or metal.



### FUMES AND GASES can be dangerous.

5.a. Welding may produce fumes and gases hazardous to health. Avoid breathing these fumes and gases. When welding, keep your head out of the fume. Use enough ventilation and/or exhaust at the arc to keep

fumes and gases away from the breathing zone. **When welding with electrodes which require special ventilation such as stainless or hard facing (see instructions on container or MSDS) or on lead or cadmium plated steel and other metals or coatings which produce highly toxic fumes, keep exposure as low as possible and below Threshold Limit Values (TLV) using local exhaust or mechanical ventilation. In confined spaces or in some circumstances, outdoors, a respirator may be required. Additional precautions are also required when welding on galvanized steel.**

5. b. The operation of welding fume control equipment is affected by various factors including proper use and positioning of the equipment, maintenance of the equipment and the specific welding procedure and application involved. Worker exposure level should be checked upon installation and periodically thereafter to be certain it is within applicable OSHA PEL and ACGIH TLV limits.

5.c. Do not weld in locations near chlorinated hydrocarbon vapors coming from degreasing, cleaning or spraying operations. The heat and rays of the arc can react with solvent vapors to form phosgene, a highly toxic gas, and other irritating products.

5.d. Shielding gases used for arc welding can displace air and cause injury or death. Always use enough ventilation, especially in confined areas, to insure breathing air is safe.

5.e. Read and understand the manufacturer’s instructions for this equipment and the consumables to be used, including the material safety data sheet (MSDS) and follow your employer’s safety practices. MSDS forms are available from your welding distributor or from the manufacturer.

5.f. Also see item 1.b.

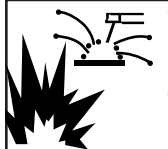

### WELDING SPARKS can cause fire or explosion.

6.a. Remove fire hazards from the welding area.

If this is not possible, cover them to prevent the welding sparks from starting a fire.

Remember that welding sparks and hot materials from welding can easily go through small cracks and openings to adjacent areas. Avoid welding near hydraulic lines. Have a fire extinguisher readily available.

6.b. Where compressed gases are to be used at the job site, special precautions should be used to prevent hazardous situations. Refer to "Safety in Welding and Cutting" (ANSI Standard Z49.1) and the operating information for the equipment being used.

6.c. When not welding, make certain no part of the electrode circuit is touching the work or ground. Accidental contact can cause overheating and create a fire hazard.

6.d. Do not heat, cut or weld tanks, drums or containers until the proper steps have been taken to insure that such procedures will not cause flammable or toxic vapors from substances inside. They can cause an explosion even though they have been "cleaned". For information, purchase "Recommended Safe Practices for the Preparation for Welding and Cutting of Containers and Piping That Have Held Hazardous Substances", AWS F4.1 from the American Welding Society (see address above).

6.e. Vent hollow castings or containers before heating, cutting or welding. They may explode.

6.f. Sparks and spatter are thrown from the welding arc. Wear oil free protective garments such as leather gloves, heavy shirt, cuffless trousers, high shoes and a cap over your hair. Wear ear plugs when welding out of position or in confined places. Always wear safety glasses with side shields when in a welding area.

6.g. Connect the work cable to the work as close to the welding area as practical. Work cables connected to the building framework or other locations away from the welding area increase the possibility of the welding current passing through lifting chains, crane cables or other alternate circuits. This can create fire hazards or overheat lifting chains or cables until they fail.

6.h. Also see item 1.c.



### CYLINDER may explode if damaged.

7.a. Use only compressed gas cylinders containing the correct shielding gas for the process used and properly operating regulators designed for the gas and pressure used. All hoses, fittings, etc. should be suitable for the application and maintained in good condition.

7.b. Always keep cylinders in an upright position securely chained to an undercarriage or fixed support.

7.c. Cylinders should be located:

- Away from areas where they may be struck or subjected to physical damage.

- A safe distance from arc welding or cutting operations and any other source of heat, sparks, or flame.

7.d. Never allow the electrode, electrode holder or any other electrically "hot" parts to touch a cylinder.

7.e. Keep your head and face away from the cylinder valve outlet when opening the cylinder valve.

7.f. Valve protection caps should always be in place and hand tight except when the cylinder is in use or connected for use.

7.g. Read and follow the instructions on compressed gas cylinders, associated equipment, and CGA publication P-1, "Precautions for Safe Handling of Compressed Gases in Cylinders," available from the Compressed Gas Association 1235 Jefferson Davis Highway, Arlington, VA 22202.



### FOR ELECTRICALLY powered equipment.

8.a. Turn off input power using the disconnect switch at the fuse box before working on the equipment.

8.b. Install equipment in accordance with the U.S. National Electrical Code, all local codes and the manufacturer's recommendations.

8.c. Ground the equipment in accordance with the U.S. National Electrical Code and the manufacturer's recommendations.

## PRÉCAUTIONS DE SÛRETÉ

Pour votre propre protection lire et observer toutes les instructions et les précautions de sûreté spécifiques qui paraissent dans ce manuel aussi bien que les précautions de sûreté générales suivantes:

### Sûreté Pour Soudage A L'Arc

1. Protégez-vous contre la secousse électrique:
  - a. Les circuits à l'électrode et à la pièce sont sous tension quand la machine à souder est en marche. Eviter toujours tout contact entre les parties sous tension et la peau nue ou les vêtements mouillés. Porter des gants secs et sans trous pour isoler les mains.
  - b. Faire très attention de bien s'isoler de la masse quand on soude dans des endroits humides, ou sur un plancher métallique ou des grilles métalliques, principalement dans les positions assis ou couché pour lesquelles une grande partie du corps peut être en contact avec la masse.
  - c. Maintenir le porte-électrode, la pince de masse, le câble de soudage et la machine à souder en bon et sûr état de fonctionnement.
  - d. Ne jamais plonger le porte-électrode dans l'eau pour le refroidir.
  - e. Ne jamais toucher simultanément les parties sous tension des porte-électrodes connectés à deux machines à souder parce que la tension entre les deux pinces peut être le total de la tension à vide des deux machines.
  - f. Si on utilise la machine à souder comme une source de courant pour soudage semi-automatique, ces précautions pour le porte-électrode s'appliquent aussi au pistolet de soudage.
2. Dans le cas de travail au dessus du niveau du sol, se protéger contre les chutes dans le cas où on reçoit un choc. Ne jamais enrouler le câble-électrode autour de n'importe quelle partie du corps.
3. Un coup d'arc peut être plus sévère qu'un coup de soliel, donc:
  - a. Utiliser un bon masque avec un verre filtrant approprié ainsi qu'un verre blanc afin de se protéger les yeux du rayonnement de l'arc et des projections quand on soude ou quand on regarde l'arc.
  - b. Porter des vêtements convenables afin de protéger la peau de soudeur et des aides contre le rayonnement de l'arc.
  - c. Protéger l'autre personnel travaillant à proximité au soudage à l'aide d'écrans appropriés et non-inflammables.
4. Des gouttes de laitier en fusion sont émises de l'arc de soudage. Se protéger avec des vêtements de protection libres de l'huile, tels que les gants en cuir, chemise épaisse, pantalons sans revers, et chaussures montantes.
5. Toujours porter des lunettes de sécurité dans la zone de soudage. Utiliser des lunettes avec écrans latéraux dans les zones où l'on pique le laitier.

6. Eloigner les matériaux inflammables ou les recouvrir afin de prévenir tout risque d'incendie dû aux étincelles.
7. Quand on ne soude pas, poser la pince à un endroit isolé de la masse. Un court-circuit accidentel peut provoquer un échauffement et un risque d'incendie.
8. S'assurer que la masse est connectée le plus près possible de la zone de travail qu'il est pratique de le faire. Si on place la masse sur la charpente de la construction ou d'autres endroits éloignés de la zone de travail, on augmente le risque de voir passer le courant de soudage par les chaînes de levage, câbles de grue, ou autres circuits. Cela peut provoquer des risques d'incendie ou d'échauffement des chaînes et des câbles jusqu'à ce qu'ils se rompent.
9. Assurer une ventilation suffisante dans la zone de soudage. Ceci est particulièrement important pour le soudage de tôles galvanisées plombées, ou cadmiées ou tout autre métal qui produit des fumées toxiques.
10. Ne pas souder en présence de vapeurs de chlore provenant d'opérations de dégraissage, nettoyage ou pistolage. La chaleur ou les rayons de l'arc peuvent réagir avec les vapeurs du solvant pour produire du phosgène (gas fortement toxique) ou autres produits irritants.
11. Pour obtenir de plus amples renseignements sur la sûreté, voir le code "Code for safety in welding and cutting" CSA Standard W 117.2-1974.

## PRÉCAUTIONS DE SÛRETÉ POUR LES MACHINES À SOUDER À TRANSFORMATEUR ET À REDRESSEUR

1. Relier à la terre le châssis du poste conformément au code de l'électricité et aux recommandations du fabricant. Le dispositif de montage ou la pièce à souder doit être branché à une bonne mise à la terre.
2. Autant que possible, l'installation et l'entretien du poste seront effectués par un électricien qualifié.
3. Avant de faire des travaux à l'intérieur de poste, la débrancher à l'interrupteur à la boîte de fusibles.
4. Garder tous les couvercles et dispositifs de sûreté à leur place.

	Page
<b>Safety</b> .....	i-iv
<b>Installation</b> .....	<b>Section A</b>
<b>Operation</b> .....	<b>Section B</b>
<b>Accessories</b> .....	<b>Section C</b>
<b>Maintenance</b> .....	<b>Section D</b>
<b>Theory of Operation</b> .....	<b>Section E</b>
<b>Troubleshooting and Repair</b> .....	<b>Section F</b>
How to Use Troubleshooting Guide .....	F-2
Safety Precautions .....	F-3
Troubleshooting Guide .....	F-4
Test Procedures .....	F-19
Oscilloscope Waveforms .....	F-39
Replacement Procedures .....	F-45
Retest After Repair .....	F-61
<b>Electrical Diagrams</b> .....	<b>Section G</b>
<b>Parts Manual</b> .....	<b>P404 &amp; P558 Series</b>

# TABLE OF CONTENTS - INSTALLATION SECTION -

## Installation

Technical Specifications.....	A-2
Rated Output.....	A-3
Additional Output Capacity .....	A-3
Wire and Fuse Sizes.....	A-3
Physical Dimensions.....	A-3
Temperature Ranges .....	A-3
Safety Precautions.....	A-4
Stacking .....	A-4
Lifting and Moving.....	A-4
Tilting.....	A-4
High Frequency Interference Protection .....	A-4
Input Electrical Connections .....	A-5
Ground Connection.....	A-5
Output Cables, Connections & Limitations .....	A-6
TIG Torch Connection .....	A-7
Auxiliary Power Connections .....	A-8
Remote Control.....	A-8
Robotic Interface Connection .....	A-9

Return to Master TOC

Return to Master TOC

Return to Master TOC



Return to Master TOC

PRECISION TIG 275





TECHNICAL SPECIFICATIONS-PRECISION TIG 275 (Domestic, Canadian & Export

RATED INPUT - SINGLE PHASE ONLY				
K Number	Duty Cycle-Applications	Voltage ± 10%	Max. Amps With Out Power Factor Capacitor	Max. Amps With Power Factor Capacitor
 NRTL/C	40% AC/DC Stick / Balance TIG Unbalance (70% Penetration#) AC TIG	208/230/460	104/94/47 124/112/56	80/72/36 95/86/43
	60% AC/DC Stick / Balance TIG Unbalance (70% Penetration#) AC TIG		86/78/39 95/86/43	64/58/29 62/56/28
	100% AC/DC Stick / Balance TIG Unbalance (70% Penetration#) AC TIG		77/70/35 73/66/33	55/50/25 40/36/18
	Idle Amps		6/5/3	36/32/16
	Idle Power			
 NRTL/C	40% AC/DC Stick / Balance TIG Unbalance (70% Penetration#) AC TIG	460/575	47/38 56/45	35/28 43/34
	60% AC/DC Stick / Balance TIG Unbalance (70% Penetration#) AC TIG		39/31 43/35	29/23 28/23
	100% AC/DC Stick / Balance TIG Unbalance (70% Penetration#) AC TIG		35/28 33/26	25/20 18/14
	Idle Amps		3/2	16/13
	Idle Power		300W	500W
 IEC 60974-1	40% AC/DC Stick / Balance TIG Unbalance (70% Penetration#) AC TIG	220-230/ 380-400/415	95/55/50 109/63/58	80/46/43 86/50/46
	60% AC/DC Stick / Balance TIG Unbalance (70% Penetration#) AC TIG		80/46/42 85/49/45	64/37/34 67/39/36
	100% AC/DC Stick / Balance TIG Unbalance (70% Penetration#) AC TIG		70/41/37 65/38/35	52/30/28 46/27/25
	Idle Amps		10/6/5	23/13/12
	Idle Power		400W	500W
RATED POWER FACTOR (STICK)		K1825-1,K1826-1 & K1826-2 K1827-1	.63 min. .65 min.	.85 min. .77 min.
RATED OUTPUT - NEMA EW1 Class II (40) K1825-1,K1826-1,-2, K2619-1.-2				
Duty Cycle-Applications		Volts at Rated Amperes		Amps
40% AC/DC Stick / Balance TIG Unbalance (70% Penetration#) AC TIG		31.0 16.1		275 255
60% AC/DC Stick / Balance TIG Unbalance (70% Penetration#) AC TIG		29.0 15.4		225 200
100% AC/DC Stick / Balance TIG Unbalance (70% Penetration#) AC TIG		28.0 14.8		200 150

\*Shown on Front of this IM manual with Under-Cooler Cart and Advanced Control Panel (Refer to Optional Equipment)

#Exceeds NEMA Unbalanced Load Specification comparable for Auto-Balance.

PRECISION TIG 275



Return to Section TOC

Return to Master TOC



### RATED OUTPUT - IEC 60974-1 (K1827-1)

Duty Cycle-Applications	Volts at Rated Amperes	Amps
40%		
AC/DC Stick / Balance TIG	31.0	275
Unbalance (70% Penetration#) AC TIG	20.2	255
60%		
AC/DC Stick / Balance TIG	29.0	225
Unbalance (70% Penetration#) AC TIG	18.0	200
100%		
AC/DC Stick / Balance TIG	28.0	200
Unbalance (70% Penetration#) AC TIG	16.0	150

### ADDITIONAL OUTPUT CAPACITY

Output Current Range	Maximum Open Circuit Voltage	Type of Output	Auxiliary Power
2Amps DC to 340Amps AC-DC*	(STICK AND TIG) AC/DC OCV: 75/68	CC (Constant Current) AC/DC (GTAW) Stick (SMAW)	K1825-1, K1826-1, K1826-2 15Amp Circuit Breaker and NEMA 5-15R Duplex Receptacle for up to: 115VAC 8Amp Auxiliary Power Receptacle 115VAC weld Switched Cooler Receptacle load K1834-1 5 Amp Circuit Breaker and grounded 220VAC Euro(Schuko) receptacle

### RECOMMENDED INPUT WIRE AND FUSE SIZES

For all Stick, DC TIG, and Balanced AC TIG Welding at 275A/40% Duty Cycle with out Standard Power Factor Correction Capacitors Based on the 1999 U.S. National Electrical Code					For Unbalanced AC TIG Welding Above 275 Amps: 255A/40% Duty Cycle, Auto-Balance Penetration with out Standard Power Factor Correction Capacitors Based on the 1999 U.S. National Electrical Code			
Input Voltage / phase/ Frequency	Fuse (Super Lag) or Breaker Size <sup>1</sup>	Input Ampere Rating Rating on Nameplate	Type 75°C Copper Wire in Conduit AWG (IEC) Sizes 40°C (104°F) Ambient	Type 75°C Copper Ground Wire in Conduit AWG (IEC) Sizes	Fuse (Super Lag) or Breaker Size <sup>1</sup>	Input Ampere Rating	Type 75°C Copper Wire in Conduit AWG (IEC) Sizes 40°C (104°F) Ambient	Type 75°C Copper Ground Wire in Conduit AWG (IEC) Sizes
208/1/60	125	104	4 (21.2 mm <sup>2</sup> )	6 (13.3 mm <sup>2</sup> )	150	124	3 (26.7 mm <sup>2</sup> )	6 (13.3 mm <sup>2</sup> )
230/1/60	125	94	4 (21.2 mm <sup>2</sup> )	6 (13.3 mm <sup>2</sup> )	150	112	3 (26.7 mm <sup>2</sup> )	6 (13.3 mm <sup>2</sup> )
460/1/60	60	47	8 (8.4mm <sup>2</sup> )	10 (5.3mm <sup>2</sup> )	70	56	8 (8.4 mm <sup>2</sup> )	8 (8.4 mm <sup>2</sup> )
575/1/60	50	38	10 (5.3mm <sup>2</sup> )	10 (5.3mm <sup>2</sup> )	60	45	8 (8.4 mm <sup>2</sup> )	10 (5.3mm <sup>2</sup> )
220-230/1/50/60	125	95	4 (21.2 mm <sup>2</sup> )	6 (13.3 mm <sup>2</sup> )	150	109	4 (21.2 mm <sup>2</sup> )	6 (13.3 mm <sup>2</sup> )
380-400/1/50/60	80	55	8 (8.4mm <sup>2</sup> )	8 (8.4mm <sup>2</sup> )	90	63	6 (13.3 mm <sup>2</sup> )	8 (8.4 mm <sup>2</sup> )
415/1/50/60	80	50	8 (8.4mm <sup>2</sup> )	8 (8.4mm <sup>2</sup> )	90	58	6 (13.3 mm <sup>2</sup> )	8 (8.4 mm <sup>2</sup> )

### PHYSICAL DIMENSIONS

	Height	Width	Depth	Weight
K1826-1, -2 K1827-1 K2619-1,-2	31.0 in. 787 mm	22.0 in. 559 mm	26.0 in. 660 mm	Approx. 397 lbs. 180 kgs.
K1825-1	49.7 in. 1262 mm	28.0 in. 711 mm	41.0 in. 1041 mm	Approx. 641 lbs. 291 kgs.

### TEMPERATURE RANGES

OPERATING TEMPERATURE RANGE -20°C to +40°C (-04° to +104°F)	STORAGE TEMPERATURE RANGE -40°C to +85°C (-40° to +185°F)
TRANSFORMER INSULATION CLASS 180°C (H)	

<sup>1</sup> ALSO CALLED "INVERSE TIME" OR "THERMAL/MAGNETIC " CIRCUIT BREAKERS; CIRCUIT BREAKERS WHICH HAVE A DELAY IN TRIPPING ACTION THAT DECREASES AS THE MAGNITUDE OF CURRENT INCREASES.

\* 50/60Hz IEC Max. range exceeds 310A.

PRECISION TIG 275



## SAFETY PRECAUTIONS

Read entire Installation Section before installing the Precision Tig 275.

### ⚠ WARNING



#### ELECTRIC SHOCK can kill.

- Only qualified personnel should perform this installation.
- Turn the input power OFF at the disconnect switch or fuse box and discharge input capacitors before working inside the equipment.
- Do not touch electrically hot parts.
- Always connect the Precision Tig grounding screw (behind the reconnect panel cover located near the back of the left case side) to a good electrical earth ground.
- Always connect the Precision Tig to a power supply grounded in accordance with the National Electrical Code and all local codes.

## SELECT SUITABLE LOCATION

Place the welder where clean cool air can freely circulate in through the rear louvers and out through the bottom opening. Dirt, dust or any foreign material that can be drawn into the machine should be kept at a minimum. Failure to observe these precautions can result in excessive operating temperatures and nuisance trips.

### GRINDING

Do not direct grinding particles towards the welder. An abundance of conductive material can cause maintenance problems.

### STACKING

The Precision Tig 275 cannot be stacked.

## UNDERCARRIAGE LIFTING AND MOVING

When the Precision TIG 275 is purchased as a welding package, or used with any of the available Undercarriage optional accessories, proper installation makes the Precision TIG 275 lift bale nonfunctional. Do not attempt to lift the power source with an undercarriage attached. The undercarriage is designed for hand moving only; mechanized movement can lead to personal injury and/or damage to the Precision TIG 275.

### TILTING

Each machine must be placed on a secure, level surface, either directly or on a recommended undercarriage.

The machine may topple over if this precaution is not followed.

## ENVIRONMENTAL RATING

Precision TIG 275 power sources carry an IP21S Environmental rating. They are rated for use in damp, dirty rain-sheltered environments.

## HIGH FREQUENCY INTERFERENCE PROTECTION

The frame of the welder must be grounded. A ground screw marked with the symbol (⊥) is located on the input connection panel (Figure A.1) for this purpose. See your local and national electrical codes for proper grounding methods.

The spark gap oscillator in the high frequency generator, being similar to a radio transmitter, can be blamed for many radio, TV and electronic equipment interference problems. These problems may be the result of radiated interference. Proper grounding methods can be reduced or eliminate re-radiated interference.

The Precision TIG 275 has been field tested under recommended installation conditions and has been found to comply with F.C.C. allowable radiation limits. This welder has also been found to comply with NEMA standards for high frequency stabilized power sources.

Radiated interference can develop in the following four ways:

- \* Direct interference radiated from the welder.
- \* Direct interference radiated from the welding leads.
- \* Direct interference radiated from the feedback into the power lines.
- \* Interference from re-radiation of "pickup" by ungrounded metallic objects.

Keeping these contributing factors in mind, installing the equipment per the following instructions should minimize problems.

1. Keep the welder power supply lines as short as possible and completely enclose them in rigid metallic conduit or equivalent shielding for a minimum distance of 50 feet (15.2 m). There must be good electrical contact between this conduit must be connected to a driven ground and the entire length must be continuous.
2. Keep the work and electrode leads as short as possible and as close together as possible. Lengths should not exceed 25 feet (7.6m). Tape the leads together when practical.

## PRECISION TIG 275



3. Be sure the torch and work cable rubber coverings are free of cuts and cracks that allow high frequency leakage. Cables with high natural rubber content, such as Lincoln Stable-Arc<sup>®</sup> better resist high frequency leakage than neoprene and other synthetic rubber insulated cables.
4. Keep the torch in good repair and all connections tight to reduce high frequency leakage.
5. The work terminal must be connected to a ground\* within ten feet of the welder, using one of the following methods.

\* A metal underground water pipe in direct contact with the earth for ten feet or more.

\* A 3/4" (19mm) galvanized pipe or a 5/8" (16mm) solid galvanized iron, steel or copper rod driven at least eight feet into the ground.

The ground should be securely made and the grounding cable should be as short as possible using cable of the same size as the work cable, or larger. Grounding to the building frame electrical conduit or a long pipe system can result in re-radiation, effectively making these members radiating antennas. (This is not recommended.)

6. Keep all access panels and covers securely in place.
7. All electrical conductors within 50 feet (15.2m) of the welder should be enclosed in grounded rigid metallic conduit or equivalent shielding. Flexible helically-wrapped metallic conduit is generally not suitable.
8. When the welder is enclosed in a metal building, several earth driven electrical grounds (as in 5 above) around the periphery of the building are recommended.

Failure to observe these recommended installation procedures can cause radio or TV interference problems and result in unsatisfactory welding performance resulting from lost high frequency power.

## INPUT and GROUNDING CONNECTIONS

### ⚠ WARNING



**ELECTRIC SHOCK can kill.**

\* **Turn the input power OFF at the disconnect switch or fuse box before working on this equipment.**

Be sure the voltage, phase, and frequency of the input power is as specified on the rating plate, located on the rear of the machine.

Fuse the input circuit with the recommended super lag fuses or delay type 1 circuit breakers. Choose an input and grounding wire size according to local or national codes or use Section A-2. Using fuses or circuit breakers smaller than recommended may result in "nuisance" tripping from welder inrush currents even if not welding at high currents.

Unbalanced AC TIG welding draws higher input currents than those for Stick, DC TIG, or Balanced AC TIG welding. The welder is designed for these higher input currents. However, where unbalanced AC TIG welding above 185 amps is planned, the higher input currents require larger input wire sizes and fuses per Section A-2:

Remove the reconnect panel cover located near the back of the left case side to reveal the reconnected panel. Welder supply line entry provision is in the case rear panel. Entry is through a 1.75 inch (44mm) diameter hole in the case back. Appropriate supply line strain relief clamp is provided by installer. (See Figure A.1)

**All connections should be made in accordance**

**FIGURE A.1**

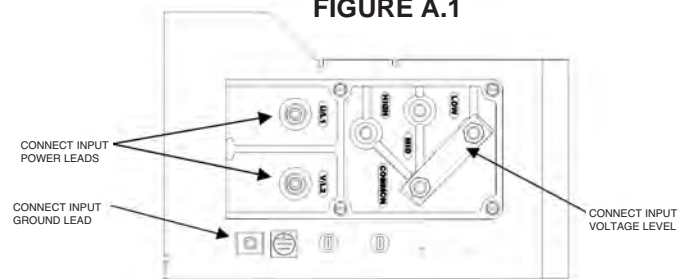

**with all local codes and national electrical codes. Installation by a qualified electrician is recommended.**

1. Connect the terminal marked  $\oplus$  (below the reconnect panel) to an earth ground.
2. Connect the input leads to terminals marked L1 (U) and L2 (V) on the reconnect panel. Use a single phase line or one phase of a two or three phase line.
3. On multiple input voltage welders, be sure the reconnect panel is connected for the voltage being supplied to the welder.

### CAUTION

Failure to follow these instructions can cause immediate failure of components within the welder.

Welders are shipped connected for the highest input voltage as listed on the rating plate. To change this connection, designations on the reconnect panel LOW, MID, and HIGH correspond to the name plated input voltages of a triple voltage welder. Dual voltage welders use only LOW and HIGH.

**EXAMPLE:** On a 208/230/460 volt welder, LOW is 208V, MID is 230V, and HIGH is 460V.

**NOTE:** Export model has a voltage range for LOW and MID connections: LOW is 220-230V, MID is 280-400V and high is 415V.

Reconnect the jumper strap to the terminal stud corresponding to the input voltage level used. Make sure all connections are tight.

### WARNING

#### OUTPUT CABLES, CONNECTIONS AND LIMITATIONS

- To avoid being startled by a high frequency shock, keep the TIG torch and cables in good condition
- Turn the power switch of the power source OFF before installing adapters on cable or when connecting or disconnecting adapter plugs to power source.

Refer to Figure A.2 for the location of the WORK and STICK terminals, as well as the TIG Torch connection panel.

Recommended Cable Sizes for Combined Lengths of Copper Work and Electrode Cables using 75° C Wire:

Machine Rating	0 to 100 Ft.	101 to 200 Ft	201 to 250 Ft
275A/40%	#1 (42.4 mm <sup>2</sup> )	1/0 (53.5 mm <sup>2</sup> )	2/0 (67.4 mm <sup>2</sup> )

### WORK CABLE CONNECTION

A 15' (2/0) weld cable with clamp is available (K2150-1), or included with the Precision TIG Welding Package model. Otherwise, it is user provided.

With power source off, connect a separate work cable to the 1/2-13 threaded "WORK" stud of the welder, and secure a tight connection with the flange nut provided. The work cable should be routed through the cable strain relief hole provided in the base directly below the welding output terminal.

**Note:** If the Precision TIG is equipped with an Under-Cooler or Under-Storage unit, the coiled work cable and clamp, or excess work cable length, may be conveniently stored in the drawer while remaining connected.

### STICK ELECTRODE CABLE CONNECTION

If manual stick welding is desired, with power source off, connect a stick electrode cable to the 1/2-13 threaded "STICK Electrode" stud of the welder, and secure a tight connection with the flange nut provided. The electrode cable should be routed through the cable strain relief hole provided in the base directly below the welding output terminal.

### WARNING

**DISCONNECT STICK ELECTRODE WELDING CABLE WHEN TIG WELDING.**

**EVEN THOUGH HI-FREQ IS NOT APPLIED TO THE PRECISION TIG STICK TERMINAL, IT WILL BE ELECTRICALLY "HOT" TO WORK WHEN TIG WELDING.**

PRECISION TIG 275



FIGURE A.2

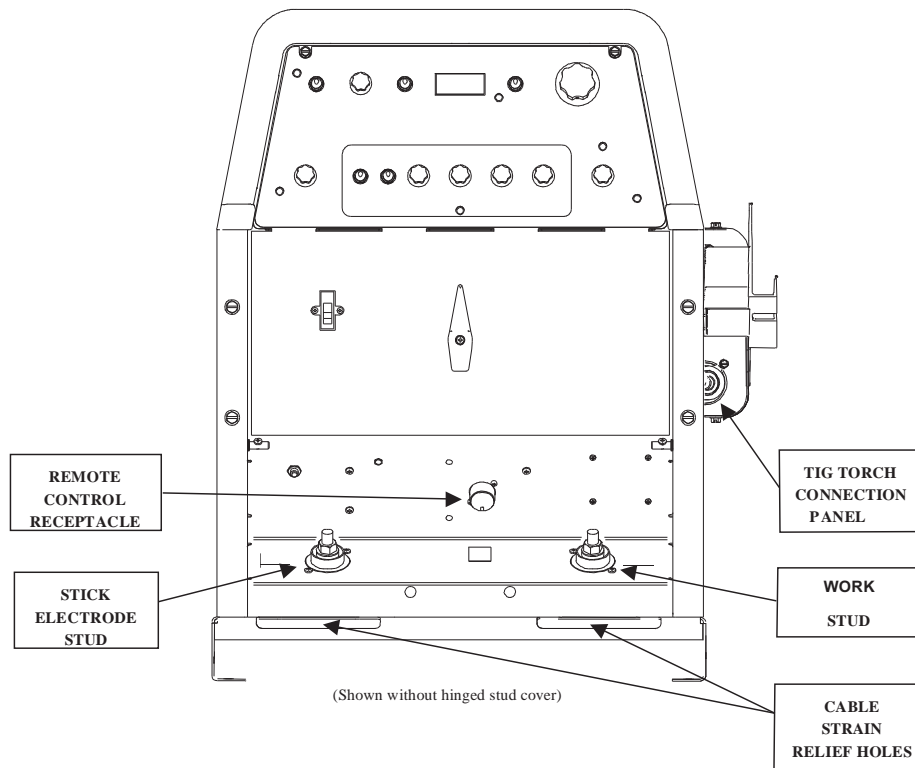

## TIG TORCH CONNECTION

The Precision TIG torch connection box, located on the right side of the machine, provides all the input and output connections for the installation of both air-cooled and water-cooled TIG torches with fittings conforming to Compressed Gas Association (CGA) standards:

**Note:** The Precision TIG provides an insulated Torch Reel and Holster for handy and safe storage of connected torch when not welding, and excess torch cable length while welding.

### ⚠ WARNING

**Combination connectors (Power/Water and Power/Gas) are electrically "hot" while welding in STICK or TIG modes.**

**If using an Air-Cooled Torch be sure coolant is shut off and/or Cooler is unplugged from the Precision TIG Water Cooler Receptacle on the torch side of the upper case back.**

**Observe the safety precautions necessary for handling and using compressed gas containers. Contact your supplier for specifics.**

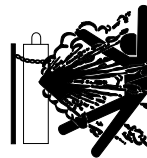

**CYLINDER could explode if damaged.**

- **Keep cylinder upright and chained to a support.**
- **Keep cylinder away from areas where it could be damaged.**
- **Never allow the torch to touch the cylinder.**
- **Keep cylinder away from live electrical circuits.**
- **Maximum inlet pressure 150 psi.**

The Precision TIG machines do not have Hi-Freq. available at the Stick electrode stud, therefore stud connection adapters (such as LECO. S19257-series) cannot be used for torch connection.

Single-piece cable air-cooled torches with a 3/8-24 RH connector fitting (such as the Magnum PTA-9/-17, or LA-9/-17) require the provided S20403-4 Torch Connector, while those with a 7/8-14 RH connector fitting (such as the Magnum PTA-26, or LA-26) require the available K2166-1 Torch Connector. (See **Figure A.3**)

Two-piece cable air-cooled torches (such as PTA-, or LA-torches) can be used with the available 1/2" Stud Connector (S20403-3) with with a 7/8-14 LH male fitting.

Magnum PTW-18/-20 (or LW-) water-cooled Torches require no adapter for Precision TIG connection.

PRECISION TIG 275





FIGURE A.3

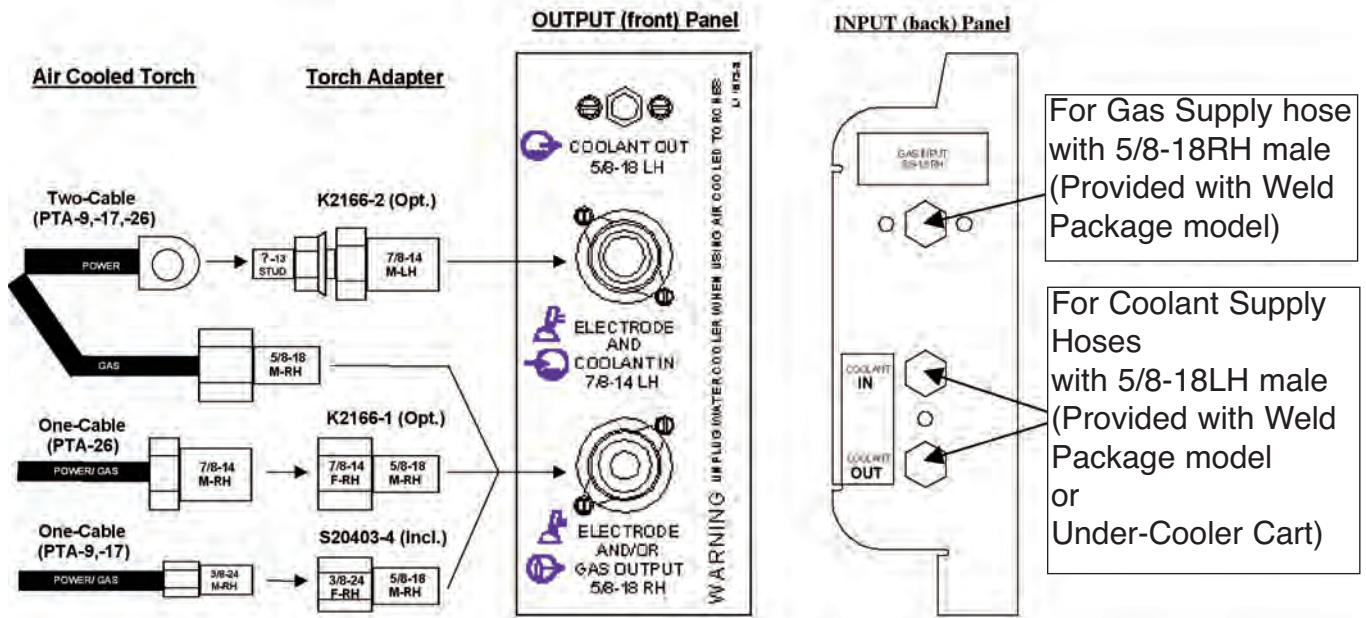

## AUXILIARY POWER CONNECTIONS

The Precision TIG machines provide a standard NEMA 5-15R duplex receptacle, located on the upper case back on the torch side of the machine:

- The bottom outlet of this duplex receptacle provides switched 115VAC power for the Under-Cooler, or Water Solenoid accessory. This Cooler receptacle turns on when the arc starts and remains on for about 8 minutes after the arc goes out (with the Fan-As-Needed machine cooling fan, see Maintenance Section), so the Cooler's fan and water pump will not run continuously in idle, but will run while welding.
- The top outlet of this duplex receptacle provides at least 8 amps at 115VAC, whenever the Precision TIG Power switch is ON. This auxiliary circuit is intended for running 115VAC accessories or small power tools. **Note:** Some types of equipment, especially pumps and large motors, have starting currents which are significantly higher than their running current. These higher starting currents may cause the circuit breaker to open. (See next paragraph)
- Both the receptacle circuits are protected from shorts and overloads by a 15 amp circuit breaker, located above the receptacle. If the breaker trips its button pops out exposing a red ring. When the circuit breaker cools the button can be reset by pressing it back in.

**Note:** When the breaker trips not only will the auxiliary and cooler power be interrupted, but so will the power to the shielding gas solenoid and machine cooling fan.

The Precision TIG **Export models** also provide a grounded 220 VAC Euro type Schuko receptacle and a 5 amp circuit breaker, located on the upper case back on the reconnect side of the machine, intended for use with a 220 VAC water cooler.

## REMOTE CONTROL (If Used)

The Foot Amptrol (included with the Precision TIG Welding Package), or other Remote accessory, is installed by routing the plug of its control cable up through the left cable strain relief hole provided in the base (see Figure A.2), then connecting the 6-pin plug to the mating Remote receptacle behind the stud panel cover. (See Operation Section B-2 for mating plug wiring.)

**Note:** If the Precision TIG is equipped with an Under-Cooler or Under-Storage unit, the Foot Pedal (or other remote control accessory) and coiled control cable, or excess cable length, may be conveniently stored in the drawer while remaining connected.

PRECISION TIG 275



### ROBOTIC INTERFACE CONNECTION

Robotic interface can be made at the Remote Receptacle (See **Operation Section**). The machine is shipped with the remote receptacle circuit internally connected to receptacle J5 of the Control board for standard Amptrol operation. In order to enable the remote receptacle for robotic interface its connection plug must be moved from J5 to J5A on the Control board. (Refer to the machine Wiring Diagram.)

The robotic interface functions with the Precision TIG set to either TIG or STICK mode, but must be in REMOTE switch position for the Preset Control interface to function. When in the REMOTE position with robotic interface neither the MAXIMUM OUTPUT nor the MINIMUM OUTPUT panel controls limit the interface control setting over the rated output range of the machine.

The diagram in Figure A.4 below shows the remote receptacle plug connections and signals for robotic interface:

FIGURE A.4

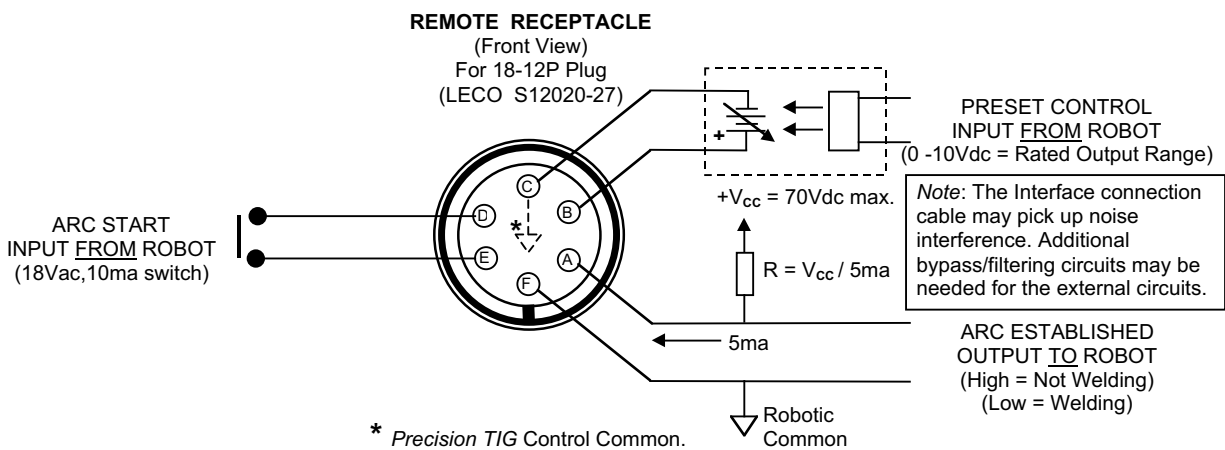

PRECISION TIG 275



Return to Section TOC

Return to Section TOC

Return to Section TOC

Return to Section TOC

Return to Master TOC

Return to Master TOC

Return to Master TOC

Return to Master TOC



Return to Section TOC

Return to Section TOC

Return to Section TOC

Return to Section TOC

Return to Master TOC

Return to Master TOC

Return to Master TOC

Return to Master TOC

PRECISION TIG 275



# TABLE OF CONTENTS - OPERATION SECTION -

---

<b>Operation</b> .....	<b>Section B</b>
Safety Precautions .....	B-2
Product Description .....	B-2
Recommended Process and Equipment .....	B-3
Controls and Settings .....	B-4
Welding Operation .....	B-5/B-8
Internal Set Up Controls .....	B-9
2 Step Trigger Modes .....	B-10
4 Step Trigger Modes .....	B-11
TIG Weld Cycle Chart .....	B-12
Set Up for TIG Amptrol Welding .....	B-13
Making a TIG Weld with an Amptrol .....	B-14
Recommended Electrode Amperage Ranges .....	B-14

Return to Master TOC

Return to Master TOC

Return to Master TOC

Return to Master TOC

PRECISION TIG 275



## SAFETY PRECAUTIONS

Read and understand this entire section before operating the machine.

### WARNING



#### **ELECTRIC SHOCK CAN KILL.**

- \* Only qualified personnel should perform the installation.
- \* Turn the input power OFF at the disconnect switch or fuse box.
- \* Do not touch electrically live parts or electrode with skin or wet clothing.
- \* Insulate yourself from work and ground.
- \* Always dry insulating gloves.
- \* Read and follow "Electric Shock Warnings" in the Safety section if welding must be performed under electrically hazardous conditions such as welding in wet areas or on or in the workpiece.

#### **FUMES AND GASES**

can be dangerous.

- \* Keep your head out of fumes.
- \* Use ventilation or exhaust to remove fumes from breathing zone.



#### **WELDING SPARKS**

can cause fire and explosion

- \* Keep flammable material away.
- \* Do not weld on containers that have held combustibles.

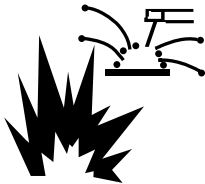

#### **ARC RAYS**

can burn.

- \* Wear eye, ear and body protection.



Observe additional Safety Guidelines detailed in the beginning of this manual.

## PRODUCT DESCRIPTION

The Precision TIG 275 is part of a new family of industrial arc welding power sources providing constant current, single range square wave AC/DC TIG (GTAW) with new patented (pending) Micro-Start™ Technology, Presettable Min. and Max. Output controls, and built-in high frequency stabilization for continuous AC TIG and DC TIG starting. It also has AC/DC Stick (SMAW) capability, with adjustable Arc Force availability. A TIG Pulse Panel. Power Factor Capacitors and a Water Solenoid are available as field installed optional kits. Also, a new Undercarriage (with double gas bottle rack) is available for field installation, as well as a new Under-Cooler Cart, which is also included in an available efficiently integrated entire TIG Welding Package with convenient built-in storage provisions for welding equipment and components.

The Precision TIG 275 includes advanced features such as a Digital Meter, Presettable control, Auto Balance™, Fan As Needed (F.A.N.) fixed Preflow, variable Postflow shielding gas and Timers. In addition, 2-Step/4-Step and Pulse TIG operation with adjustable Downslope Time control are included with an available field installed kit. It also features a Stick stud panel and a universal TIG torch connection box for simultaneous, but separated, electrode outputs.

The Precision TIG 275 has enhanced Features which includes the following:

- MicroStart™ Codes Below 11000
- MicroStart™ II Codes Above 11000
- Auto-Balance optimized
- Menu button added
- Spot On selection added

## PIPE THAWING

The Precision TIG 275 is not recommended for pipe thawing.

## Duty Cycle

The duty cycle is based upon a 10-minute time period; i.e., for 40% duty cycle, it is 4 minutes welding and 6 minutes idling. If the rated duty cycle is significantly exceeded, the thermostatic protection will shut off the output until the machine cools to a normal operating temperature. (Refer to Specification Section A-1)

**RECOMMENDED PROCESSES AND EQUIPMENT**

**RECOMMENDED PROCESSES**

The Precision TIG 275 is recommended for the TIG (GTAW) and Stick (SMAW) welding processes within its output capacity range of 2 amps DC, or 5 amps AC, to 340 amps AC/DC. It is compatible with most Magnum TIG accessories (refer to Equipment Limitations), as well as many industry standard items, such as TIG torches, hoses, and water coolers.

**PROCESS LIMITATIONS**

Precision TIG machines are not recommended for arc gouging due to it's limited output capacity, and are also not recommended for pipe thawing.

**EQUIPMENT LIMITATIONS**

The Precision TIG machines are protected from overloads beyond the electrical ratings and duty cycles, per the Specifications Section A-2, A-3, with Thermostat protection of the primary and secondary transformer coils.

The Precision TIG machines do not have Hi-Freq. available at the Stick electrode stud, therefore stud connection adapters (such as LECO. S19257-series) cannot be used for torch connection.

**RECOMMENDED EQUIPMENT/INTERFACE FOR CODES ABOVE 11000**

Machine:	<u>TIG (water cooled)</u> PT275 Welding Package (K2618-1)	<u>TIG (air cooled)</u> PT275(K2619-1, -2)
Input Cable/Clamp:	User provided	User provided
Gas Reg./Hose:	(included)	LE/Harris 3100211
Magnum Torch:	(PTW20 included)	PTA9 or PTA17
Magnum Parts:	(KP510 and K918-2 included)	KP507 or KP508
Work Clamp/Lead:	(15 ft. included)	K2150-1 Work Lead Assembly
Foot Amptrol:	(K870 included)	K870

**RECOMMENDED EQUIPMENT/INTERFACE FOR CODES BELOW 11000**

Machine:	<u>TIG (water cooled)</u> PT275 Welding Package (K1825-1)	<u>TIG (air cooled)</u> PT275(K1826-1, -2, K1827-1)
Input Cable/Clamp:	User provided	User provided
Gas Reg./Hose:	(included)	LE/Harris 3100211
Magnum Torch:	(PTW20 included)	PTA9 or PTA17
Magnum Parts:	(KP510 and K918-2 included)	KP507 or KP508
Work Clamp/Lead:	(15 ft. included)	K2150-1 Work Lead Assembly
Foot Amptrol:	(K870 included)	K870 or K870-1

PRECISION TIG 275



Return to Section TOC

Return to Section TOC

Return to Section TOC

Return to Master TOC

Return to Master TOC

Return to Master TOC

## CONTROLS AND SETTINGS

The Front Control Panel contains the knobs and switches necessary for adjusting the operation of the Precision TIG 275, with function indicator lights and an electronic display for volts and amps. The components are described below:

FIGURE B.1 - CONTROL PANEL

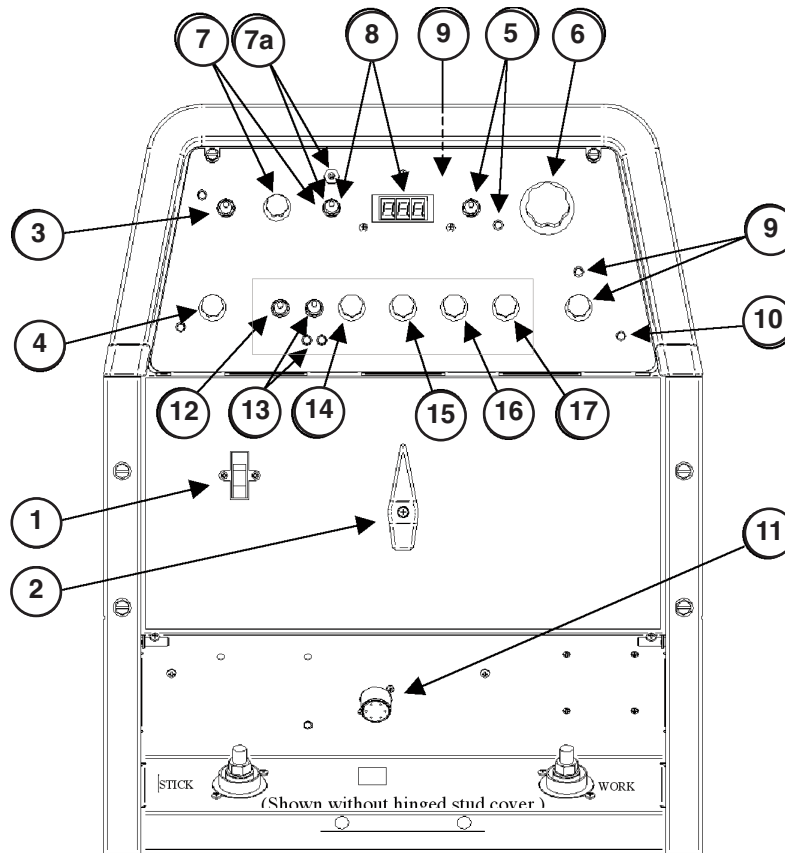

1. POWER SWITCH
2. POLARITY SWITCH
3. MODE SWITCH
4. AC BALANCE CONTROL
5. LOCAL/REMOTE CURRENT CONTROL SWITCH
6. MAXIMUM OUTPUT CONTROL
7. MINIMUM OUTPUT CONTROL AND DISPLAY SWITCH
- 7.a MENU BUTTON AND DISPLAY SWITCH FOR CODES ABOVE 1100
8. DIGITAL METER AND DISPLAY SWITCH
9. POSTFLOW TIME
10. THERMAL SHUTDOWN LIGHT
11. REMOTE RECEPTACLE
12. TRIGGER SWITCH
13. PULSE MODE SWITCH
14. PULSE FREQUENCY CONTROL
15. PULSE % ON TIME CONTROL
16. PULSE BACKGROUND CURRENT CONTROL
17. DOWNSLOPE TIME

**1. POWER SWITCH** - Input line switch turns input power ON or OFF, as indicated by the on or off status of the front panel displays.

**2. POLARITY SWITCH** - The 3-position rotary power switch has detente positions for DC-, AC and DC+ selections for the Electrode output welding polarity.

**3. MODE SWITCH** - The mode switch allows vertically positioned selection of the two machine welding modes. The selected mode is indicated by a lit colored panel light which permits viewing the machine setting from a distance:

**3.a STICK mode** (Top position) -Red panel light

### ⚠ WARNING



**ELECTRIC SHOCK can kill.**  
 • When the Power Source is ON in STICK mode the Electrode circuits of both the Stick and TIG torch cables are electrically HOT to Work.

• The CC Stick mode may be used for general purpose stick welding (SMAW) within the capacity of the machine. The capacity is too limited for air carbon arc gouging (CAC-A).

• In this mode; the output terminals are activated electrically HOT, gas flow is not activated and HOT START and ARC FORCE levels are fixed, or Advanced Panel selectable (See Section B-7), with no front panel adjustment.

**3.b TIG mode** (Bottom position) - No panel light.

• When the Polarity Switch is set to AC, the TIG mode provides continuous high frequency to stabilize the arc for AC TIG welding.

• Hi-Freq. turns on after preflow time with the arc start switch closure, and turns off when the arc goes out\* after the arc start switch opens.

\* Arc voltage and current are sensed to determine if the arc is established or out.

PRECISION TIG 275

- When the Polarity Switch is set to DC (- or +), the TIG mode provides high frequency only for starting.
- Hi-Freq. turns on after pre-flow time with the arc start switch closure, and turns off when the arc is established\*
- DC+ polarity can also be used for "balling" of the tungsten for AC TIG welding.

**4. AC BALANCE CONTROL** – The potentiometer control permits AC wave balance adjustment from Max. Penetration (~85% negative wave) with the control at Max. full CW position, to Max. Cleaning (~65% positive wave) with the control set near minimum CCW position.

- Full minimum CCW position is the Auto Balance position which is indicated by the Green panel light turning on. This feature automatically provides the proper amount of cleaning and penetration for normal AC TIG welding
- The mid position is the Balanced position (~50% positive and negative waves).
- The Balance control is only functional if the machine is set to AC polarity and TIG mode.

**5. LOCAL/REMOTE CURRENT CONTROL SWITCH** – A 2-position switch selects how the welding output is controlled for both Stick and TIG Modes:

- LOCAL (Top position) selects output control only by the machine panel Output Control. (See Item 6)
- REMOTE (Bottom position) selects output control to also be by an Amptrol (See Item 6), or other remote (10K pot) control connected to the Remote receptacle (See Item 11) This switch selection is indicated by the Green panel light turning on.

In either position the arc start switch functions when connected to the Remote receptacle (See Item 11).

**6. MAXIMUM OUTPUT CONTROL** – The large knob is used to set the output welding current over the rated output range of the machine.

- With the Current Control switch to LOCAL position, this knob sets the welding output level.

- With the Current Control switch to REMOTE position, this knob sets the maximum welding level that the Peak output can be set with the remote Amptrol.
- The new MicroStart™ Technology minimum current circuit provides for low end welding (down to 2 amps) previously unobtainable on an SCR platform TIG machine.

#### **7. MINIMUM OUTPUT CONTROL AND DISPLAY SWITCH**

A smaller knob is used to preset the minimum current level only for TIG mode. Pressing the Display (momentary) switch toggle left to Minimum Set position displays the Minimum control level setting on the Digital meter. (See Item 8)

- This knob sets the Start output level. When the arc lights (using a new built-in TIG start pulse) this level upslopes quickly (0.5 sec.w/ Advanced Panel, zero w/o) and smoothly to the weld output level. The setting range for this Start control is the 2 amp minimum range of the machine up to about 50 amps, but no more than the level set by the Maximum Output control knob (See Item 6), but otherwise is independent of the Maximum setting.
- This setting also serves as the Crater-fill level, but with a Precision TIG Advanced Panel it can be selected (see Section B-7) to be either the Minimum Output control setting (same as Start setting) as shipped, or the minimum rating of the machine (2 amps).
- The Remote Amptrol range of control is between this Minimum setting and the Maximum Output control knob setting, so these knobs can set the resolution of the Amptrol. Also, the Minimum setting serves as both the minimum Amptrol start level when the arc start switch is closed, as well as the minimum Amptrol crater-fill level before the arc start switch is opened to help prevent premature arc out and Hi-Freq re-initiation.
- In STICK mode the Start control is not functional since Hot Start level is fixed, or internal Advanced Panel adjustable (see Section B-7). Pressing the Display (momentary) switch toggle left to Minimum Output position displays minimum amps rating of the machine.

**7a MENU BUTTON AND DISPLAY SWITCH (Codes above 11000)** – Pressing and holding the **(Menu)** Button for about 5 seconds *enters* the menu display which allows:

- *Selection* of up to seven programmable parameters (Preflow, Upslope, Hot Start, Arc Force, etc.) on the digital meter is achieved by momentarily pressing and releasing the **MENU** button to step through the parameters.
- *Setting* of the desired level, displayed on the digital meter for the selected parameter, is done by pressing the **DISPLAY** (momentary) switch toggle to the right to increase the level setting, or to the left to decrease it.

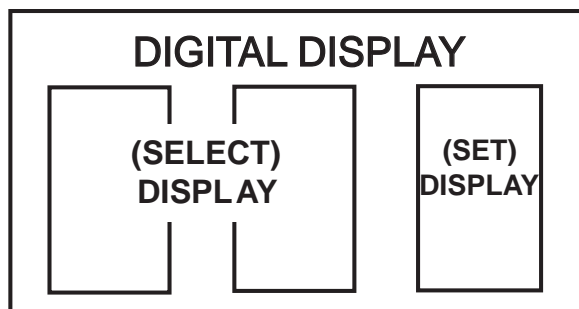

TIG Mode Menu	
Setting:	Description:
Selection 1: <b>HF</b> (High Freq.)	
0	Scratch start TIG (No Hi-Freq.)
1 *	Normal Hi-Freq. start and weld
2	Lift TIG (Touch start w/o Hi-Freq.)
Selection 2: <b>PF</b> (Preflow time)	
0	No Preflow
1	0.1 sec.
2 *	0.5 sec.
3	1.0 sec.
4	1.5 sec.
5	2.0 sec.
Selection 3: <b>SS</b> (MicroStart™ Start Pulse)	
0 *	No AC pulse/Low DC pulse (soft start)
1	High AC/DC pulse (forceful start)
2	<b>HS</b> setting (see below) for each pulse when Pulse mode welding anodized aluminum.
Δ	
* Default Factory Setting. (Indicated by "blinking" decimal point.)	
Δ Only selectable with Advanced Control Panel installed.	

TIG Mode Menu (with Advanced Control Panel installed):	
Setting:	Description:
Selection 4: <b>HS</b> (TIG Hot Start % of output setting)	
0 *	+0% (Only setting for <b>SS0</b> , above.)
1	+10%
2	+20%
3	+30%
4	+40%
5	+50%
6	+60%
7	+70%
8	+80%
9	+90%
Selection 5: <b>UP</b> (Upslope Time)	
0	None (Only setting for <b>SS1</b> & <b>SS2</b> , above.)
1*	0.5 sec.
2	1.0 sec.
3	1.5 sec.
4	2.0 sec.
5	2.5 sec.
* Default Factory Setting. (Indicated by "blinking" decimal point.)	

STICK Mode Menu (with Advanced Control Panel installed <sup>◇</sup> ):	
Setting:	Description:
Selection 6: <b>HS</b> (Stick Hot Start % added to output setting)	
0	+0%
1	+10%
2	+20%
3	+30%
4	+40%
5 *	+50%
6	+60%
7	+70%
8	+80%
9	+90%
Selection 7: <b>AF</b> (Stick Arc Force % added to output setting)	
0	+0% ("Softer" arc)
1 *	+10%
2	+20%
3	+30%
4	+40%
5	+50%
6	+60%
7	+70%
8	+80%
9	+90% ("Crisper" arc)
* Default Factory Setting. (Indicated by "blinking" decimal point.)	
◇ If no Advanced Control Panel the Stick menu displays "--".	

• Any of the following actions will **exit** the menu display:

1. Pressing and holding the **(Menu)** Button again for about 5 seconds.
2. Allowing the menu display to be unchanged for about 15 seconds.
3. Closing the arc start switch (TIG Mode) or starting the arc (Stick Mode).

Note: In Stick Mode the machine output will remain on while in menu display.

• **Re-entering** the menu displays the last parameter and setting that was displayed when the menu was **exited**.

• All settings may be reset to the Factory Default Settings (above) by holding the **(Menu)** button pressed while turning on the machine's **Power** switch. The display will show "**res**" to indicate the defaults are reset.

Return to Section TOC

Return to Master TOC



**8. DIGITAL METER AND DISPLAY SWITCH**— A 3-digit LED meter is used to monitor the preset and actual welding procedure based on the Display (momentary) switch position:

- Before welding with Display switch in center (normal) position, the digital meter displays the preset welding amps set by Maximum Output control knob (See Item 6). If in Stick mode using REMOTE (See Item 5.), the digital meter displays the preset welding amps set by the Remote control. (See Item 11)
- While welding with Display switch in center (normal) position, the digital meter displays the actual welding amps with one amp resolution (XXX) and accuracy within 4%+/-2A of reading.
- At any time in TIG mode, pressing the Display switch to left causes the digital meter displays the amps preset by the Minimum Output control knob (See Item 7).
- At any time in Stick mode, pressing the Display switch to left causes the digital meter to display the minimum amps rating of the machine (See Item 7).
- In either mode, while pressing the Display switch right to Volts position, the digital meter displays actual output volts. Volts is displayed with 0.1 volt resolution (XX.X) and accuracy within 3%+/-1V of reading.

**9. POSTFLOW TIME** – This knob is used to set the TIG mode shielding gas postflow time over the range of about 2 to 60 seconds after the arc is shut off. The postflow on time status is indicated by the Green panel light.

- Gas preflow time for TIG mode is fixed at 0.5 seconds, with no panel control.
- Both time ranges are x2 extendable, if needed, by internal control box selection. (See Section B-7)

**10. THERMAL SHUTDOWN LIGHT** – This yellow LED panel light turns on if the machine output is shut-down because internal overheating has occurred, and turns off when the thermostat resets.

**11. REMOTE RECEPTACLE** – A 6-socket receptacle is provided for the connection of an Amptrol, or other remote control: (See Figure B.2)

- When the Current Control Switch (See Item 5) is in the REMOTE position, the Amptrol or other remote (10K pot) connected to the Remote receptacle controls the TIG or Stick mode output within the range preset by the Maximum and Minimum Output controls. (See Item 6, 7, and 8 for meter display.)

- When the Current Control Switch is in either LOCAL or REMOTE positions the arc start switch functions when connected to the Remote receptacle.

**FIGURE B.2**

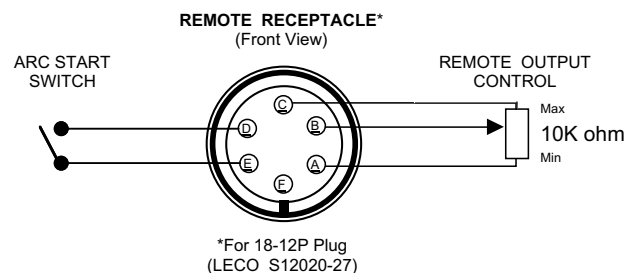

## ADVANCED PANEL CONTROLS

The following controls are included only if the Precision TIG 275 has the Advanced Control Panel (K1829-1) option installed: (Refer to **Figure B.3** Tig Weld Cycle Chart for graphic illustration of these TIG welding functions.)

**12. TRIGGER SWITCH** – This 2-position switch selects how the arc start switch (connected to the above Remote receptacle) functions; in 2-Step or 4-Step mode:

### ⚠ CAUTION

- **DO NOT USE 4-STEP IF USING AN AMPCTRL REMOTE.**
- **Neither the arc start switch nor the output control in the amptrol will function normally to shut off or control the output. ONLY USE 2-STEP.**

• In 2-Step position the arc start switch functions the same as without the Advanced Panel:

1. Closing switch starts preflow, then a fixed (0.5 sec.) ramp time from Minimum (Start) setting level (See Item 7) to Weld setting.
2. Opening switch initiates Downslope ramp time setting (See Item 17), from Weld setting to Crater-fill level (See Item 7), which then stops the arc and initiates Postflow time (See Item 9).

**Note:** See **Figure B.3** for 2-Step operation during Downslope with Restart feature selected to be disabled, instead of enabled (as shipped).



## INTERNAL SET UP CONTROLS

Precision TIG 275 models which have an Advanced Panel (K1829-1) option installed\* have the following additional control features which are set up using the DIP Switch (S1) provided on the internal panel of this option.

Access to this internal panel is obtained by removing the two screws securing the top corners of the Precision TIG front control panel and swinging the control panel down to reveal the panel mounted on the surface of the Precision TIG Control board:

### ⚠ CAUTION

- THE CONTROL BOARDS CONTAIN STATIC SENSITIVE COMPONENTS
- To avoid possible damage to these components be sure to ground yourself by touching the machine's sheet metal while handling or making settings on the internal control box components.

#### PRECISION TIG ADVANCED PANEL (Internal Panel)

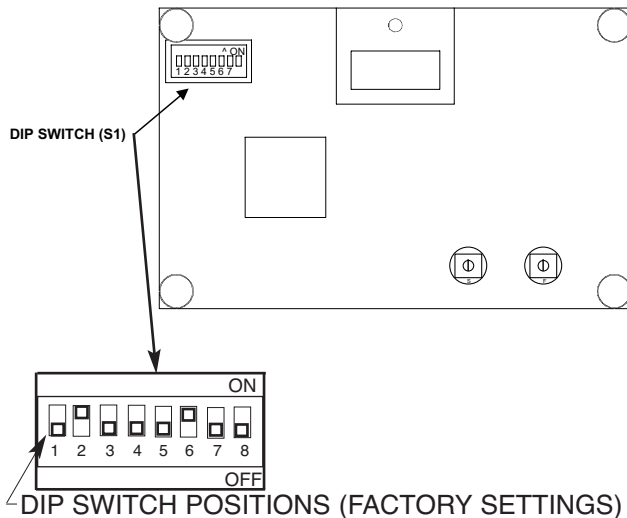

## STICK WELDING FEATURES

The following DIP switch feature selections function only when the Precision TIG is set to Stick mode. (See Item 3):

- **Switch #6 Hot Start Level (codes below 11000)** – Provides an extra output "boost" pulse at the arc strike to enhance arc starting. This is factory set for a level (about 50% extra) which is usually good for most stick welding applications

**ON** – Hot Start level is used (as shipped).  
**OFF** – No Hot Start.

- **Switch #7 Arc Force Level (codes below 11000)**– Prevents "sticking" of the electrode by providing extra output current if the arc voltage drops below the level required to sustain the welding arc. High (+65%) and Low (+12%) factory set levels are selectable which are good for most stick welding applications.

**ON** – Higher for a "crisper" arc, often desired for 6010 type electrodes.  
**OFF** – Lower Arc Force (as shipped) for a "softer" arc with 7018 or general type electrodes.

- **Switch #6 & #7 - Not functional on codes above 11000 - See item 7a for adjustment of Hot Start and Arc Force**

- **Switch #8 - (NOT CURRENTLY FUNCTIONAL)**

## TIG WELDING FEATURES

The following DIP switch feature selections function only when the Precision TIG is set to TIG mode (See Item 3):

- **Switch #1 Preflow/Postflow Time Extension\*** (See Item 9)

**ON** – Doubles the time ranges.  
**OFF** – Standard time ranges (as shipped).

- **Switch #2 2-Step Trigger Restart Feature** (See Figure B.3)

**ON** – Restart Enabled (as shipped).  
**OFF** – Restart Disabled.

- **Switch #3 4-Step Trigger Restart Feature** (See Figure B.4)

**ON** – Restart Enabled.  
**OFF** – Restart Disabled (as shipped)

- **Switch #4 (NOT CURRENTLY FUNCTIONAL)**

- **Switch #5 Crater-Fill Level** (See Item 7)

**ON** - Level is minimum rating of the machine (2A)  
**OFF** – Level (as shipped) is Minimum Output setting (same as Start level).

\* The Preflow/Postflow Time doubling feature can also be selected on Precision TIG 275 models without the Advanced Panel by accessing the Control board in the control box per above instructions, then disconnecting the jumper terminals attached to the jumper plug connected to receptacle J3 of the Control board. (Refer to Machine Wiring Diagram.)

PRECISION TIG 275



FIGURE B.3

### 2 Step Trigger Modes

- ..... START/CRATER CURRENT
- ..... UP-SLOPE
- DOWN-SLOPE

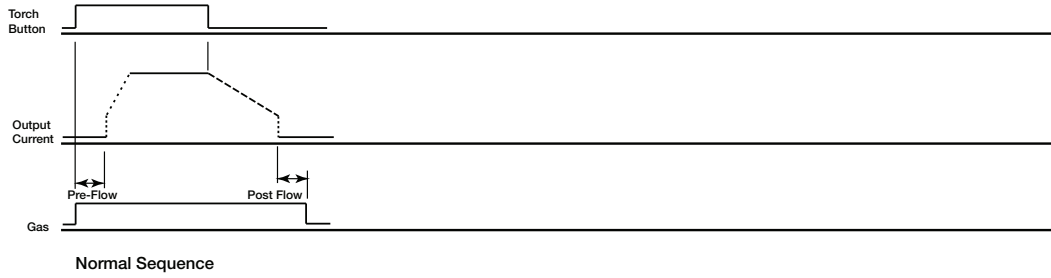

### 2 Step - Restart Disabled (With DIP Switch #2 OFF)

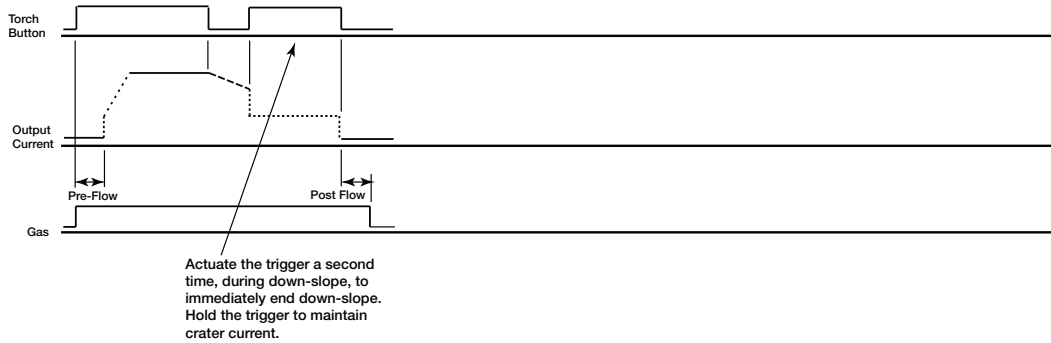

### 2 Step - Restart Enabled (With DIP Switch #2 ON. As Shipped)

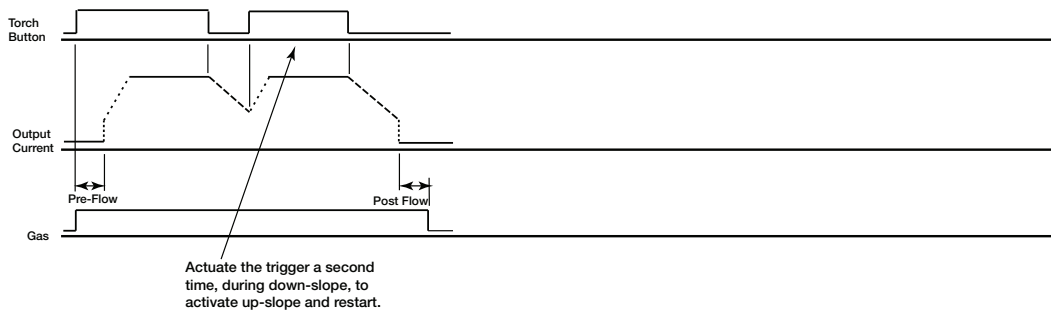

2 Step.aps  
12-17-07  
JRM

Return to Section TOC  
 Return to Section TOC  
 Return to Section TOC  
 Return to Section TOC  
 Return to Master TOC  
 Return to Master TOC  
 Return to Master TOC  
 Return to Master TOC

FIGURE B.4

### 4 Step Trigger Modes

..... START/CRATER CURRENT  
 ..... UP-SLOPE  
 ----- DOWN-SLOPE

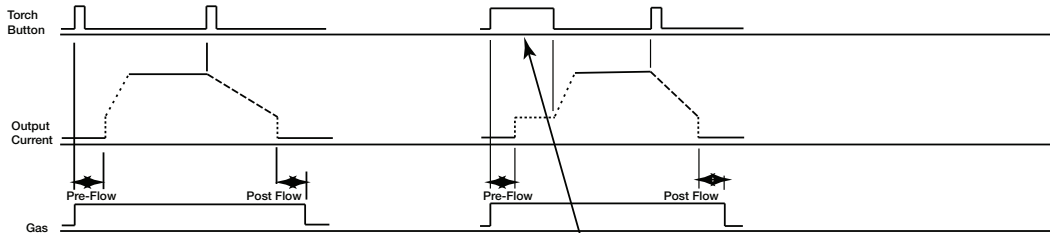

Normal Sequence

Hold the first trigger pull to maintain the starting current and delay up-slope.

### 4 Step - Restart Enabled (With DIP Switch #3 ON)

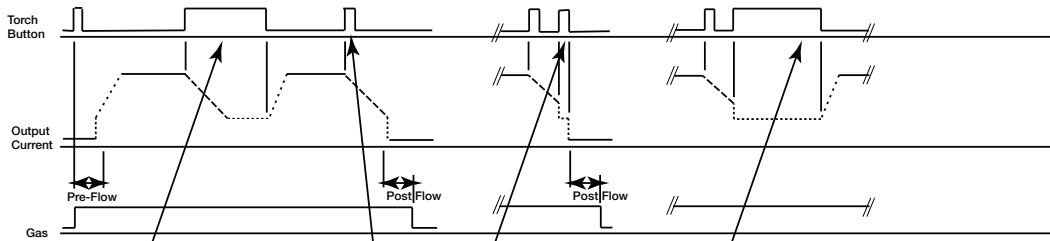

Hold the second trigger pull for more than 1 second to activate the restart function. When the trigger is released up-slope will occur.

Actuate the trigger holding it less than 1 second, to begin normal down-slope. The following two options are available during the normal down-slope period.

Actuate the trigger again, during down-slope, to immediately end down-slope and stop.

Or actuate and hold the trigger, during down-slope, to immediately end down-slope and maintain crater current. Hold the trigger for more than 1 second to activate the restart function. When the trigger is released up-slope will occur.

### 4 Step - Restart Disabled (With DIP Switch #3 OFF. As Shipped)

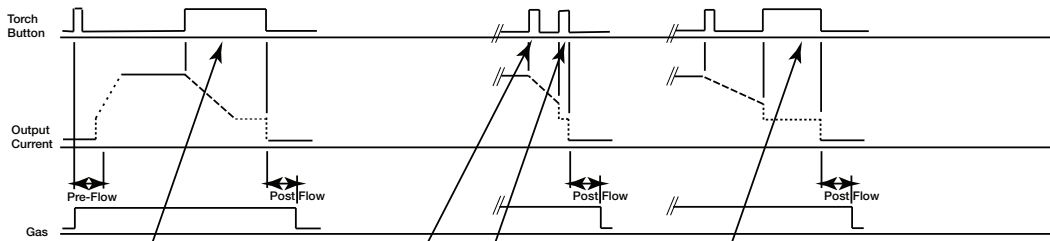

Hold the second trigger pull for more than 1 second to maintain crater current before stopping.

Actuate the trigger holding it less than 1 second, to begin normal down-slope. The following two options are available during the normal down-slope period.

Actuate the trigger a third time, during down-slope, to immediately end down-slope and stop.

Or actuate the trigger a third time, during down-slope, to immediately end down-slope. Hold the third trigger pull to maintain crater current.

4 Step.oss  
12-17-07  
JRM

PRECISION TIG 275



Return to Section TOC  
 Return to Section TOC  
 Return to Section TOC  
 Return to Master TOC  
 Return to Master TOC  
 Return to Master TOC

TIG WELD CYCLE CHART

CODES BELOW 11000 (K1829-1)

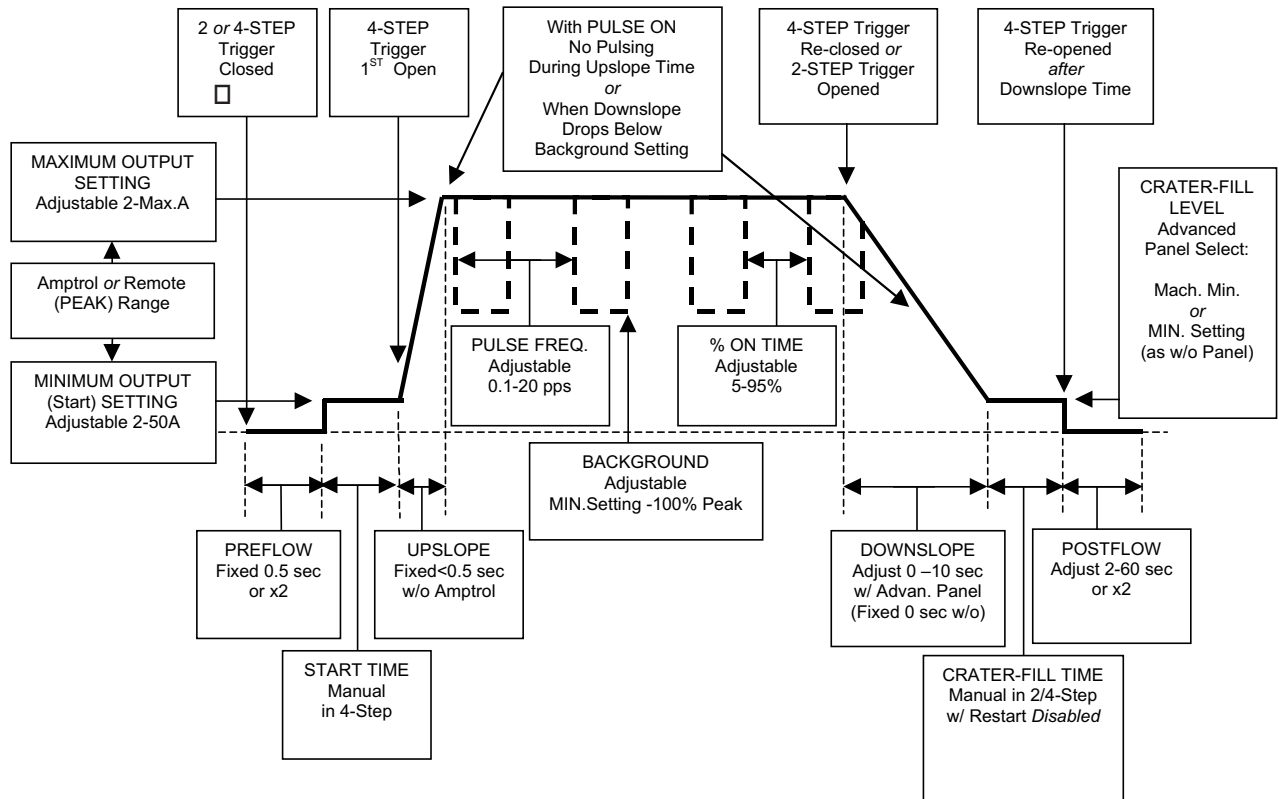

CODES ABOVE 11000 (K2621-1)

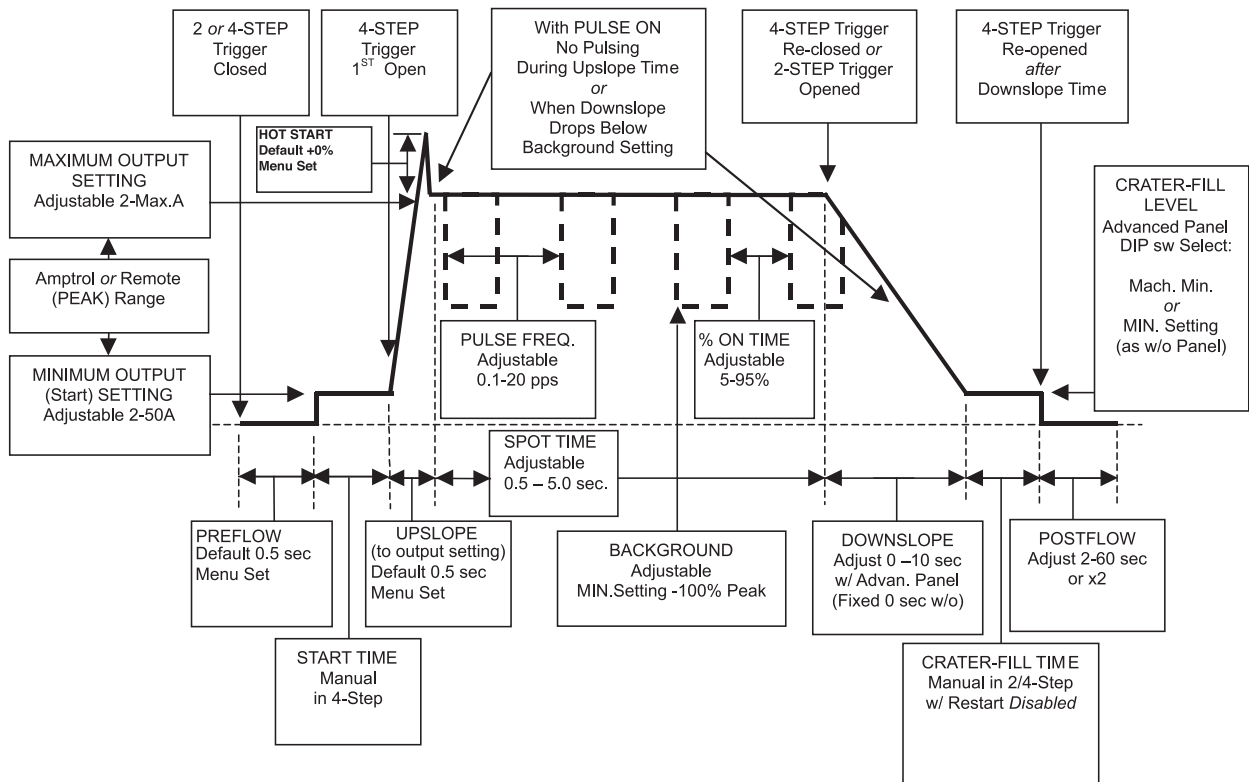

PRECISION TIG 275



Return to Section TOC

Return to Section TOC

Return to Section TOC

Return to Section TOC

Return to Master TOC

Return to Master TOC

Return to Master TOC

Return to Master TOC

FIGURE B.6

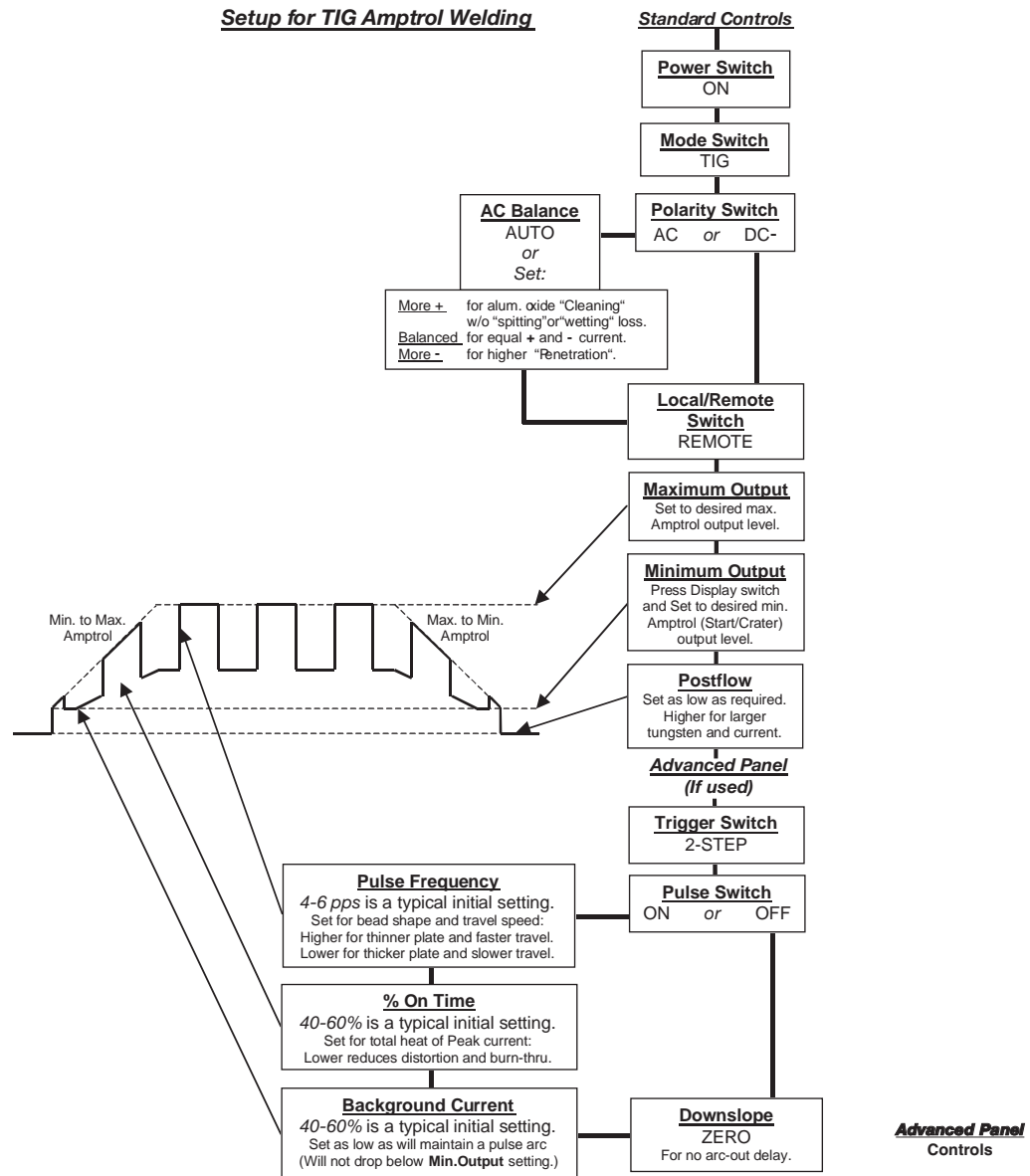

## SETUP GUIDELINES FOR TIG WELDING WITH AN AMPCTRL

Both the Hand and Foot **Ampctrls** work in a similar manner. They are meant to be used for remote current control for TIG welding using the machine's **2-Step** trigger mode (See Item 12).

The Ampctrl is capable of controlling the output of the Precision TIG over the range between the level preset by the **Minimum Output** control when the Ampctrl is at its inactivated state, and the level preset by the **Maximum Output** control when the Ampctrl is at fully-activated state.

It is important to note that even with the Precision TIG's new **MicroStart™** Technology, some tungsten may be difficult to start at the low (2 amps) minimum rating of the machine. Rather than guessing where to depress the Ampctrl to start the arc reliably, the **Minimum Output** control allows presetting the exact level, so reliable starts, as well as minimum crater-fill levels, can be consistently obtained at the minimum Ampctrl (inactivated) state. FIGURE B.6 shows Precision TIG setup for TIG welding with an Ampctrl.

PRECISION TIG 275





**MAKING A TIG WELD WITH AN AMPCTRL**

1. Install welding equipment per Section A-5.
2. Setup controls per Section B-9.
3. Turn on the shielding gas supply, and torch coolant input supply (if used).

**Note:** The Precision TIG Under-Cooler (or Water Solenoid connected to the Cooler receptacle) runs with the Fan-As-Needed machine cooling fan (See Maintenance Section D), so the cooler fan and water pump will also not run continuously in idle, but will run while welding.

4. With the torch held safely away from everything, close the Arc Start Switch of the Ampctrl and set the gas flow meter. Then open the switch. The welder is now ready for welding.
5. Position the tungsten electrode at the start of the weld at a 65° to 75° angle with the horizontal, in the direction of pushing travel, so that the electrode is approximately 1/8" (4 mm) above the work piece.

Close the arc start switch. This opens the gas valve to automatically purge air from the hose and torch, then shields the arc strike area. After the 0.5 second preflow time, the high frequency becomes available to strike the arc. When the arc strikes the torch coolant (if used) starts to flow. Also, if welding DC- TIG, the high frequency shuts off just after the arc strikes.

6. Hold the arc start switch closed at minimum Ampctrl Start level (See Section B-10) until an arc is established, then increase the output to the desired welding level and push the torch in the direction of travel.
7. At the end of the weld, decrease the Ampctrl output to the crater-fill level before releasing the arc start switch to start the Postflow time. Hold the torch gas shielding over the solidifying weld crater while post-flow time expires and the gas valve reopens. The torch coolant (if used) continues to flow for up to 8 minutes after the arc goes out (with the Fan-As-Needed feature) to assure torch cooling.
  - Repeat steps 5 through 7 to make another weld.

**RECOMMENDED ELECTRODE AMPERAGE RANGES - PRECISION TIG 275**

**SMAW Process**

ELECTRODE	POLARITY	3/32"	1/8"	5/32"
Fleetweld 5P, Fleetweld 5P+	DC+	40 - 70	75 - 130	90 - 175
Fleetweld 180	DC+	40 - 80	55 - 110	105 - 135
Fleetweld 37	DC+	70 - 95	100 - 135	145 - 180
Fleetweld 47	DC-	75 - 95	100 - 145	135 - 200
Jet-LH MR	DC+	85 - 110	110 - 160	130 - 220
Blue Max Stainless	DC+	40 - 80	75 - 110	95 - 110
Red Baron Stainless	DC+	40 - 70	60 - 100	90 - 140

Mild steel procedures are based on recommended procedures listed in C2.10 8/94 and the maximum rating of the PRECISION TIG 275  
 Excaliber 7018 procedures are based on Jet-LH 78 MR  
 Blue Max procedures are based on C6.1 6/95  
 Red Baron Procedure are based on ES-503 10/93

**GTAW Process**

Electrode Polarity		DC-		AC*		Approximate Argon Gas Flow Rate C.F.H. (l/min.)	
Electrode Tip Preparation		Sharpened		Balled			
Electrode Type		EWTh-1, EWCe-2 EWTh-2, EWLa-1 EWG		EWP	EWZr EWTh-1, EWTh-2 EWCe-2, EWLa-1 EWG	Aluminum	Stainless Steel
Electrode Size (in.)							
.010		Up to 15 A.		Up to 15 A.	Up to 15 A.	3-8 (2-4)	3-8 (2-4)
.020		Up to 15 A.		10 to 15 A.	5 to 20 A.	5-10 (3-5)	5-10 (3-5)
.040		Up to 80 A.		20 to 30 A.	20 to 60 A.	5-10 (3-5)	5-10 (3-5)
1/16		Up to 150 A.		30 to 80 A.	60 to 120 A.	5-10 (3-5)	9-13 (4-6)
3/32		Up to MAX. A.		60 to 130 A.	100 to 180 A.	13-17 (6-8)	11-15 (5-7)
1/8		X		100 to 180 A.	160 to 250 A.	15-23 (7-11)	11-15 (5-7)

Tungsten electrodes are classified as follows by the American Welding Society (AWS):

- Pure .....EWP.....green
- +1% Thoria .....EWTh-1.....yellow
- +2% Thoria .....EWTh-2.....red
- +2% Ceria.....EWCe-2.....orange
- +1.5% Lanthana .....EWLa-1.....black
- +0.15 to 0.40% Zirconia .....EWZr.....brown

Ceriated Tungsten is now widely accepted as a substitute for 2% Thoriated Tungsten in AC and DC applications.  
 Balanced Wave, Unbalanced Wave requires derating of the electrode.

**PRECISION TIG 275**



Return to Section TOC

Return to Master TOC

# TABLE OF CONTENTS - ACCESSORIES -

---

<b>Accessories</b> .....	<b>Section C</b>
Optional Equipment for Codes Below 11000.....	C-2
Optional Equipment for Codes Above 11000.....	C-3

Return to Master TOC

Return to Master TOC

Return to Master TOC

Return to Master TOC

PRECISION TIG 275



## OPTIONAL EQUIPMENT

### FACTORY INSTALLED OPTIONS

The basic Precision TIG 275 machine is factory equipped with:

- A 3/8" Adapter (S20403-4) for air cooled torch connection of a PTA-9 or PTA-17.

Accessories that are factory installed with the Domestic model (K1826-1) to make up the Domestic Welding Package (K1825-1) include:

- K1828-1 Under-Cooler Cart
- 3100211 Harris Argon Flow Regulator with 10' Hose.
- K870 Foot Amptrol
- K1784-4 25' PTW-20 water-cooled TIG Torch
- K918-2 Zippered Torch Cover
- KP510 Parts Kit for Torch
- K2150-1 Work Lead Assembly

See below for more detailed descriptions.

### FIELD INSTALLED OPTIONS

The following Options/Accessories are available for the Precision TIG 275 and are installed per instructions in this manual and / or provided in the package:

- K1829-1 Precision TIG Advanced Control Panel Provides 2/4-step trigger with adjustable Pulser controls and Down slope timer for TIG welding. Also includes adjustable Hot Start and Arc Force internal panel controls for Stick welding, and other user selectable features.
- K1828-1 Under-Cooler Cart Includes a "cooler-in-a-drawer" with hoses and a lockable storage drawer on a dual bottle undercarriage (see below).
- K1869-1 Undercarriage Includes a dual bottle rack with chain and an undercarriage with 5" front casters, 10" rear wheels and a handle.
- K1830-1 Water Solenoid Kit Provides for stopping flow of external water supply. Connects to coolant inlet and cooler receptacle of Precision TIG. (Cannot be used with a water cooler.)

- K870 Foot Amptrol  
Single pedal foot activation of arc start switch and output control, with 25' plug cable.
- K870-1 Start Pedal Foot Amptrol  
Independent start pedal on control pedal provides two-stage foot action to easily feel start switch closure at minimum output level for enhanced arc start and crater-fill control. Provided with adjustable, or removable, heel stop and 25' plug cable. (Refer to Figure B.5)
- K963-3 Hand Amptrol  
Fastens to torch for convenient thumb activation of arc start switch and output control, with 25' plug cable:  
K963-1 is for PTA-9,-17 and PTW-20 Torches.  
K963-2 is for PTA-26 and PTW-18 Torches.
- K814 Arc Start Switch  
Needed for TIG welding without an Amptrol. Includes 25' plug cable, and attaches to torch for convenient finger control.
- K1831-1 Power Factor Capacitor Kit  
Used when welding at higher output currents to reduce input current and help keep electricity costs to a minimum.
- **Magnum® PTA and PTW Series Torches**  
All Air Cooled or Water-Cooled Magnum® TIG Torches may be used with the PRECISION TIG 275. Connection adapters are only required for Air-Cooled Torches (Refer to Diagrams on A-7):  
  
K2166-1 7/8" Torch Connector for PTA-26 (one piece)  
  
K2166-2 1/2" stud Connector for PTA Torch (two-piece).  
  
K2166-3 3/8" TIG Torch Connector for PTA-9,-17 (one piece). (Included as S20403-4 with Precision TIG models.)
- 3100211 Harris Argon Flow Regulator (Includes 10' hose.)
- K2150-1 Work Lead Assembly  
15ft. 2/0 cable with 1/2" stud lug and work clamp.

## OPTIONAL EQUIPMENT

### FACTORY INSTALLED OPTIONS

The basic Precision TIG 275 machine is factory equipped with:

- A 3/8" Adapter (S20403-4) for air cooled torch connection of a PTA-9 or PTA-17.

Accessories that are factory installed with the Domestic model (K1826-1) to make up the Domestic Welding Package (K1825-1) include:

- K1828-1 Under-Cooler Cart
- 3100211 Harris Argon Flow Regulator with 10' Hose.
- K870 Foot Amptrol
- K1784-4 25' PTW-20 water-cooled TIG Torch
- K918-2 Zippered Torch Cover
- KP510 Parts Kit for Torch
- K2150-1 Work Lead Assembly

See below for more detailed descriptions.

### FIELD INSTALLED OPTIONS

The following Options/Accessories are available for the Precision TIG 275 and are installed per instructions in this manual and / or provided in the package:

- K2621-1 Precision TIG Advanced Control Panel Provides 2/4-step trigger with adjustable Pulser controls and Down slope timer for TIG welding. Also includes adjustable Hot Start and Arc Force internal panel controls for Stick welding, and other user selectable features.
- K1828-1 Under-Cooler Cart Includes a "cooler-in-a-drawer" with hoses and a lockable storage drawer on a dual bottle undercarriage (see below).
- K1869-1 Undercarriage Includes a dual bottle rack with chain and an undercarriage with 5" front casters, 10" rear wheels and a handle.
- K1830-1 Water Solenoid Kit Provides for stopping flow of external water supply. Connects to coolant inlet and cooler receptacle of Precision TIG. (Cannot be used with a water cooler.)

- K870 Foot Amptrol Single pedal foot activation of arc start switch and output control, with 25' plug cable.

- K963-3-3 Hand Amptrol Fastens to torch for convenient thumb activation of arc start switch and output control, with 25' plug cable:

- K814 Arc Start Switch Needed for TIG welding without an Amptrol. Includes 25' plug cable, and attaches to torch for convenient finger control.

- K1831-1 Power Factor Capacitor Kit Used when welding at higher output currents to reduce input current and help keep electricity costs to a minimum.

#### • **Magnum® PTA and PTW Series Torches**

All Air Cooled or Water-Cooled Magnum® TIG Torches may be used with the PRECISION TIG 275. Connection adapters are only required for Air-Cooled Torches (Refer to Diagrams on A-7):

K2166-1 7/8" Torch Connector for PTA-26 (one piece)

K2166-2 1/2" stud Connector for PTA Torch (two-piece).

K2166-3 3/8" TIG Torch Connector for PTA-9,-17 (one piece). (Included as S20403-4 with Precision TIG models.)

- 3100211 Harris Argon Flow Regulator (Includes 10' hose.)

- K2150-1 Work Lead Assembly 15ft. 2/0 cable with 1/2" stud lug and work clamp.

PRECISION TIG 275



Return to Section TOC

Return to Section TOC

Return to Section TOC

Return to Section TOC

Return to Master TOC

Return to Master TOC

Return to Master TOC

Return to Master TOC

PRECISION TIG 275



# TABLE OF CONTENTS -MAINTENANCE-

---

<b>Maintenance .....</b>	<b>Section D</b>
Safety Precautions .....	D-2
Routine and Periodic Maintenance .....	D-2
Overload Protection .....	D-2
Fan As Needed (F.A.N.) .....	D-2
Service Procedures.....	D-3
Component Location and Access .....	D-3
Spark Gap Adjustment.....	D-3
Major Component Location.....	D-4

Return to Master TOC

Return to Master TOC

Return to Master TOC

Return to Master TOC

PRECISION TIG 275



## SAFETY PRECAUTIONS

**⚠ WARNING**

**ELECTRIC SHOCK can kill.**

- Only qualified personnel should perform this maintenance.
- Turn the input power **OFF** at the disconnect switch or fuse box before working on this equipment.
- Do not touch electrically hot parts.

**⚠ WARNING**

To avoid receiving a high frequency shock, keep the TIG torch and cables in good condition.

## ROUTINE AND PERIODIC MAINTENANCE

Very little routine maintenance is necessary to keep your Precision TIG 275 running in top condition. No specific schedule can be set for performing the following items; factors such as hours of usage and machine environment should be considered when establishing a maintenance schedule.

- Periodically blow out dust and dirt which may accumulate within the welder using an air stream.
- Inspect welder output and control cables for fraying, cuts, and bare spots.
- Inspect the spark gap at regular intervals to maintain the recommended spacing. See the Service Procedures (See Service Procedures in this Section) for complete information on spark gap settings.
- The fan motor has sealed ball bearings which require no maintenance.

## OVERLOAD PROTECTION

## FAN-AS-NEEDED (F.A.N.)

The Precision TIG 275 has the F.A.N. circuit feature, which means the cooling fan will operate only while welding; then for about 8 minutes after welding has stopped to assure proper machine cooling. This helps reduce the amount of dust and dirt drawn into the machine with the cooling air. The cooling fan will operate briefly when the machine power is initially turned on, and continuously while the yellow Thermal Shutdown Light is lit (see Thermostatic Protection).

## THERMOSTATIC PROTECTION

This welder has thermostatic protection from excessive duty cycles, overloads, loss of cooling, and excessive ambient temperatures. When the welder is subjected to an overload, or inadequate cooling, the primary coil thermostat and/or secondary coil thermostat will open. This condition will be indicated by the illumination of the yellow Thermal Shutdown Light on the front panel (see Item 10 in Section B). The fan will continue to run to cool the power source. Postflow occurs when TIG welding is shut down, but no welding is possible until the machine is allowed to cool and the yellow Thermal Shutdown Light goes out.

## NO ARC PROTECTION

The machine outputs (Background / OCV, gas and HF) will be shutdown, if the trigger is closed without welding for 15 seconds to protect the Background resistor from overheating with F.A.N. cooling off, as well as to conserve on gas waste.

## AUXILIARY POWER CIRCUIT BREAKER

The 115vac auxiliary circuits and rear receptacle (see Section A Auxiliary Power Connections) are protected from overloads by a 15 amp circuit breaker, located above the receptacle. If the breaker trips its button pops out exposing a red ring. When the circuit breaker cools the button can be reset by pressing it back in. Note: When the breaker trips not only will the receptacle's auxiliary and cooler power be interrupted, but so will the power to the shielding gas solenoid and machine cooling fan.

The **Export models** also include a 5 amp circuit breaker, located on the opposite side of the upper case back, for protection of the 220 VAC Schuko type cooler receptacle.

PRECISION TIG 275





## SERVICE PROCEDURES

Operation of the Precision TIG should be trouble-free for the life of the machine. Should a malfunction occur, however, the following procedures will be useful to trained service personnel with experience in repairing arc welding equipment:

### COMPONENT ACCESS

The following components are accessible for routine set up and periodic service without requiring removal of the case sides or roof:

- Input Reconnect Panel (refer Section A) is located behind a removable panel on the rear of the left case side. Remove the two screws (with a screwdriver or a 3/8" / 9.5mm hex driver) on the bottom corners of this panel to remove it.
- Control Box components and PC Boards (refer Section B-6) are located behind the front control panel. Remove the two screws (with a screwdriver or a 3/8" / 9.5mm hex driver) on the top corners of this panel to swing it down.
- Hi-Freq. Spark Gap Assembly (refer Spark Gap Adjustment) is located behind a removable panel on the rear of the right case side, under the torch box. Remove the screw (with a screwdriver or a 3/8" / 9.5mm hex driver) on the bottom center of this panel to remove it.

### SPARK GAP ADJUSTMENT

The spark gap is set at the factory to a gap of 0.015 inches (0.4 mm) See Figure C.1. This setting is adequate for most applications. Where less high frequency is desired, the setting can be reduced to 0.008 inches (0.2 mm).

#### **⚠ WARNING**

Use extreme caution when working with the high frequency circuit. The high voltages developed can be lethal. Turn the input power off using the disconnect switch or fuse box before working inside the machine. This is particularly important when working on the secondary circuit of the high voltage transformer (T3) because the output voltage is dangerously high.

-----

FIGURE C.1 SPARK GAP

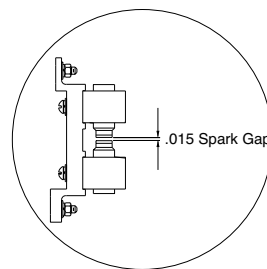

**Note:** In highly dirty environments where there is an abundance of conductive contaminants, use a low pressure air stream or a firm piece of paper to clean out the spark gap. Do not disturb the factory gap setting.

To check the spark gap:

1. Turn the input power off per above.
2. Remove the access panel on the right case side (See Component Access).
3. Check the spark gap spacing with a feeler gauge.

If adjustment is required:

1. Adjust the gap by loosening the Allen head screw on one of the aluminum blocks, reset the gap and tighten the screw in the new position.

If spark gap is correct:

1. Reinstall the access panel on the right case side.

### UNDER-COOLER SERVICE

The required maintenance and service instructions for the Under-Cooler are provided in the operator's manual (IM723) provided with the Under-Cooler Cart.

1. Case Front Assembly
2. Arc Starter and Bypass Assembly
3. Case Back Assembly
4. Center Assembly
5. Case Cover Assembly

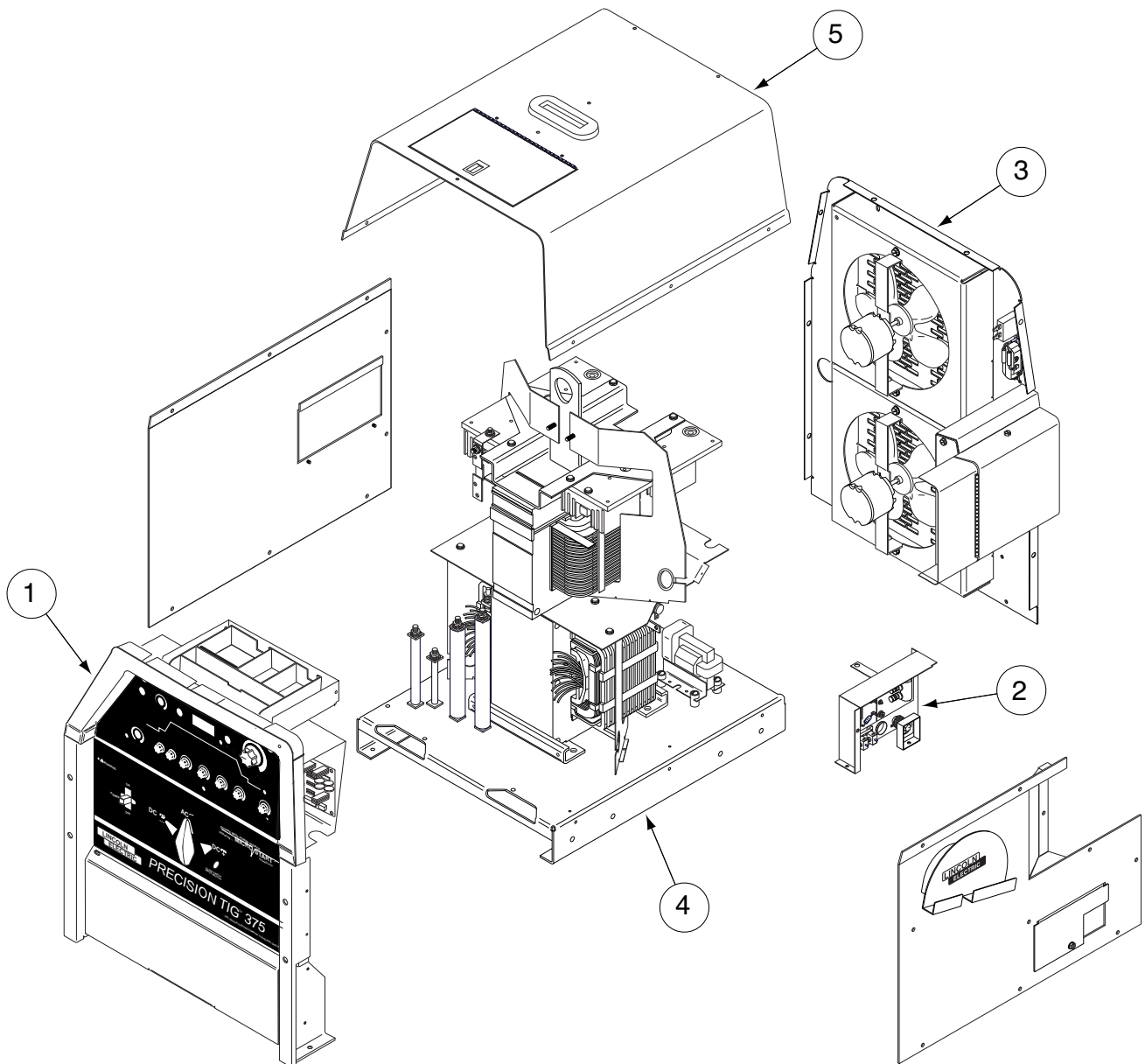

PRECISION TIG 275

**LINCOLN**<sup>®</sup>  
ELECTRIC

# TABLE OF CONTENTS -THEORY OF OPERATION SECTION-

<b>Theory of Operation.....</b>	<b>Section E</b>
General Description .....	E-2
Input Power Circuit.....	E-2
Output Rectification, Control Board and Feedback .....	E-3
High Voltage/High Frequency Circuit .....	E-4
DC Welding Output .....	E-5
AC Welding Output .....	E-6
SCR Operation.....	E-7
Protective Circuits .....	E-8
Fan As Needed (F.A.N.).....	E-8
Thermal Protection .....	E-8
Overload Protection.....	E-8

**FIGURE E.1 – PRECISION TIG 275 BLOCK LOGIC DIAGRAM**

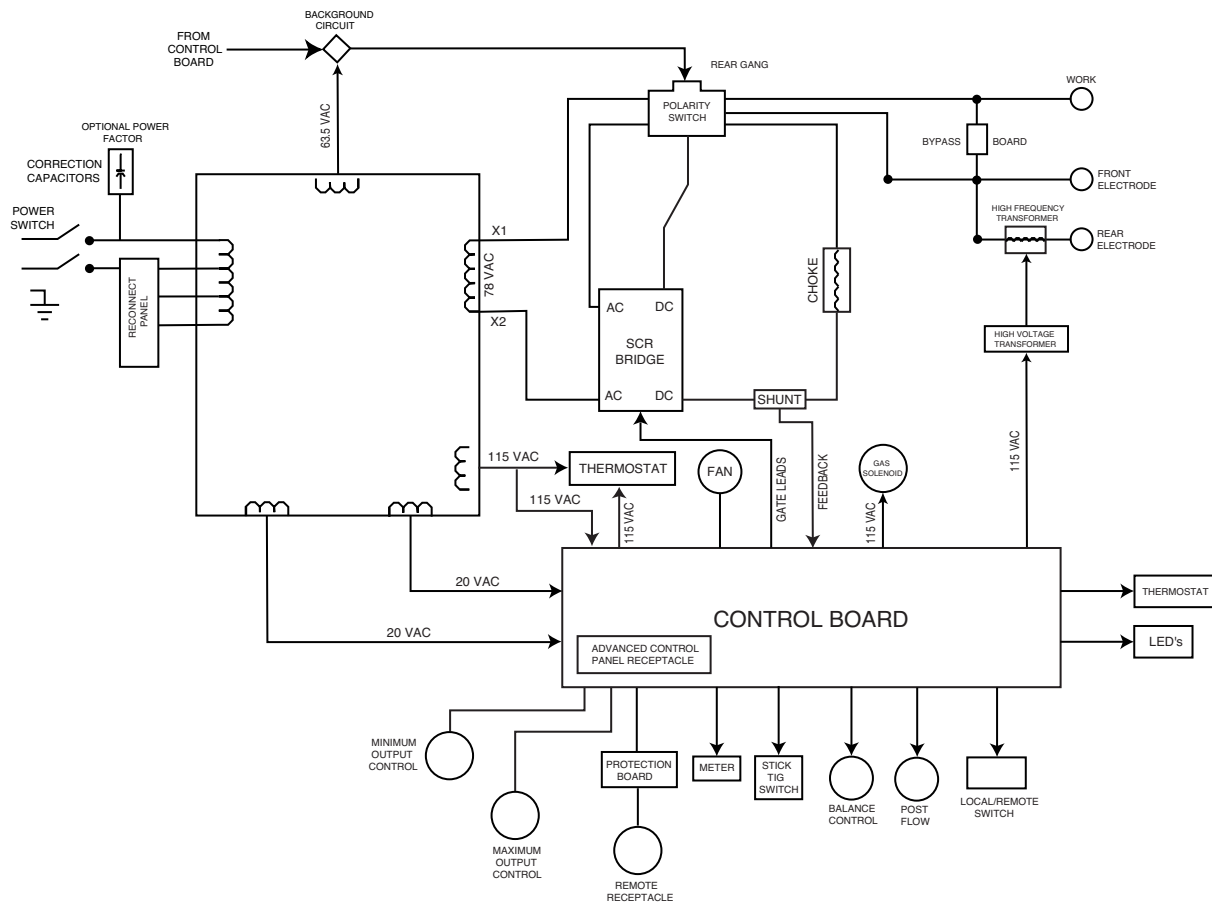

**PRECISION TIG 275**



FIGURE E.2 – GENERAL DESCRIPTION AND INPUT POWER CIRCUIT

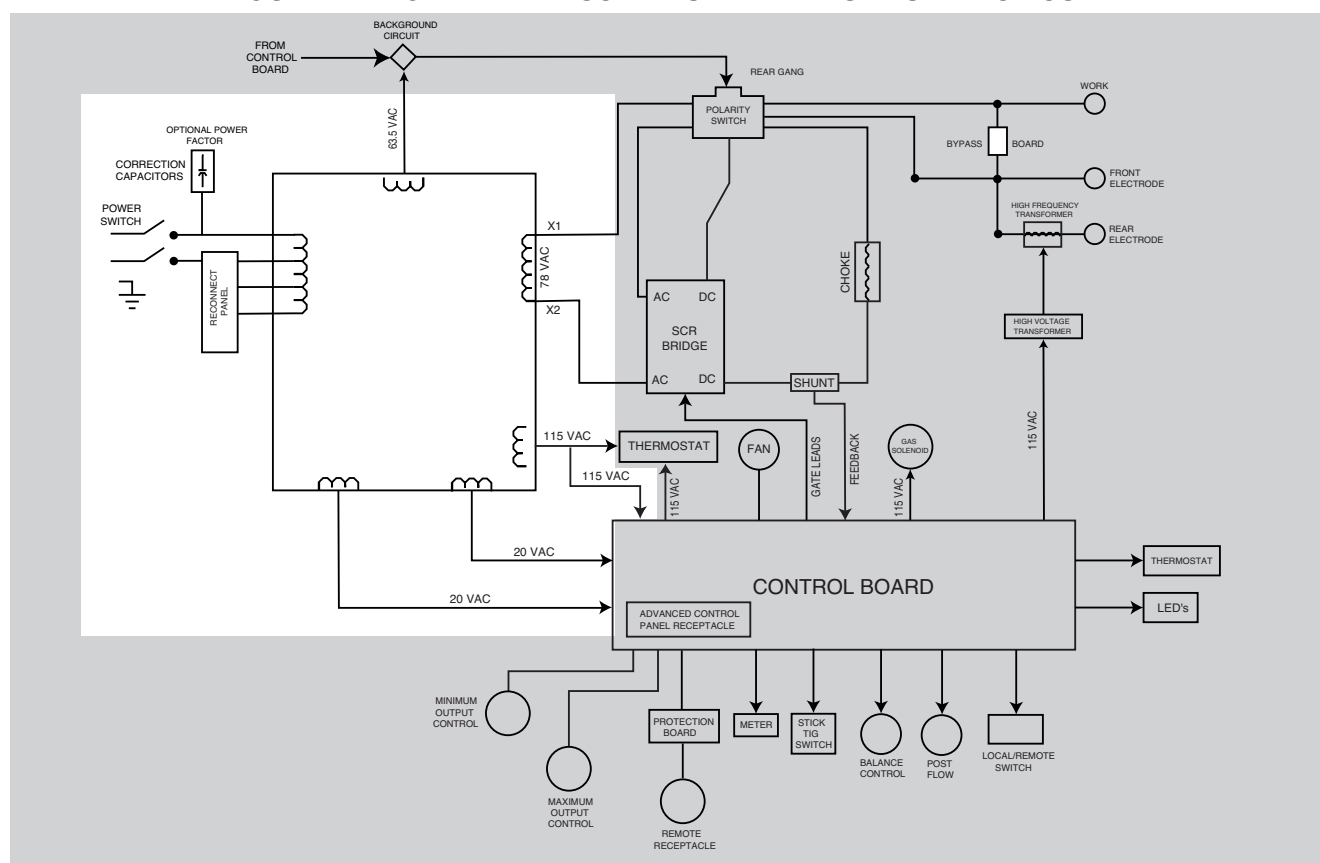

## GENERAL DESCRIPTION

The PRECISION TIG 275 is part of a new family of industrial arc welding power sources able to provide constant current and single range square wave AC/DC Tig (GTAW) with new MicroStart™ Technology. It incorporates independent presettable minimum and maximum output control with built-in high frequency stabilization for continuous AC Tig welding and reliable DC Tig starting. The Precision TIG 275 also has AC/DC stick (SMAW) capabilities. This new design includes advanced features such as a digital meter, presettable controls, auto balance™, fan as needed and timers for fixed preflow and variable post flow of shielding gas. It features a stick output terminal (front) and a universal Tig torch connection box (rear) for simultaneous, but separate, electrode outputs.

## INPUT POWER CIRCUIT

The desired single-phase input power is connected to the PRECISION TIG 275 through the power switch to the reconnect panel located in the rear of the machine. The machine can be configured for any one of three input voltages (208 VAC, 230 VAC or 460 VAC) by connecting the jumper strap to the appropriate terminal on

the reconnect panel. When the input power switch is turned “on,” the input voltage is applied directly to the primary winding of the main transformer.

The main transformer changes the high voltage, low current input power to a low voltage, high current output available at the main secondary winding (X1 and X2). This 78 VAC winding supplies power to the welding arc. In addition, four auxiliary windings are incorporated in the main transformer. The 115 VAC winding supplies power to the 115 VAC receptacle. Through the control board, it also powers the gas solenoid, the high voltage transformer, and the cooling fan. The cooling fan is activated only when welding current is sensed. The 63.5 VAC winding provides power for the DC background current. This circuit is active in the DC TIG welding mode. The 20 VAC windings are included in the main transformer assembly. The 20 VAC winding is rectified on the control board and is used in the trigger circuitry. The other 20 VAC winding is used by the control board for phase detection. This AC voltage is also rectified to several DC voltages and regulated to +15 VDC and +5 VDC power supplies that operate the circuitry on the control board.

**NOTE:** Unshaded areas of Block Logic Diagram are the subject of discussion.

## PRECISION TIG 275



FIGURE E.3 – OUTPUT RECTIFICATION, CONTROL BOARD AND FEEDBACK

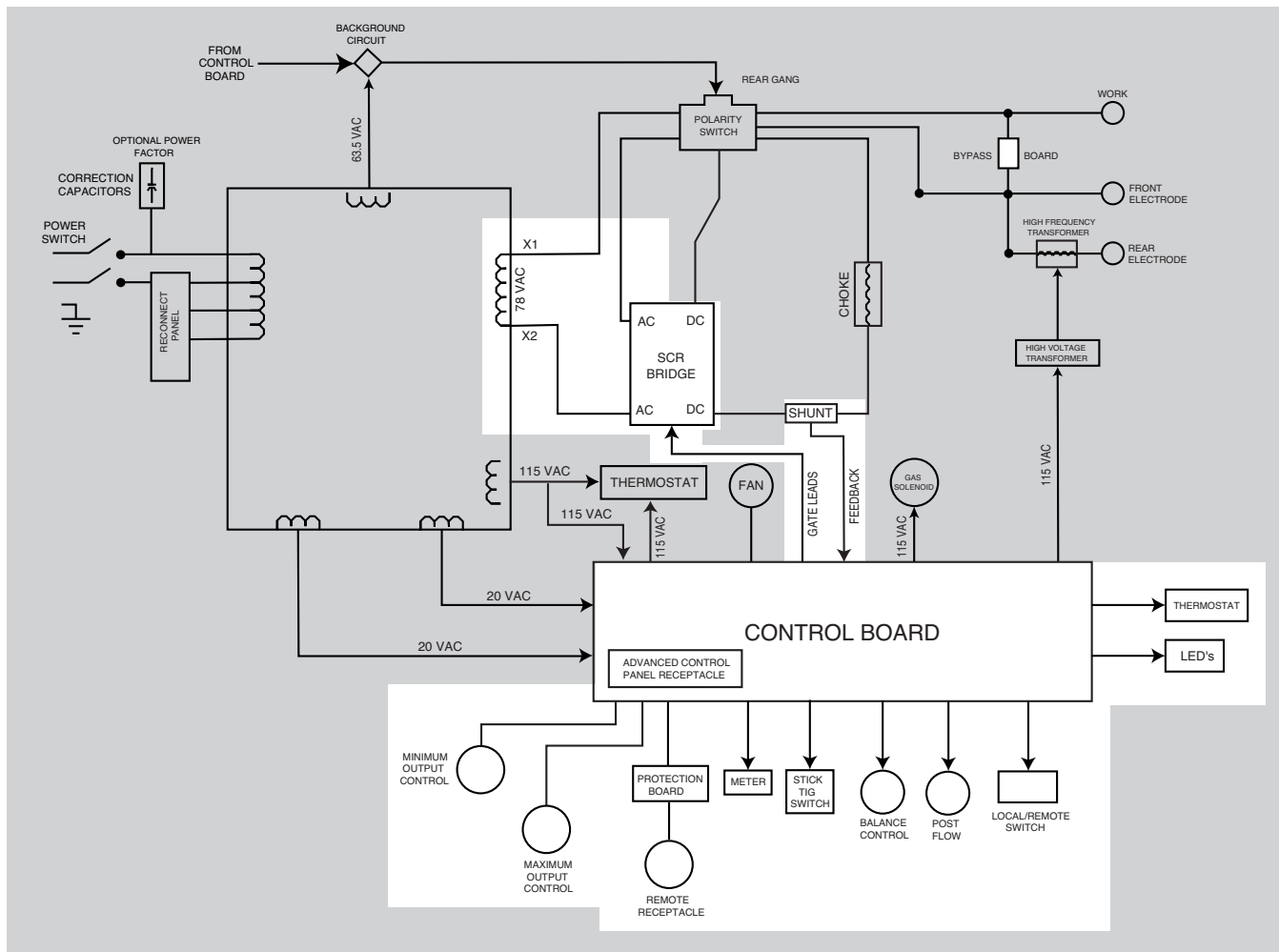

## OUTPUT RECTIFICATION, CONTROL BOARD AND FEEDBACK

The AC output from the main transformer secondary is rectified and controlled through the SCR bridge. Output current is sensed at the shunt as a low voltage signal and fed back to the control board. The control board senses the status and settings of the various operator controls such as the Stick/TIG switch, the output controls, the remote control receptacle, the local/remote switch, the balance control and the post-flow control. Circuitry on the control board evaluates these commands, compares them to the feedback information received from the shunt and sends the appropriate gate firing signals to the output SCR bridge. The control board regulates the firing of the output SCRs, which control the output of the machine. See **SCR Operation**.

The control board also monitors the thermostats and controls the gas solenoid, the thermal light, the high voltage transformer and the cooling fan. The optional advanced control panel also plugs into and interfaces with the control board.

PRECISION TIG 275







FIGURE E.5 – DC WELDING OUTPUT

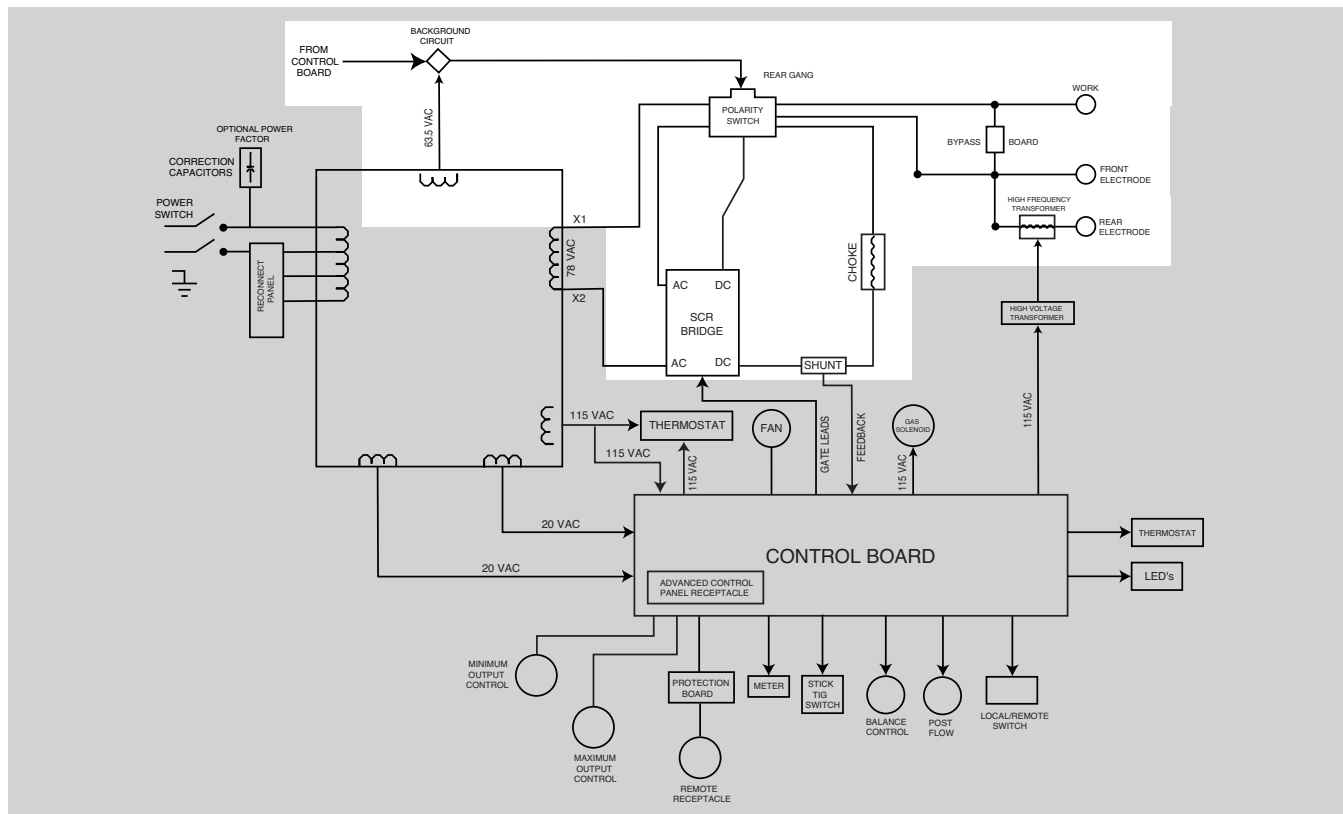

### DC WELDING OUTPUT

When the polarity switch is placed in either DC position, the AC voltage from the main transformer secondary is applied to the SCR bridge. The SCR bridge and choke circuits are connected in the conventional full wave bridge and filter configuration, resulting in a controlled DC output. Since the choke is in series with the negative leg of the bridge and also in series with the welding load, a filtered DC is applied to the output terminals. The bypass board protects the internal circuitry from interference.

When the machine is in the DC mode, the background circuitry provides an added boost of voltage to the output terminals. This circuitry is controlled by the control board.

FIGURE E.6 DC WELDING CURRENT GENERATION

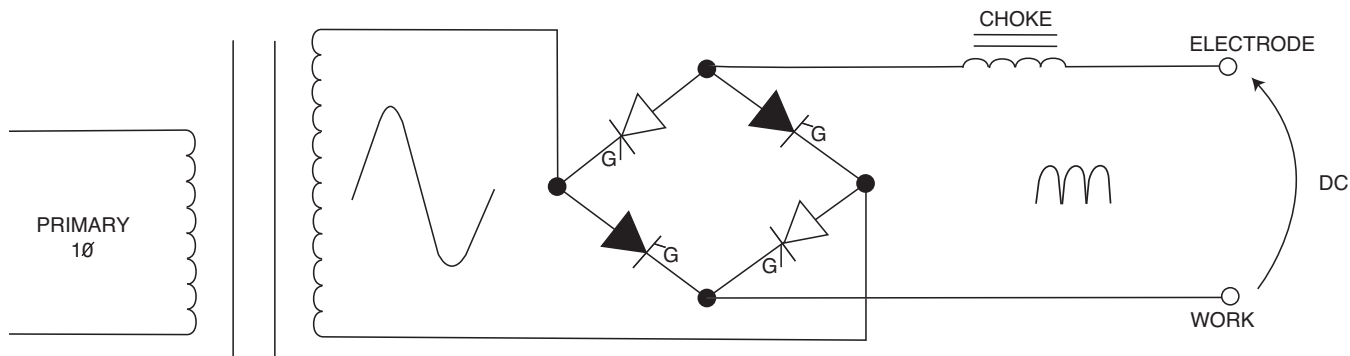

PRECISION TIG 275



Return to Section TOC

Return to Section TOC

Return to Section TOC

Return to Section TOC

Return to Master TOC

Return to Master TOC

Return to Master TOC

Return to Master TOC

FIGURE E.7 – AC WELDING OUTPUT

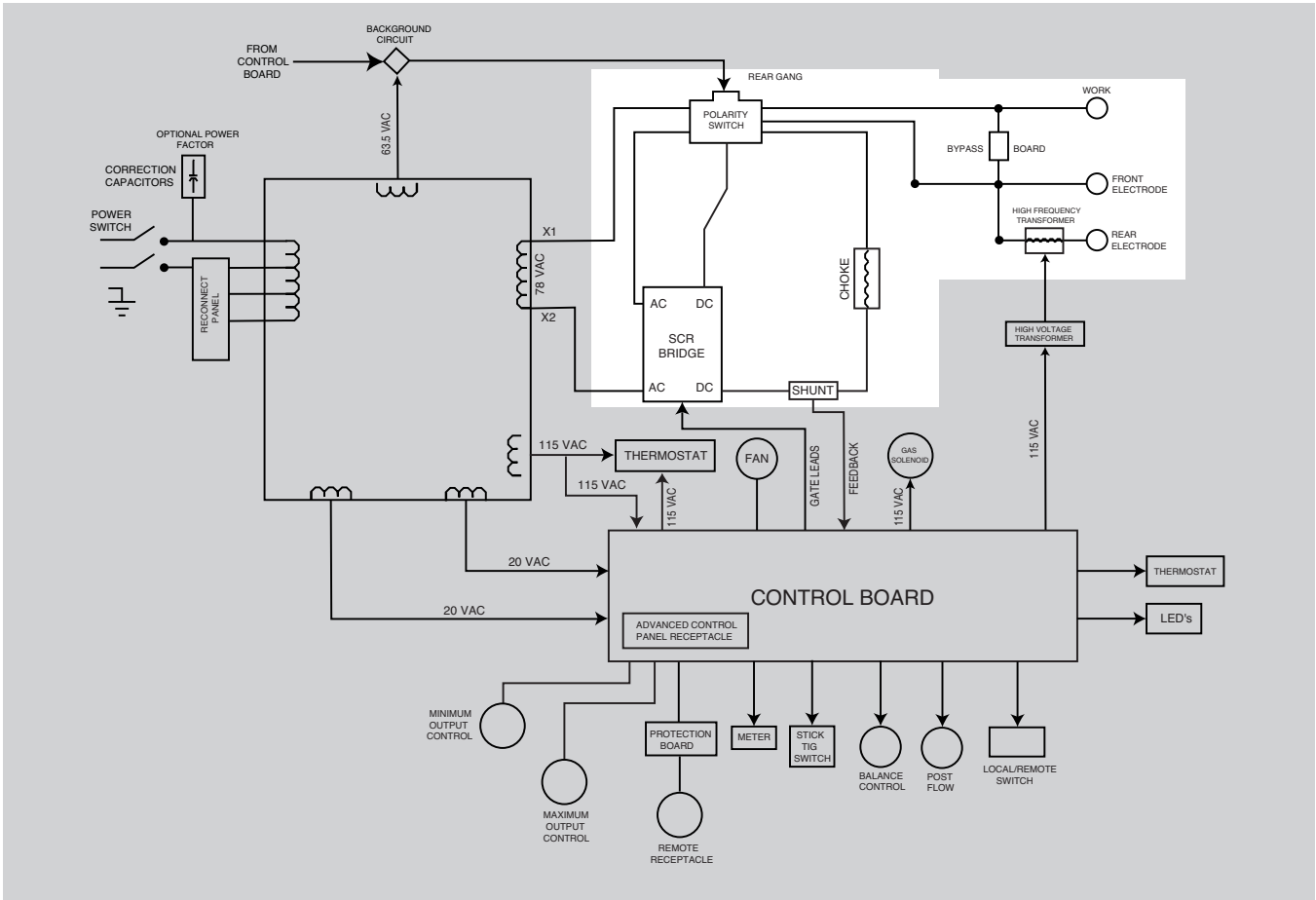

### AC WELDING OUTPUT

Rotating the polarity switch to the AC position changes the welding power circuit. One lead (X1) of the main transformer secondary is connected to the machine's output work terminal. The other secondary lead (X2) is connected to one of the AC connections of the SCR bridge. The electrode terminal is connected to the other AC side of the bridge. The choke is now

electrically across the negative and positive SCR bridge connections. With the ability of the choke to store energy and the SCRs to turn on at the appropriate times, an AC square wave is developed and applied to the output terminals. The bypass board protects the internal circuitry from interference.

FIGURE E.8 DC WELDING CURRENT GENERATION

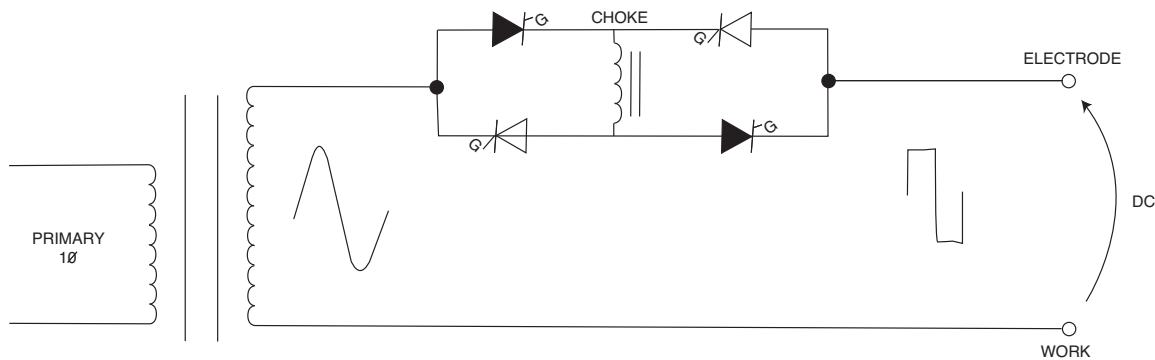

PRECISION TIG 275



[Return to Section TOC](#) | [Return to Section TOC](#) | [Return to Section TOC](#) | [Return to Master TOC](#) | [Return to Master TOC](#) | [Return to Master TOC](#)

FIGURE E.9 – SCR OPERATION

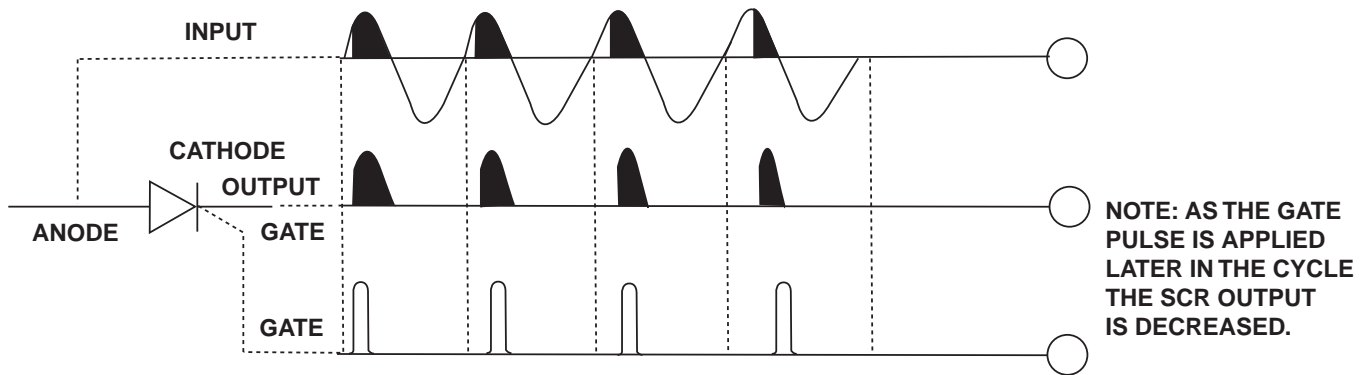

## SCR OPERATION

A silicon controlled rectifier (SCR) is a three-terminal device used to control rather large currents to a load. An SCR acts very much like a switch. When a gate signal is applied to the SCR, it is turned ON and there is current flow from anode to cathode. In the ON state the SCR acts like a closed switch. When the SCR is turned OFF there is no current flow from anode to cathode. Thus, the device acts like an open switch. As the name suggests, the SCR is a rectifier, so it passes current only during positive half cycles of the AC supply. The positive half cycle is the portion of the sine wave in which the anode of the SCR is more positive than the cathode.

When an AC supply voltage is applied to the SCR, the device spends a certain portion of the AC cycle time in the ON state and the remainder of the time in the OFF state. The amount of time spent in the ON state is controlled by the gate.

An SCR is fired by a short burst of current into the gate. This gate pulse must be more positive than the cathode voltage. Since there is a standard PN junction between gate and cathode, the voltage between these terminals must be slightly greater than 0.6V. Once the SCR has fired, it is not necessary to continue the flow of gate current. As long as current continues to flow from anode to cathode, the SCR will remain on. When the anode to cathode current drops below a minimum value, called holding current, the SCR will shut off. This normally occurs as the AC supply voltage passes through zero into the negative portion of the sine wave. If the SCR is turned on early in the positive half cycle the conduction time is longer, resulting in greater SCR output. If the gate firing occurs later in the cycle the conduction time is less, resulting in lower SCR output.

PRECISION TIG 275

**LINCOLN**<sup>®</sup>  
ELECTRIC

## PROTECTION CIRCUITS

Protection circuits are designed into the PRECISION Tig 275 machine to sense trouble and shut down the machine before the trouble damages internal machine components. Both thermal protection and current overload are included.

### FAN-AS-NEEDED (F.A.N.)

The PRECISION Tig 275 has the F.A.N. circuit feature, which means that the cooling fan will operate only while welding; then for about eight minutes after welding has stopped to assure proper machine cooling. This helps reduce the amount of dirt and dust drawn into the machine along with the cooling air. The cooling fan will operate briefly when the machine power is initially turned on, and continuously while the yellow Thermal shutdown light is lit.

### THERMAL PROTECTION

This welder has thermostatic protection from excessive duty cycles, overloads, loss of cooling and excessive ambient temperatures. When the welder is subjected to an overload, or inadequate cooling, the primary coil thermostat and/or secondary coil thermostat will open. This condition will be indicated by the illumination of the yellow Thermal Shutdown light on the front panel. The fan will continue to run to cool the power source. Postflow occurs when Tig welding is shut down, but no welding is possible until the machine is allowed to cool and the yellow Thermal Shutdown light goes out. Once the machine cools sufficiently, the thermostats are self-resetting. If the shutdown is caused by excessive output or duty cycle and the fan is operating normally, the power may be left on and the reset should occur within a 15 minute period. If the fan is not functioning properly or the air intake louvers are obstructed, the input power must be removed and the fan problem or air obstruction corrected.

### OVERLOAD PROTECTION

The machine is electronically protected from producing excessively high output currents. The output is limited to 350 amps.

PRECISION TIG 275



# TABLE OF CONTENTS

## TROUBLESHOOTING & REPAIR SECTION

Return to Master TOC

Return to Master TOC

Return to Master TOC

Return to Master TOC

<b>Troubleshooting &amp; Repair Section .....</b>	<b>Section F</b>
How to Use Troubleshooting Guide .....	F-2
PC Board Troubleshooting Procedures and Replacement.....	F-3
Troubleshooting Guide.....	F-4
Test Procedures	
Meter Calibration Adjustments .....	F-19
High Frequency Circuit Disable Procedure .....	F-23
Protection Board Test .....	F-25
T1 Main Transformer Test .....	F-27
Gas (Water) Solenoid Test .....	F-31
Static SCR Test .....	F-33
Active SCR Test.....	F-35
Typical Output Voltage Waveform (DC Tig Mode) .....	F-39
Typical Output Voltage Waveform (AC Tig Mode).....	F-40
Typical AC Voltage Waveform - 50 AMPS (AC Tig Mode) .....	F-41
Typical AC Voltage Waveform - 2 AMPS (AC Tig Mode) .....	F-42
Typical Output Voltage Waveform - 200 AMPS ( DC Tig Mode).....	F-43
Replacement Procedures	
High Voltage Transformer Removal & Replacement.....	F-45
Control Board Removal and Replacement.....	F-49
SCR Bridge Assembly Removal and Replacement .....	F-53
Polarity Switch Removal and Replacement .....	F-57
SCR Removal and Replacement .....	F-59
Retest after Repair .....	F-61



## HOW TO USE TROUBLESHOOTING GUIDE

**⚠ WARNING**

Service and repair should be performed by only Lincoln Electric Factory Trained Personnel. Unauthorized repairs performed on this equipment may result in danger to the technician and machine operator and will invalidate your factory warranty. For your safety and to avoid Electrical Shock, please observe all safety notes and precautions detailed throughout this manual.

This Troubleshooting Guide is provided to help you locate and repair possible machine malfunctions. Simply follow the three-step procedure listed below.

**Step 1. LOCATE PROBLEM (SYMPTOM).** Look under the column labeled “PROBLEM” (SYMPTOMS). This column describes possible symptoms that the machine may exhibit. Find the listing that best describes the symptom that the machine is exhibiting. Symptoms are grouped into four main categories: Output Problems, Function Problems, Cutting Problems and LED Function Problems.

**Step 2. PERFORM EXTERNAL TESTS.** The second column, labeled “POSSIBLE AREAS OF MISADJUSTMENT(S)”, lists the obvious external possibilities that may contribute to the machine symptom. Perform these tests/checks in the order listed. In general, these tests can be conducted without removing the case wrap-around cover.

**Step 3. RECOMMENDED COURSE OF ACTION**

The last column, labeled “Recommended Course of Action” lists the most likely components that may have failed in your machine. It also specifies the appropriate test procedure to verify that the subject component is either good or bad. If there are a number of possible components, check the components in the order listed to eliminate one possibility at a time until you locate the cause of your problem.

All of the referenced test procedures referred to in the Troubleshooting Guide are described in detail at the end of this chapter. Refer to the Troubleshooting and Repair Table of Contents to locate each specific Test Procedure. All of the referred to test points, components, terminal strips, etc., can be found on the referenced electrical Wiring Diagrams and Schematics. Refer to the Electrical Diagrams Section Table of Contents to locate the appropriate diagram.

**⚠ CAUTION**

If for any reason you do not understand the test procedures or are unable to perform the test/repairs safely, contact the Lincoln Electric Service Department for electrical troubleshooting assistance before you proceed. Call 1-888-935-3877.

**⚠ WARNING**

**HIGH VOLTAGE/ HIGH FREQUENCY can damage test equipment.**

\* Perform all voltage and wave form checks with high frequency circuit OFF.

Perform **High Frequency Disable Procedure.**

PRECISION TIG 275





PC BOARD TROUBLESHOOTING PROCEDURES

**WARNING**



**ELECTRIC SHOCK can kill.**

\*Have an electrician install and service this equipment. Turn the machine OFF before working on equipment. **Do not touch electrically hot parts.**

Sometimes machine failures appear to be due to PC Board failures. These problems can sometimes be traced to poor electrical connections. To avoid problems when troubleshooting and replacing PC Boards, please use the following procedure:

1. Determine to the best of your technical ability that the PC Board is the most likely component causing the failure symptom.
2. Check for loose connections at the PC Board to assure that the PC Board is properly connected.
3. If the problem persists, replace the suspect PC Board using standard practices to avoid static electrical damage and electrical shock. Read the warning inside the static resistant bag and perform the following procedures:



**PC Board can be damaged by static electricity.**

- Remove your body's static charge before opening the static-shielding bag. Wear an anti-static wrist strap. For safety, use a 1 Meg ohm resistive cord connected to a grounded part of the equipment frame.
- If you don't have a wrist strap, touch an unpainted, grounded, part of the equipment frame. Keep touching the frame to prevent static build-up. Be sure not to touch any electrically live parts at the same time.

- Tools which come in contact with the PC Board must be either conductive, anti-static or static-disipative.

- Remove the PC Board from the static-shielding bag and place it directly into the equipment. Don't set the PC Board on or near paper, plastic or cloth which could have a static charge. If the PC Board can't be installed immediately, put it back in the static-shielding bag.
- If the PC Board uses protective shorting jumpers, don't remove them until installation is complete.
- If you return a PC Board to The Lincoln Electric Company for credit, it must be in the static-shielding bag. This will prevent further damage and allow proper failure analysis.

4. Test the machine to determine if the failure symptom has been corrected by the replacement PC Board.

**NOTE:** It is desirable to have a spare (known good) PC Board available for PC Board troubleshooting.

**NOTE:** Allow the machine to heat up so that all electrical components can reach their operating temperature.

5. Remove the replacement PC Board and substitute it with the original PC Board to recreate the original problem.
  - a. If the original problem does not reappear by substituting the original board, then the PC Board was not the problem. Continue to look for bad connections in the control wiring harness, junction blocks, and terminal strips.
  - b. If the original problem is recreated by the substitution of the original board, then the PC Board was the problem. Reinstall the replacement PC Board and test the machine.
6. Always indicate that this procedure was followed when warranty reports are to be submitted.

**NOTE:** Following this procedure and writing on the warranty report, "INSTALLED AND SWITCHED PC BOARDS TO VERIFY PROBLEM," will help avoid denial of legitimate PC Board warranty claims.

Observe Safety Guidelines detailed in the beginning of this manual.

## TROUBLESHOOTING GUIDE

PROBLEMS (SYMPTOMS)	POSSIBLE AREAS OF MISADJUSTMENT(S)	RECOMMENDED COURSE OF ACTION
<b>OUTPUT PROBLEMS</b>		
<p>The machine is dead. No weld output – no 115 VAC at the receptacle.</p>	<ol style="list-style-type: none"> <li>1. Check the input voltage. The input voltage must match the rating plate and the voltage connection. Refer to <b>Reconnect Procedure</b> in the Installation section of this manual.</li> <li>2. Make sure that the input power switch is in the “ON” position.</li> <li>3. Check for blown or missing fuses in the input lines.</li> <li>4. Check circuit breaker CB1. Reset if necessary.</li> </ol>	<ol style="list-style-type: none"> <li>1. Check the input power switch, reconnect panel and associated wires for loose or faulty connections.</li> <li>2. The input power switch may be faulty.</li> <li>3. Perform the <b>T1 Transformer Test</b>.</li> </ol>

### CAUTION

If for any reason you do not understand the test procedures or are unable to perform the test/repairs safely, contact the Lincoln Electric Service Department for electrical troubleshooting assistance before you proceed. Call 1-888-935-3877.

PRECISION TIG 275



**TROUBLESHOOTING GUIDE**

Observe Safety Guidelines detailed in the beginning of this manual.

PROBLEMS (SYMPTOMS)	POSSIBLE AREAS OF MISADJUSTMENT(S)	RECOMMENDED COURSE OF ACTION
<b>OUTPUT PROBLEMS</b>		
<p>No welding output. The 115 VAC is present at the receptacle.</p> <p><b>NOTE: BEFORE REPLACING A CONTROL BOARD</b></p> <p>If an Advanced Control Panel is installed, remove it and replace the Jumper in connector J-3. If the machine functions normally, the Advanced Process panel or harness is defective.</p>	<ol style="list-style-type: none"> <li>1. Make sure the polarity switch is in the proper position and functioning correctly.</li> <li>2. One of the thermostats may be tripped. Allow the machine to cool. The thermal light will be on.</li> <li>3. Make sure the welding cables, torch and connections are in good operating condition.</li> </ol>	<ol style="list-style-type: none"> <li>1. Check for loose or faulty connections on the heavy current carrying leads. (Polarity switch, output choke, output terminals, etc.)</li> <li>2. Check for faulty connections or a defective thermostat. Check leads #213 and #214. See the Wiring Diagram. The thermal light will be on.</li> <li>3. Perform the <b>T1 Transformer Test</b>.</li> <li>4. Perform the <b>SCR Bridge Test</b>.</li> <li>5. Check the output controls R1, R4 and associated wiring. See Wiring Diagram.</li> <li>6. Check the J4 connection on the control board.</li> <li>7. The control board may be faulty.</li> </ol>

**⚠ CAUTION**

If for any reason you do not understand the test procedures or are unable to perform the test/repairs safely, contact the Lincoln Electric Service Department for electrical troubleshooting assistance before you proceed. Call 1-888-935-3877.

PRECISION TIG 275



Return to Section TOC

Return to Section TOC

Return to Section TOC

Return to Section TOC

Return to Master TOC

Return to Master TOC

Return to Master TOC

Return to Master TOC

Observe Safety Guidelines detailed in the beginning of this manual.

TROUBLESHOOTING GUIDE

PROBLEMS (SYMPTOMS)	POSSIBLE AREAS OF MISADJUSTMENT(S)	RECOMMENDED COURSE OF ACTION
<b>OUTPUT PROBLEMS</b>		
<p>No output from the machine in either Stick or TIG modes. The thermal light is on.</p> <p><b>NOTE: BEFORE REPLACING A CONTROL BOARD</b></p> <p><b>If an Advanced Control Panel is installed, remove it and replace the Jumper in connector J-3. If the machine functions normally, the Advanced Process panel or harness is defective.</b></p>	<ol style="list-style-type: none"> <li>1. The welding application may have exceeded the recommended duty cycle. Allow the fan to cool the until the thermal light is off.</li> <li>2. The air louvers may be blocked. Remove the air obstruction and allow the unit to cool.</li> </ol>	<ol style="list-style-type: none"> <li>1. One of the thermostats may be faulty. Check or replace. See the Wiring Diagram.</li> <li>2. Check for loose or faulty wires on the thermostats and associated circuitry. See the Wiring Diagram.</li> <li>3. The fan motor may be faulty or mechanically obstructed. The fan should run when welding or when a thermostat is open.</li> <li>4. The control board may be faulty.</li> </ol>
<p>The machine does not respond (no gas flow, no high frequency and no open circuit voltage) when the arc start switch or Amptrol is activated. The thermal light is not lit.</p> <p><b>NOTE: BEFORE REPLACING A CONTROL BOARD</b></p> <p><b>If an Advanced Control Panel is installed, remove it and replace the Jumper in connector J-3. If the machine functions normally, the Advanced Process panel or harness is defective.</b></p>	<ol style="list-style-type: none"> <li>1. Make sure the machine is in the TIG mode.</li> <li>2. The Amptrol or arc start switch may be defective. Check for continuity ( zero ohms) between pins "D" and "E" on the cable connector when the Amptrol or arc start is pressed.</li> <li>3. Check the Local/Remote switch for proper operation.</li> </ol>	<ol style="list-style-type: none"> <li>1. Perform the <b>Protection Board Test</b>.</li> <li>2. Perform the <b>T1 Transformer Test</b>.</li> <li>3. The control board may be faulty.</li> </ol>

**⚠ CAUTION**

If for any reason you do not understand the test procedures or are unable to perform the test/repairs safely, contact the Lincoln Electric Service Department for electrical troubleshooting assistance before you proceed. Call 1-888-935-3877.

PRECISION TIG 275



Return to Section TOC  
Return to Master TOC







# TROUBLESHOOTING & REPAIR

## TROUBLESHOOTING GUIDE

Observe Safety Guidelines detailed in the beginning of this manual.

PROBLEMS (SYMPTOMS)	POSSIBLE AREAS OF MISADJUSTMENT(S)	RECOMMENDED COURSE OF ACTION
<b>OUTPUT PROBLEMS</b>		
<p>The machine makes a very loud buzzing noise in DC Stick or in DC TIG modes. There is no current draw from the machine's output terminals. (The machine is not externally loaded).</p>	<p>1. Inspect the output terminal insulators for cracks or signs of overheating.</p>	<p>1. Diode D1 may be shorted. Check and replace if necessary.</p> <p>2. Check the polarity switch (S2) for proper function and correct connections.</p> <p>3. Perform the <b>SCR Bridge Tests</b>.</p>

**⚠ CAUTION**

If for any reason you do not understand the test procedures or are unable to perform the test/repairs safely, contact the Lincoln Electric Service Department for electrical troubleshooting assistance before you proceed. Call 1-888-935-3877.

**PRECISION TIG 275**



Return to Section TOC

Return to Master TOC

# TROUBLESHOOTING & REPAIR

## TROUBLESHOOTING GUIDE

Observe Safety Guidelines detailed in the beginning of this manual.

PROBLEMS (SYMPTOMS)	POSSIBLE AREAS OF MISADJUSTMENT(S)	RECOMMENDED COURSE OF ACTION
TIG WELDING PROBLEMS		
<p>The machine output is intermittently lost. Gas flow and high frequency are also interrupted.</p> <p><b>NOTE: BEFORE REPLACING A CONTROL BOARD</b></p> <p><b>If an Advanced Control Panel is installed, remove it and replace the Jumper in connector J-3. If the machine functions normally, the Advanced Process panel or harness is defective.</b></p>	<ol style="list-style-type: none"> <li>1. The problem may be caused by high frequency interference. Make sure that the machine is grounded properly according to the installation instructions. If there are other high frequency sources in the area, make certain that they are grounded properly.</li> <li>2. Make sure the Amptrol is operating properly.</li> <li>3. Check to make sure that the input voltage is correct for the machine. Refer to <b>Reconnect Procedure</b> in the Installation section of this manual.</li> </ol>	<ol style="list-style-type: none"> <li>1. Check for loose or faulty connections on the leads between the remote receptacle, the protection board and plug J22 on the protection board. See the Wiring Diagram.</li> <li>2. Check plugs J5 and J23 on the protection board for loose or faulty connections.</li> <li>3. Perform the <b>Protection Board Test</b>.</li> <li>4. The control board may be faulty.</li> <li>5. Check the ground connection of the bypass/ stabilizer P.C. Board. See the Wiring Diagram.</li> </ol>
<p>No gas or water flow (with optional water solenoid) when the arc start switch or Amptrol is activated in the TIG mode. All other machine functions are normal.</p>	<ol style="list-style-type: none"> <li>1. The gas (or water) supply is either empty or not turned on.</li> <li>2. The low regulator may be set too low.</li> <li>3. Check the supply hoses for kinks or blockages.</li> <li>4. The filters may be blocked.</li> </ol>	<ol style="list-style-type: none"> <li>1. Perform the <b>Gas Solenoid Test</b>.</li> <li>2. The control board may be faulty.</li> </ol>

**⚠ CAUTION**

If for any reason you do not understand the test procedures or are unable to perform the test/repairs safely, contact the Lincoln Electric Service Department for electrical troubleshooting assistance before you proceed. Call 1-888-935-3877.

PRECISION TIG 275





Return to Section TOC  
Return to Master TOC

# TROUBLESHOOTING & REPAIR

## TROUBLESHOOTING GUIDE

Observe Safety Guidelines detailed in the beginning of this manual.

PROBLEMS (SYMPTOMS)	POSSIBLE AREAS OF MISADJUSTMENT(S)	RECOMMENDED COURSE OF ACTION
<b>TIG WELDING PROBLEMS</b>		
<p>No high frequency. The machine is in the TIG mode and has normal output.</p> <p><b>NOTE: BEFORE REPLACING A CONTROL BOARD</b></p> <p>If an Advanced Control Panel is installed, remove it and replace the Jumper in connector J-3. If the machine functions normally, the Advanced Process panel or harness is defective.</p>	<ol style="list-style-type: none"> <li>1. If the machine is in a dirty environment with conductive contaminants, check and clean the spark gap with a low pressure air stream per the maintenance instructions.</li> <li>2. Check the spark gap operations and setting. Normal is (0.015"). Refer to the <i>Maintenance Section</i> of this manual.</li> <li>3. Check circuit breaker CB1. Reset if necessary.</li> <li>4. Check connection J12 on the control board.</li> </ol>	<ol style="list-style-type: none"> <li>1. Check the high voltage transformer (T2). The normal resistance of the secondary winding is 12.5k ohms.</li> </ol> <div style="text-align: center; background-color: black; color: white; padding: 5px; margin: 10px 0;">  <b>WARNING</b> </div> <div style="display: flex; align-items: center;">  <div> <p><b>ELECTRIC SHOCK CAN KILL.</b> When 115 VAC is applied to T2, a very high voltage is developed on the secondary winding. For assistance, call the Lincoln Electric Service Department. 1-888-935-3877.</p> </div> </div> <ol style="list-style-type: none"> <li>2. Check R5, C6, C7, L2 and L3. Replace if defective.</li> <li>3. The control board may be faulty.</li> </ol>
<p>The High frequency is on continuously in DC TIG or shuts off in AC TIG.</p>	<ol style="list-style-type: none"> <li>1. None</li> </ol>	<ol style="list-style-type: none"> <li>1. Check plug J11 on the control board. See the Wiring Diagram.</li> <li>2. Check micro-switch S2A for proper operation. See the Wiring Diagram.</li> <li>3. The control board may be faulty.</li> </ol>

 **CAUTION**

If for any reason you do not understand the test procedures or are unable to perform the test/repairs safely, contact the Lincoln Electric Service Department for electrical troubleshooting assistance before you proceed. Call 1-888-935-3877.

PRECISION TIG 275



Return to Section TOC    Return to Section TOC    Return to Section TOC    Return to Section TOC

Return to Master TOC    Return to Master TOC    Return to Master TOC    Return to Master TOC



# TROUBLESHOOTING & REPAIR

## TROUBLESHOOTING GUIDE

Observe Safety Guidelines detailed in the beginning of this manual.

PROBLEMS (SYMPTOMS)	POSSIBLE AREAS OF MISADJUSTMENT(S)	RECOMMENDED COURSE OF ACTION
<b>TIG WELDING PROBLEMS</b>		
The high frequency “spark” is present at the tungsten electrode, but the operator is unable to establish a welding arc. The machine has a normal open circuit voltage. Refer to <b>Technical Specifications</b> in the Installation section.	<ol style="list-style-type: none"> <li>1. The torch may be faulty. Check or replace.</li> <li>2. The current control may be set too low.</li> <li>3. The tungsten electrode may be contaminated. Replace or sharpen.</li> <li>4. The electrode may be too large for the process.</li> <li>5. If a helium blend is being used as a shielding gas, reduce the percentage of helium.</li> <li>6. Check the welding cables for loose or faulty connections.</li> </ol>	<ol style="list-style-type: none"> <li>1. Check spark gap adjustment. See the <b>Maintenance Section</b>.</li> <li>2. This may be a welding procedure problem. Contact the Lincoln Service Department, Technical Sales group at 1-888-935-3877.</li> </ol>
When AC TIG welding, the arc is erratic and there is a loss of “cleaning” of the work piece.	<ol style="list-style-type: none"> <li>1. The tungsten electrode may be small for the process. Use a larger diameter tungsten or a pure tungsten.</li> <li>2. If a helium blend is used as a shielding gas, reduce the percentage of helium.</li> <li>3. Check the balance control setting.</li> </ol>	<ol style="list-style-type: none"> <li>1. Check components R5 and C7 in the high voltage transformer primary circuit.</li> <li>2. Perform the <b>SCR Bridge Test</b>.</li> </ol>
Arc “pulsates” in AC polarity. DC TIG is OK.	<ol style="list-style-type: none"> <li>1. Check that the machine controls are set correctly for the process.</li> </ol>	<ol style="list-style-type: none"> <li>1. Micro switch S2A may be faulty. It should “open” in the AC mode. See the Wiring Diagram.</li> </ol>

### CAUTION

If for any reason you do not understand the test procedures or are unable to perform the test/repairs safely, contact the Lincoln Electric Service Department for electrical troubleshooting assistance before you proceed. Call 1-888-935-3877.

PRECISION TIG 275



# TROUBLESHOOTING & REPAIR

## TROUBLESHOOTING GUIDE

Observe Safety Guidelines detailed in the beginning of this manual.

PROBLEMS (SYMPTOMS)	POSSIBLE AREAS OF MISADJUSTMENT(S)	RECOMMENDED COURSE OF ACTION
<b>STICK WELDING PROBLEMS</b>		
<p>The stick electrode “blasts-off” when touched to the work piece.</p> <p><b>NOTE: BEFORE REPLACING A CONTROL BOARD</b></p> <p>If an Advanced Control Panel is installed, remove it and replace the Jumper in connector J-3. If the machine functions normally, the Advanced Process panel or harness is defective.</p>	<ol style="list-style-type: none"> <li>1. Welding current may be too high for the electrode size. Reduce current control setting or use a larger diameter electrode.</li> </ol>	<ol style="list-style-type: none"> <li>1. Perform the <b>SCR Bridge Test</b>.</li> <li>2. The control board may be faulty.</li> </ol>
<p>Variable or sluggish welding arc when welding in the Stick mode.</p>	<ol style="list-style-type: none"> <li>1. Check the work and electrode cables for loose or poor connections.</li> <li>2. The welding cables may be too small or too long to permit the desired current to flow.</li> <li>3. The welding current may be set too low.</li> </ol>	<ol style="list-style-type: none"> <li>1. Check the polarity switch for excessive wear or faulty connections.</li> <li>2. Check the interior heavy current carrying leads and connections.</li> </ol>

⚠ CAUTION

If for any reason you do not understand the test procedures or are unable to perform the test/repairs safely, contact the Lincoln Electric Service Department for electrical troubleshooting assistance before you proceed. Call 1-888-935-3877.

PRECISION TIG 275



Return to Section TOC  
Return to Master TOC

# TROUBLESHOOTING & REPAIR

## TROUBLESHOOTING GUIDE

Observe Safety Guidelines detailed in the beginning of this manual.

PROBLEMS (SYMPTOMS)	POSSIBLE AREAS OF MISADJUSTMENT(S)	RECOMMENDED COURSE OF ACTION
<b>FUNCTION PROBLEMS</b>		
<p>The meter does not display V (volt) or minimum current.</p> <p><b>NOTE: BEFORE REPLACING A CONTROL BOARD</b></p> <p>If an Advanced Control Panel is installed, remove it and replace the Jumper in connector J-3. If the machine functions normally, the Advanced Process panel or harness is defective.</p>	<p>1. Check that either the advanced control board or jumper plug is in J3 on the control board.</p>	<p>1. Check R1 potentiometer and associated leads between the control board and plug J9. See the Wiring Diagram.</p> <p>2. The control board may be faulty.</p>

**⚠ CAUTION**

If for any reason you do not understand the test procedures or are unable to perform the test/repairs safely, contact the Lincoln Electric Service Department for electrical troubleshooting assistance before you proceed. Call 1-888-935-3877.

**PRECISION TIG 275**



Return to Section TOC

Return to Master TOC



**TROUBLESHOOTING GUIDE**

Observe Safety Guidelines detailed in the beginning of this manual.

PROBLEMS (SYMPTOMS)	POSSIBLE AREAS OF MISADJUSTMENT(S)	RECOMMENDED COURSE OF ACTION
<b>FUNCTION PROBLEMS</b>		
<p>The AC wave balance control does not function properly.</p> <p><b>NOTE: BEFORE REPLACING A CONTROL BOARD</b></p> <p>If an Advanced Control Panel is installed, remove it and replace the Jumper in connector J-3. If the machine functions normally, the Advanced Process panel or harness is defective.</p>	<p>1. The AC wave balance control is operational only in the TIG mode.</p>	<p>1. Check the AC balance control (R2) and associated leads for loose or faulty connections. See the Wiring Diagram.</p> <p>2. The control board may be faulty.</p>
<p>Gas pre-flow and post-flow time is too long.</p>	<p>1. If an advanced control board is installed, check dip switch setting on the board. See <i>Installation Manual</i>.</p>	<p>1. Check plug J3 on the control board. Either the jumper plug or the advanced control board must be plugged into J3.</p>

**⚠ CAUTION**

If for any reason you do not understand the test procedures or are unable to perform the test/repairs safely, contact the Lincoln Electric Service Department for electrical troubleshooting assistance before you proceed. Call 1-888-935-3877.

PRECISION TIG 275



Return to Section TOC  
Return to Master TOC

# TROUBLESHOOTING & REPAIR

## TROUBLESHOOTING GUIDE

Observe Safety Guidelines detailed in the beginning of this manual.

PROBLEMS (SYMPTOMS)	POSSIBLE AREAS OF MISADJUSTMENT(S)	RECOMMENDED COURSE OF ACTION
FUNCTION PROBLEMS		
<p>The meter does not display V (volt) or minimum current.</p> <p><b>NOTE: BEFORE REPLACING A CONTROL BOARD</b></p> <p>If an Advanced Control Panel is installed, remove it and replace the Jumper in connector J-3. If the machine functions normally, the Advanced Process panel or harness is defective.</p>	<p>1. Toggle the display switch. It may be dirty.</p>	<p>1. Check the leads between the display switch and the control board. See the Wiring Diagram.</p> <p>2. The display switch may be faulty.</p> <p>3. The control board may be faulty.</p>
<p>The meter does not light up. Other machine functions are OK.</p> <p><b>NOTE: BEFORE REPLACING A CONTROL BOARD</b></p> <p>If an Advanced Control Panel is installed, remove it and replace the Jumper in connector J-3. If the machine functions normally, the Advanced Process panel or harness is defective.</p>	<p>1. None</p>	<p>1. Check the leads and connections between the meter and the control board. See the Wiring Diagram.</p> <p>2. The meter may be faulty.</p> <p>3. The control board may be faulty.</p>

**CAUTION**

If for any reason you do not understand the test procedures or are unable to perform the test/repairs safely, contact the Lincoln Electric Service Department for electrical troubleshooting assistance before you proceed. Call 1-888-935-3877.

PRECISION TIG 275



Return to Section TOC

Return to Master TOC

Return to Section TOC

Return to Section TOC

Return to Section TOC

Return to Section TOC

Return to Master TOC

Return to Master TOC

Return to Master TOC

Return to Master TOC

PRECISION TIG 275



# TROUBLESHOOTING & REPAIR

## METER CALIBRATION ADJUSTMENTS

### WARNING

Service and repair should be performed by only Lincoln Electric factory trained personnel. Unauthorized repairs performed on this equipment may result in danger to the technician or machine operator and will invalidate your factory warranty. For your safety and to avoid electrical shock, please observe all safety notes and precautions detailed throughout this manual.

If for any reason you do not understand the test procedures or are unable to perform the test/repairs safely, contact the Lincoln Electric Service Department for electrical troubleshooting assistance before you proceed. Call 1-888-935-3877.

---

### DESCRIPTION

This test will help aid the technician in meter circuits calibration.

### MATERIALS NEEDED

Voltmeter/Ohmmeter  
3/8" Nut Driver  
Wiring Diagram

PRECISION TIG 275



METER CALIBRATION ADJUSTMENTS *(continued)*

FIGURE F.1 – TRIMMER

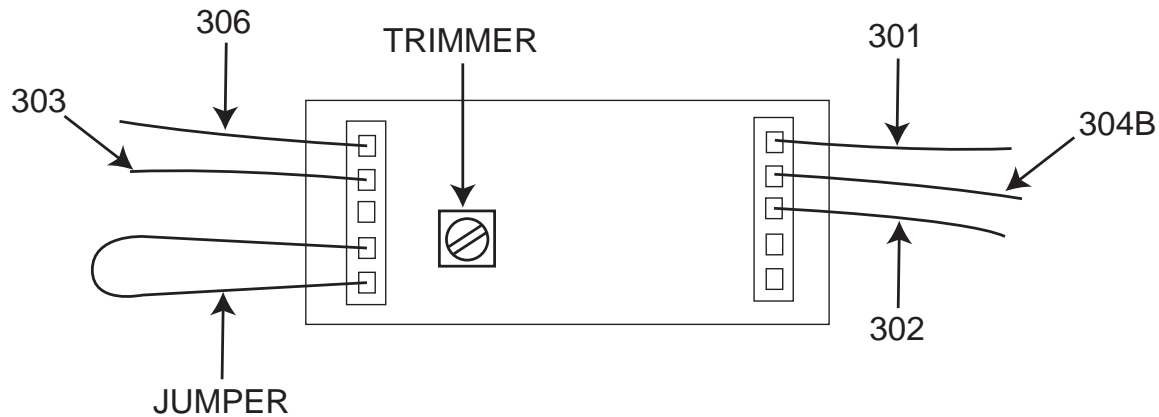

**Note:** The Precision TIG meter circuits are factory calibrated for the accuracy of the ammeter and voltmeter and should not need adjustment. However, the factory trimmers are accessible inside the control box:

## CALIBRATION CHECK

The Digital Meter Calibration Trimmer is located on the back of the meter housing near the right side connector plug (with two leads and a jumper attached). This trimmer adjusts calibration of the meter used for both ammeter and voltmeter readings, so its calibration should be checked first, as follows:

1. Set the TIG mode and, without closing the arc start switch, preset the panel maximum output control so the panel digital meter reads 200 amps.
2. Using a DC (avg.) digital test voltmeter with at least 0.5% accuracy at 1,000v, measure the DC voltage between (+) pin 2 (lead #303) and (-) pin 1 (lead #306) at the right side meter plug (nearest the trimmer).
3. This voltage should match the 200A panel meter reading (as 0.200v, or 200mv) within 1%. If not, adjust the trimmer so that the panel meter accuracy is corrected. (See Figure F.1)

PRECISION TIG 275





Return to Section TOC

Return to Section TOC

Return to Section TOC

Return to Section TOC

Return to Master TOC

Return to Master TOC

Return to Master TOC

Return to Master TOC

PRECISION TIG 275





## HIGH FREQUENCY CIRCUIT DISABLE PROCEDURE

### WARNING

Service and repair should be performed by only Lincoln Electric factory trained personnel. Unauthorized repairs performed on this equipment may result in danger to the technician or machine operator and will invalidate your factory warranty. For your safety and to avoid electrical shock, please observe all safety notes and precautions detailed throughout this manual.

If for any reason you do not understand the test procedures or are unable to perform the test/repairs safely, contact the Lincoln Electric Service Department for electrical troubleshooting assistance before you proceed. Call 1-888-935-3877.

### DESCRIPTION

This procedure will disable the high frequency circuit allowing the technician to take voltage measurements without the possibility of high frequency damage to his test equipment.

### MATERIALS NEEDED

3/8" Nut Driver  
Electrical Insulating Tape

PRECISION TIG 275



## HIGH FREQUENCY CIRCUIT DISABLE PROCEDURE *(continued)*

FIGURE F.2 – SPARK GAP ASSEMBLY

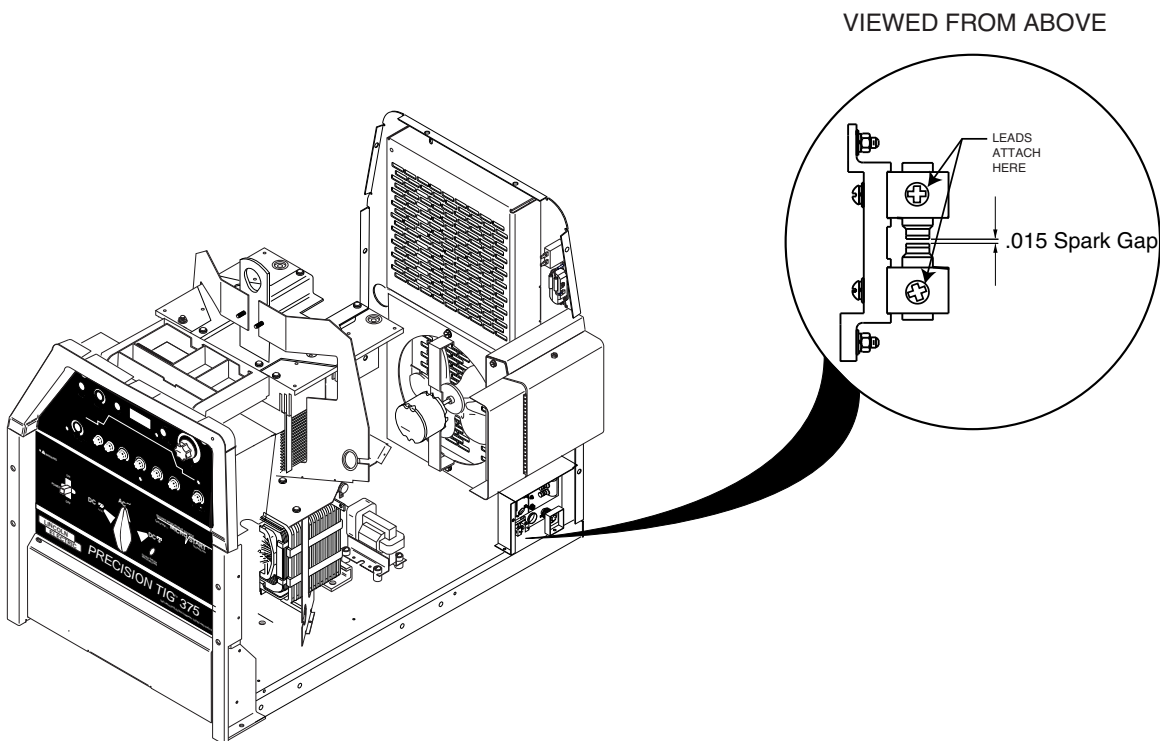

### PROCEDURE

1. Remove the input power to the PRECISION TIG 275 machine.
2. Using the 3/8" nut driver, remove the right side case cover.
3. Locate the Spark Gap Assembly at the lower rear right side of the machine. See Figure F.2.
4. Carefully remove the three leads from the Spark Gap Assembly. See Figure F.2.
5. Insulate the leads from each other and from the case.
6. When voltage testing and scope measurements are complete, reconnect the three leads to the Spark Gap Assembly.
7. Reassemble the right side case cover.

PRECISION TIG 275



## PROTECTION BOARD TEST

### WARNING

Service and repair should be performed by only Lincoln Electric factory trained personnel. Unauthorized repairs performed on this equipment may result in danger to the technician or machine operator and will invalidate your factory warranty. For your safety and to avoid electrical shock, please observe all safety notes and precautions detailed throughout this manual.

If for any reason you do not understand the test procedures or are unable to perform the test/repairs safely, contact the Lincoln Electric Service Department for electrical troubleshooting assistance before you proceed. Call 1-888-935-3877.

---

### TEST DESCRIPTION

This procedure will determine if the Protection board is functioning properly.

### MATERIALS NEEDED

3/8" Nut Driver  
Voltmeter/Ohmmeter (Multimeter)  
Tig 275 Wiring Diagrams

PRECISION TIG 275



Return to Section TOC

Return to Section TOC

Return to Section TOC

Return to Section TOC

Return to Master TOC

Return to Master TOC

Return to Master TOC

Return to Master TOC

## PROTECTION BOARD TEST *(continued)*

- Using a 3/8" nut driver, remove the case top and sides.
- Check that P5 is connected to J5, not J5A. See the Wiring Diagram.
- Unplug P5 from the control board. Measure resistance at P5. See Figure F3. See tables below.

**Table F.1**

	RESISTANCE BETWEEN	READING
TRIGGER	Pins 5 & 7	Open when trigger open, short when trigger closed.
B-C	Pins 3 & 4	Increasing from 0 to 10K when working on remote amptrol from min. to max.
B-A	Pins 2 & 3	Decreasing from 10K to 0 when working on remote amptrol from min. to max.

- If the readings above are OK, the protection board is OK. If not, go to step 5.
- Unplug P23 from the protection board and check continuity from P23 to P5. If OK, go to step 6. See Wiring Diagram.
- Unplug P22 from protection board. Measure resistance at P22. See Tables.
- If readings below are OK, protection board is bad.
- If readings below are wrong, remote amptrol or remote receptacle is bad.

**Table F.2**

	RESISTANCE BETWEEN	READING
TRIGGER	Pins 3 & 6	Open when trigger open, short when trigger closed.
B-C	Pins 1 & 2	Increasing from 0 to 10K when working on remote amptrol from min. to max.
B-A	Pins 1 & 4	Decreasing from 10K to 0 when working on remote amptrol from min. to max.

**FIGURE F.3 – Plug J5 (viewed from pin end)**

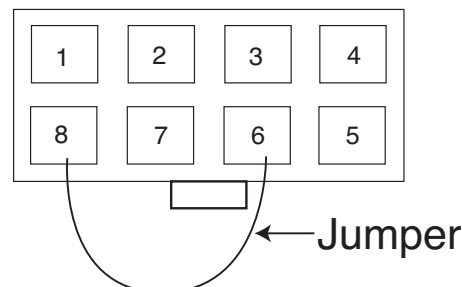

PRECISION TIG 275



Return to Section TOC

Return to Section TOC

Return to Section TOC

Return to Master TOC

Return to Master TOC

Return to Master TOC

## T1 MAIN TRANSFORMER TEST

### WARNING

Service and repair should be performed by only Lincoln Electric factory trained personnel. Unauthorized repairs performed on this equipment may result in danger to the technician or machine operator and will invalidate your factory warranty. For your safety and to avoid electrical shock, please observe all safety notes and precautions detailed throughout this manual.

If for any reason you do not understand the test procedures or are unable to perform the test/repairs safely, contact the Lincoln Electric Service Department for electrical troubleshooting assistance before you proceed. Call 1-888-935-3877.

---

### DESCRIPTION

This procedure will determine if the correct voltage is being applied to the primary of the T1 transformer and also if the correct voltages are being induced on the secondary windings of the transformer.

### MATERIALS NEEDED

3/8" Nut Driver  
Voltmeter/Ohmmeter (Multimeter)  
Tig 275 Wiring Diagrams

PRECISION TIG 275



## T1 MAIN TRANSFORMER TEST (continued)

Figure F.4 Plug J11

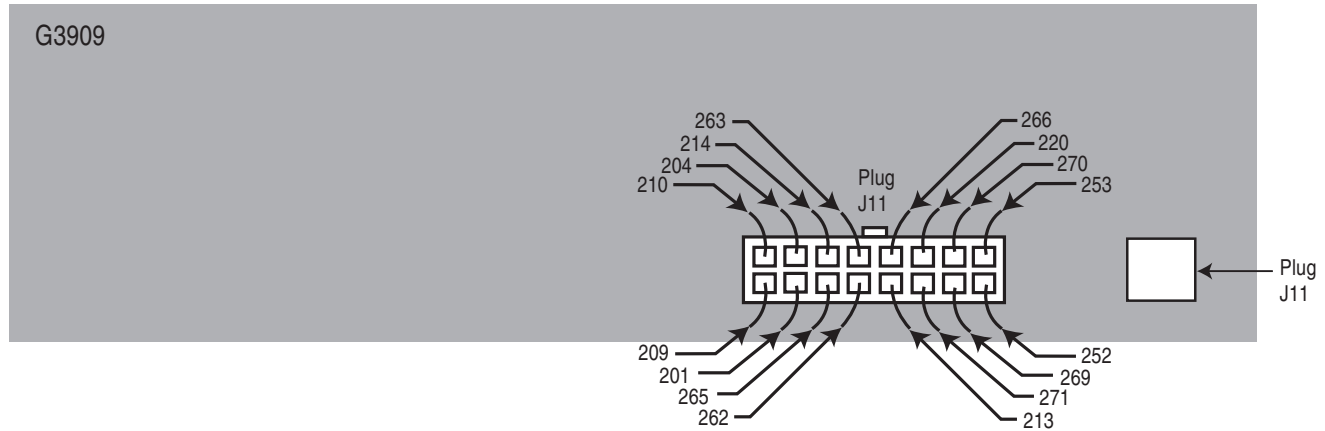

## TEST PROCEDURES

- Using the 3/8" nut driver, remove the two screws from the front control panel. Carefully lower the panel. This will allow access to the control board.
- Locate plug J11 on the control board. See Figure F.4.

**⚠ WARNING**

**ELECTRIC SHOCK can kill.**

\*With input power ON, there are high voltages inside the machine. Do not reach into the machine or touch any internal part.



- Carefully apply the correct input power making certain the reconnect configuration at the reconnect panel is correct for the input voltage applied. Turn the Precision TIG 275 ON.
- Using the voltmeter, carefully test for the correct transformer secondary voltages per **Table F.3**.

- Carefully check for 63.5 VAC at leads 267 to lead 268. Lead 268 is located at the background rectifier.

Note: Lead 267 is located at resistor R8. See Wiring Diagram.

- Carefully check for 115 VAC at leads 231 to 232.

Note: Lead 231 is located at the 115 VAC receptacle on the back of the machine. Lead 232 is located at the 15 amp circuit breaker CB1.

- If all of the secondary voltages are correct, the T1 transformer is functioning properly.

a. If all of the secondary voltages are missing or incorrect, make certain that the correct input voltage is being applied to the correct primary leads. **See Table F.3.**

b. If the correct input voltage is being applied to the primary leads and any or all of the secondary voltages are incorrect, the T1 transformer may be faulty. Also check the leads for broken or loose connections between plug J11 and the T1 transformer.

- Replace the case side covers.

PRECISION TIG 275



## T1 MAIN TRANSFORMER TEST *(continued)*

Table F.3 - T1 Transformer Voltages

TEST POINTS	ACCEPTABLE VOLTAGES
<b>SECONDARY WINDINGS</b>	<b>SECONDARY VOLTAGES</b>
PLUG J11 PIN 8 (LEAD W209) TO PLUG J11 PIN 16 (LEAD R210)	20 VAC
PLUG J11 PIN 7 (LEAD #201) TO PLUG J11 PIN 15 (LEAD #204)	18VAC
X1 TO X2	78 VAC
<b>PRIMARY WINDINGS</b>	<b>PRIMARY VOLTAGES</b>
H1 TO H2	208 VAC
H1 TO H3	230 VAC
H1 TO H4	460 VAC

NOTE: If the input voltages vary, the secondary voltages will vary accordingly.

Based on 208/230/460 models. For other voltage models refer to appropriate Wiring Diagram.

PRECISION TIG 275





Return to Section TOC

Return to Section TOC

Return to Section TOC

Return to Section TOC

Return to Master TOC

Return to Master TOC

Return to Master TOC

Return to Master TOC

## GAS (WATER) SOLENOID TEST

### WARNING

Service and repair should be performed by only Lincoln Electric factory trained personnel. Unauthorized repairs performed on this equipment may result in danger to the technician or machine operator and will invalidate your factory warranty. For your safety and to avoid electrical shock, please observe all safety notes and precautions detailed throughout this manual.

If for any reason you do not understand the test procedures or are unable to perform the test/repairs safely, contact the Lincoln Electric Service Department for electrical troubleshooting assistance before you proceed. Call 1-888-935-3877.

---

### TEST DESCRIPTION

This procedure will help the technician to determine if the solenoid is receiving the correct voltage also if the solenoid is functional.

### MATERIALS NEEDED

3/8" Nut Driver  
Voltmeter/Ohmmeter (Multimeter)  
Isolated 115 VAC Power Supply

PRECISION TIG 275



## GAS (WATER) SOLENOID TEST *(continued)*

### TEST PROCEDURE

1. Remove input power to the Precision TIG 275 machine.
2. Remove the left case side.
3. Perform the **High Frequency Circuit Disable Procedure**.
4. Locate the gas solenoid in the torch connection box.
5. Put the mode switch S3 in the 2-Step TIG position.
6. Apply the correct input power to the TIG 275.
7. Activate the torch trigger and check for approximately 115 VAC at the solenoid leads (#231A and # 235). If the correct voltage is present, the solenoid should activate and gas should flow.
8. If voltage is present at leads #231A and #235 and the solenoid does not activate, the solenoid may be defective. The solenoid can be further checked by removing leads #231A and #235 from the solenoid and applying the external isolated 115 VAC supply to the solenoid terminals. If the solenoid activates with the external supply but not when powered by the control board, the problem may be in the control board. If you hear solenoid activation but there is still no gas flow, check for restrictions in the line.
9. When the test is complete, replace leads #231A and #235.
10. Reassemble the two leads previously removed in the **High Frequency Circuit Disable Procedure**.
11. Reassemble the left case side.
12. If a water solenoid is used, it can be tested using the same procedures.



### WARNING



#### ELECTRIC SHOCK CAN KILL.

\*With input power ON, there are high voltages inside the machine. Do not reach into the machine or touch any internal part.

PRECISION TIG 275



## STATIC SCR TEST

### WARNING

Service and repair should be performed by only Lincoln Electric factory trained personnel. Unauthorized repairs performed on this equipment may result in danger to the technician or machine operator and will invalidate your factory warranty. For your safety and to avoid electrical shock, please observe all safety notes and precautions detailed throughout this manual.

If for any reason you do not understand the test procedures or are unable to perform the test/repairs safely, contact the Lincoln Electric Service Department for electrical troubleshooting assistance before you proceed. Call 1-888-935-3877.

---

### DESCRIPTION

The SCR test is a quick check to determine if an SCR is “shorted” or “leaky”. See machine waveform section for normal and abnormal SCR waveforms.

### MATERIALS NEEDED

- 3/8” Nut Driver
- Analog Ohmmeter (Multimeter)
- Tig 275 Wiring Diagrams
- SCR Heatsink Assembly Drawing

PRECISION TIG 275



## STATIC SCR TEST *(continued)*

### Figure F.5 - Plug J4 Location



### TEST PROCEDURE

1. Remove main supply power to the PRECISION TIG 275 and remove the case top and left side.
2. Locate and remove plug J4 from the control board. See Figure F.5.
3. Using an analog ohmmeter, test the resistance from anode to cathode of SCR1. Reverse the meter leads and check from cathode to anode of SCR1. See Figure F.5. If a low resistance is indicated in either direction, SCR1 is faulty. Replace the SCR Bridge Assembly. See **SCR Bridge Assembly**

### Removal and Replacement.

4. Repeat Step #3 testing SCR2, SCR3 and SCR4.
  5. To further check the SCR's functions, use an SCR tester and proceed to the **Active SCR Test**.
- NOTE:** Also check diode D1.
6. Replace plug J4 on the control board.
  7. Replace the case top and left side.

### Figure F.6 - SCR TEST POINTS

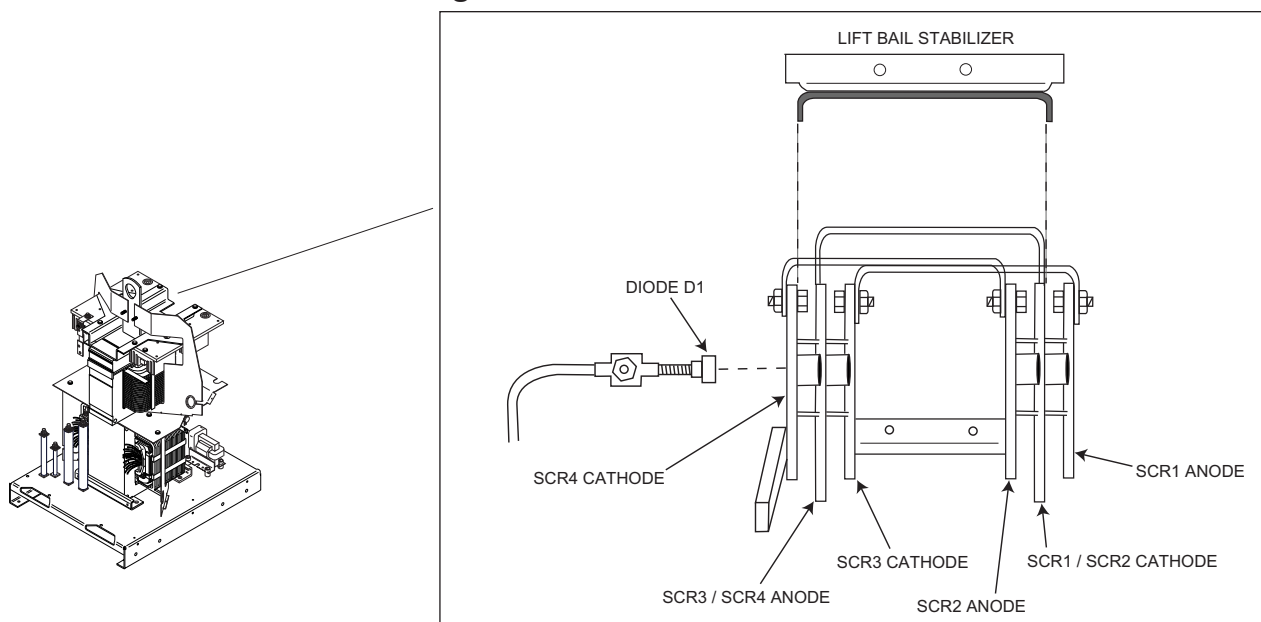

PRECISION TIG 275



## ACTIVE SCR TEST

### WARNING

Service and repair should be performed by only Lincoln Electric factory trained personnel. Unauthorized repairs performed on this equipment may result in danger to the technician or machine operator and will invalidate your factory warranty. For your safety and to avoid electrical shock, please observe all safety notes and precautions detailed throughout this manual.

If for any reason you do not understand the test procedures or are unable to perform the test/repairs safely, contact the Lincoln Electric Service Department for electrical troubleshooting assistance before you proceed. Call 1-888-935-3877.

---

### DESCRIPTION

The Active SCR test will determine if the device is able to be gated "ON" and conduct current from anode to cathode.

### MATERIALS NEEDED

3/8" Nut Driver  
TIG 275 Wiring Diagrams  
An SCR Tester as Outlined in this Procedure

PRECISION TIG 275



**ACTIVE SCR TEST** (continued)**Figure F.7 - Plug J4 Location****TEST PROCEDURE**

1. Remove main supply power to the PRECISION TIG 275 machine.
2. Locate and remove plug J4 from the control board. See Figure F.7.
3. Perform the following test for all four SCRs. See **Figure F.8**.
4. Construct the circuit outline in **Figure F.8**. One 6V lantern battery can be used. Resistor values are  $\pm 10\%$ . The voltmeter scale should be approximately 0-5 or 0-10 volts.
5. **Battery Test** - Check the battery by shorting leads (A) and (C) and then close switch SW-1. Replace the battery if voltage is less than 4.5 volts.

PRECISION TIG 275



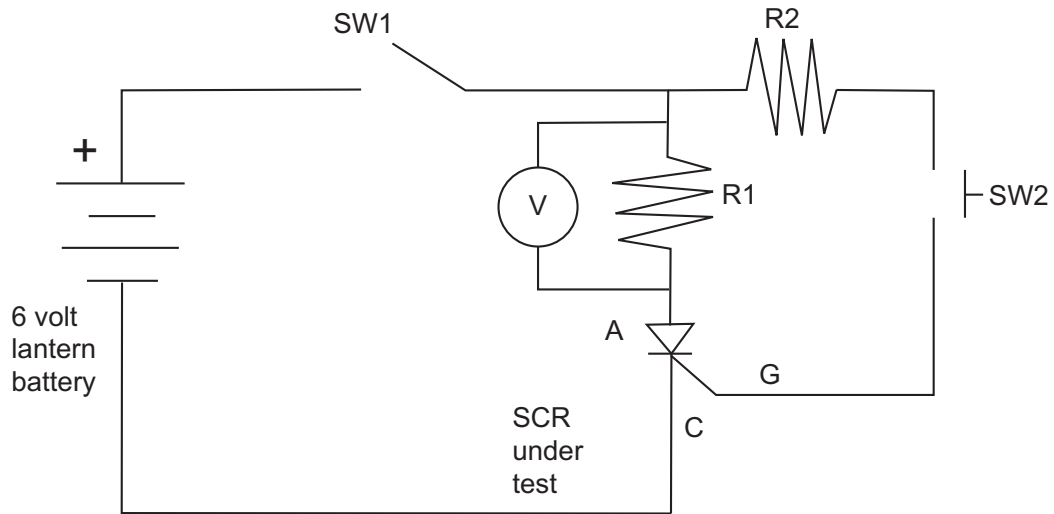

**ACTIVE SCR TEST** *(continued)***Figure F.8 - Active SCR Test Set-Up**

R1 = 4 ohms / 10 watts

R2 = 3 ohms / 10 watts

Resistor values are +/- 10%

PRECISION TIG 275

**LINCOLN**<sup>®</sup>  
**ELECTRIC**

Return to Section TOC

Return to Section TOC

Return to Section TOC

Return to Section TOC

Return to Master TOC

Return to Master TOC

Return to Master TOC

Return to Master TOC

## ACTIVE SCR TEST (continued)

### Figure F.9 - SCR Gate Locations

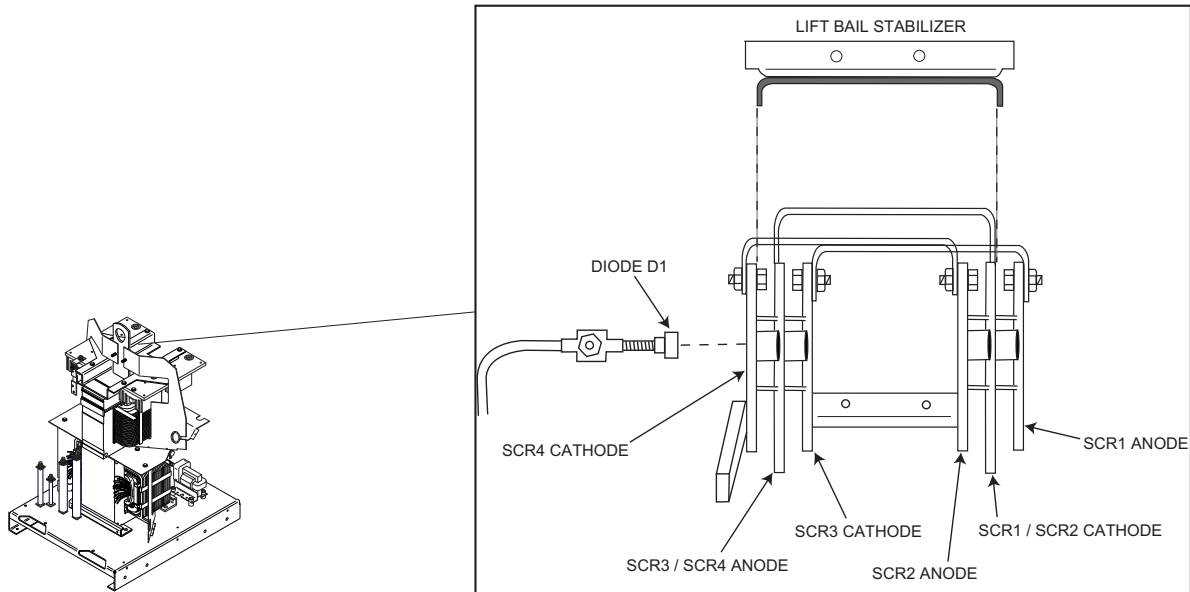

6. Connect SCR into the test circuit as shown in **Figure F.8**. (A)Lead to anode (C) lead to cathode and (G) lead to the gate.
7. Close switch SW-1 (Switch SW-2 should be open). The voltmeter should read zero. If the voltmeter reads higher than zero, the SCR is shorted.
8. With switch SW-1 closed, close switch SW-2 for two seconds and release. The voltmeter should read 3 to 6 volts before and after switch SW-2 is released. If the voltmeter does not read, or reads only while SW-2 is depressed, the SCR or battery is defective. (Repeat Battery Test Procedure described in Step 5.)
9. Open switch SW-1, disconnect the gate lead (G) and reverse the (A) and (C) leads on the SCR. Close switch SW-1. The voltmeter should read zero. If the voltage is higher than zero, the SCR is shorted.
10. Replace any SCRs that do not pass the test. See **SCR Bridge Assembly Removal and Replacement**.
11. Replace plug J4 on the control board.
12. Replace the case sides and top.

PRECISION TIG 275





# TROUBLESHOOTING & REPAIR

## TYPICAL OUTPUT VOLTAGE WAVEFORM - MACHINE LOADED TO 200 AMPS AC - TIG MODE

**HIGH VOLTAGE/ HIGH FREQUENCY can damage test equipment.**

Perform all voltage and waveform checks with high frequency circuit OFF.

Perform High Frequency Disable Procedure.

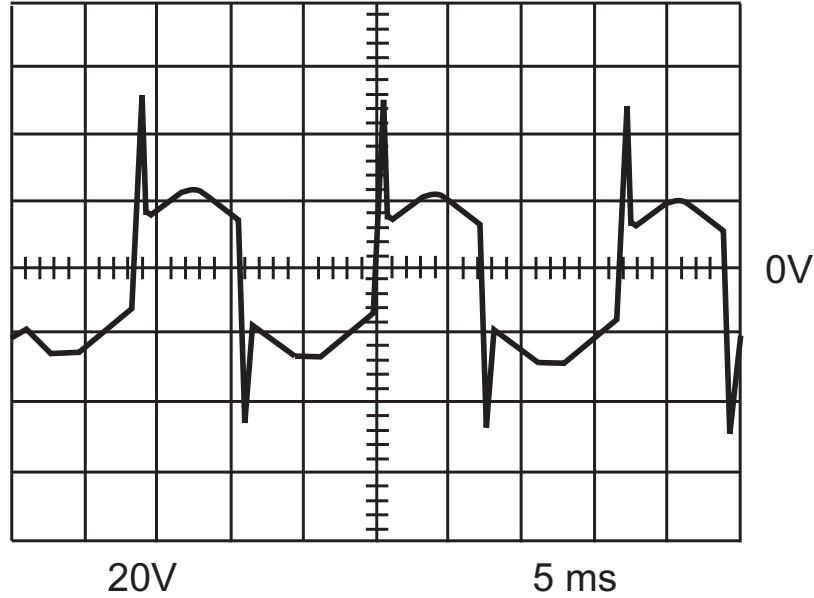

### AC BALANCE CONTROL IN “AUTO”

This is the typical AC output voltage waveform generated from a properly operating machine. Note that each vertical division represents 20 volts and that each horizontal division represents 5 milliseconds in time. The machine was loaded with a resistance grid bank.

**NOTE:** Scope probes connected at machine output terminals: (+) probe to electrode, (-) probe to work.

### SCOPE SETTINGS

Volts/Div.....	20V/Div.
Horizontal Sweep.....	5 ms/Div.
Coupling.....	DC
Trigger.....	Internal

PRECISION TIG 275



Return to Section TOC

Return to Section TOC

Return to Section TOC

Return to Section TOC

Return to Master TOC

Return to Master TOC

Return to Master TOC

Return to Master TOC

### TYPICAL AC VOLTAGE WAVEFORM - MACHINE LOADED TO 50 AMPS AC - TIG MODE

**HIGH VOLTAGE/ HIGH FREQUENCY** can damage test equipment.

Perform all voltage and waveform checks with high frequency circuit OFF.

Perform High Frequency Disable Procedure.

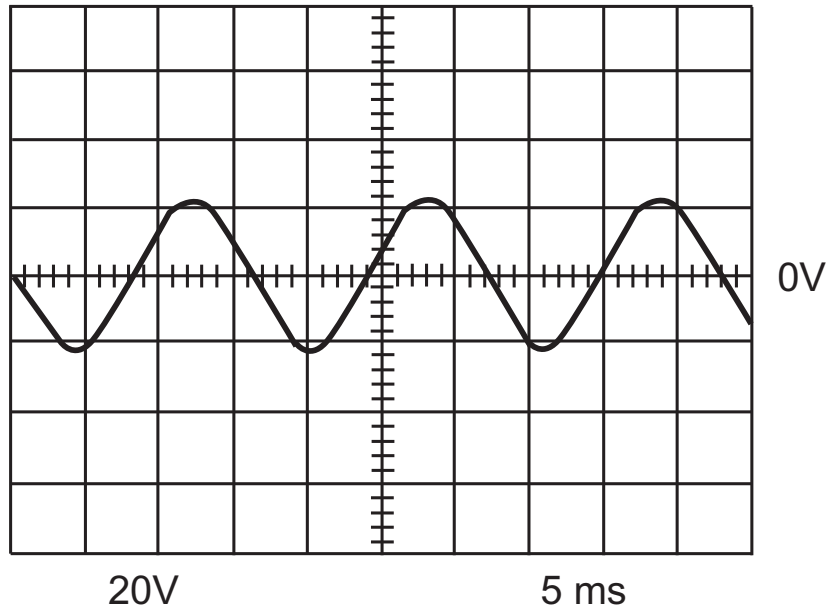

#### AC BALANCE CONTROL IN "AUTO"

This is the typical DC (+) output voltage waveform generated from a properly operating machine. Note that each vertical division represents 20 volts and that each horizontal division represents 5 milliseconds in time.

**NOTE:** Scope probes connected at machine output terminals: (+) probe to electrode, (-) probe to work.

#### SCOPE SETTINGS

Volts/Div.....	20V/Div.
Horizontal Sweep.....	5 ms/Div.
Coupling.....	DC
Trigger.....	Internal

PRECISION TIG 275



Return to Section TOC

Return to Section TOC

Return to Section TOC

Return to Section TOC

Return to Master TOC

Return to Master TOC

Return to Master TOC

Return to Master TOC



TYPICAL OUTPUT VOLTAGE WAVEFORM - MACHINE LOADED TO 200 AMPS  
DC - TIG MODE

**HIGH VOLTAGE/ HIGH FREQUENCY can damage test equipment.**

Perform all voltage and waveform checks with high frequency circuit OFF.

Perform High Frequency Disable Procedure.

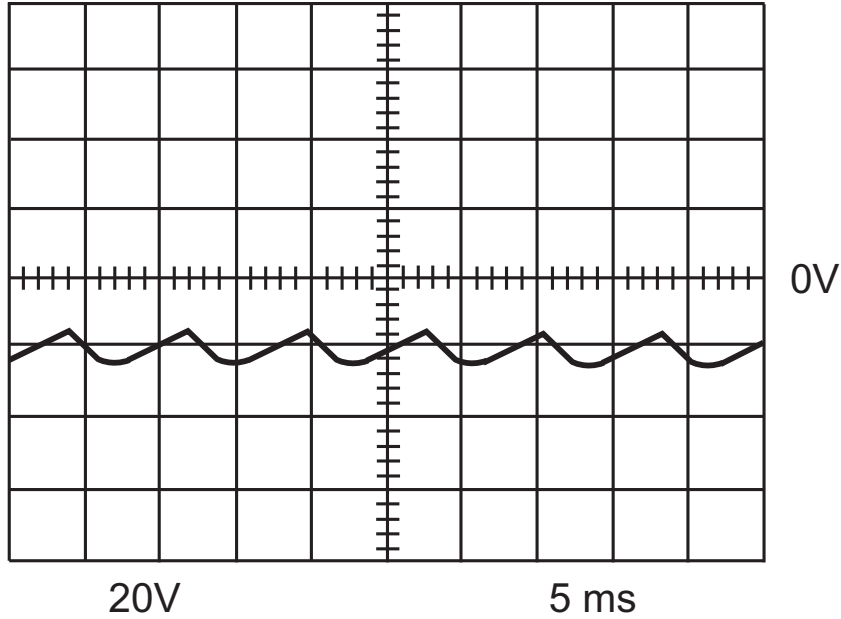

This is the typical AC output voltage waveform generated from a properly operating machine. Note that each vertical division represents 20 volts and that each horizontal division represents 5 milliseconds in time.

**NOTE:** Scope probes connected at machine output terminals: (+) probe to electrode, (-) probe to work.

**NOTE:** AC balance control set at "Balanced" position.

**SCOPE SETTINGS**

Volts/Div.....	20V/Div.
Horizontal Sweep.....	5 ms/Div.
Coupling.....	DC
Trigger.....	Internal

PRECISION TIG 275



Return to Section TOC  
Return to Section TOC  
Return to Section TOC  
Return to Section TOC  
Return to Section TOC

Return to Master TOC  
Return to Master TOC  
Return to Master TOC  
Return to Master TOC  
Return to Master TOC



Return to Section TOC

Return to Section TOC

Return to Section TOC

Return to Section TOC

Return to Master TOC

Return to Master TOC

Return to Master TOC

Return to Master TOC

PRECISION TIG 275



## HIGH VOLTAGE TRANSFORMER REMOVAL AND REPLACEMENT

### WARNING

Service and repair should be performed by only Lincoln Electric factory trained personnel. Unauthorized repairs performed on this equipment may result in danger to the technician or machine operator and will invalidate your factory warranty. For your safety and to avoid electrical shock, please observe all safety notes and precautions detailed throughout this manual.

If for any reason you do not understand the test procedures or are unable to perform the test/repairs safely, contact the Lincoln Electric Service Department for electrical troubleshooting assistance before you proceed. Call 1-888-935-3877.

---

### DESCRIPTION

This procedure will aid the technician in the removal and replacement of the high voltage transformer.

### MATERIALS NEEDED

3/8" Nut Driver  
7/16" Nut Driver  
Phillips Head Screwdriver (Off-set)  
Wire Cutters

PRECISION TIG 275



## HIGH VOLTAGE TRANSFORMER REMOVAL AND REPLACEMENT *(continued)*

Figure F.10 - High Voltage Transformer

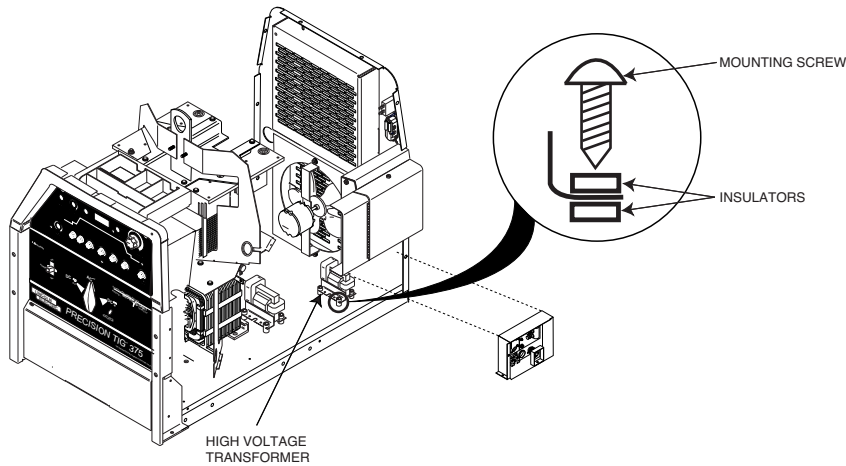

### REMOVAL PROCEDURE

1. Remove input power to the TIG 275 machine.
2. Using the 3/8" nut driver, remove the case sides and top.
3. Using a 3/8" nut driver, remove the case back.

Note: The case back will be connected to the fan assembly and will have leads connected to it, so just set aside.

4. Cut any necessary cable ties.
5. Disconnect black lead from the high voltage transformer connecting to leads 231D and 231E.
6. Disconnect the black lead from the high voltage transformer connecting to the capacitor. It may be necessary to cut lead.
7. Using a 7/16" nut driver disconnect heavy black leads S and F. **See Figure F.11.**
8. Using a 3/8" nut driver, remove the screw securing the spark gap assembly box. **See Figure F.11.** This will allow access to the high voltage transformer mounting screws.

9. Using an off set phillips head screw driver, remove the four high voltage transformer mounting screws. Note insulator positioning. See Figure F.10.
10. Remove the high voltage transformer.

### REPLACEMENT PROCEDURE

1. Replace the high voltage transformer.
2. Secure the new transformer using the four phillips head mounting screws. Refer to Figure F10 for insulator location.
3. Replace the 3/8" screw securing the spark gap assembly box.
4. Reconnect leads S and F.
5. Reconnect high voltage transformer lead to the capacitor.
6. Reconnect leads 231D and 231E to single black lead.
7. Replace any necessary cable ties.
8. Secure the case back using the 3/8" mounting bolts previously removed.
9. Replace the case sides and top.

PRECISION TIG 275



# HIGH VOLTAGE TRANSFORMER REMOVAL AND REPLACEMENT *(continued)*

Figure F.11 - 3/8" Screw & Leads S and F Locations

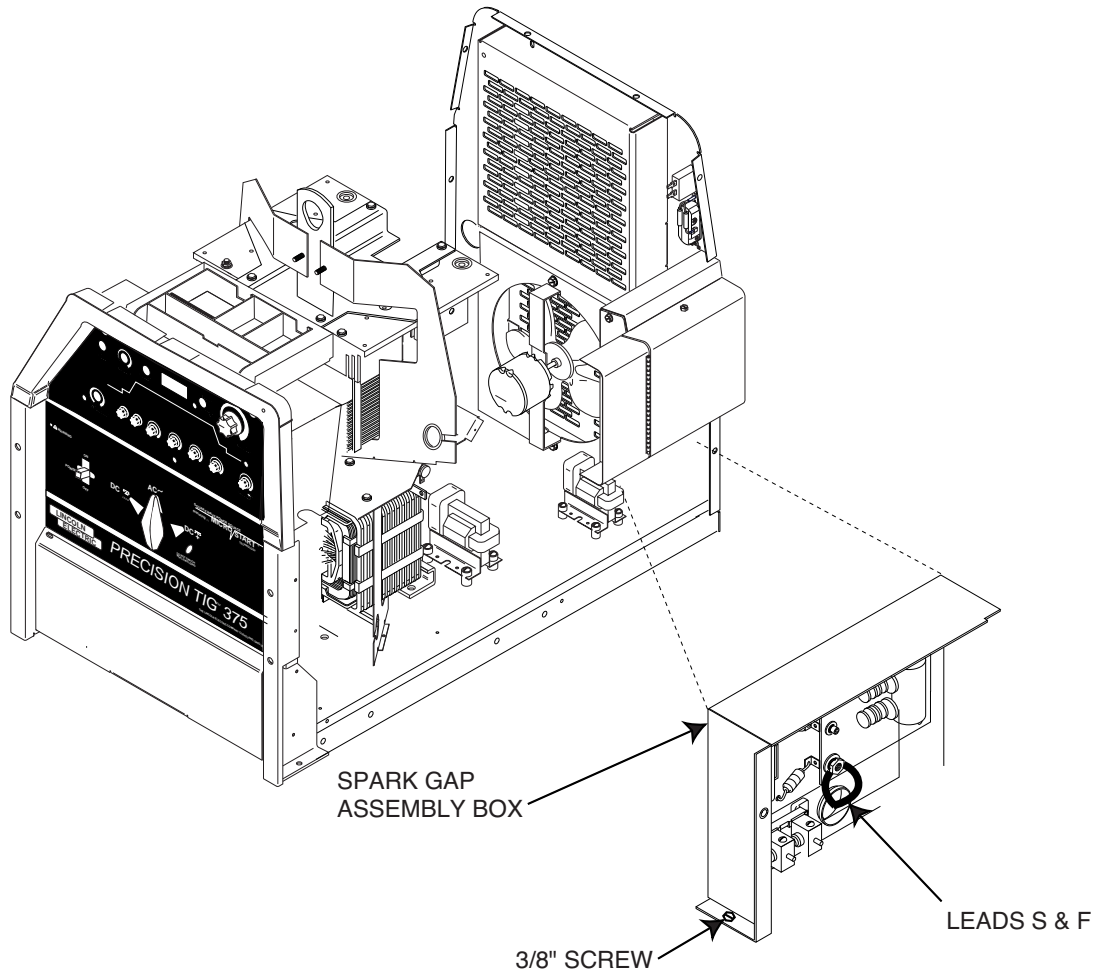

PRECISION TIG 275



Return to Section TOC  
Return to Section TOC  
Return to Section TOC  
Return to Section TOC  
Return to Master TOC  
Return to Master TOC  
Return to Master TOC  
Return to Master TOC

Return to Section TOC

Return to Section TOC

Return to Section TOC

Return to Section TOC

Return to Master TOC

Return to Master TOC

Return to Master TOC

Return to Master TOC

PRECISION TIG 275



## CONTROL BOARD REMOVAL AND REPLACEMENT

### WARNING

Service and repair should be performed by only Lincoln Electric factory trained personnel. Unauthorized repairs performed on this equipment may result in danger to the technician or machine operator and will invalidate your factory warranty. For your safety and to avoid electrical shock, please observe all safety notes and precautions detailed throughout this manual.

If for any reason you do not understand the test procedures or are unable to perform the test/repairs safely, contact the Lincoln Electric Service Department for electrical troubleshooting assistance before you proceed. Call 1-888-935-3877.

---

### DESCRIPTION

This procedure will aid the technician in the removal and replacement of the control board.

### MATERIALS NEEDED

3/8" Nut Driver  
Phillips Head Screwdriver  
Wire Cutters

PRECISION TIG 275



Return to Section TOC

Return to Section TOC

Return to Section TOC

Return to Section TOC

Return to Master TOC

Return to Master TOC

Return to Master TOC

Return to Master TOC

## CONTROL BOARD REMOVAL AND REPLACEMENT *(continued)*

Figure F.12 - Case Front Screw Location

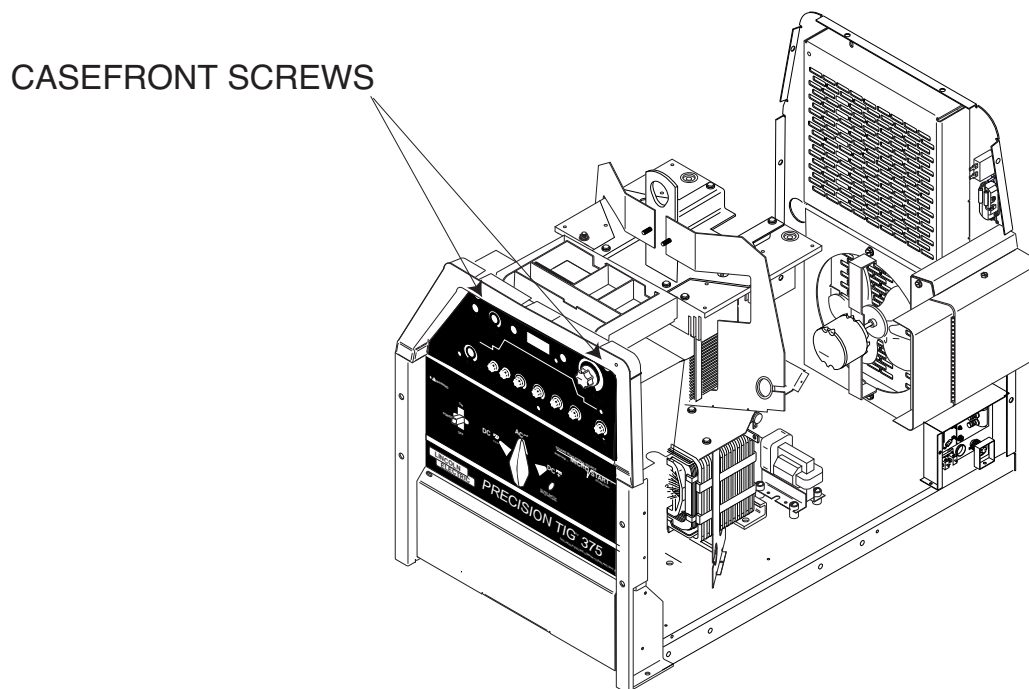

### REMOVAL PROCEDURE

1. Remove input power to the TIG 275 machine.
2. Using a 3/8" nut driver, remove the two screws from the top of the case front. See Figure F.12.
3. The top front control box cover can now be tilted forward to gain access to the control board and its plugs.
4. From left to right, label and disconnect plugs J4, J5, J6, J8, J9, J10, J11, J12. **See Figure F.13.**
5. Cut any necessary cable ties.
6. Using a phillips head screwdriver, remove the eight P.C. Board mounting screws. **See Figure F.13.**
7. Carefully maneuver the control board out of the front of the machine.

### REPLACEMENT PROCEDURE

1. Replace the control board.
2. Mount the new control board in its proper position using the eight phillips head mounting screws.
3. Replace any necessary cable ties.
4. Reconnect plugs previously removed from the control board.
5. Secure the control box assembly using the two 3/8" mounting screws previously removed.

PRECISION TIG 275



CONTROL BOARD REMOVAL AND REPLACEMENT *(continued)*

Figure F.13 - Control Board Plug Locations

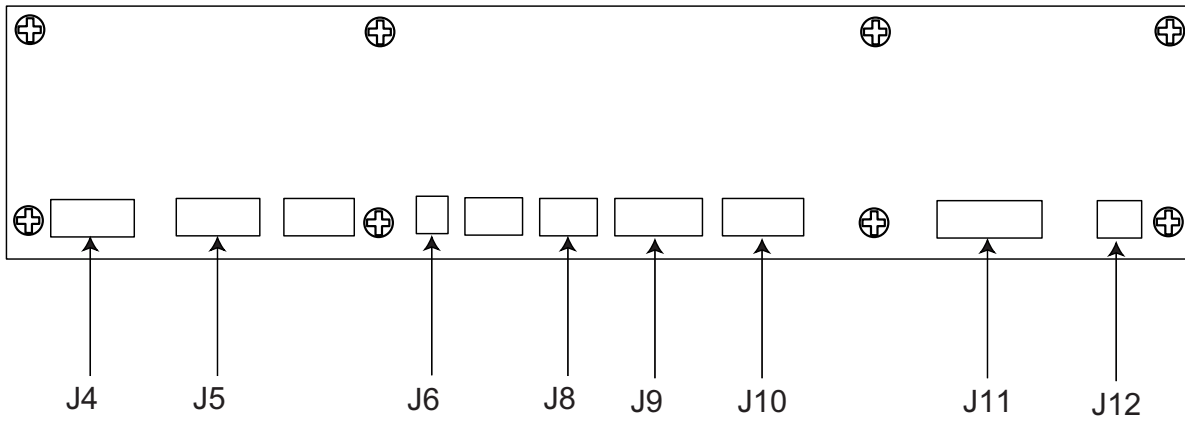

PRECISION TIG 275



Return to Section TOC

Return to Section TOC

Return to Section TOC

Return to Section TOC

Return to Master TOC

Return to Master TOC

Return to Master TOC

Return to Master TOC



Return to Section TOC

Return to Section TOC

Return to Section TOC

Return to Section TOC

Return to Master TOC

Return to Master TOC

Return to Master TOC

Return to Master TOC

PRECISION TIG 275



## SCR BRIDGE ASSEMBLY REMOVAL AND REPLACEMENT

### WARNING

Service and repair should be performed by only Lincoln Electric factory trained personnel. Unauthorized repairs performed on this equipment may result in danger to the technician or machine operator and will invalidate your factory warranty. For your safety and to avoid electrical shock, please observe all safety notes and precautions detailed throughout this manual.

If for any reason you do not understand the test procedures or are unable to perform the test/repairs safely, contact the Lincoln Electric Service Department for electrical troubleshooting assistance before you proceed. Call 1-888-935-3877.

---

### DESCRIPTION

This procedure will aid the technician in the removal and replacement of the SCR bridge for maintenance or replacement.

### MATERIALS NEEDED

- 3/8" Nut Driver
- 1/2" Nut Driver
- 7/16" Nut Driver
- Pliers
- Crimp Wire Cutters

PRECISION TIG 275



## SCR BRIDGE ASSEMBLY REMOVAL AND REPLACEMENT *(continued)*

### REMOVAL PROCEDURE

1. Remove input power to the TIG 275 machine.
2. Using the 3/8" nut driver, remove the case sides and top.
3. Label and cut leads G1 and G2. **See Figure F.14.**
4. Label and cut leads G3 and G4. **See Figure F.14.**
5. Remove the 1/2 " nut securing leads B and 217. **See Figure F.14.**
6. Using a 7/16" nut driver, disconnect Pos. lead and lead 218. **See Figure F.14.**
7. Using a 1/2" nut driver, disconnect Pos. lead and lead 218. **See Figure F.14.**
8. Using a 1/2" nut driver, remove lead 216 and aluminum lead X1 connecting to the main transformer. **See Figure F.14.** Note washer placement upon removal.
9. Using a 1/2" nut driver, disconnect lead 220A and shunt from the output bridge. **See Figure F.14.**
10. Using a 3/8" nut driver, remove the four SCR bridge mounting bolts. Note insulator washer placement upon removal.

### REPLACEMENT PROCEDURE

1. Replace the SCR bridge.
2. Replace the four SCR bridge mounting bolts previously removed.  
**Note:** Be sure to replace insulating washers in their proper positions.
3. Reconnect lead 218 and Pos. lead previously removed.
4. Replace the shunt and lead 220A previously removed.
5. Replace the 1/2" bolt securing lead 216 and the aluminum lead X1 originating from the main transformer.
6. Reconnect the negative lead to the free wheeling diode.
7. Replace the 1/2" bolt securing leads B and 217 previously removed.
8. Reconnect leads G1, G2, G3, and G4. Splice, solder and insulate as necessary.
9. Replace case sides and top.

PRECISION TIG 275



Return to Section TOC  
Return to Master TOC

Return to Section TOC  
Return to Master TOC

Return to Section TOC  
Return to Master TOC

Return to Section TOC  
Return to Master TOC



## TROUBLESHOOTING & REPAIR

### MOUNTING OF STUD TYPE DIODES TO ALUMINUM HEAT SINKS (CONT'D)

#### PROCEDURE

1. Loosen the appropriate diode nut and remove the diode that is to be replaced.
2. Clean the area on the heat sink around the diode mounting surface using a putty knife, or similar tool, DO NOT SCRATCH THE DIODE MOUNTING SURFACE.
3. Polish each heat sink's mounting surface using NO. 000 fine steel wool. Wipe surface clean with a lint free cloth or paper towel.
4. Inspect the mounting surfaces of each new diode. Remove all burrs and wipe clean. Do not use steel wool or any abrasive cleanser on the diode mounting surface.
5. Apply a thin (0.0003" to 0.0007") uniform layer of E1868 (Dow Corning 340) heat sink compound to the heat sink mounting surface.
  - a. Do not apply compound to diode stud or mounting threads.
  - b. The diode threads must be clean and free of defects so that the nut can be finger tightened before applying torque. A "slip" type torque wrench must be used to tighten the diode nut.
6. Tighten the diode nuts to the specifications in the following table.
  - a. The nuts for diodes with steel studs are to be started by hand and then torqued as per the following table.
  - b. The nuts for diodes with copper studs are to run on all the way by hand then torqued as per the following table.
  - c. Turn a minimum of 1/2 turn more while torquing per the table.

DIODE STUD SIZE	FOOT-POUNDS	INCH-POUNDS
3/4 - 16	25-27	300-324
3/8 - 24	10±.5	125+0/-5
1/4 - 28		22-25

PRECISION TIG 375



## POLARITY SWITCH REMOVAL AND REPLACEMENT

### WARNING

Service and repair should be performed by only Lincoln Electric factory trained personnel. Unauthorized repairs performed on this equipment may result in danger to the technician or machine operator and will invalidate your factory warranty. For your safety and to avoid electrical shock, please observe all safety notes and precautions detailed throughout this manual.

If for any reason you do not understand the test procedures or are unable to perform the test/repairs safely, contact the Lincoln Electric Service Department for electrical troubleshooting assistance before you proceed. Call 1-888-935-3877.

---

### DESCRIPTION

This procedure will aid the technician in the removal and replacement of the polarity switch.

### MATERIALS NEEDED

- 3/8" Nut Driver
- 1/2" Wrench
- 7/16" Wrench
- Phillips Head Screw Driver
- Slot Head Screw Driver (2 Required)

PRECISION TIG 275



## POLARITY SWITCH REMOVAL AND REPLACEMENT *(continued)*

Figure F.15 - Switch Location

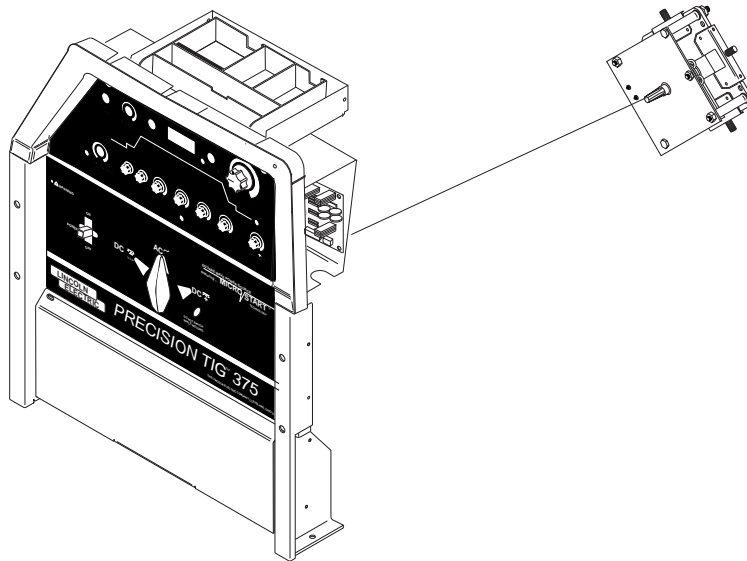

### REMOVAL PROCEDURE

1. Remove the input to the PRECISION TIG 275 machine.
2. Using the 3/8" nut driver, remove the case sides and top.
3. Locate the polarity switch. See Figure F.15.
4. Using a 1/2" wrench label and disconnect leads B,C,252, Pos, Neg, D2 diode assembly,S,253, choke lead, X2 and all leads from the main transformer. Be sure to label leads for reassembly.
5. Disconnect leads 265 and 266A using quick disconnects.
6. Using a phillips head screw driver, remove the screw from the polarity switch handle. See Figure F.15.
7. With the 2 slot head screw drivers, carefully pry the polarity switch handle
8. Carefully peel back the lower nameplate on the case front located around the polarity switch to gain access to the polarity switch mounting nuts.

**NOTE:** Do not remove the sticker completely.

9. Using a 7/16" nut driver remove the two polarity switch mounting nuts located behind the previously removed nameplate.
10. The polarity switch is ready for removal.

### REPLACEMENT PROCEDURE

1. Replace the polarity switch.
2. Secure the polarity switch in its original position with the 7/16" mounting nuts.
3. Firmly press the lower nameplate back into its original position on the case front.
4. Press the polarity switch handle back onto its shaft.
5. Secure polarity switch handle with the phillips head screw previously removed.
6. Reconnect leads 265 and 266A previously removed.
7. Reconnect all previously removed leads to their proper terminals. See Wiring Diagram.
8. Replace case sides and top.

PRECISION TIG 275



## SCR REMOVAL AND REPLACEMENT

### WARNING

Service and repair should be performed by only Lincoln Electric factory trained personnel. Unauthorized repairs performed on this equipment may result in danger to the technician or machine operator and will invalidate your factory warranty. For your safety and to avoid electrical shock, please observe all safety notes and precautions detailed throughout this manual.

If for any reason you do not understand the test procedures or are unable to perform the test/repairs safely, contact the Lincoln Electric Service Department for electrical troubleshooting assistance before you proceed. Call 1-888-935-3877.

---

### DESCRIPTION

The following procedure will aid the technician in removing the SCRs from the output rectifier heat sink for maintenance or replacement.

### MATERIALS NEEDED

No. 000 Fine Steel Wool  
Penetrox A-13 (Lincoln E2529) or Penetrox A  
7/16" Open End Wrench  
Allen Head Type Wrenches

PRECISION TIG 275





## SCR REMOVAL AND REPLACEMENT (continued)

Figure F.16 - SCR DETAILS

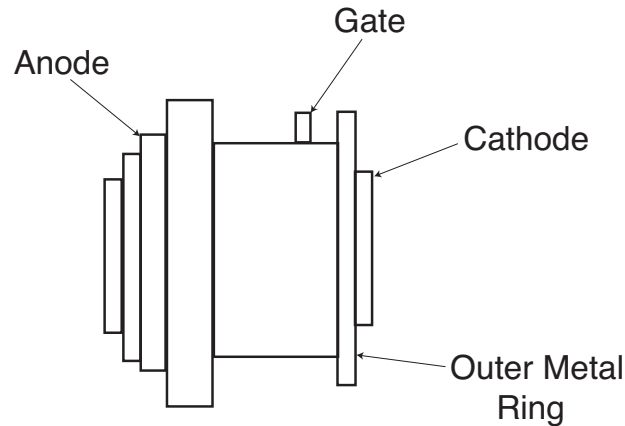

### SPECIAL INSTRUCTIONS

**NOTE:** Before disassembling the existing rectifier, note toward which heat sink the outer metal ring of the power SCR is mounted. Also, note the positioning of the gate lead of the SCR. Failure to reinstall the new SCR in the same orientation as the original may result in subsequent damage to the new SCR and other components of the welder. See Figure F.16.

### ⚠ CAUTION

The unclamping and clamping procedure outlined below is critical for the prevention of internal SCR damage. Failure to follow this procedure may result in subsequent damage of the SCR. Handle all SCRs with care.

### PROCEDURE

1. Remove the main input supply power to the machine.
2. Perform the **SCR/Diode Rectifier Assembly Removal** procedure.
3. Using a 7/16" open end wrench, alternately loosen nuts 1/2 turn each until heat sinks are loose. Remove nuts and leaf spring. IT IS RECOMMENDED THAT NEW HARDWARE, LEAF SPRING AND HOUSING BE USED FOR ASSEMBLY.
4. Remove the old SCR.
5. Clean the area on the heat sink around the SCR mounting surface, using a putty knife or similar tool. DO NOT SCRATCH THE SCR MOUNTING SURFACE.
6. Polish each heat sink's mounting surface using NO.000 fine steel wool. Wipe surface clean with a lint free cloth or paper towel.
7. Inspect the mounting surfaces of each new SCR.
  - a. Remove all burrs and wipe clean. Do not use steel wool or any abrasive cleanser on the SCR mounting surfaces.
8. Apply a thin (0.001" to 0.003") layer of PENETROX A-13 (Lincoln Electric #E2529) or PENTROX A, heat sink compound, to each heat sink's SCR mounting surface.
  - a. Care must be used to prevent foreign material contamination of the SCR to heat sink junction.
9. Place the new SCR between the heat sinks. Be sure that the outer metal ring of the SCR is facing toward the same heat sink as the old SCR's metal ring. Be sure that the roll pin of the heat sink engages the "hole" in the SCR. The SCR contact surfaces must sit flat against both heat sink surfaces.
10. Perform the **SCR/Diode Rectifier Assembly Replacement Procedure**.
11. Replace the case sides and top.

PRECISION TIG 275

**LINCOLN**<sup>®</sup>  
**ELECTRIC**

### RETEST AFTER REPAIR

Should a machine under test be rejected for any reason requiring the removal of any mechanical part that could effect the machine's electrical characteristics, or if any electrical components are required or replaced, the machine must be retested.

INPUT IDLE AMPS		
Input Volts/Hertz	Maximum Idle Amps (without PFC)	Maximum Idle Amps (without PFC)
208/60	6	36
230/60	5	32
460/60	3	16
575/60	2	13

OPEN CIRCUIT VOLTAGES	
MAXIMUM AC OPEN CIRCUIT VOLTAGE	75 VAC
MAXIMUM DC OPEN CIRCUIT VOLTAGE	68 VDC

MAXIMUM ACCEPTABLE OUTPUT VOLTAGE AT MINIMUM OUTPUT SETTINGS	
DC TIG Mode	2 Amps @ 20 Volts

MAXIMUM ACCEPTABLE OUTPUT VOLTAGE AT MAXIMUM OUTPUT SETTINGS	
DC TIG Mode	300 Amps @ 32 Volts

### RECOMMENDED METERS FOR MACHINE OUTPUT TESTS

VOLTMETER: AC and DC True RMS Meter - Fluke 8922A or equivalent  
 AMMETER: Columbia Type AX AC or DC Tong Ammeter

**IMPORTANT: IF OTHER TYPE METERS ARE USED, RESULTS MAY NOT BE ACCURATE.**

PRECISION TIG 275



Return to Section TOC

Return to Section TOC

Return to Section TOC

Return to Section TOC

Return to Master TOC

Return to Master TOC

Return to Master TOC

Return to Master TOC

PRECISION TIG 275



## TABLE OF CONTENTS

### ELECTRICAL DIAGRAMS SECTION

<b>Electrical Diagrams Section .....</b>	<b>Section G</b>
Wiring Diagram (Entire Machine) Code 10806 (G4031) .....	G-2
Wiring Diagram (Entire Machine) Code 10807 (G4031-1) .....	G-3
Wiring Diagram (Entire Machine) Code 10893 (G4031-2) .....	G-4
Wiring Diagram (Entire Machine) Code 11158 (G5692) .....	G-5
Wiring Diagram (Entire Machine) Code 11159 (G5692-1) .....	G-6
Schematic (Entire Machine) Codes below 11000 (G4075) .....	G-7
Schematic (Entire Machine) Codes above 11000 (G5691) .....	G-8
Control P.C. Board Schematic Codes below 11000 (G3908 Page 1) .....	G-9
Control P.C. Board Schematic Codes below 11000 (G3908 Page 2) .....	G-10
Control P.C. Board Schematic Codes below 11000 (G3908 Page 3) .....	G-11
Control P.C. Board Assembly Codes below 11000(G3909-2) .....	G-12
Control P.C. Board Schematic Codes above 11000 (G4762 Page 1) .....	G-13
Control P.C. Board Schematic Codes above 11000 (G4762 Page 2) .....	G-14
Control P.C. Board Schematic Codes above 11000 (G4762 Page 3) .....	G-15
Control P.C. Board Schematic Codes above 11000 (G4762 Page 4) .....	G-16
Control P.C. Board Schematic Codes above 11000 (G4762 Page 5) .....	G-17
Control P.C. Board Assembly Codes above 11000 (G4763-1) .....	G-18
Protection P.C. Board Schematic (M16115) .....	G-19
Protection P.C. Board Assembly (M16062-1) .....	G-20
ByPass / Stabilizer P.C. Board Schematic (S22530-1) (Code 10806 & 10807) .....	G-21
ByPass / Stabilizer P.C. Board Assembly (L10121-1) (Code 10806 & 10807) .....	G-22
ByPass and CE P.C. Board Schematic (S24206) (Code 10893) .....	G-23
ByPass and CE P.C. Board Assembly (L10882-1) (Code 10893) .....	G-24
TIG Option P.C. Board Schematic Codes below 11000 (G4039 Page 1) .....	G-25
TIG Option P.C. Board Schematic Codes below 11000 (G4039 Page 2) .....	G-26
TIG Option P.C. Board Assembly Codes below 11000 (G4040-2) .....	G-27
TIG Option P.C. Board Schematic Codes above 11000 (G4760 Page 1) .....	G-28
TIG Option P.C. Board Schematic Codes above 11000 (G4760 Page 2) .....	G-29
TIG Option P.C. Board Schematic Codes above 11000 (G4760 Page 3) .....	G-30
TIG Option P.C. Board Assembly Codes above 11000 (G4761-1) .....	G-31

WIRING DIAGRAM - ENTIRE MACHINE - CODE 10806 (G4031)

Return to Section TOC

Return to Section TOC

Return to Section TOC

Return to Section TOC

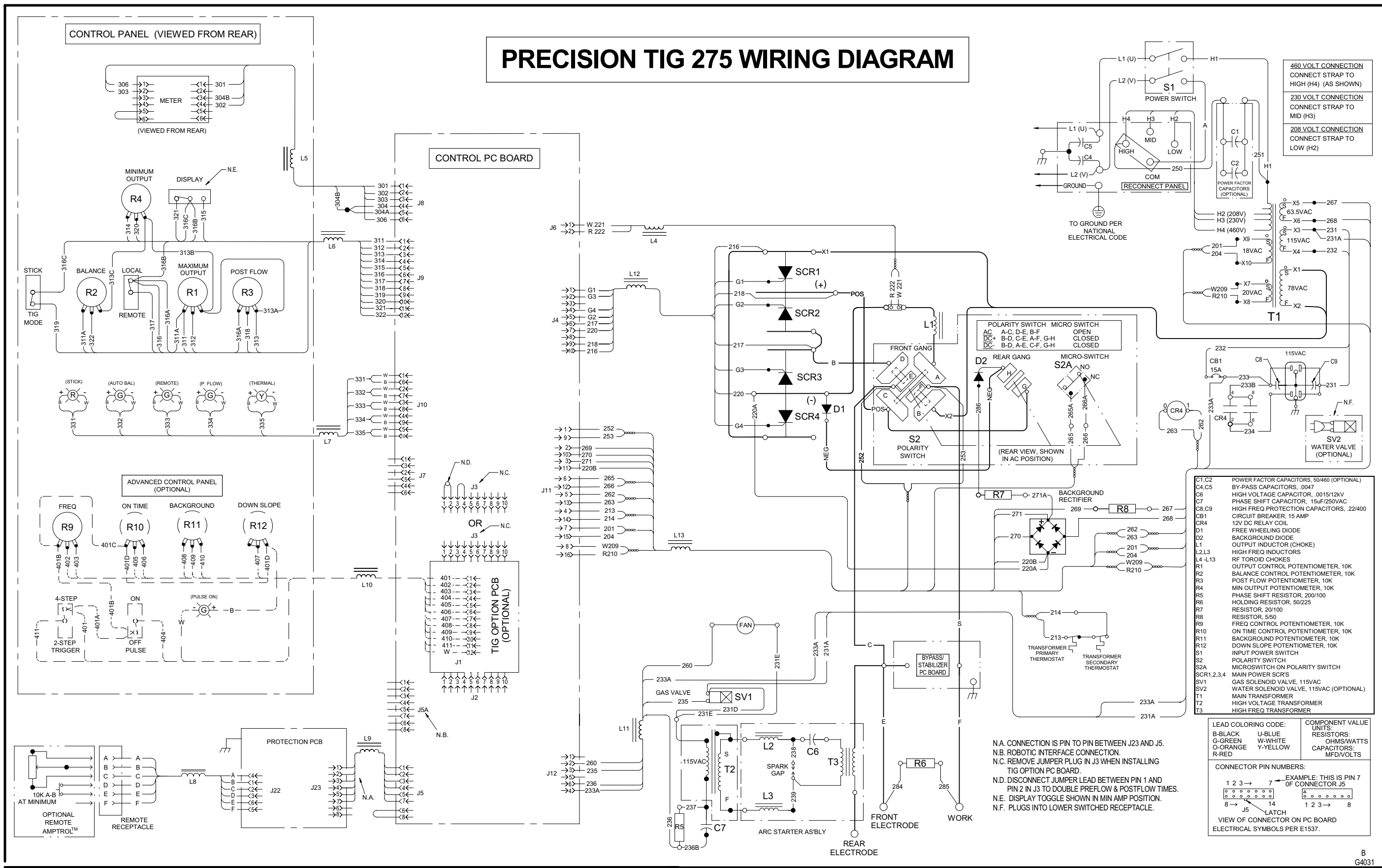

NOTE: This diagram is for reference only. It may not be accurate for all machines covered by this manual. The wiring diagram specific to your code is pasted inside one of the enclosure panels of your machine.







WIRING DIAGRAM - ENTIRE MACHINE - CODE 10893 (G4031-2)

PRECISION TIG 275 WIRING DIAGRAM

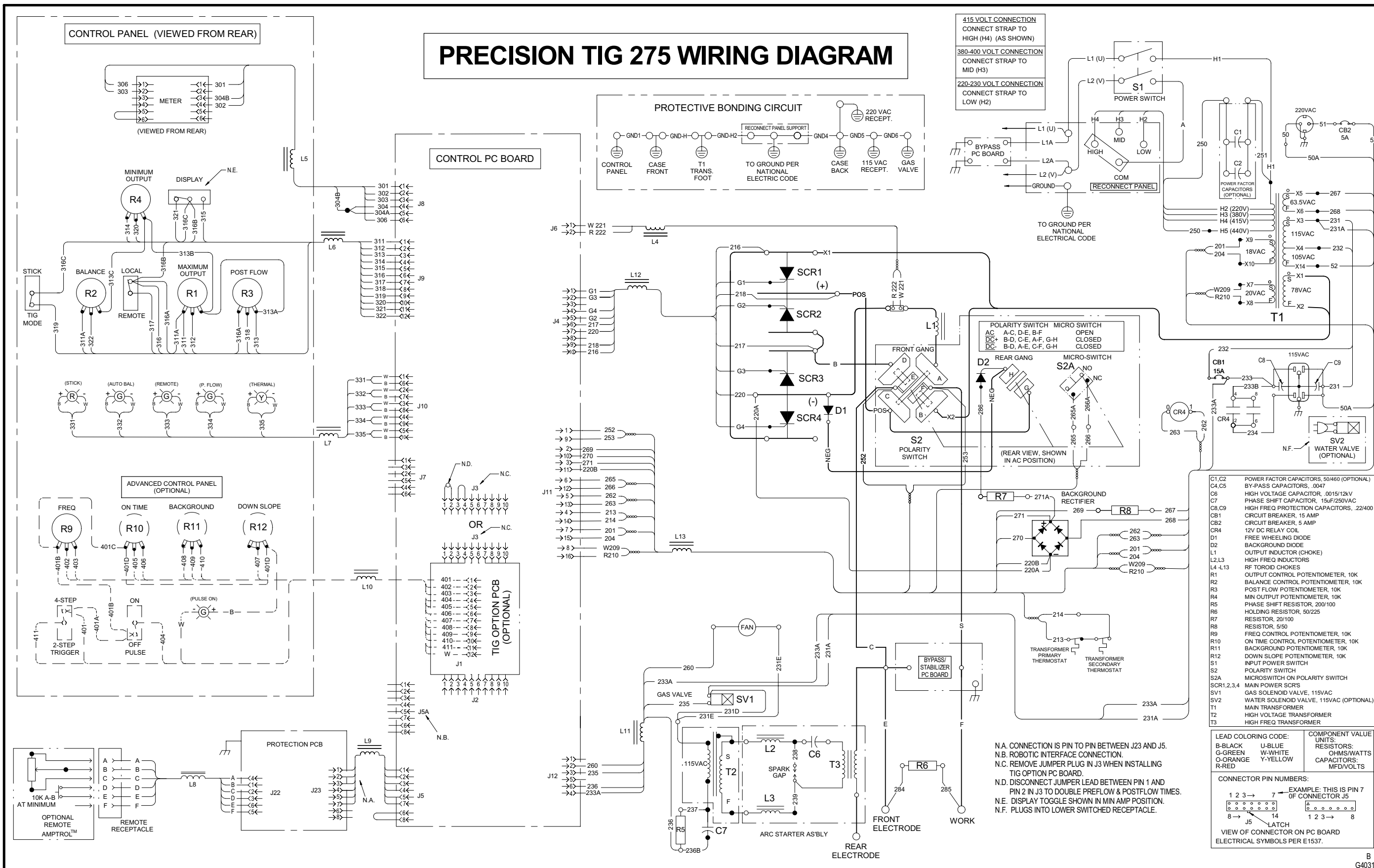

415 VOLT CONNECTION  
CONNECT STRAP TO HIGH (H4) (AS SHOWN)

380-400 VOLT CONNECTION  
CONNECT STRAP TO MID (H3)

220-230 VOLT CONNECTION  
CONNECT STRAP TO LOW (H2)

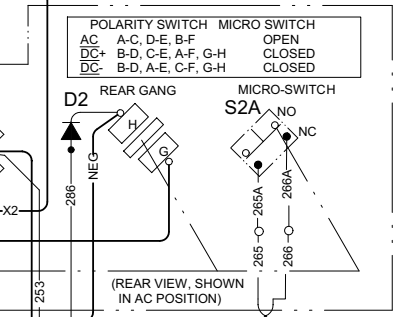
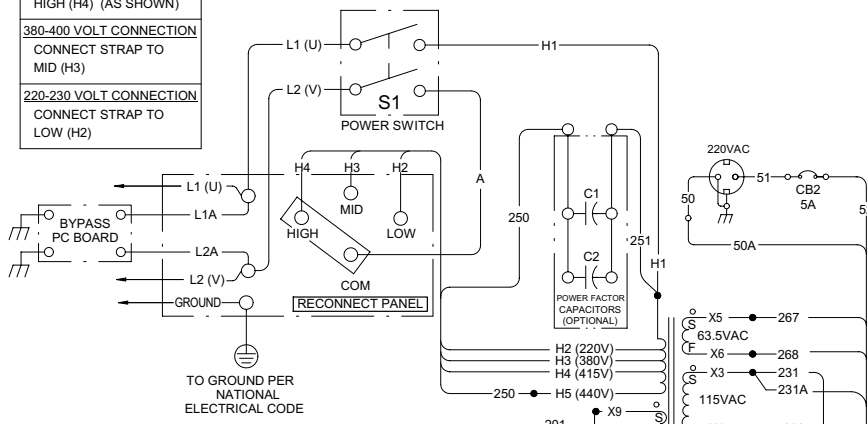
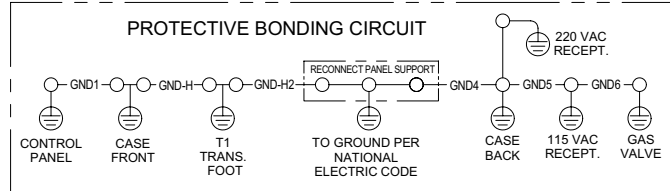

- C1, C2 POWER FACTOR CAPACITORS, 50/460 (OPTIONAL)
- C4, C5 BY-PASS CAPACITORS, .0047
- C6 HIGH VOLTAGE CAPACITOR, .0015/12kV
- C7 PHASE SHIFT CAPACITOR, 15uF/250VAC
- C8, C9 HIGH FREQ PROTECTION CAPACITORS, .22/400
- CB1 CIRCUIT BREAKER, 15 AMP
- CB2 12V DC RELAY COIL
- CR4 FREE WHEELING DIODE
- D1 BACKGROUND DIODE
- D2 BACKGROUND DIODE
- L1 OUTPUT INDUCTOR (CHOKE)
- L2, L3 HIGH FREQ INDUCTORS
- L4 - L13 RF TOROID CHOKES
- R1 OUTPUT CONTROL POTENTIOMETER, 10K
- R2 BALANCE CONTROL POTENTIOMETER, 10K
- R3 POST FLOW POTENTIOMETER, 10K
- R4 MIN OUTPUT POTENTIOMETER, 10K
- R5 PHASE SHIFT RESISTOR, 200/100
- R6 HOLDING RESISTOR, 50/225
- R7 RESISTOR, 20/100
- R8 RESISTOR, 5/50
- R9 FREQ CONTROL POTENTIOMETER, 10K
- R10 ON TIME CONTROL POTENTIOMETER, 10K
- R11 BACKGROUND POTENTIOMETER, 10K
- R12 DOWN SLOPE POTENTIOMETER, 10K
- S1 INPUT POWER SWITCH
- S2 POLARITY SWITCH
- S2A MICROSWITCH ON POLARITY SWITCH
- SCR1, 2, 3, 4 MAIN POWER SCRS
- SV1 GAS SOLENOID VALVE, 115VAC
- SV2 WATER SOLENOID VALVE, 115VAC (OPTIONAL)
- T1 MAIN TRANSFORMER
- T2 HIGH VOLTAGE TRANSFORMER
- T3 HIGH FREQ TRANSFORMER

N.A. CONNECTION IS PIN TO PIN BETWEEN J23 AND J5.  
 N.B. ROBOTIC INTERFACE CONNECTION.  
 N.C. REMOVE JUMPER PLUG IN J3 WHEN INSTALLING TIG OPTION PC BOARD.  
 N.D. DISCONNECT JUMPER LEAD BETWEEN PIN 1 AND PIN 2 IN J3 TO DOUBLE PREFLOW & POSTFLOW TIMES.  
 N.E. DISPLAY TOGGLE SHOWN IN MIN AMP POSITION.  
 N.F. PLUGS INTO LOWER SWITCHED RECEPTACLE.

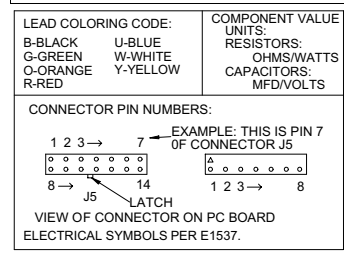

NOTE: This diagram is for reference only. It may not be accurate for all machines covered by this manual. The wiring diagram specific to your code is pasted inside one of the enclosure panels of your machine.



Return to Section TOC

WIRING DIAGRAM - ENTIRE MACHINE - CODE 11158 (G5692)

Return to Section TOC

Return to Section TOC

Return to Section TOC

Return to Section TOC

Return to Master TOC

Return to Master TOC

Return to Master TOC

Return to Master TOC

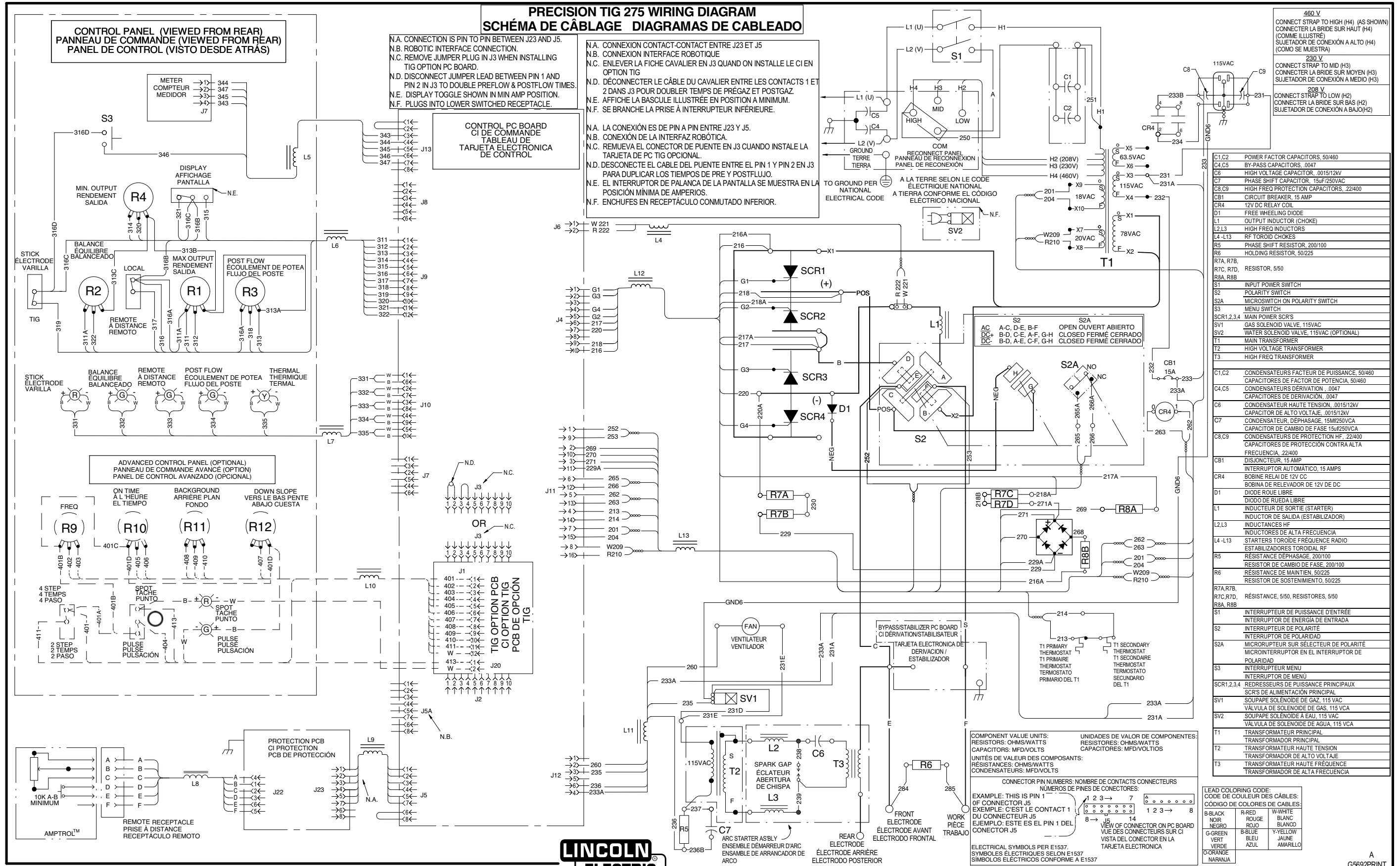

NOTE: This diagram is for reference only. It may not be accurate for all machines covered by this manual. The wiring diagram specific to your code is pasted inside one of the enclosure panels of your machine.





SCHEMATIC - ENTIRE MACHINE - BELOW CODE 11000 (G4075)

Return to Section TOC

Return to Section TOC

Return to Section TOC

Return to Section TOC

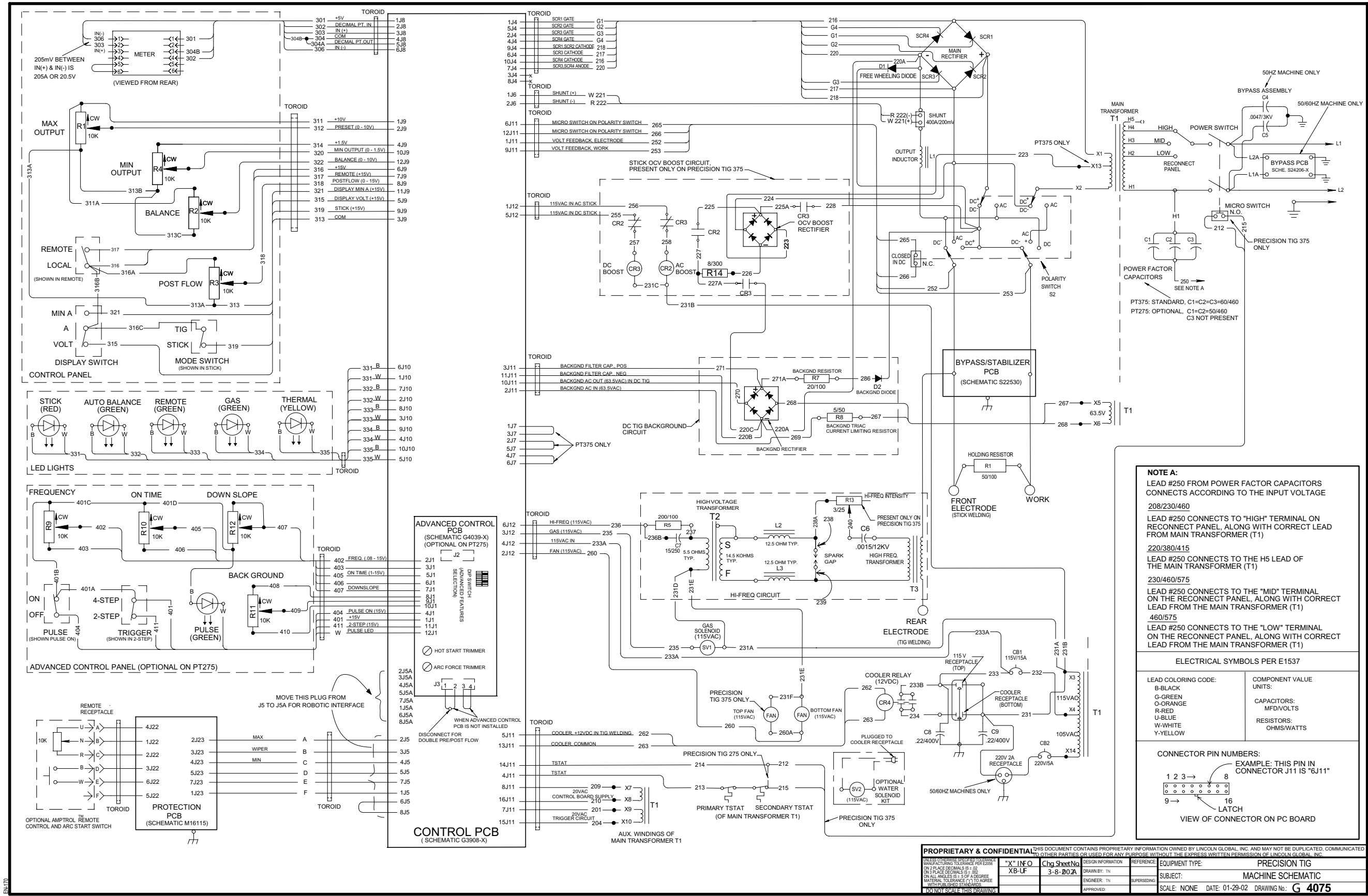

**NOTE A:**  
 LEAD #250 FROM POWER FACTOR CAPACITORS CONNECTS ACCORDING TO THE INPUT VOLTAGE  
 208/230/460  
 LEAD #250 CONNECTS TO "HIGH" TERMINAL ON RECONNECT PANEL, ALONG WITH CORRECT LEAD FROM MAIN TRANSFORMER (T1)  
 220/380/415  
 LEAD #250 CONNECTS TO THE H5 LEAD OF THE MAIN TRANSFORMER (T1)  
 230/460/575  
 LEAD #250 CONNECTS TO THE "MID" TERMINAL ON THE RECONNECT PANEL, ALONG WITH CORRECT LEAD FROM THE MAIN TRANSFORMER (T1)  
 460/575  
 LEAD #250 CONNECTS TO THE "LOW" TERMINAL ON THE RECONNECT PANEL, ALONG WITH CORRECT LEAD FROM THE MAIN TRANSFORMER (T1)

**ELECTRICAL SYMBOLS PER E1537**

LEAD COLORING CODE:	COMPONENT VALUE UNITS:
B-BLACK	CAPACITORS: MFD/VOLTS
G-GREEN	RESISTORS: OHMS/WATTS
O-ORANGE	
R-RED	
U-BLUE	
W-WHITE	
Y-YELLOW	

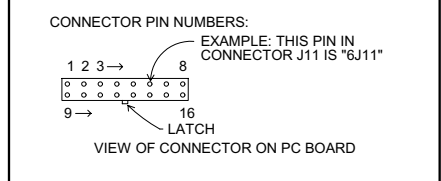

**PROPRIETARY & CONFIDENTIAL** THIS DOCUMENT CONTAINS PROPRIETARY INFORMATION OWNED BY LINCOLN GLOBAL, INC. AND MAY NOT BE DUPLICATED, COMMUNICATED TO OTHER PARTIES OR USED FOR ANY PURPOSE WITHOUT THE EXPRESS WRITTEN PERMISSION OF LINCOLN GLOBAL, INC.

DESIGN INFORMATION	REVISION	EQUIPMENT TYPE:	PRECISION TIG
DATE: 01-29-02	BY: TH	SUBJECT:	MACHINE SCHEMATIC
CHG SHEET NO:	ENGINEER: TH	SCALE:	NONE
3-8-02	APPROVED:	DATE:	01-29-02
		DRAWING NO.:	G 4075

NOTE: This diagram is for reference only. It may not be accurate for all machines covered by this manual.







SCHEMATIC - CONTROL PC BOARD - BELOW CODE 11000 (G3908 PAGE 1)

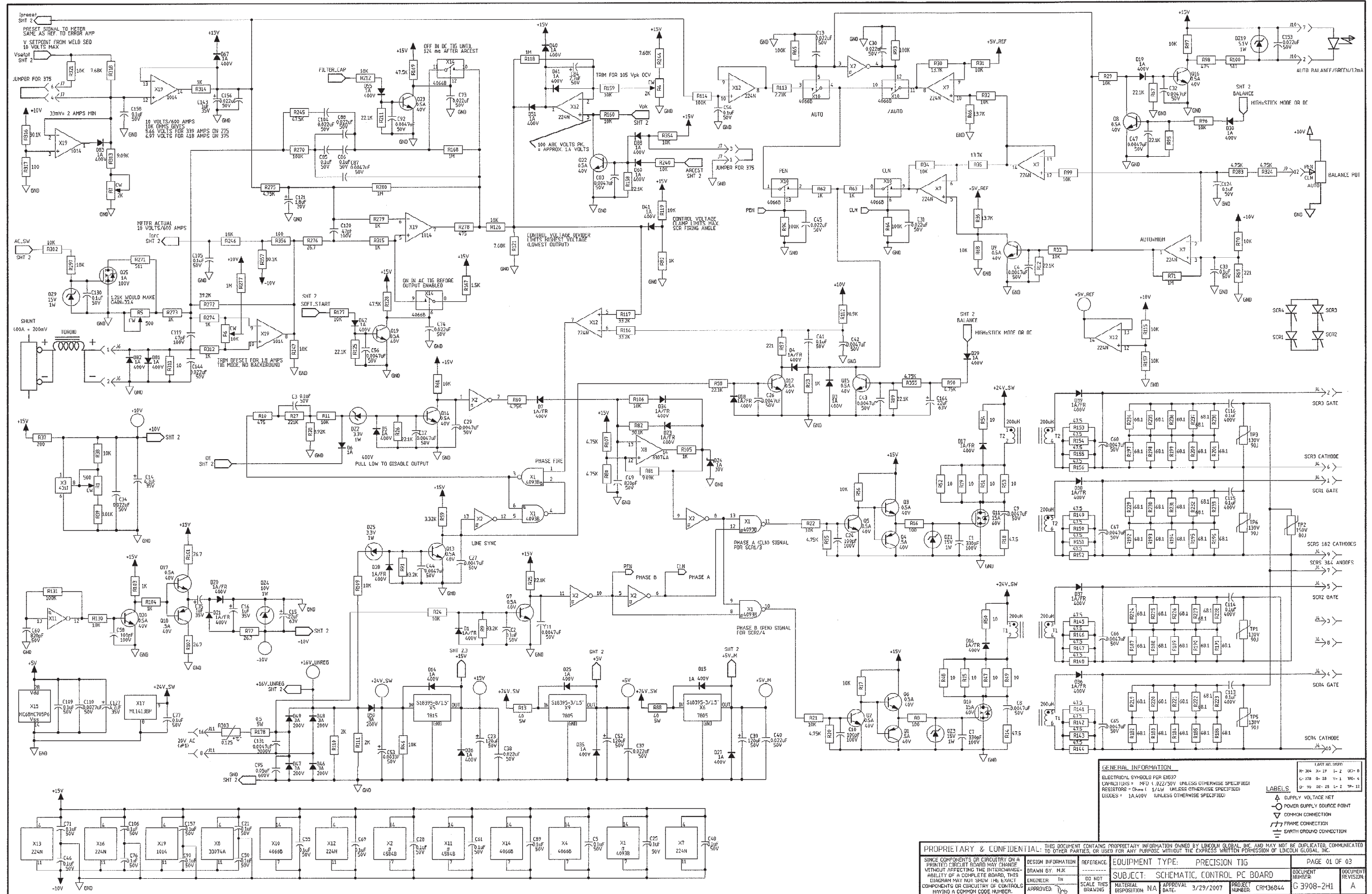

NOTE: This diagram is for reference only. It may not be accurate for all machines covered by this manual.

Return to Section TOC  
Return to Section TOC  
Return to Section TOC  
Return to Section TOC  
Return to Section TOC  
Return to Section TOC

Return to Master TOC  
Return to Master TOC  
Return to Master TOC  
Return to Master TOC  
Return to Master TOC  
Return to Master TOC

PROPRIETARY & CONFIDENTIAL: THIS DOCUMENT CONTAINS PROPRIETARY INFORMATION OWNED BY LINCOLN GLOBAL, INC. AND MAY NOT BE DUPLICATED, COMMUNICATED OR DISCLOSED TO OTHER PARTIES, OR USED FOR ANY PURPOSE WITHOUT THE EXPRESS WRITTEN PERMISSION OF LINCOLN GLOBAL, INC.

DESIGN INFORMATION	DESIGNER: TH	SCALE: THIS DRAWING	APPROVED: [Signature]
EQUIPMENT TYPE: PRECISION TIG	SUBJECT: SCHEMATIC, CONTROL PC BOARD	MATERIAL DISPOSITION: NA	APPROVAL DATE: 3/29/2007
PAGE 01 OF 03	DOCUMENT NUMBER: G 3908-2H1	PROJECT NUMBER: CRM36844	REVISION: A

SCHEMATIC - CONTROL PC BOARD - BELOW CODE 11000 (G3908 PAGE 2)

Return to Section TOC  
Return to Master TOC

Return to Section TOC  
Return to Master TOC

Return to Section TOC  
Return to Master TOC

Return to Section TOC  
Return to Master TOC

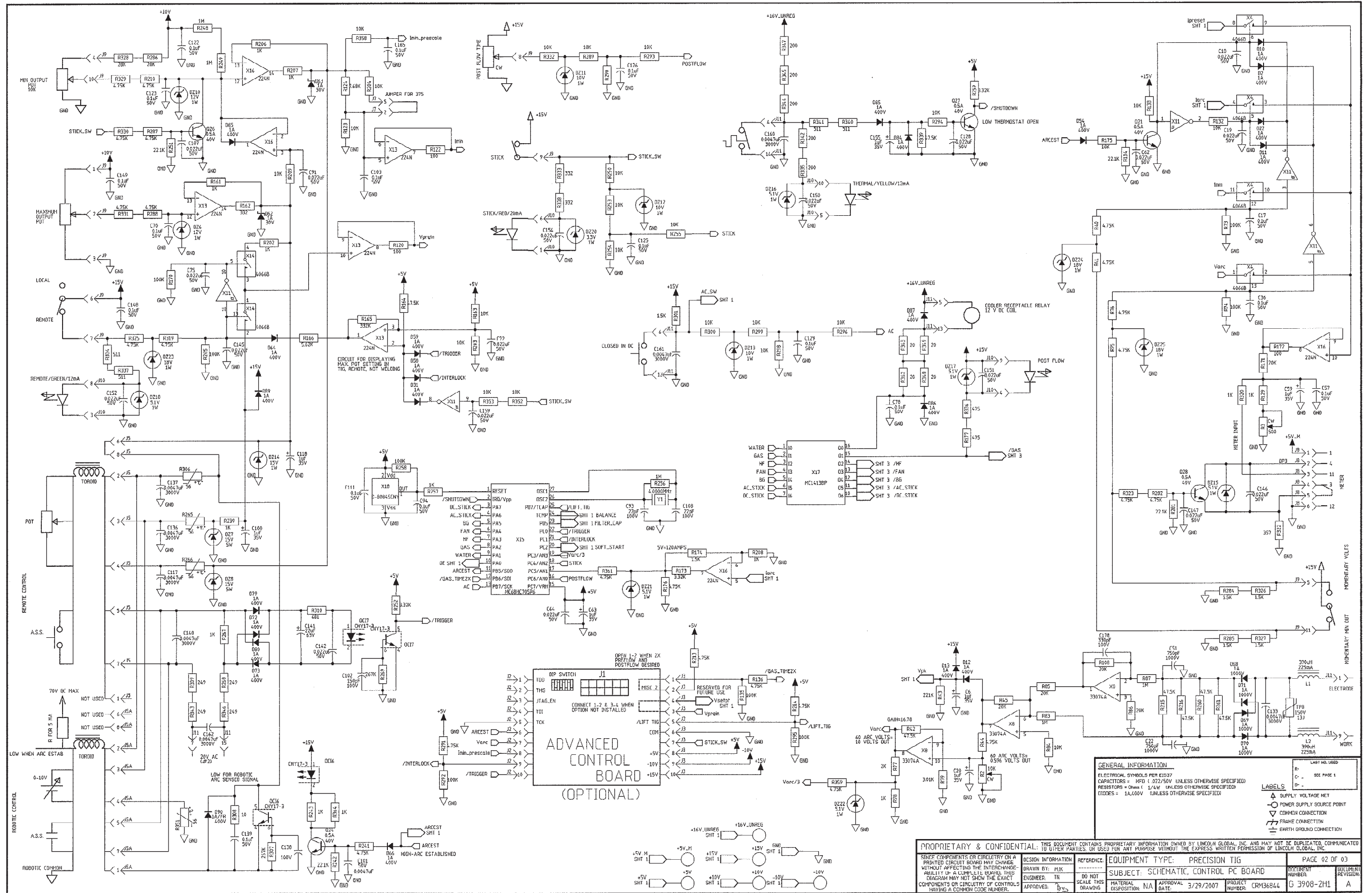

NOTE: This diagram is for reference only. It may not be accurate for all machines covered by this manual.



SCHEMATIC - CONTROL PC BOARD - BELOW CODE 11000 (G3908 PAGE 3)

Return to Section TOC  
Return to Master TOC

Return to Section TOC  
Return to Master TOC

Return to Section TOC  
Return to Master TOC

Return to Section TOC  
Return to Master TOC

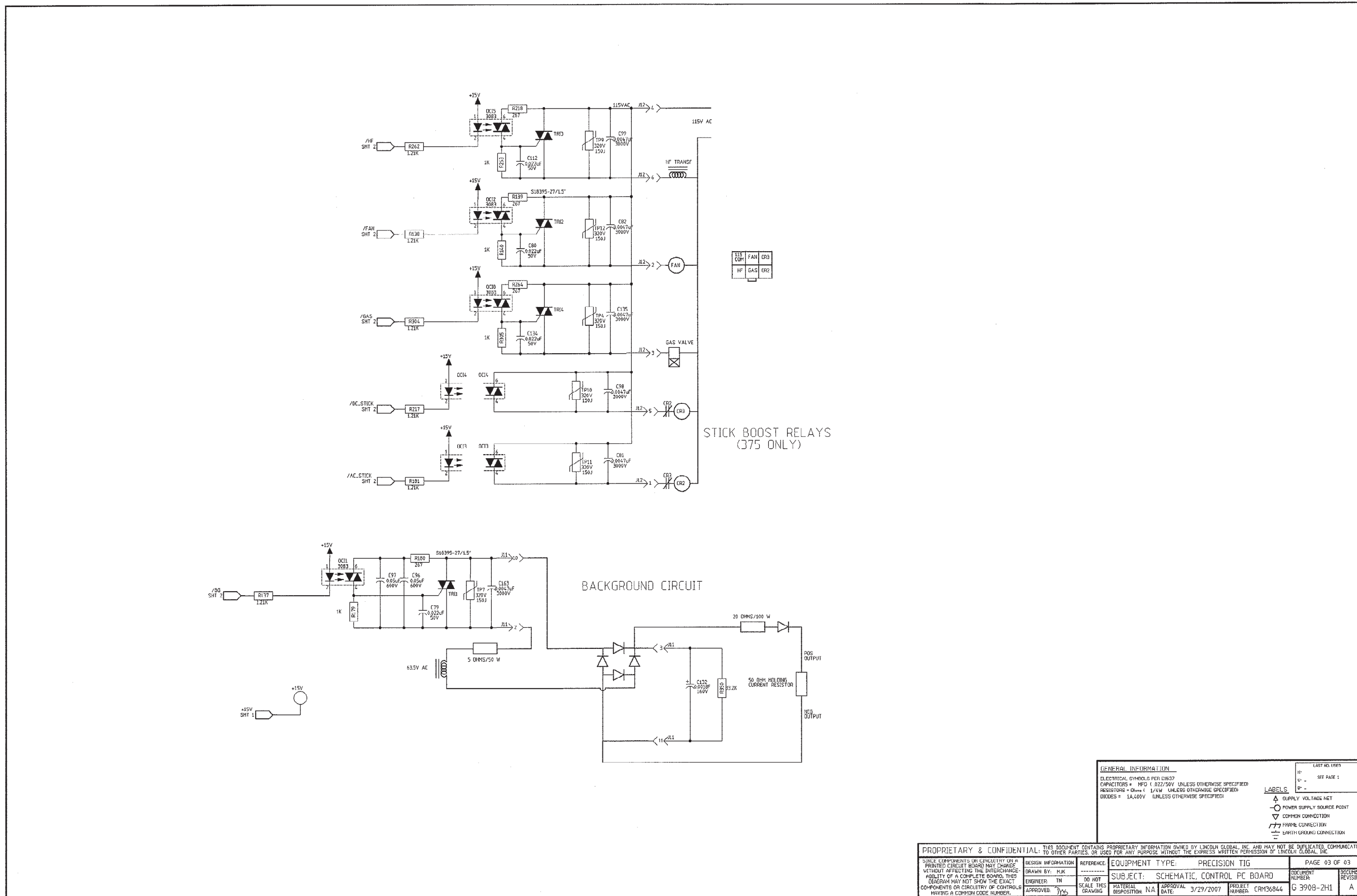

NOTE: This diagram is for reference only. It may not be accurate for all machines covered by this manual.

PROPRIETARY & CONFIDENTIAL: THIS DOCUMENT CONTAINS PROPRIETARY INFORMATION OWNED BY LINCOLN GLOBAL, INC. AND MAY NOT BE DUPLICATED, COMMUNICATED OR USED FOR ANY PURPOSE WITHOUT THE EXPRESS WRITTEN PERMISSION OF LINCOLN GLOBAL, INC.		EQUIPMENT TYPE: PRECISION TIG		PAGE 03 OF 03	
SUBJECT: SCHEMATIC, CONTROL PC BOARD		DOCUMENT NUMBER: G 3908-2H1		DOCUMENT REVISION: A	
DRAWN BY: HJK		ENGINEER: TN		APPROVAL DATE: 3/29/2007	
SCALE THIS DRAWING:		MATERIAL DISPOSITION: NA		PROJECT NUMBER: CRM36844	





SCHEMATIC - CONTROL PC BOARD - ABOVE CODE 11000 (G4762 PAGE 1)

Return to Section TOC  
Return to Master TOC

Return to Section TOC  
Return to Master TOC

Return to Section TOC  
Return to Master TOC

Return to Section TOC  
Return to Master TOC

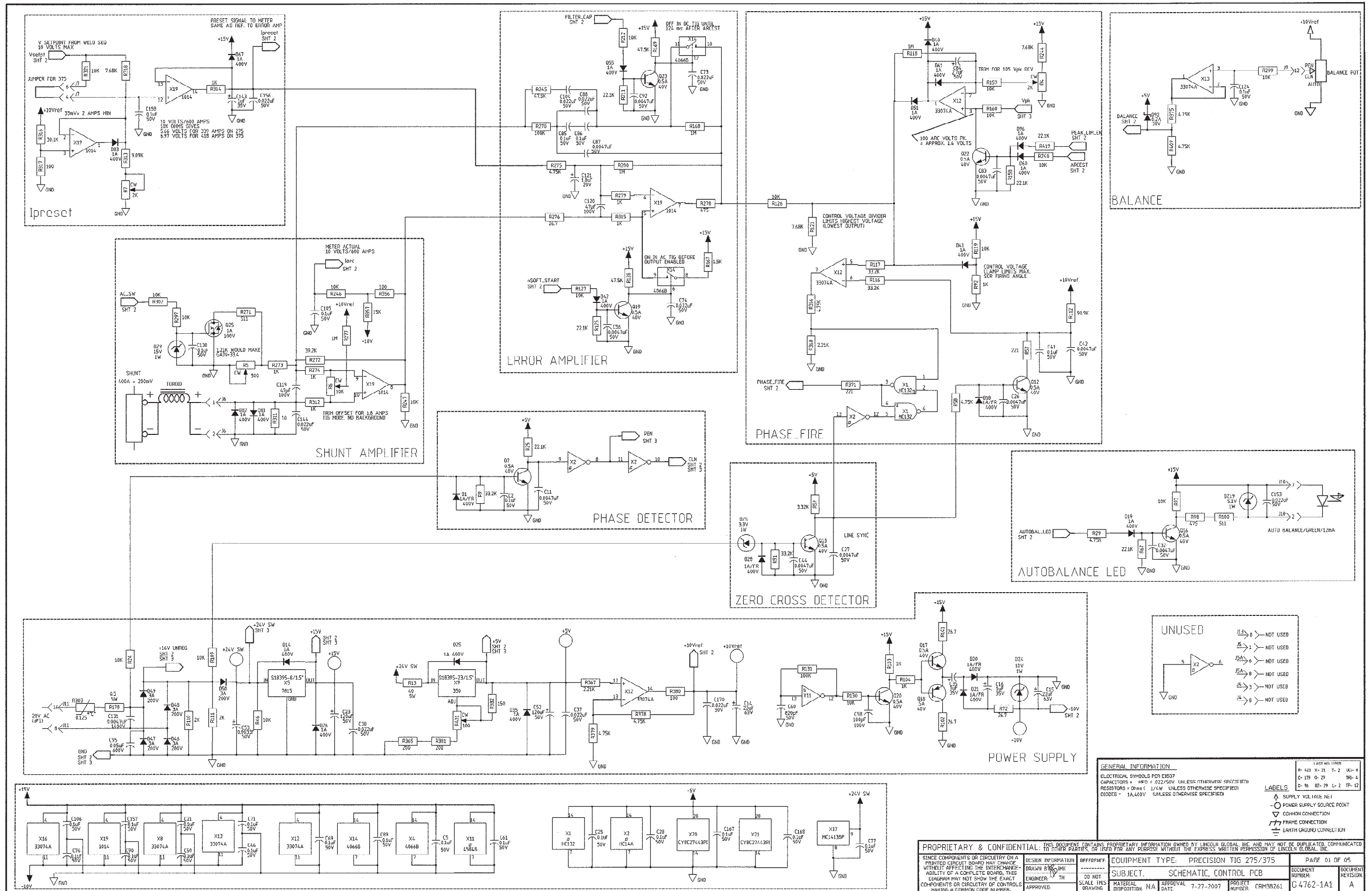

NOTE: This diagram is for reference only. It may not be accurate for all machines covered by this manual.

PROPRIETARY & CONFIDENTIAL - THIS DOCUMENT CONTAINS PROPRIETARY INFORMATION OWNED BY LINCOLN GLOBAL, INC. AND MAY NOT BE DUPLICATED, COMMUNICATED OR DISCLOSED TO OTHER PARTIES, OR USED FOR ANY PURPOSE WITHOUT THE EXPRESS WRITTEN PERMISSION OF LINCOLN GLOBAL, INC.

DESIGN INFORMATION	REFERENCE	EQUIPMENT TYPE: PRECISION TIG 275/375	PAGE 01 OF 05
SUBJECT: SCHEMATIC, CONTROL PCB	DATE: 7-27-2007	PROJECT NUMBER: CRM38261	DOCUMENT NUMBER: G 4762-1A1
APPROVED:	SCALE: THIS DRAWING	REVISION	REVISION



SCHEMATIC - CONTROL PC BOARD - ABOVE CODE 11000 (G4762 PAGE 2)

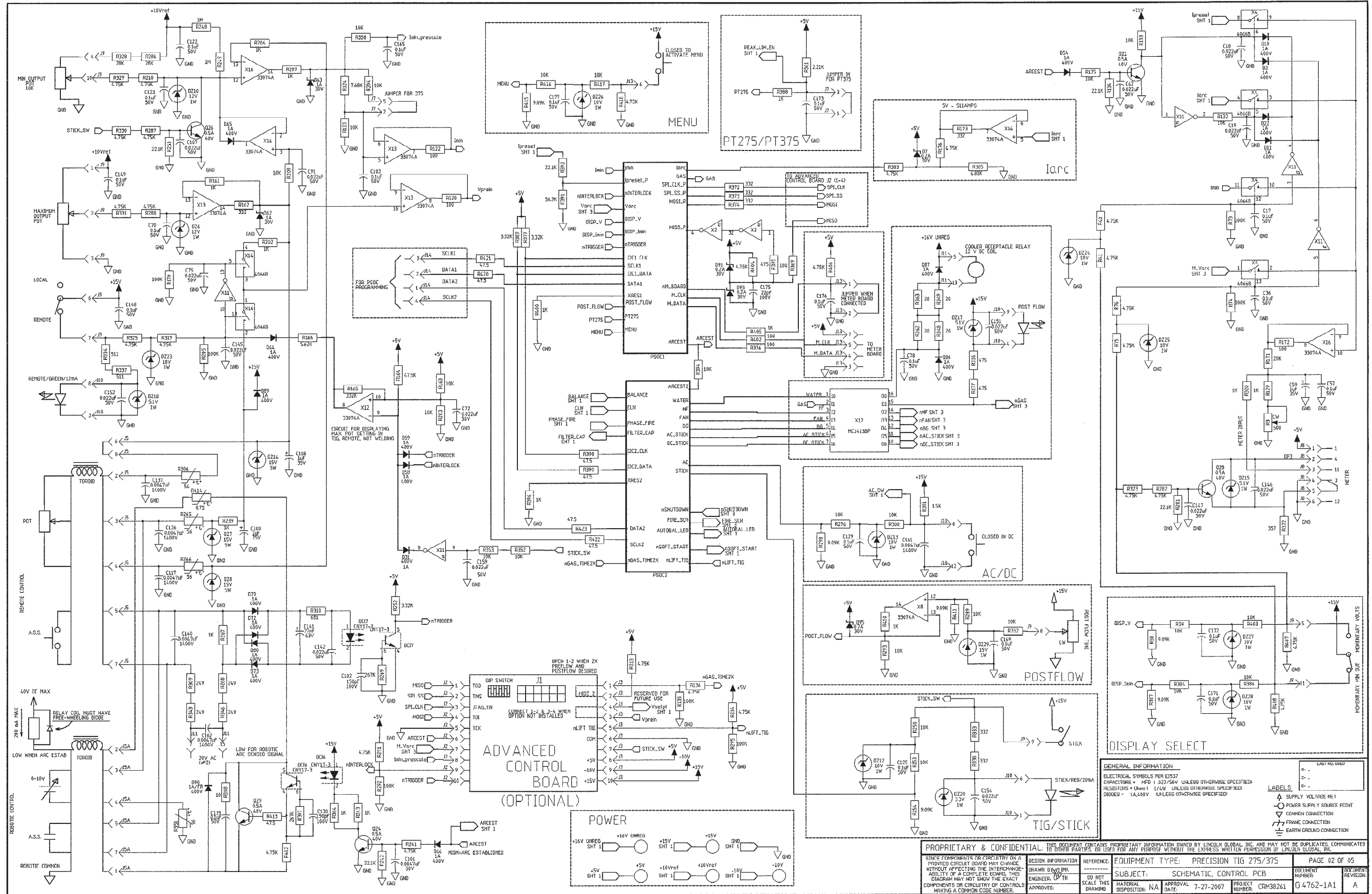

NOTE: This diagram is for reference only. It may not be accurate for all machines covered by this manual.

Return to Section TOC  
Return to Section TOC  
Return to Section TOC  
Return to Section TOC  
Return to Section TOC  
Return to Section TOC  
Return to Section TOC  
Return to Section TOC

PROPRIETARY & CONFIDENTIAL: THE PRESENT DOCUMENT CONTAINS PROPRIETARY INFORMATION OWNED BY LINCOLN GLOBAL, INC. AND MAY NOT BE DUPLICATED, COMMUNICATED TO OTHER PARTIES, OR USED FOR ANY PURPOSE WITHOUT THE EXPRESS WRITTEN PERMISSION OF LINCOLN GLOBAL, INC.

DESIGN INFORMATION	REFERENCE	EQUIPMENT TYPE: PRECISION TIG 275/375	PAGE 02 OF 05
UNAWIT 8/20/06		SUBJECT: SCHEMATIC, CONTROL PCB	DOCUMENT NUMBER: G4762-1A1
ENGINEER: JTH	DO NOT SCALE THIS DRAWING	MATERIAL DISPOSITION: NA	APPROVAL DATE: 7-27-2007
APPROVER:		PROJECT NUMBER: CRM38261	REVISION: A

SCHEMATIC - CONTROL PC BOARD - ABOVE CODE 11000 (G4762 PAGE 3)

Return to Section TOC  
Return to Master TOC

Return to Section TOC  
Return to Master TOC

Return to Section TOC  
Return to Master TOC

Return to Section TOC  
Return to Master TOC

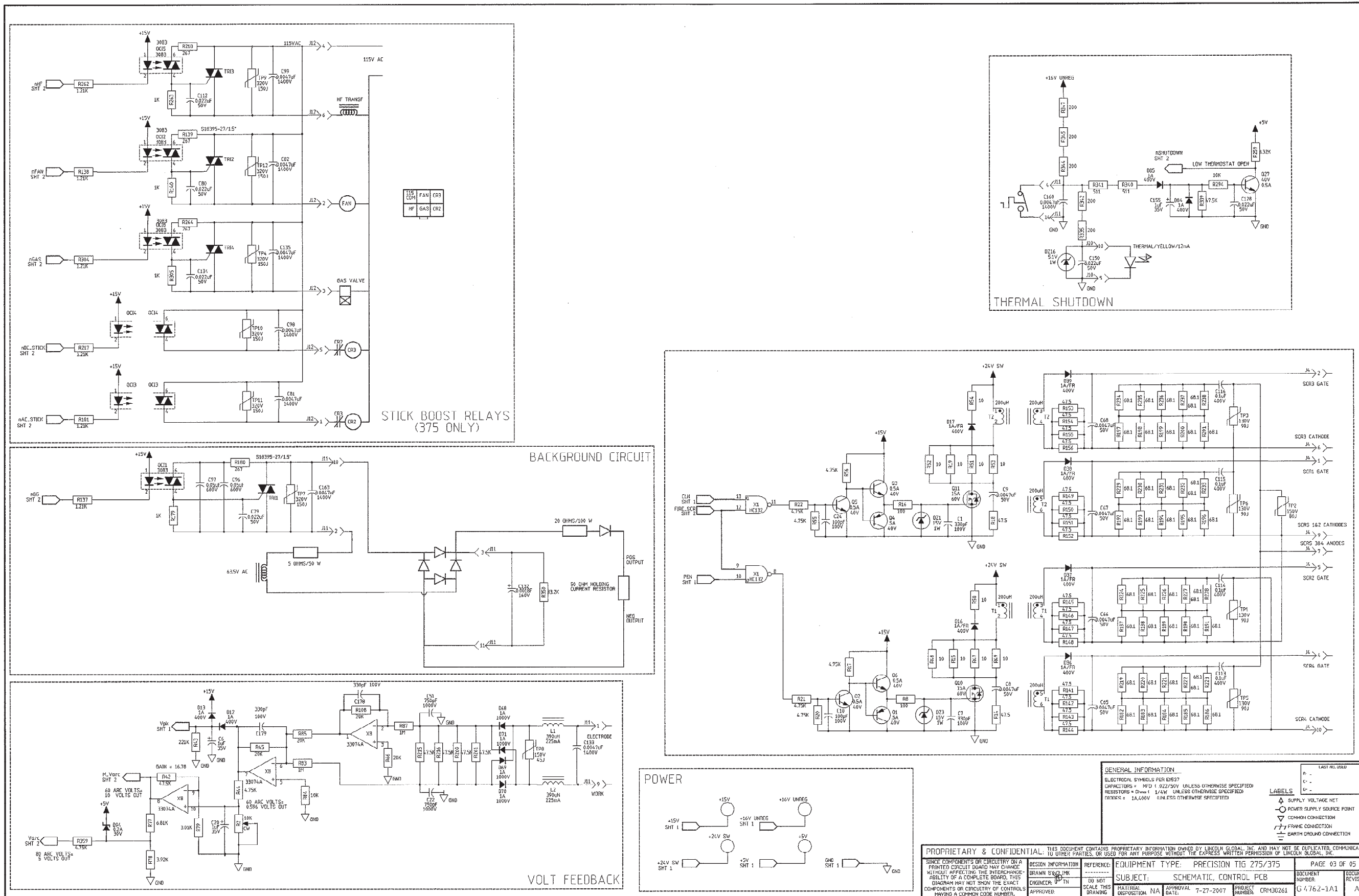

NOTE: This diagram is for reference only. It may not be accurate for all machines covered by this manual.



<b>GENERAL INFORMATION</b> ELECTRICAL SYMBOLS PER IEEE CAPACITORS = MFD 1/22/50V UNLESS OTHERWISE SPECIFIED RESISTORS = OHMS 1/4W UNLESS OTHERWISE SPECIFIED DIMEN = 1A, 100V 6MM UNLESS OTHERWISE SPECIFIED		LAST REV USED R - C - D -
<b>LEGEND</b> ▲ SUPPLY VOLTAGE NET ○ POWER SUPPLY SOURCE POINT ○ COMMON CONNECTION ▽ FRAME CONNECTION ⊕ EARTH GROUND CONNECTION		EQUIPMENT TYPE: PRECISION TIG 275/375 SUBJECT: SCHEMATIC, CONTROL PCB MATERIAL: NA APPROVAL DATE: 7-27-2007 PROJECT NUMBER: CRM30261
<b>PROPRIETARY &amp; CONFIDENTIAL:</b> THIS DOCUMENT CONTAINS PROPRIETARY INFORMATION OWNED BY LINCOLN GLOBAL, INC. AND MAY NOT BE REPRODUCED, COPIED, COMMUNICATED TO OTHER PARTIES, OR USED FOR ANY PURPOSE WITHOUT THE EXPRESS WRITTEN PERMISSION OF LINCOLN GLOBAL, INC. SINCE COMPONENTS OR CIRCUITRY ON A PRINTED CIRCUIT BOARD MAY CHANGE WITHOUT AFFECTING THE INTERCHANGEABILITY OF A COMPLETE BOARD, THIS DIAGRAM MAY NOT SHOW THE EXACT COMPONENTS OR CIRCUITRY OF CONTROLS HAVING A COMMON CODE NUMBER.	<b>DESIGN INFORMATION</b> DRAWN BY: LMK DWG NO: 01 ENGINEER: DTN APPROVED:	PAGE 03 OF 05 DOCUMENT NUMBER: REVISION:

SCHEMATIC - CONTROL PC BOARD - ABOVE CODE 11000 (G4762 PAGE 4)

Return to Section TOC  
Return to Master TOC

Return to Section TOC  
Return to Master TOC

Return to Section TOC  
Return to Master TOC

Return to Section TOC  
Return to Master TOC

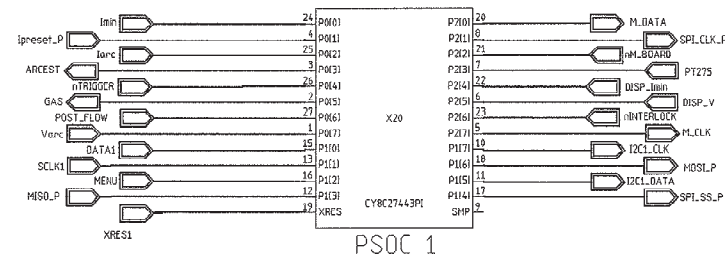

GENERAL INFORMATION		UNIT NO. USED
ELECTRICAL SYMBOLS PER ESD37		R -
CAPACITORS = MFD 1.0/22/50V UNLESS OTHERWISE SPECIFIED		C -
RESISTORS = Ohm 1/4W UNLESS OTHERWISE SPECIFIED		D -
DIODES = 1A, 400V UNLESS OTHERWISE SPECIFIED		
<ul style="list-style-type: none"> <li>△ SUPPLY VOLTAGE NET</li> <li>○ POWER SUPPLY SOURCE POINT</li> <li>▽ COMMON CONNECTION</li> <li>▮ FRAME CONNECTION</li> <li>≡ EARTH GROUND CONNECTION</li> </ul>		

<small>PROPRIETARY &amp; CONFIDENTIAL: THIS DOCUMENT CONTAINS PROPRIETARY INFORMATION OWNED BY LINCOLN GLOBAL, INC. AND MAY NOT BE REPRODUCED, COPIED, OR DISSEMINATED TO OTHER PARTIES, OR USED FOR ANY PURPOSE WITHOUT THE EXPRESS WRITTEN PERMISSION OF LINCOLN GLOBAL, INC.</small>			
DESIGN INFORMATION	REFERENCE	EQUIPMENT TYPE: PRECISION TIG 275/375	PAGE 04 OF 05
DRAWN BY: JHK	DO NOT SCALE THIS DRAWING	SUBJECT: SCHEMATIC CONTROL PCB	DOCUMENT NUMBER: G 4762-1A1
ENGINEER: IN	APPROVED:	MATERIAL DISPOSITION: NA	REVISION: A
		APPROVAL DATE: 7-27-2007	PROJECT NUMBER: CRM38261

NOTE: This diagram is for reference only. It may not be accurate for all machines covered by this manual.



SCHEMATIC - CONTROL PC BOARD - ABOVE CODE 11000 (G4762 PAGE 5)

Return to Section TOC  
Return to Master TOC

Return to Section TOC  
Return to Master TOC

Return to Section TOC  
Return to Master TOC

Return to Section TOC  
Return to Master TOC

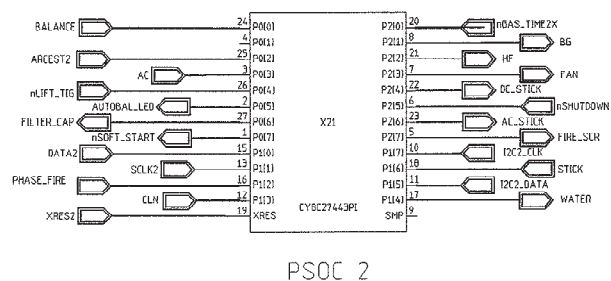

GENERAL INFORMATION		EQUIPMENT TYPE: PRECISION TIG 275/375	
ELECTRICAL SYMBOLS PER IEC 61357		PAGE 05 OF 05	
CAPACITORS = 100 ± 0.22/50V UNLESS OTHERWISE SPECIFIED		DOCUMENT NUMBER: G 4762-1A1	
RESISTORS = 0.5W ± 1% UNLESS OTHERWISE SPECIFIED		DOCUMENT REVISION: A	
DIMENSIONS = 1A, 400V UNLESS OTHERWISE SPECIFIED		PROJECT NUMBER: CRM38261	
Δ SUPPLY VOLTAGE NET ○ POWER SUPPLY SOURCE POINT ▽ COMMON CONNECTION ≡ FRAME CONNECTION ⊕ EARTH GROUND CONNECTION		MATERIAL DISPOSITION: NA APPROVAL DATE: 7-27-2007 SCALE THIS DRAWING:	

PROPRIETARY & CONFIDENTIAL: THIS DOCUMENT CONTAINS PROPRIETARY INFORMATION OWNED BY LINCOLN GLOBAL, INC. AND MAY NOT BE DUPLICATED, COMMUNICATED TO OTHER PARTIES, OR USED FOR ANY PURPOSE WITHOUT THE EXPRESS WRITTEN PERMISSION OF LINCOLN GLOBAL, INC.			
DESIGN INFORMATION	DESIGNER: BJK	APPROVED:	DATE: 7-27-2007
DRAWN BY: BJK	SCALE: THIS DRAWING:	EQUIPMENT TYPE: PRECISION TIG 275/375	PAGE 05 OF 05
ENGINEER: BJK	DO NOT SCALE THIS DRAWING:	SUBJECT: SCHEMATIC, CONTROL PCB	DOCUMENT NUMBER: G 4762-1A1
APPROVED:	DATE: 7-27-2007	MATERIAL DISPOSITION: NA	PROJECT NUMBER: CRM38261

NOTE: This diagram is for reference only. It may not be accurate for all machines covered by this manual.





SCHEMATIC-PROTECTION P.C. BOARD (M16115)

M 16115

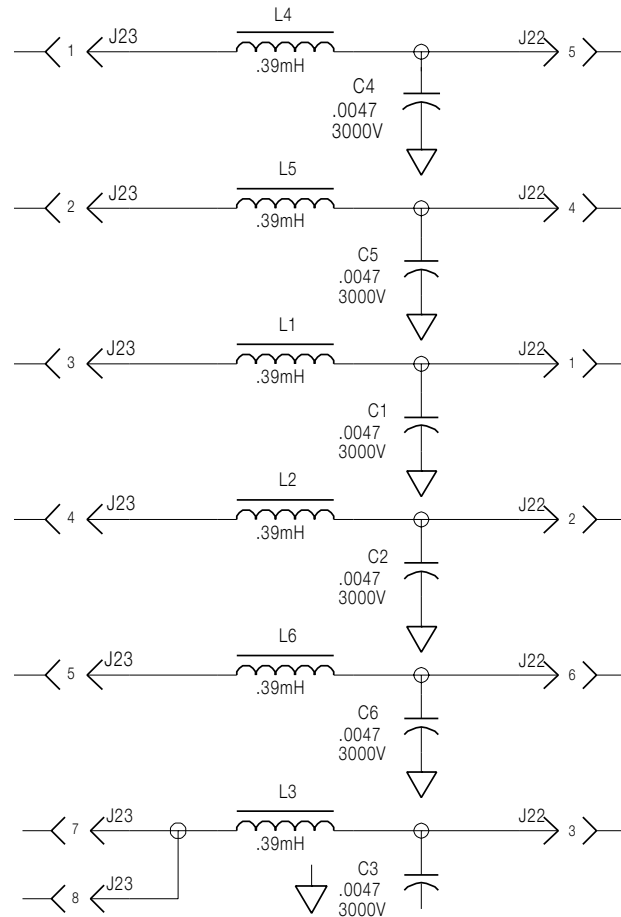

NOTES :

N.A. SINCE COMPONENTS OR CIRCUITRY ON A PRINTED CIRCUIT BOARD MAY CHANGE WITHOUT AFFECTING THE INTERCHANGEABILITY OF A COMPLETE BOARD, THIS DIAGRAM MAY NOT SHOW THE EXACT COMPONENTS OR CIRCUITRY OF CONTROLS HAVING A COMMON CODE NUMBER.

THIS SHEET CONTAINS PROPRIETARY INFORMATION OWNED BY THE LINCOLN ELECTRIC CO. AND IS NOT TO BE REPRODUCED, DISCLOSED OR USED WITHOUT THE EXPRESS PERMISSION OF THE LINCOLN ELECTRIC CO.

UNLESS OTHERWISE SPECIFIED TOLERANCE ON HOLE SIZES PER E2056 ON 2 PLACE DECIMALS IS .02± ON 3 PLACE DECIMALS IS .00± ON ALL ANGLES IS .5° ± A DEGREE MATERIAL TOLERANCE (" ") TO AGREE WITH PUBLISHED STANDARDS.

Chgs. Sht. No.					
5-29-90SPA					

GENERAL INFORMATION		LAST NO. USED	
ELECTRICAL SYMBOLS PER E1537		R- _	
CAPACITORS = MFD (.022/50V UNLESS OTHERWISE SPECIFIED)		C- _	
RESISTORS = Ohms ( 1/4W UNLESS OTHERWISE SPECIFIED)		D- _	
DIODES = 1A, 400V (UNLESS OTHERWISE SPECIFIED)			
EQUIP. TYPE <u>SQARE WAVE TIG 350</u>		SUBJECT <u>PROTECTION P.C. BOARD SCHEMATIC</u>	
SCALE <u>NONE</u>		SHT. NO. <b>M</b> 16115	
DR MK/DRS	DATE 1-12-90	CHK GM/BS	REF. _____ SUP'S'D'G _____

- LABELS
- ▲ SUPPLY VOLTAGE NET
  - POWER SUPPLY SOURCE POINT
  - ▽ COMMON CONNECTION
  - ⎓ FRAME CONNECTION
  - ⊥ EARTH GROUND CONNECTION

NOTE: Lincoln Electric assumes no responsibility for liabilities resulting from board level troubleshooting. PC Board repairs will invalidate your factory warranty. **Individual Printed Circuit Board Components are not available from Lincoln Electric.** This information is provided for reference only. Lincoln Electric discourages board level troubleshooting and repair since it may compromise the quality of the design and may result in danger to the Machine Operator or Technician. Improper PC board repairs could result in damage to the machine.



Return to Section TOC  
Return to Master TOC  
Return to Section TOC  
Return to Master TOC  
Return to Section TOC  
Return to Master TOC  
Return to Section TOC  
Return to Master TOC

PC BOARD ASSEMBLY-PROTECTION (M16062-1)

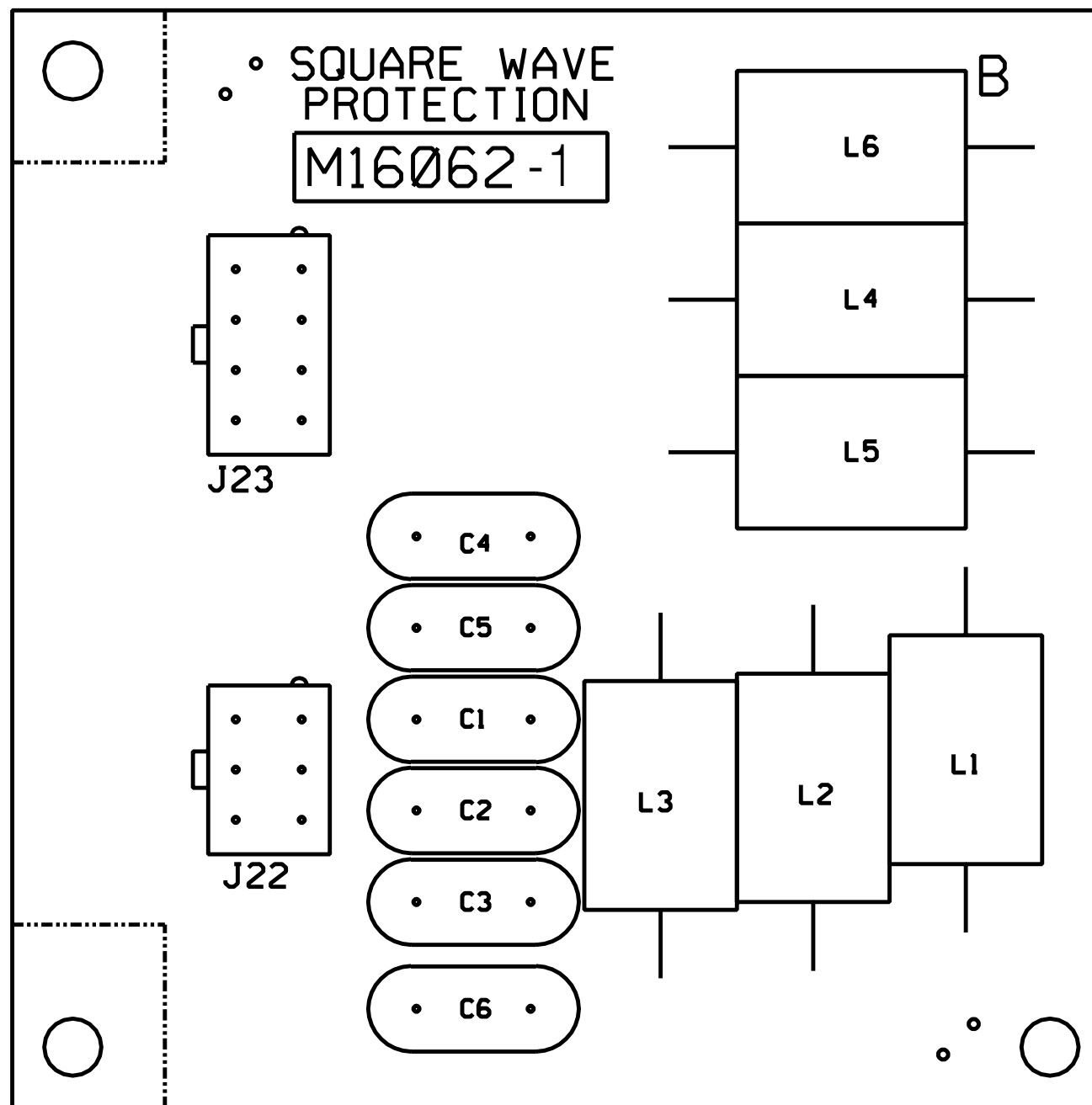

ITEM	REQ'D	PART NO.	IDENTIFICATION
C1, C2, C3, C4, C5, C6	6	T11577-58	.0047/3000 V
L1, L2, L3, L4, L5, L6	6	T12218-9F	.39 mH
J22	1	S18248-6	HEADER
J23	1	S18248-8	HEADER
1	1	L8081-B	P.C. BD BLANK

**M16062-1**  
9-28-2001M

CAPACITORS = MFD/VOLTS

**NOTE:** Lincoln Electric assumes no responsibility for liabilities resulting from board level troubleshooting. PC Board repairs will invalidate your factory warranty. **Individual Printed Circuit Board Components are not available from Lincoln Electric.** This information is provided for reference only. Lincoln Electric discourages board level troubleshooting and repair since it may compromise the quality of the design and may result in danger to the Machine Operator or Technician. Improper PC board repairs could result in damage to the machine.

SCHEMATIC-BYPASS / STABILIZER P.C. BOARD (S22530-1) (CODE 10806 & 10807)

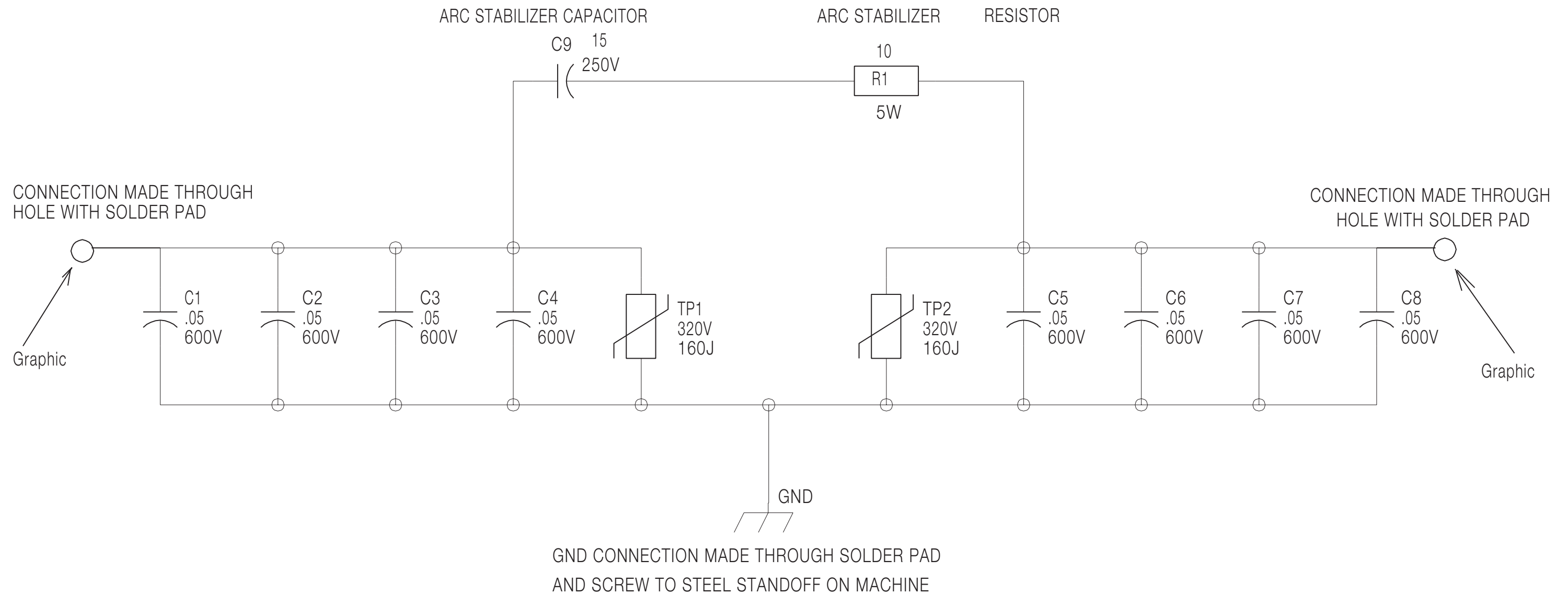

S22530-1B0  
Rev A

NOTES :

N.A. SINCE COMPONENTS OR CIRCUITRY ON A PRINTED CIRCUIT BOARD MAY CHANGE WITHOUT AFFECTING THE INTERCHANGEABILITY OF A COMPLETE BOARD. THIS DIAGRAM MAY NOT SHOW THE EXACT COMPONENTS OR CIRCUITRY OF CONTROLS HAVING A COMMON CODE NUMBER.

GENERAL INFORMATION

ELECTRICAL SYMBOLS PER E1537  
CAPACITORS = MFD ( .022/50V UNLESS OTHERWISE SPECIFIED)  
RESISTORS = Ohms ( 1/4W UNLESS OTHERWISE SPECIFIED)  
DIODES = 1A, 400V (UNLESS OTHERWISE SPECIFIED)

LABELS

- SUPPLY VOLTAGE NET
- POWER SUPPLY SOURCE POINT
- COMMON CONNECTION
- FRAME CONNECTION
- EARTH GROUND CONNECTION

NOTE: This diagram is for reference only. It may not be accurate for all machines covered by this manual.

Return to Section TOC  
Return to Master TOC  
Return to Section TOC  
Return to Master TOC  
Return to Section TOC  
Return to Master TOC  
Return to Section TOC  
Return to Master TOC







PC BOARD ASSEMBLY-BYPASS AND CE (L10882-1) (CODE 10893)

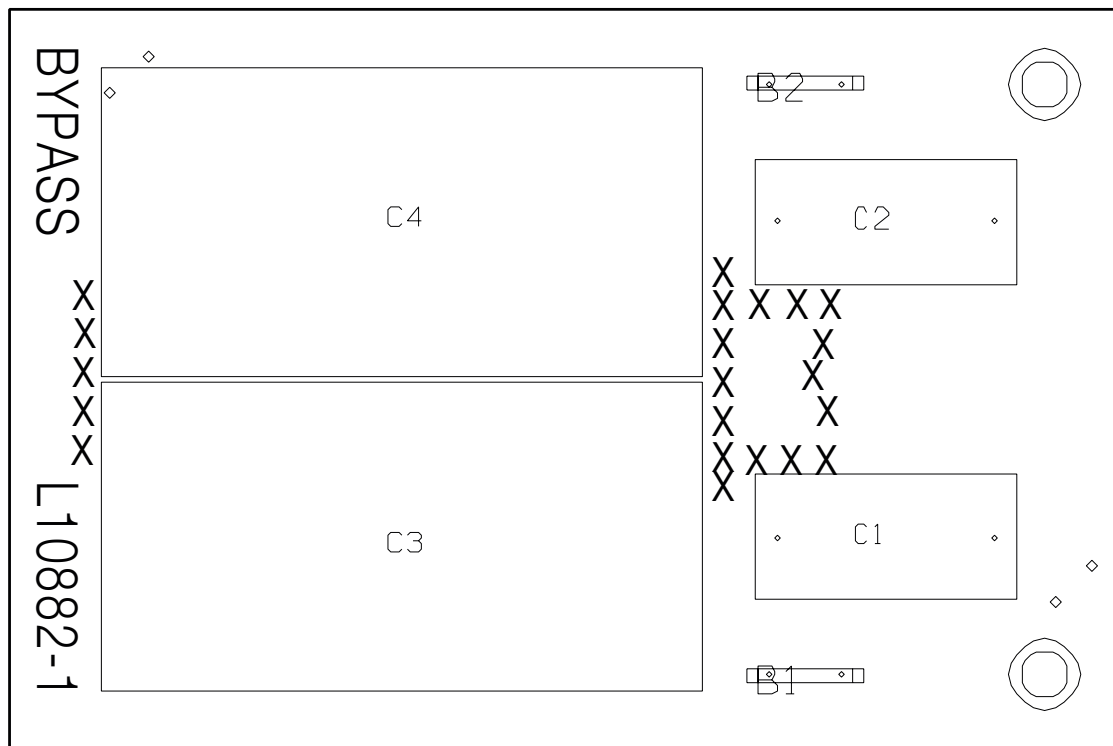

ITEM	REQ'D	PART NO.	IDENTIFICATION
B 1, B2	2	T 13157- 14	TAB TERMINAL
C 1, C2	2	S23020- 3	CAPACITOR, PM, . 0047, 440VAC
C3, C4	2	S23020-2	CAPACITOR, PEMF, 2. 2, 275VAC

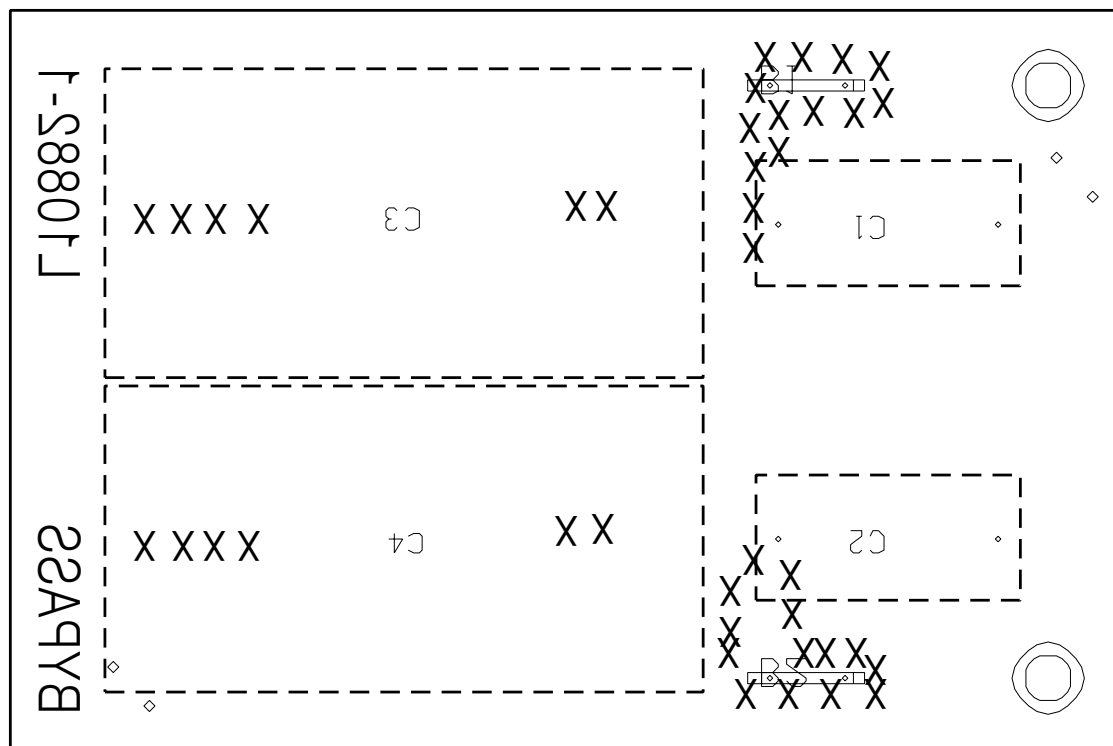

BOTTOM VIEW

L 10882-1  
3-20-98

**NOTE:** Lincoln Electric assumes no responsibility for liabilities resulting from board level troubleshooting. PC Board repairs will invalidate your factory warranty. **Individual Printed Circuit Board Components are not available from Lincoln Electric.** This information is provided for reference only. Lincoln Electric discourages board level troubleshooting and repair since it may compromise the quality of the design and may result in danger to the Machine Operator or Technician. Improper PC board repairs could result in damage to the machine.





PC BOARD ASSEMBLY - TIG OPTION P.C. BOARD - BELOW CODE 11000 (G4040-2)

Return to Section TOC  
Return to Master TOC

Return to Section TOC  
Return to Master TOC

Return to Section TOC  
Return to Master TOC

Return to Section TOC  
Return to Master TOC

<b>G4040-2</b>	ENGINEERING CONTROLLED MANUFACTURER: Yes	CHANGE DETAIL: REVISED MANUFACTURER SPECIFICATION	
----------------	---	---	--

**REVISION CONTROL**

**G4040-2F0**

PART NO. IDENTIFICATION CODE

TEST PER E3837-AC  
COAT WITH E1844 AND E3668 (1 COAT EACH)

SCHEMATIC REFERENCE: G4039-2F0

<b>BUY DETAIL</b> BUY PER E3867	<b>MAKE DETAIL</b> MANUFACTURE PER E1911-ROHS BUY BLANK COMPLETE (6 BOARDS PER PANEL)
------------------------------------	--

4 LAYER BOARD BLANK PANEL  
SEE ELECTRONIC FILE FOR ADDITIONAL INFORMATION

ITEM	QTY	PART NUMBER	DESCRIPTION
1	1	G4040-F	PC BOARD BLANK
2	1	S25409-1	SOFTWARE CPLD (X3)
REFER TO ELECTRONIC COMPONENT DATABASE FOR SPECIFICATIONS ON ITEMS LISTED BELOW			
REFERENCES	QTY	PART NUMBER	DESCRIPTION
C1, C2, C4, C5, C7, C9, C10, C14, C15, C16, C17, C18, C19, C21, C22, C23, C24, C26, C27, C28, C29, C30, C31, C32, C33, C34, C38, C39, C40, C41, C42, C43, C44, C45, C47, C49, C50, C51, C52, C53, C54, C55, C56, C57	44	S25020-35SMT	CAPACITOR, SMD, CERAMIC, 0.1MF, 50V, 10%, XTR, S0805
C3, C8, C58	3	S25020-25SMT	CAPACITOR, SMD, CERAMIC, 0.022MF, 50V, 10%, XTR, S0805
C8, C20	2	S25020-45SMT	CAPACITOR, SMD, CERAMIC, 2700PF, 50V, 5%, XTR, S0805
C11, C12, C13, C35, C36, C37, C46, C48	8	S25020-24SMT	CAPACITOR, SMD, CERAMIC, 1.0MF, 25V, 10%, XTR, S1206
C59	1	S25020-12SMT	CAPACITOR, SMD, CERAMIC, 100PF, 100V, 5%, COG, S0805
D1	1	S25040-25SMT	DIODE, SMD, 1A, 400V, DO-214BA/AC
D2, D3, D8, D10	4	S25049-45SMT	DIODE, SMD, SCHOTTKY, DUAL, 0.200A, 30V, SOT-23
D4, D5, D6, D7, D9	5	S25040-55SMT	DIODE, SMD, DUAL, 0.200A, 70V, UFR
DZ1	1	S25046-15SMT	ZENER DIODE, SMD, 0.5W, 5.1V, 5%, SOD123
DZ2, DZ3	2	S25046-45SMT	ZENER DIODE, SMD, 0.5W, 12V, 5%, SOD-123
N.D. J1	1	S25020-12	CONNECTOR, MOLEX, MINI, PCB, 12-PIN, TIN
N.D. J2, J3	2	S21135-10	CONNECTOR, MOLEX, MINI, BLIND, F, 10-PIN
LED1, LED2	2	S25080-25SMT	LED, SMD, GREEN, CLEAR, S1206
Q1, Q5	2	S25051-45SMT	TRANSISTOR, SMD, NMF, SOT-23, 0.115A, 60V, 7002LT1(SS)
Q2, Q3, Q4, Q6, Q7	5	S25050-15SMT	TRANSISTOR, SMD, NPN, 0.5A, 40V, SOT-23, MMBT4401LT1
R1, R13, R26, R66, R87, R93, R105, R126, R163, R164, R165, R166, R167	13	S25000-4751SMT	RESISTOR, SMD, METAL, FILM, 1/10W, 4.75K, 1%, S0805
R2, R3, R4, R5, R8, R12, R43, R47, R48, R88, R90, R108, R109, R112, R122, R145, R146, R147, R160	19	S25000-1001SMT	RESISTOR, SMD, METAL, FILM, 1/10W, 1.00K, 1%, S0805
R6, R10, R14, R16, R17, R18, R21, R28, R29, R32, R33, R48, R52, R53, R56, R61, R63, R64, R65, R89, R92, R101, R102, R103, R104, R107, R116, R120, R123, R128, R130, R135, R137, R138, R139, R140, R141, R143, R151, R152, R153, R154, R155, R157	44	S25000-1002SMT	RESISTOR, SMD, METAL, FILM, 1/10W, 10.0K, 1%, S0805
R7	1	S25058-15SMT	TRIMMER, SMD, ST, 1/4W, 10K, 10%, LINEAR
R9, R34, R37, R38, R50, R67, R127, R131, R132, R133	10	S25000-5110SMT	RESISTOR, SMD, METAL, FILM, 1/10W, 510OHMS, 1%, S0805
R11, R42, R49, R51, R111, R134, R161, R162	8	S25000-4750SMT	RESISTOR, SMD, METAL, FILM, 1/10W, 475OHMS, 1%, S0805
R15, R79, R81	3	S25000-1372SMT	RESISTOR, SMD, METAL, FILM, 1/10W, 13.7K, 1%, S0805
R19, R57	2	S25000-10R0SMT	RESISTOR, SMD, METAL, FILM, 1/10W, 10.0OHMS, 1%, S0805
R20	1	S25000-1501SMT	RESISTOR, SMD, METAL, FILM, 1/10W, 1.50K, 1%, S0805
R22, R142, R144	3	S25000-2212SMT	RESISTOR, SMD, METAL, FILM, 1/10W, 22.1K, 1%, S0805
R23, R62, R86, R136, R158	5	S25000-2002SMT	RESISTOR, SMD, METAL, FILM, 1/10W, 20.0K, 1%, S0805
R24, R44, R91, R110, R121	5	S25000-1211SMT	RESISTOR, SMD, METAL, FILM, 1/10W, 1.21K, 1%, S0805
R25	1	S25000-2211SMT	RESISTOR, SMD, METAL, FILM, 1/10W, 2.21K, 1%, S0805
R27, R46, R75	3	S25000-3323SMT	RESISTOR, SMD, METAL, FILM, 1/10W, 332K, 1%, S0805
R30, R31, R168	3	S25000-4752SMT	RESISTOR, SMD, METAL, FILM, 1/10W, 47.5K, 1%, S0805
R35, R36, R106, R124	4	S25000-3320SMT	RESISTOR, SMD, METAL, FILM, 1/10W, 332OHMS, 1%, S0805
R39	1	S25000-4753SMT	RESISTOR, SMD, METAL, FILM, 1/10W, 47.5K, 1%, S0805
R40, R45	2	S25000-1000SMT	RESISTOR, SMD, METAL, FILM, 1/10W, 100OHMS, 1%, S0805
R41	1	S25000-47R5SMT	RESISTOR, SMD, METAL, FILM, 1/10W, 47.5OHMS, 1%, S0805
R54, R69, R77	3	S25000-3323SMT	RESISTOR, SMD, METAL, FILM, 1/10W, 3.32K, 1%, S0805
R55, R82, R125	3	S25000-1821SMT	RESISTOR, SMD, METAL, FILM, 1/10W, 1.82K, 1%, S0805
R58, R84	2	S25000-6811SMT	RESISTOR, SMD, METAL, FILM, 1/10W, 6.81K, 1%, S0805
R59	1	S25000-3922SMT	RESISTOR, SMD, METAL, FILM, 1/10W, 39.2K, 1%, S0805
R60, R70, R73, R74, R78, R83, R113, R150	8	S25000-1003SMT	RESISTOR, SMD, METAL, FILM, 1/10W, 100K, 1%, S0805
R71, R76, R94, R97, R118	5	S25000-7501SMT	RESISTOR, SMD, METAL, FILM, 1/10W, 7.50K, 1%, S0805
R72, R80, R95, R96, R117	5	S25000-2671SMT	RESISTOR, SMD, METAL, FILM, 1/10W, 2.67K, 1%, S0805
R85, R119, R129	3	S25000-1822SMT	RESISTOR, SMD, METAL, FILM, 1/10W, 1.82K, 1%, S0805
R88, R99	2	S25001-1210SMT	RESISTOR, SMD, METAL, FILM, 1/10W, 1.206, 1%, TR
R100	1	S25000-3570SMT	RESISTOR, SMD, METAL, FILM, 1/10W, 357OHMS, 1%, S0805
R114, R115	2	S25000-2000SMT	RESISTOR, SMD, METAL, FILM, 1/10W, 200OHMS, 1%, S0805
R148	1	S25000-6810SMT	RESISTOR, SMD, METAL, FILM, 1/10W, 681OHMS, 1%, S0805
R149, R159	2	T10812-41	TRIMMER, ST, 1/2W, 10K, 10%, LINEAR
R156	1	S25000-1652SMT	RESISTOR, SMD, METAL, FILM, 1/10W, 16.5K, 1%, S0805
S1	1	S19869-8	SWITCH, DIP, SPST, 8-CIRCUITS, 2775SET, SWITCH, POSITIONS????
N.A. X1	1	S15128-11SMT	IC, SMD, COMPARATOR, QUAD, 2901D
N.A. X2, X5, X6, X8, X11, X13	6	S15128-45SMT	OP AMP, SMD, QUAD, GEN PURPOSE, E, 224D
N.A. X3	1	S25078-12SMT	IC, SMD, CMOS, CPLD, CY37192, 160-TOFF(S)
N.A. X7	1	S25067-15SMT	IC, BIPOLAR, TIMER, SOIC-14
N.A. X9, X12	2	S15018-65SMT	IC, SMD, CMOS, SWITCH, ANALOG, QUAD, 4066BD(SS)
N.A. X10	1	S25057-25SMT	POT, SMD, DIGITAL, 10K, 1-CHNL, SOIC-8

UNLESS OTHERWISE SPECIFIED:  
CAPACITANCE = MFD/MLTS  
INDUCTANCE = HENRIES  
RESISTANCE = OHMS

ALL COMPONENTS AND MATERIALS USED IN THIS ASSEMBLY ARE TO BE ROHS COMPLIANT PER E4253.

<b>PROPRIETARY &amp; CONFIDENTIAL</b> THIS DOCUMENT IS THE PROPERTY OF LINCOLN ELECTRIC. IT CONTAINS PROPRIETARY INFORMATION AND IS NOT TO BE REPRODUCED, COPIED, OR DISCLOSED IN ANY MANNER WITHOUT THE EXPRESS WRITTEN PERMISSION OF LINCOLN ELECTRIC.		DESIGNED BY: FEI DRAWN BY: FEI CHECKED BY: FEI APPROVED BY: FEI	EQUIPMENT TYPE: <b>INDUSTRIAL TIG</b> SUBJECT: <b>ADVANCED CONTROL PC BOARD ASSEMBLY</b> MATERIAL DESCRIPTION: LF APPROVAL DATE: 3/16/2007 PROJECT NUMBER: CRM34409	PAGE 1 OF 1 DOCUMENT NUMBER: <b>G4040-2</b> REVISION: <b>B</b>
--	--	--	---	--

**NOTE:** Lincoln Electric assumes no responsibility for liabilities resulting from board level troubleshooting. PC Board repairs will invalidate your factory warranty. **Individual Printed Circuit Board Components are not available from Lincoln Electric.** This information is provided for reference only. Lincoln Electric discourages board level troubleshooting and repair since it may compromise the quality of the design and may result in danger to the Machine Operator or Technician. Improper PC board repairs could result in damage to the machine.







SCHEMATIC - TIG OPTION P.C. BOARD - ABOVE CODE 11000 (G4760 PAGE 2)

Return to Section TOC  
Return to Master TOC

Return to Section TOC  
Return to Master TOC

Return to Section TOC  
Return to Master TOC

Return to Section TOC  
Return to Master TOC

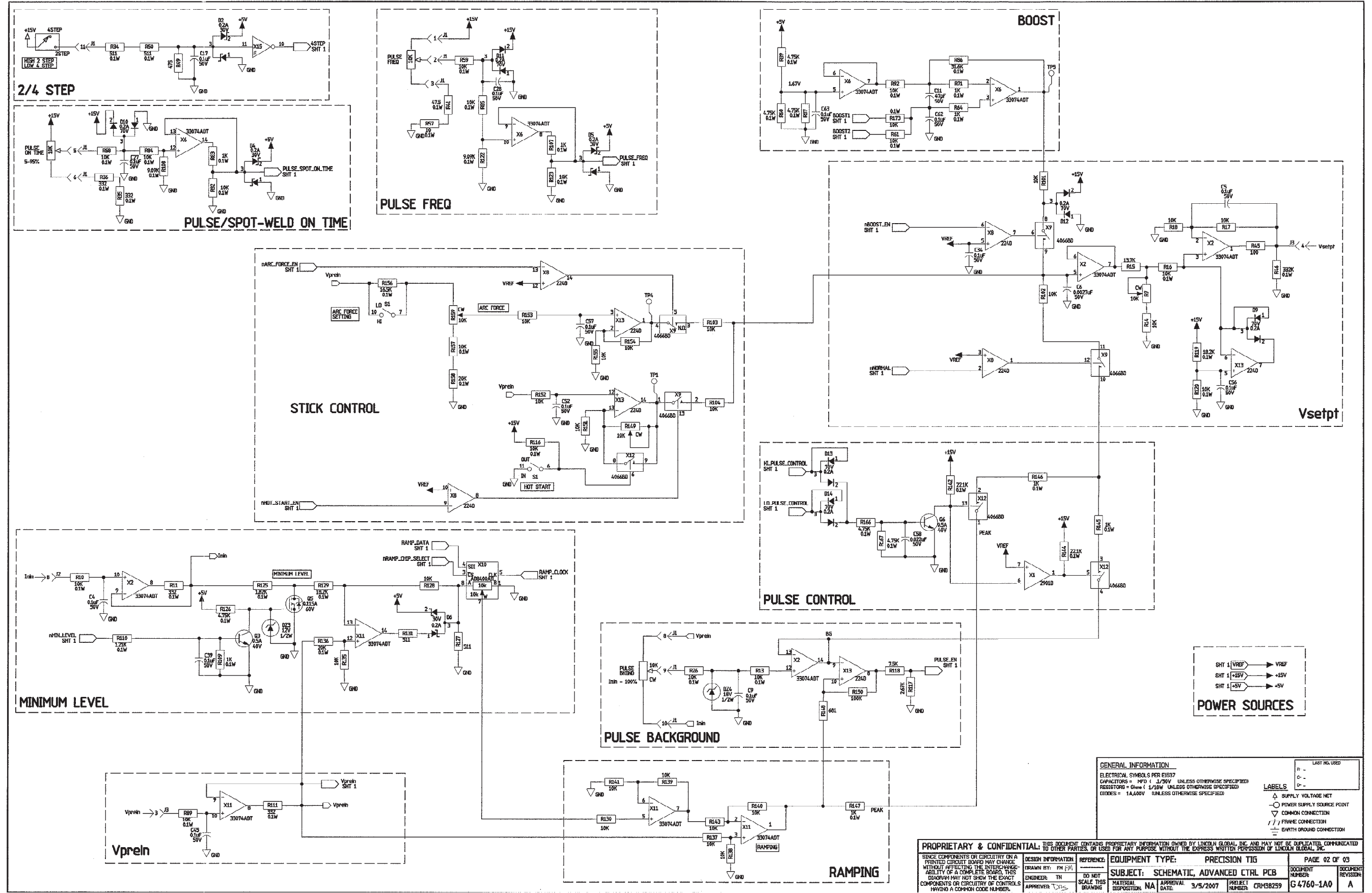

NOTE: This diagram is for reference only. It may not be accurate for all machines covered by this manual.



SCHEMATIC - TIG OPTION P.C. BOARD - ABOVE CODE 11000 (G4760 PAGE 3)

Return to Section TOC  
Return to Master TOC

Return to Section TOC  
Return to Master TOC

Return to Section TOC  
Return to Master TOC

Return to Section TOC  
Return to Master TOC

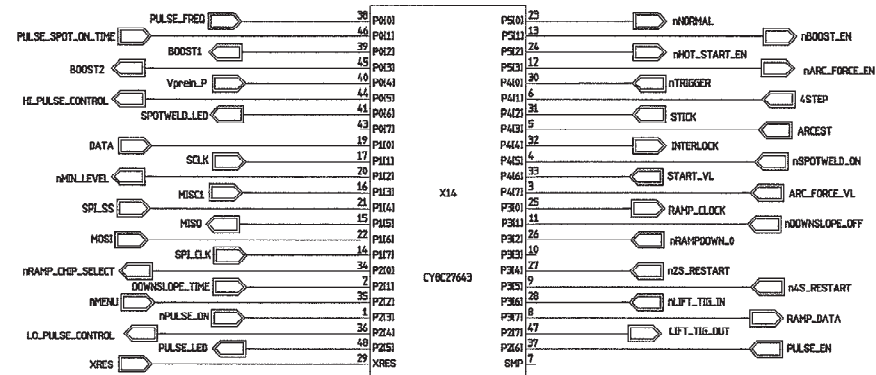

GENERAL INFORMATION		LAST NO. USED
ELECTRICAL SYMBOLS PER EJS37		R -
CAPACITORS = PFD (0.22/50V UNLESS OTHERWISE SPECIFIED)		C -
RESISTORS = 0.5W (1/4W UNLESS OTHERWISE SPECIFIED)		D -
DIODES = 1A/600V (1N4001 UNLESS OTHERWISE SPECIFIED)		
△ SUPPLY VOLTAGE NET ○ POWER SUPPLY SOURCE POINT ▽ COMMON CONNECTION ▮ FRAME CONNECTION ⊕ EARTH GROUND CONNECTION		LABELS

PROPRIETARY & CONFIDENTIAL: THIS DOCUMENT CONTAINS PROPRIETARY INFORMATION OWNED BY LINCOLN GLOBAL, INC. AND MAY NOT BE DUPLICATED, COMMUNICATED OR USED FOR ANY PURPOSE WITHOUT THE EXPRESS WRITTEN PERMISSION OF LINCOLN GLOBAL, INC.			
DESIGN INFORMATION	REFERENCE:	EQUIPMENT TYPE:	PAGE 03 OF 03
DRAWN BY: FM/FBI	DO NOT SCALE THIS DRAWING	PRECISION TIG	
ENGINEER: TN		SUBJECT: SCHEMATIC, ADVANCED CTRL PCB	DOCUMENT NUMBER:
APPROVED: [Signature]		MATERIAL DISPOSITION: NA	PROJECT NUMBER: CRM38259
		APPROVAL DATE: 3/5/2007	DOCUMENT REVISION: G4760-1A0 A

NOTE: This diagram is for reference only. It may not be accurate for all machines covered by this manual.



PC BOARD ASSEMBLY - TIG OPTION P.C. BOARD - ABOVE CODE 11000 (G4761-1)

Return to Section TOC  
Return to Master TOC

Return to Section TOC  
Return to Master TOC

Return to Section TOC  
Return to Master TOC

Return to Section TOC  
Return to Master TOC

1-19179 ENGINEERING CONTROLLED CHANGE DETAIL: RELEASED A01 FROM "X" MANUFACTURER: No

ITEM	QTY	PART NUMBER	DESCRIPTION
1	1	G4761-A	PC BOARD BLANK
2	1	S26859-1	PSOC SOFTWARE (X14)
3	AS REQ	E2861	SEALANT

REFER TO ELECTRONIC COMPONENT DATABASE FOR SPECIFICATIONS ON ITEMS LISTED BELOW

REFERENCES	QTY	PART NUMBER	DESCRIPTION
C1, C2, C4, C5, C7, C10, C12, C14, C15, C17, C18, C19, C20, C26, C29, C30, C31, C32, C33, C34, C38, C39, C43, C45, C49, C50, C51, C52, C53, C54, C55, C56, C57, C62, C63, C65	36	S25020-35MT	CAPACITOR,SMD,CERAMIC,0.1MF,50V,10%,XTR,S0805
C3, C8, C58, C64, C66	5	S25020-25MT	CAPACITOR,SMD,CERAMIC,0.022MF,50V,10%,XTR,S0805
C6	1	S25020-55MT	CAPACITOR,SMD,CERAMIC,2700PF,50V,5%,XTR,S0805
C9, C27, C28, C46	4	S25020-275MT	CAPACITOR,SMD,CER,0.1MF,50V,20%+80%,Z5U,S0805
C11	1	S25020-95MT	CAPACITOR,SMD,CERAMIC,47PF,50V,5%,COG,S0805
C35, C36, C37, C48	4	S25020-245MT	CAPACITOR,SMD,CERAMIC,1.0MF,25V,10%,XTR,S1206
C60	1	S25020-145MT	CAPACITOR,SMD,CERAMIC,330PF,100V,5%,COG,S0805
D1	1	S25040-25MT	DIODE,SMD,1A,400V,DO-214BA/AC
D2, D3, D4, D5, D6, D7, D8	7	S25049-45MT	DIODE,SMD,SCHOTTKY,DUAL,0.200A,30V,SOT-23
D9, D10, D11, D12, D13, D14	6	S25040-55MT	DIODE,SMD,DUAL,0.200A,70V,UFR
DZ1, DZ5	2	S25046-15MT	ZENER DIODE,SMD,0.5W,5.1V,5%,SOD123
DZ3	1	S25046-45MT	ZENER DIODE,SMD,0.5W,12V,5%,SOD-123
DZ4	1	S25046-35MT	ZENER DIODE,SMD,0.5W,18V,5%,SOD123
J1	1	S24020-12	CONNECTOR,MOLEX,MNL,PCB,12-PIN,TIN
J2, J3	2	S21135-10	CONNECTOR,MOLEX,MNL,CLIND,F,10-PIN
J20	1	S24020-2	CONNECTOR,MOLEX,MNL,PCB,2-PIN,TIN
J21	1	S24020-4	CONNECTOR,MOLEX,MNL,PCB,4-PIN,TIN
LED1, LED2	2	S25080-25MT	LED,SMD,GREEN,CLEAR,S1206
OC1	1	S15000-345MT	IC,SMD,OPTOCOUPLER,HMA124
Q2, Q3, Q6, Q7, Q8	5	S25050-15MT	TRANSISTOR,SMD,NPN,0.5A,40V,SOT-23,MMBT4401LT1
Q5	1	S25051-45MT	TRANSISTOR,SMD,NMF,SOT-23,0.115A,60V,7002LT1(S)
R1, R2, R3, R4, R5, R8, R25	7	S25000-22115MT	RESISTOR,SMD,METAL FILM,1/10W,2.21K,1%,S0805
R6, R10, R13, R14, R16, R17, R18, R21, R26, R28, R29, R32, R33, R48, R52, R58, R59, R61, R65, R72, R82, R84, R85, R89, R92, R101, R102, R103, R104, R116, R120, R123, R128, R130, R135, R137, R138, R139, R140, R141, R143, R151, R152, R153, R154, R155, R157	48	S25000-10025MT	RESISTOR,SMD,METAL FILM,1/10W,10.0K,1%,S0805
R7	1	S25058-15MT	TRIMMER,SMD,ST,14W,10K,10%LINEAR
R9, R148, R175	3	S25000-68105MT	RESISTOR,SMD,METAL FILM,1/10W,6810HMS,1%,S0805
R11, R35, R36, R106, R111, R124	6	S25000-33205MT	RESISTOR,SMD,METAL FILM,1/10W,3320HMS,1%,S0805
R12, R45, R169, R170, R171	5	S25000-10005MT	RESISTOR,SMD,METAL FILM,1/10W,1000HMS,1%,S0805
R15	1	S25000-13725MT	RESISTOR,SMD,METAL FILM,1/10W,13.7K,1%,S0805
R20	1	S25000-15015MT	RESISTOR,SMD,METAL FILM,1/10W,1.50K,1%,S0805
R22, R142, R144	3	S25000-22125MT	RESISTOR,SMD,METAL FILM,1/10W,22.1K,1%,S0805
R23, R136, R158	3	S25000-20025MT	RESISTOR,SMD,METAL FILM,1/10W,20.0K,1%,S0805
R24, R44, R110, R178	4	S25000-12115MT	RESISTOR,SMD,METAL FILM,1/10W,1.21K,1%,S0805
R27	2	S25000-32235MT	RESISTOR,SMD,METAL FILM,1/10W,322K,1%,S0805
R30, R31, R70	3	S25000-47525MT	RESISTOR,SMD,METAL FILM,1/10W,47.5K,1%,S0805
R34, R37, R38, R50, R67, R75, R76, R127, R131, R132, R133, R181	12	S25000-51105MT	RESISTOR,SMD,METAL FILM,1/10W,5110HMS,1%,S0805
R39, R60, R66, R87, R105, R126, R166, R167, R177	9	S25000-47515MT	RESISTOR,SMD,METAL FILM,1/10W,4.75K,1%,S0805
R41, R172, R176, R182, R183	5	S25000-47R55MT	RESISTOR,SMD,METAL FILM,1/10W,47.50HMS,1%,S0805
R42, R43, R47, R64, R68, R71, R83, R88, R90, R91, R107, R109, R112, R121, R145, R146, R147, R174, R179	19	S25000-10015MT	RESISTOR,SMD,METAL FILM,1/10W,1.00K,1%,S0805
R49, R51, R77, R134, R180	5	S25000-47505MT	RESISTOR,SMD,METAL FILM,1/10W,4750HMS,1%,S0805
R54, R69	2	S25000-33215MT	RESISTOR,SMD,METAL FILM,1/10W,3.32K,1%,S0805
R55, R125	2	S25000-18215MT	RESISTOR,SMD,METAL FILM,1/10W,1.82K,1%,S0805
R57, R97	2	S25000-10R05MT	RESISTOR,SMD,METAL FILM,1/10W,10.00HMS,1%,S0805
R73, R74, R150	3	S25000-10035MT	RESISTOR,SMD,METAL FILM,1/10W,100K,1%,S0805
R86	1	S25000-31625MT	RESISTOR,SMD,METAL FILM,1/10W,31.6K,1%,S0805
R94, R118	2	S25000-75015MT	RESISTOR,SMD,METAL FILM,1/10W,750K,1%,S0805
R95, R117	2	S25000-26715MT	RESISTOR,SMD,METAL FILM,1/10W,2.67K,1%,S0805
R96	1	S25084-25MT	THERMISTOR,SMD,PTC,0.35/1.40HMS,2.0A
R98, R99	2	S25001-12105MT	RESISTOR,SMD,1210HMS,1/4W,1206,1%,TR
R108, R122	2	S25000-90915MT	RESISTOR,SMD,METAL FILM,1/10W,9.09K,1%,S0805
R114, R115	2	S25000-20005MT	RESISTOR,SMD,METAL FILM,1/10W,2000HMS,1%,S0805
R119, R129	2	S25000-18225MT	RESISTOR,SMD,METAL FILM,1/10W,18.2K,1%,S0805
R149, R159	2	T10812-4T	TRIMMER,R,ST,12W,10K,10%LINEAR
R154	1	S25000-16525MT	RESISTOR,SMD,METAL FILM,1/10W,16.5K,1%,S0805
R154	1	S19869-8	SWITCH,DIP,SPST,B,CIRCUITS?????SET,SWITCH_POSITIONS????
U1	1	S15128-115MT	IC,SMD,COMPARATOR,QUAD,2901D
U2, X6, X11	3	S15128-285MT	IC,OP-AMP,SMT,QUAD,HIGH-PERF,33074ADT
U3	1	S25067-15MT	IC,BIPOLAR,TIMER,SOIC-14
U8, X13	2	S15128-45MT	OP-AMP,SMD,QUAD,GEN-PURPOSE,224D
U9, X12	2	S15018-65MT	IC,SMD,CMOS,SWITCH ANALOG,QUAD,4066BD(SS)
U10	1	S25057-25MT	IC,SMD,DIGITAL,10K,1-CHNL,SOIC-8
U11	1	S25073-125MT	IC,SMD,CMOS,PSOC,8-BIT,CY8C27643,TF49(SS)
U15, X16	2	S25065-35MT	IC,SMD,CMOS,INVERTER,SCHMITT,HEX,VHC14(SS)

UNLESS OTHERWISE SPECIFIED:  
CAPACITANCE = MFD/VOLTS  
INDUCTANCE = HENRIES  
RESISTANCE = OHMS

ALL COMPONENTS AND MATERIALS USED IN THIS ASSEMBLY ARE TO BE RoHS COMPLIANT PER E4253

**REVISION CONTROL**

G4761-1A0

PART NO. IDENTIFICATION CODE

TEST PER E4298-AC  
COAT WITH E1844 AND E3668  
SCHEMATIC REFERENCE: G4760-1A0

**MAKE DETAIL**

MANUFACTURE PER E1911  
BUY BLANK COMPLETE  
(6 BOARDS PER PANEL)

4 LAYER BOARD BLANK PANEL  
SEE ELECTRONIC FILE FOR ADDITIONAL INFORMATION.

NOTES:  
N.A. CAUTION: THIS DEVICE IS SUBJECT TO DAMAGE BY STATIC ELECTRICITY. SEE E2454 BEFORE HANDLING.  
N.B. PROGRAM X14 WITH ITEM 2 AND LABEL X14 WITH PART NUMBER OF ITEM 2.  
N.C. APPLY ITEM 3 TO COMPONENT SIDE OF BOARD AS SHOWN.  
N.D. DO NOT COAT WITH ENCAPSULATION MATERIAL.  
N.E. KEEP MOUNTING HOLES FREE OF ENCAPSULATION MATERIAL (5 PLACES)  
N.F. KEEP TOP SURFACE OF TRIMMERS FREE OF ENCAPSULATION MATERIAL (2 PLACES)  
N.G. KEEP TOP SURFACE OF DIP SWITCH FREE OF ENCAPSULATION MATERIAL.  
N.H. APPLY ITEM 3 AROUND BASE OF J2 & J3 ON BACK SIDE OF BOARD. LIMIT HEIGHT TO .125 +/- 0.025 INCHES.  
N.J. APPLY ITEM 3 TO CONNECTOR'S PLASTIC MOUNTING PINS.



NOTE: Lincoln Electric assumes no responsibility for liabilities resulting from board level troubleshooting. PC Board repairs will invalidate your factory warranty. Individual Printed Circuit Board Components are not available from Lincoln Electric. This information is provided for reference only. Lincoln Electric discourages board level troubleshooting and repair since it may compromise the quality of the design and may result in danger to the Machine Operator or Technician. Improper PC board repairs could result in damage to the machine.

PROPRIETARY & CONFIDENTIAL		THIS DOCUMENT IS THE PROPERTY OF LINCOLN ELECTRIC. IT IS TO BE USED ONLY FOR THE PURPOSES SPECIFIED HEREIN. IT IS NOT TO BE REPRODUCED, COPIED, OR TRANSMITTED IN ANY FORM OR BY ANY MEANS, ELECTRONIC OR MECHANICAL, INCLUDING PHOTOCOPYING, RECORDING, OR BY ANY INFORMATION STORAGE AND RETRIEVAL SYSTEM, WITHOUT THE EXPRESS WRITTEN PERMISSION OF LINCOLN ELECTRIC.	
DESIGN BY: J. Smith	REFERENCE: G4040	EQUIPMENT TYPE: INDUSTRIAL TIG	PAGE 1 OF 1
ENGINTEER: T. Nguyen	SCALE: 1:1	SUBJECT: ADVANCED CONTROL PC BOARD ASSEMBLY	DOCUMENT NUMBER: G4761-1
APPROVAL DATE: 3/5/2007	PROJECT NUMBER: CRM38259	REVISION: A	

