

# SA 400I WIRING DIAGRAM M25546 REV: B

CONTROL PANEL COMPONENTS SHOWN AS VIEWED FROM REAR.

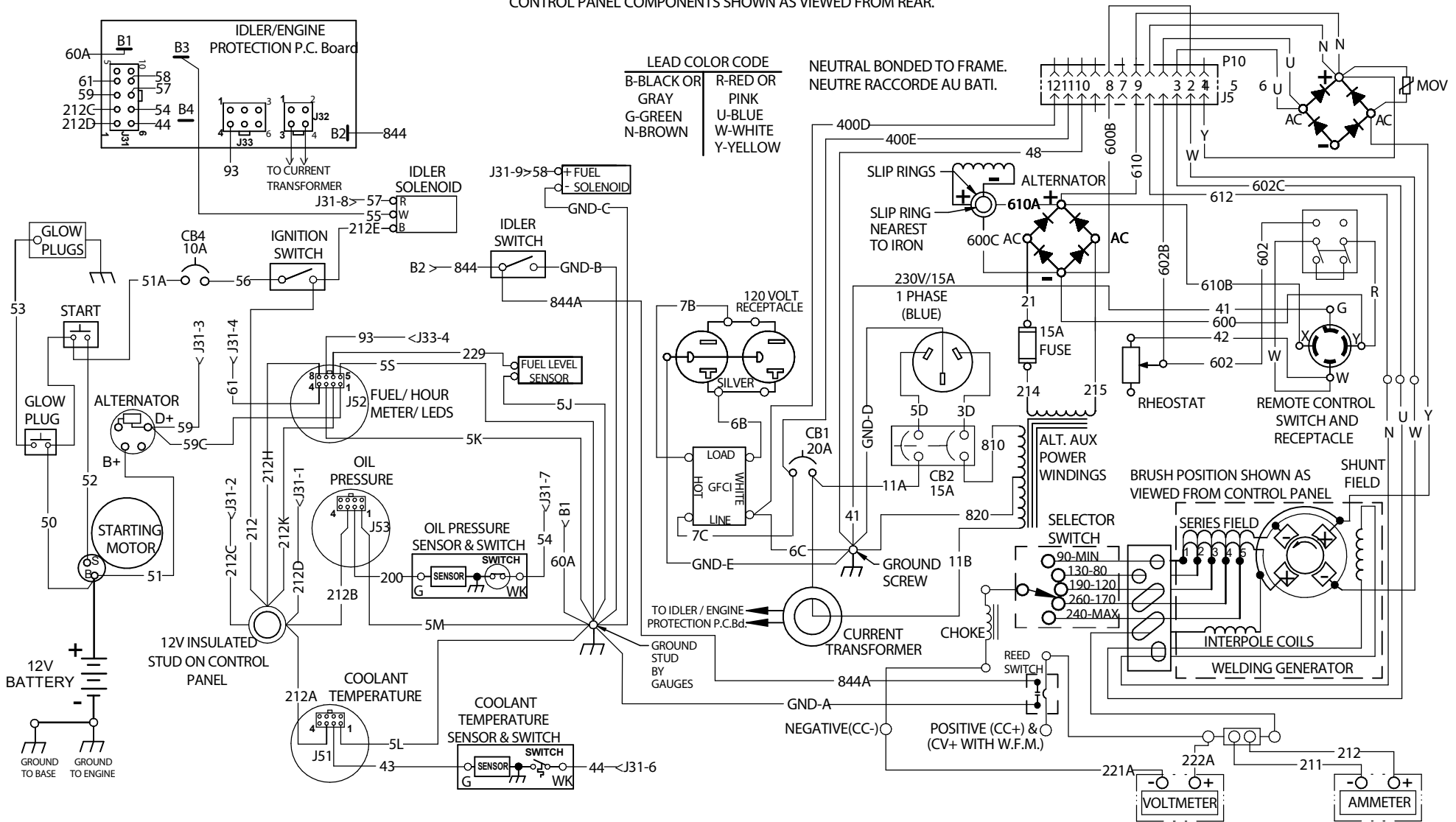

## WIRE FEED MODULE (OPTIONAL)

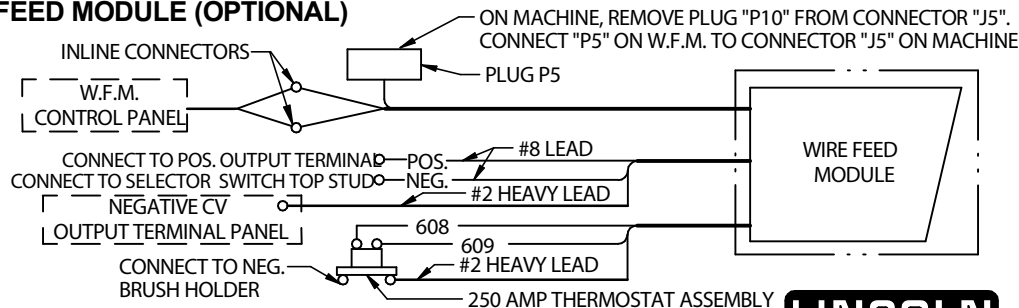

## REMOTE CONTROL (OPTIONAL)

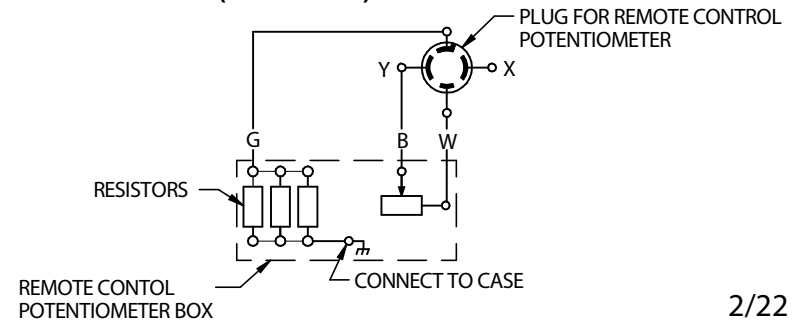

MACHINE MUST NOT BE RUNNING WHEN MAKING THESE CONNECTIONS.

**LINCOLN**  
**ELECTRIC**