

DH-10 CONTROL DUAL FEEDERS WIRING DIAGRAM L10218 REV: J

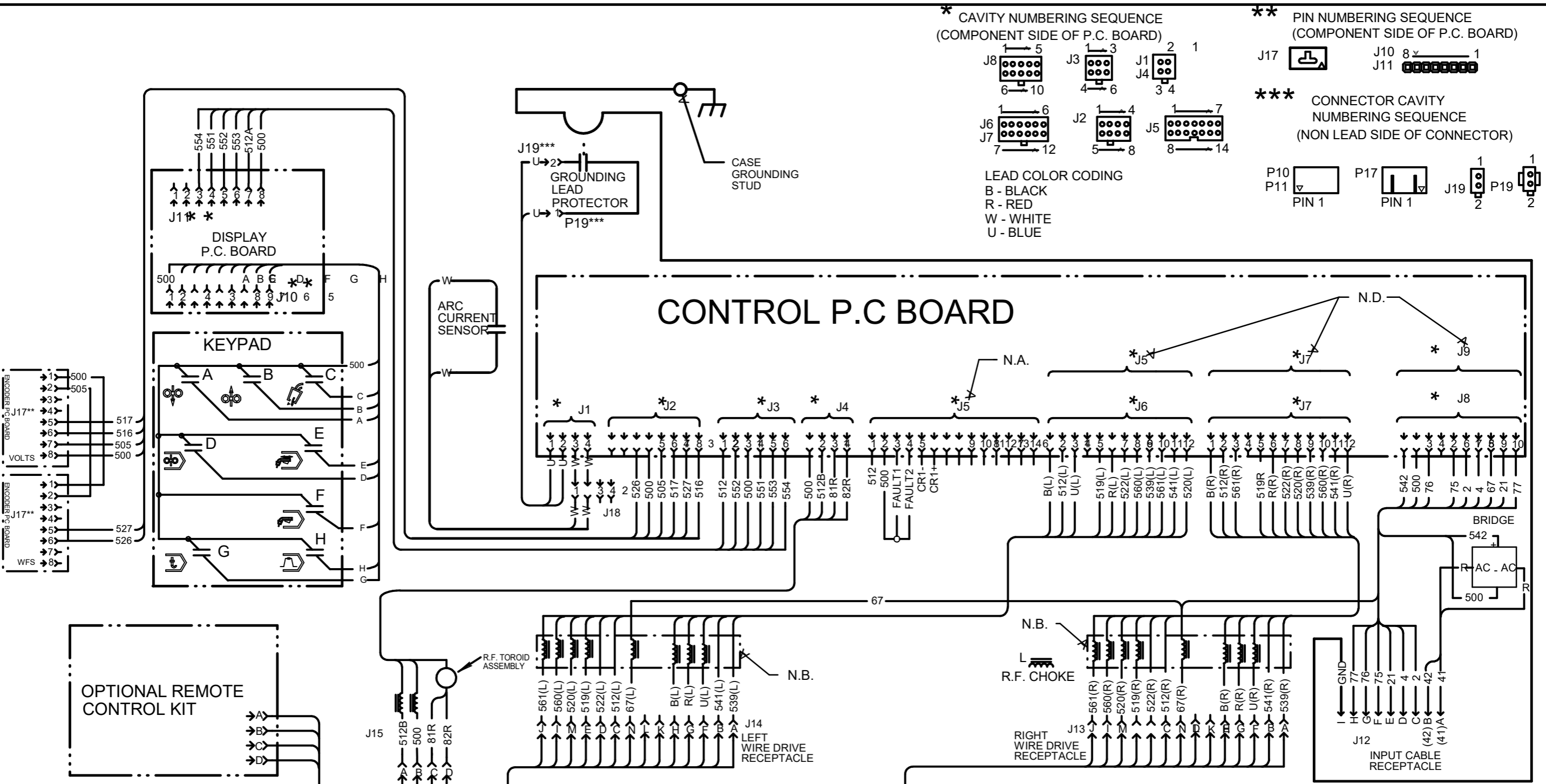

*** CAVITY NUMBERING SEQUENCE**
(COMPONENT SIDE OF P.C. BOARD)

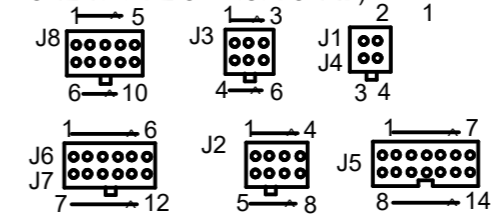

LEAD COLOR CODING
B - BLACK
R - RED
W - WHITE
U - BLUE

**** PIN NUMBERING SEQUENCE**
(COMPONENT SIDE OF P.C. BOARD)

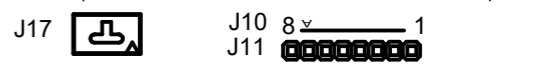

***** CONNECTOR CAVITY NUMBERING SEQUENCE**
(NON LEAD SIDE OF CONNECTOR)

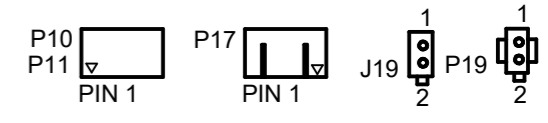

NOTES:
N.A. FOR G3041-2 AND HIGHER CONTROL P.C. BOARDS: THE JUMPER (SHOWN) OR THE OPTIONAL REMOTE SWITCH INTERFACE MODULE (NOT SHOWN) MUST BE INSTALLED IN J5 ON THE CONTROL P.C. BOARD FOR THE DH-10 TO OPERATE. (G3041-1 CONTROL P.C. BOARDS DO NOT HAVE THIS CONNECTOR.)
N.B. THESE CHOKES MAY NOT BE PRESENT ON NEWER MODELS.
N.C. WHITE LEADS 560 AND 561 MAY NOT BE LABELED ON EARLIER MODELS.
N.D. UPPER BRACKETS INDICATE ALTERNATE CONNECTOR NUMBERS USED ON G3041-1 CONTROL P.C. BOARDS (CONNECTIONS J6 & J8 OF G3041-1 ARE NOT SHOWN.)

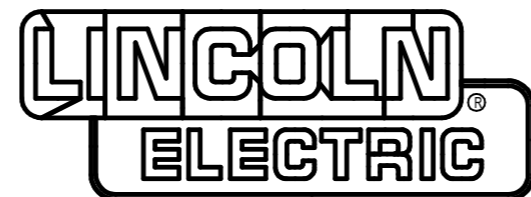
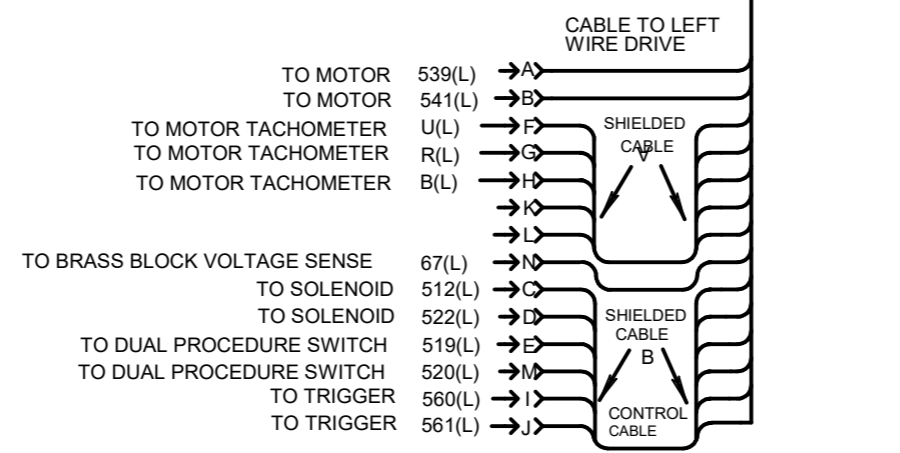

CLEVELAND, OHIO U.S.A.