

**CODE 50019, 50020, 50021, 50022**

ASSEMBLY PAGE NAME			Machine Assembly	Machine assembly (rear side)	
CODE NO.:	K NO.:	FIGURE NO.:	A	B	
50019	K14013-1	POWERTEC 280C PRO	1	1	
50020	K14014-1	POWERTEC 350C PRO	2	1	
50021	K14015-1A	POWERTEC 420C PRO	3	2	
50022	K14015-1W	POWERTEC 420C PRO W	4	3	

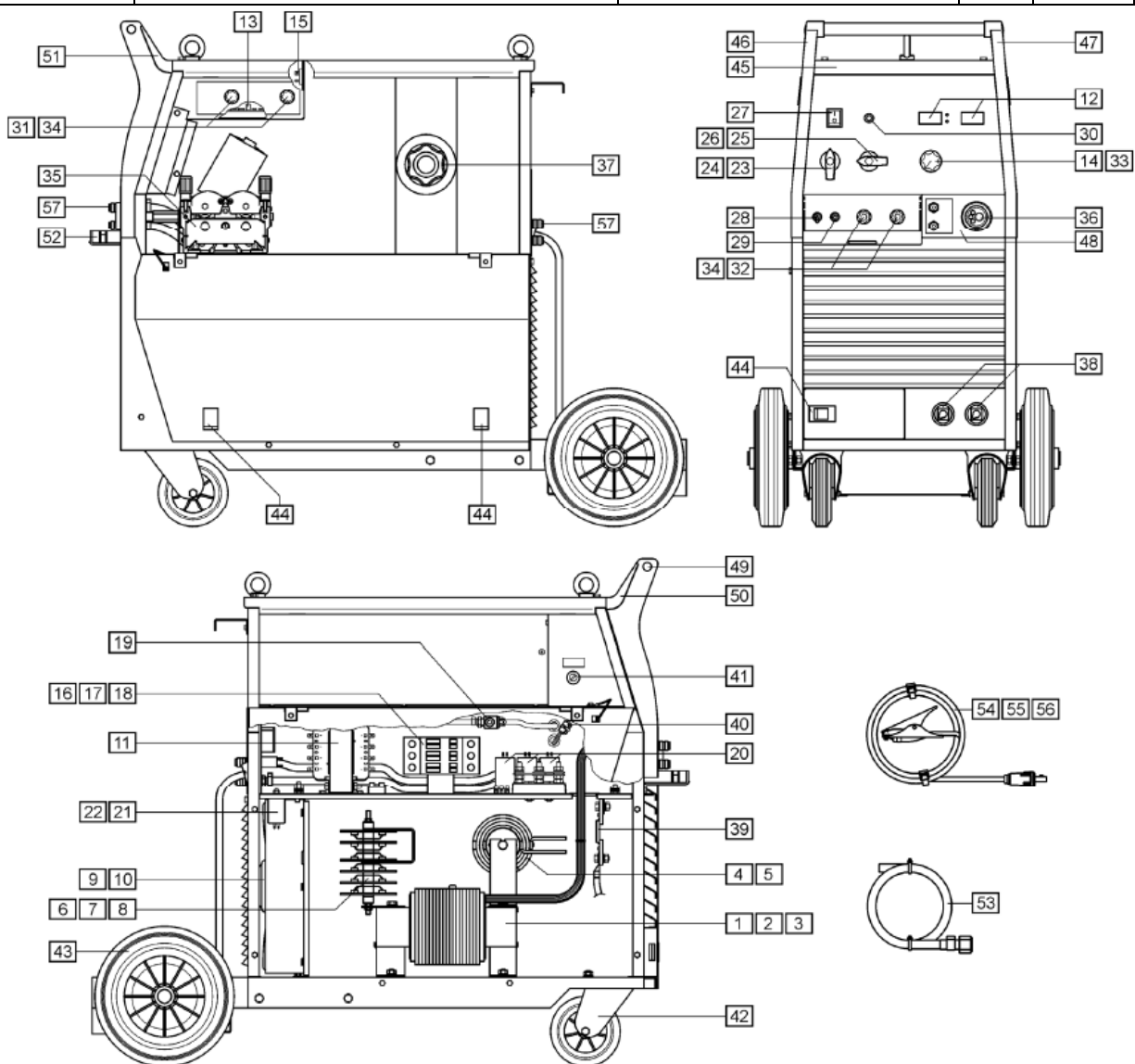
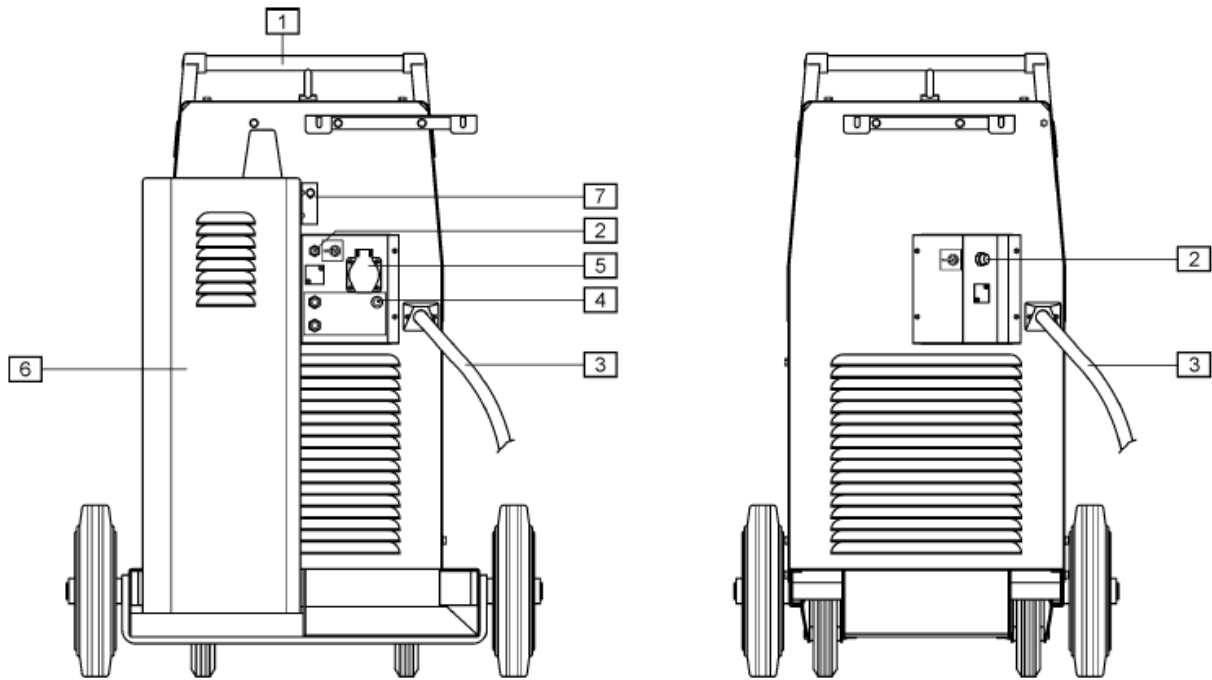

**FIGURE A: Machine assembly**

Item	Description	part number	QTY	1	2	3	4
1	MAIN TRANSFORMER T1	B-4247-486-2R	1	X	-	-	-
2	MAIN TRANSFORMER T1	B-4247-484-2R	1	-	X	-	-
3	MAIN TRANSFORMER T1	B-4247-485-2R	1	-	-	X	X
4	CHOKE L1	C-4244-383-2R	1	X	-	-	-

5	CHOKE L1	C-4244-383-4R	1	-	X	X	X
6	RECTIFIER SET V1	1156-112-069R	1	X	-	-	-
7	RECTIFIER SET V1	1156-112-070R	1	-	X	-	-
8	RECTIFIER SET V1	1156-112-071R	1	-	-	X	X
9	FAN M1	1111-311-081R	1	X	X	-	-
10	FAN M1	0874-111-002R	1	-	-	X	X
11	AUXILIARY TRANSFORMER T2	C-4244-384-1R	1	X	X	X	X
12	CONTROL P.C BOARD G4560	C-3731-399-2R	1	X	X	X	X
13	CONTROL P.C BOARD US-67	0918-432-068R	1	X	X	X	X
14	CONTROL P.C BOARD PD-5	0918-432-073R	1	X	X	X	X
15	RECTIFIER SET V2	1156-112-044R	1	X	X	X	X
16	CONTACTOR K1	1115-212-177R	1	X	-	-	-
17	CONTACTOR K1	1115-212-178R	1	-	X	-	-
18	CONTACTOR K1	1115-212-179R	1	-	-	X	X
19	GAS VALVE K2	0972-423-012R	1	X	X	X	X
20	CAPACITORS C1,C2,C3	1158-121-010R	3	X	X	X	X
21	CAPACITOR C4	1158-121-045R	1	X	X	-	-
22	CAPACITOR C4	1158-121-001R	1	-	-	X	X
23	VOLTAGE SWITCH S2	1115-260-166R	1	X	-	-	-
24	VOLTAGE SWITCH S2	1115-260-073R	1	-	X	X	X
25	VOLTAGE SWITCH S1	1115-260-167R	1	X	-	-	-
26	VOLTAGE SWITCH S1	1115-260-074R	1	-	X	-	-
27	MAIN SWITCH S3	1115-270-019R	1	X	X	X	X
28	SWITCH S7	1158-650-021R	1	X	X	X	X
29	SWITCH S6	1158-650-022R	1	X	X	X	X
30	LAMP H1	0917-421-024R	1	X	X	X	X
31	SWITCH S4,S5	1115-299-052R	2	X	X	X	X
32	POTENTIOMETERS R11,R12	1158-113-304R	2	X	X	X	X
33	KNOB	9ET10491R	1	X	X	X	X
34	KNOB	9ET13639-3R	4	X	X	X	X
35	FEEDING UNIT (complete)	C-6713-007-1R	1	X	X	X	X
36	EURO SOCKET (outlet guide)	C-2985-006-1R	1	X	X	X	X
37	SLEEVE	0744-000-192R	1	X	X	X	X
38	SOCKET X2,X3	C-2986-001-2R	2	X	X	X	X
39	SHUNT B1	0941-712-026R	1	X	X	X	X
40	FERRITE TUBE	1158-290-036R	1	X	X	X	X
41	FUSE F1	1158-660-006R	1	X	X	X	X
42	TURNING WHEEL	1029-660-127R	2	X	X	X	X
43	WHEEL	1029-660-250R	2	X	X	X	X
44	HINGE	0654-610-004R	5	X	X	X	X
45	EDGE SHIELD	1362-212-010R	1	X	X	X	X
46	LEFT HOLDER	1362-212-002R	1	X	X	X	X
47	RIGHT HOLDER	1362-212-003R	1	X	X	X	X
48	EURO SOCKET (insulator)	1362-212-009R	1	X	X	X	X
49	CAP	1362-212-004R	2	X	X	X	X
50	LEFT SIDE HANDLE ASSEMBLY	1362-212-006R	1	X	X	X	X
51	RIGHT SIDE HANDLE ASSEMBLY	1362-212-007R	1	X	X	X	X
52	SMALL FLAP	1362-212-001R	1	X	X	X	X
53	GAS HOSE -2m	D-5578-174-1R	1	X	X	X	X

54	GROUND CABLE with WORK CLAMP - 3m	K14011-1	1	X	-	-	-
55	GROUND CABLE with WORK CLAMP - 3m	K14018-1	1	-	X	-	-
56	GROUND CABLE with WORK CLAMP - 3m	K14019-1	1	-	-	X	X
57	QUICK CONNECT COUPLING (ONLY WATER)	0744-000-151R	4	-	-	-	X
58	FRONT PANEL	C-3721-828-1/08R	1	-	X	X	X
59	FRONT PANEL	C-3721-828-2/08R	1	X	-	-	-
60	LEFT SIDE PANEL WITH LABELS	C-3721-836-1R	1	X	-	-	-
61	LEFT SIDE PANEL WITH LABELS	C-3721-836-2R	1	-	X	-	-
61	LEFT SIDE PANEL WITH LABELS	C-3721-836-3R	1	-	-	X	-
62	LEFT SIDE PANEL WITH LABELS	C-3721-836-4R	1	-	-	-	X
63	RIGHT SIDE PANEL WITH LABEL	D-3721-392-4R	1	X	-	-	-
64	RIGHT SIDE PANEL WITH LABEL	D-3721-392-5R	1	-	X	-	-
65	RIGHT SIDE PANEL WITH LABEL	D-3721-392-6R	1	-	-	X	X
66	LEFT SIDE PANEL	D-3721-401-1/33R	1	X	X	X	X
67	RIGHT SIDE PANEL	C-3721-814-2/33R	1	X	X	X	X
68	REAR PANEL	C-3721-827-1/08R	1	X	X	X	X
69	TOP PANEL	D-3773-044-2R	1	X	X	X	X
70	FRONT LABEL	2719-107-086R	1	X	-	-	-
71	FRONT LABEL	2719-107-087R		-	X	X	X



**FIGURE B: Machine assembly (rear side)**

Item	Description	part number	QTY	1	2	3
1	HANDLE	0562-230-005R	1	X	X	X
2	GAS INLET SOCKET	D-1891-135-1R	1	X	X	X
3	MAINS CORD whitout PLUG -5m (4x4mm <sup>2</sup> )	D-5578-171-2R	1	X	-	-
3	MAINS CORD whitout PLUG -5m (4x6mm <sup>2</sup> )	D-5578-171-3R	1	-	X	X
4	CIRCUIT BREAKER Q1 (ONLY WATER)	1115-299-027R	1	-	-	X
5	SOCKET X16 (ONLY WATER)	1131-222-004R	1	-	-	X
6	WATER COOLER (ONLY WATER)	K10329	1	-	-	X
7	COOLER BRACKET (ONLY WATER)	D-2632-641-1/33R	1	-	-	X