

Inert Gas Guard Regulators (IGG)

4 Operation Modes Available.



The Harris Products Group
 A Lincoln Electric Company
 2345 Murphy Blvd., Gainesville GA. 30504
 Phone: 1.800.733.4043 FAX: 770.535.0544
 www.harrisproductsgroup.com

1. Fully Adjustable (as shipped)

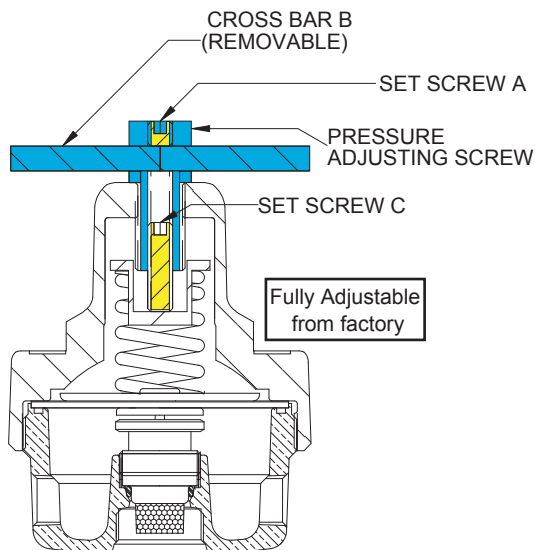

As shipped from factory, the unit is fully adjustable from zero to the maximum flow rate.

2. Fixed Maximum

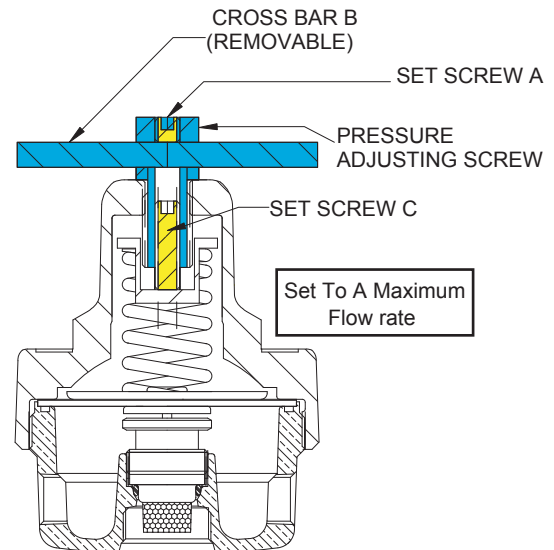

1. Tighten adjusting screw against bonnet.
2. Remove set screw A and cross bar B.
3. With gas flowing, adjust set screw C to the desired maximum flow. Flow rate is adjustable from zero to fixed maximum.
4. Replace cross bar B and set screw C.

3. Fixed

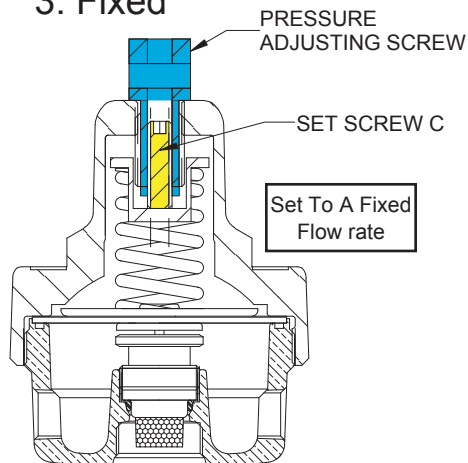

1. Tighten adjusting screw against bonnet.
2. Remove set screw A and cross bar B.
3. With gas flowing, adjust set screw C to the desired flow. Flow rate is not fully adjustable by the operator once preset. Flow rate, however, can be reduced or turned off completely for service or safety.

4. Fixed and Locked

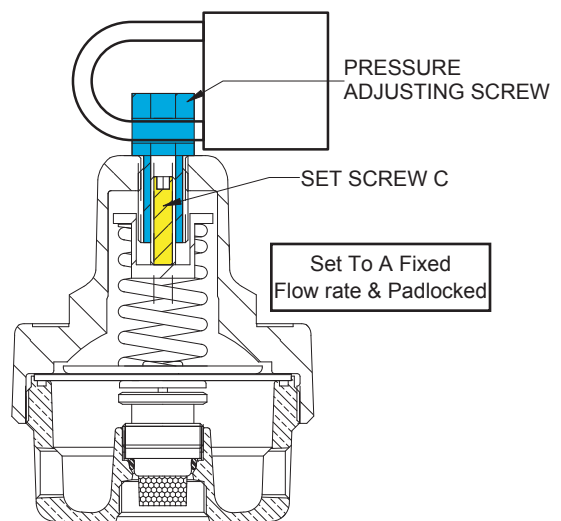

1. Apply thread locker Locktite® 271 or equal and tighten set screw against bonnet.
2. Remove set screw A and cross bar B.
3. With gas flowing, adjust set screw C with allen wrench to the desired flow rate.
4. Install padlock (not supplied with IGG). Flow rate can be adjusted or turned off completely by removing lock and using allen wrench