

**INVERTEC™ V155-S**For use with machines having Code Numbers: **11326; 11327****PRODUCT  
REGISTRATION**

Registering your product only takes a few minutes, ensures your qualification for available warranties and allows you to receive updates and information on your product.

Follow the QR code below to register.



[https://lered.info/product\\_registration-7](https://lered.info/product_registration-7)

**Safety Depends on You**

Lincoln arc welding and cutting equipment is designed and built with safety in mind. However, your overall safety can be increased by proper installation ... and thoughtful operation on your part. **DO NOT INSTALL, OPERATE OR REPAIR THIS EQUIPMENT WITHOUT READING THIS MANUAL AND THE SAFETY PRECAUTIONS CONTAINED THROUGHOUT.** And, most importantly, think before you act and be careful.

**OPERATOR'S MANUAL**

Copyright © 2007 Lincoln Global Inc.

• World's Leader in Welding and Cutting Products •

• Sales and Service through Subsidiaries and Distributors Worldwide •

Cleveland, Ohio 44117-1199 U.S.A. TEL: 216.481.8100 FAX: 216.486.1751 WEB SITE: <https://lered.info/locator>

## ⚠ WARNING



### CALIFORNIA PROPOSITION 65 WARNINGS



Diesel engine exhaust and some of its constituents are known to the State of California to cause cancer, birth defects, and other reproductive harm.

The Above For Diesel Engines

The engine exhaust from this product contains chemicals known to the State of California to cause cancer, birth defects, or other reproductive harm.

The Above For Gasoline Engines

**ARC WELDING CAN BE HAZARDOUS. PROTECT YOURSELF AND OTHERS FROM POSSIBLE SERIOUS INJURY OR DEATH. KEEP CHILDREN AWAY. PACEMAKER WEARERS SHOULD CONSULT WITH THEIR DOCTOR BEFORE OPERATING.**

Read and understand the following safety highlights. For additional safety information, it is strongly recommended that you purchase a copy of "Safety in Welding & Cutting - ANSI Standard Z49.1" from the American Welding Society, P.O. Box 351040, Miami, Florida 33135 or CSA Standard W117.2-1974. A Free copy of "Arc Welding Safety" booklet E205 is available from the Lincoln Electric Company, 22801 St. Clair Avenue, Cleveland, Ohio 44117-1199.

**BE SURE THAT ALL INSTALLATION, OPERATION, MAINTENANCE AND REPAIR PROCEDURES ARE PERFORMED ONLY BY QUALIFIED INDIVIDUALS.**



### FOR ENGINE powered equipment.

1.a. Turn the engine off before troubleshooting and maintenance work unless the maintenance work requires it to be running.



1.b. Operate engines in open, well-ventilated areas or vent the engine exhaust fumes outdoors.



1.c. Do not add the fuel near an open flame welding arc or when the engine is running. Stop the engine and allow it to cool before refueling to prevent spilled fuel from vaporizing on contact with hot engine parts and igniting. Do not spill fuel when filling tank. If fuel is spilled, wipe it up and do not start engine until fumes have been eliminated.

1.d. Keep all equipment safety guards, covers and devices in position and in good repair. Keep hands, hair, clothing and tools away from V-belts, gears, fans and all other moving parts when starting, operating or repairing equipment.

1.e. In some cases it may be necessary to remove safety guards to perform required maintenance. Remove guards only when necessary and replace them when the maintenance requiring their removal is complete. Always use the greatest care when working near moving parts.



1.f. Do not put your hands near the engine fan. Do not attempt to override the governor or idler by pushing on the throttle control rods while the engine is running.

1.g. To prevent accidentally starting gasoline engines while turning the engine or welding generator during maintenance work, disconnect the spark plug wires, distributor cap or magneto wire as appropriate.



1.h. To avoid scalding, do not remove the radiator pressure cap when the engine is hot.

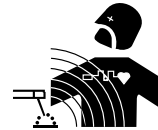

### ELECTRIC AND MAGNETIC FIELDS may be dangerous

2.a. Electric current flowing through any conductor causes localized Electric and Magnetic Fields (EMF). Welding current creates EMF fields around welding cables and welding machines

2.b. EMF fields may interfere with some pacemakers, and welders having a pacemaker should consult their physician before welding.

2.c. Exposure to EMF fields in welding may have other health effects which are now not known.

2.d. All welders should use the following procedures in order to minimize exposure to EMF fields from the welding circuit:

2.d.1. Route the electrode and work cables together - Secure them with tape when possible.

2.d.2. Never coil the electrode lead around your body.

2.d.3. Do not place your body between the electrode and work cables. If the electrode cable is on your right side, the work cable should also be on your right side.

2.d.4. Connect the work cable to the workpiece as close as possible to the area being welded.

2.d.5. Do not work next to welding power source.

Mar '95



## ELECTRIC SHOCK can kill.

- 3.a. The electrode and work (or ground) circuits are electrically "hot" when the welder is on. Do not touch these "hot" parts with your bare skin or wet clothing. Wear dry, hole-free gloves to insulate hands.
- 3.b. Insulate yourself from work and ground using dry insulation. Make certain the insulation is large enough to cover your full area of physical contact with work and ground.
- In addition to the normal safety precautions, if welding must be performed under electrically hazardous conditions (in damp locations or while wearing wet clothing; on metal structures such as floors, gratings or scaffolds; when in cramped positions such as sitting, kneeling or lying, if there is a high risk of unavoidable or accidental contact with the workpiece or ground) use the following equipment:**
- Semiautomatic DC Constant Voltage (Wire) Welder.
  - DC Manual (Stick) Welder.
  - AC Welder with Reduced Voltage Control.
- 3.c. In semiautomatic or automatic wire welding, the electrode, electrode reel, welding head, nozzle or semiautomatic welding gun are also electrically "hot".
- 3.d. Always be sure the work cable makes a good electrical connection with the metal being welded. The connection should be as close as possible to the area being welded.
- 3.e. Ground the work or metal to be welded to a good electrical (earth) ground.
- 3.f. Maintain the electrode holder, work clamp, welding cable and welding machine in good, safe operating condition. Replace damaged insulation.
- 3.g. Never dip the electrode in water for cooling.
- 3.h. Never simultaneously touch electrically "hot" parts of electrode holders connected to two welders because voltage between the two can be the total of the open circuit voltage of both welders.
- 3.i. When working above floor level, use a safety belt to protect yourself from a fall should you get a shock.
- 3.j. Also see Items 6.c. and 8.



## ARC RAYS can burn.

- 4.a. Use a shield with the proper filter and cover plates to protect your eyes from sparks and the rays of the arc when welding or observing open arc welding. Headshield and filter lens should conform to ANSI Z87.1 standards.
- 4.b. Use suitable clothing made from durable flame-resistant material to protect your skin and that of your helpers from the arc rays.
- 4.c. Protect other nearby personnel with suitable, non-flammable screening and/or warn them not to watch the arc nor expose themselves to the arc rays or to hot spatter or metal.



## FUMES AND GASES can be dangerous.

- 5.a. Welding may produce fumes and gases hazardous to health. Avoid breathing these fumes and gases. When welding, keep your head out of the fume. Use enough ventilation and/or exhaust at the arc to keep fumes and gases away from the breathing zone. **When welding with electrodes which require special ventilation such as stainless or hard facing (see instructions on container or MSDS) or on lead or cadmium plated steel and other metals or coatings which produce highly toxic fumes, keep exposure as low as possible and below Threshold Limit Values (TLV) using local exhaust or mechanical ventilation. In confined spaces or in some circumstances, outdoors, a respirator may be required. Additional precautions are also required when welding on galvanized steel.**
5. b. The operation of welding fume control equipment is affected by various factors including proper use and positioning of the equipment, maintenance of the equipment and the specific welding procedure and application involved. Worker exposure level should be checked upon installation and periodically thereafter to be certain it is within applicable OSHA PEL and ACGIH TLV limits.
- 5.c. Do not weld in locations near chlorinated hydrocarbon vapors coming from degreasing, cleaning or spraying operations. The heat and rays of the arc can react with solvent vapors to form phosgene, a highly toxic gas, and other irritating products.
- 5.d. Shielding gases used for arc welding can displace air and cause injury or death. Always use enough ventilation, especially in confined areas, to insure breathing air is safe.
- 5.e. Read and understand the manufacturer's instructions for this equipment and the consumables to be used, including the material safety data sheet (MSDS) and follow your employer's safety practices. MSDS forms are available from your welding distributor or from the manufacturer.
- 5.f. Also see item 1.b.

AUG 06

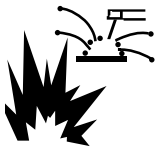

## WELDING and CUTTING SPARKS can cause fire or explosion.

6.a. Remove fire hazards from the welding area. If this is not possible, cover them to prevent the welding sparks from starting a fire.

Remember that welding sparks and hot materials from welding can easily go through small cracks and openings to adjacent areas. Avoid welding near hydraulic lines. Have a fire extinguisher readily available.

- 6.b. Where compressed gases are to be used at the job site, special precautions should be used to prevent hazardous situations. Refer to "Safety in Welding and Cutting" (ANSI Standard Z49.1) and the operating information for the equipment being used.
- 6.c. When not welding, make certain no part of the electrode circuit is touching the work or ground. Accidental contact can cause overheating and create a fire hazard.
- 6.d. Do not heat, cut or weld tanks, drums or containers until the proper steps have been taken to insure that such procedures will not cause flammable or toxic vapors from substances inside. They can cause an explosion even though they have been "cleaned". For information, purchase "Recommended Safe Practices for the Preparation for Welding and Cutting of Containers and Piping That Have Held Hazardous Substances", AWS F4.1 from the American Welding Society (see address above).
- 6.e. Vent hollow castings or containers before heating, cutting or welding. They may explode.
- 6.f. Sparks and spatter are thrown from the welding arc. Wear oil free protective garments such as leather gloves, heavy shirt, cuffless trousers, high shoes and a cap over your hair. Wear ear plugs when welding out of position or in confined places. Always wear safety glasses with side shields when in a welding area.
- 6.g. Connect the work cable to the work as close to the welding area as practical. Work cables connected to the building framework or other locations away from the welding area increase the possibility of the welding current passing through lifting chains, crane cables or other alternate circuits. This can create fire hazards or overheat lifting chains or cables until they fail.
- 6.h. Also see item 1.c.
- 6.i. Read and follow NFPA 51B "Standard for Fire Prevention During Welding, Cutting and Other Hot Work", available from NFPA, 1 Batterymarch Park, PO box 9101, Quincy, Ma 022690-9101.
- 6.j. Do not use a welding power source for pipe thawing.

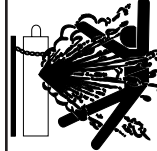

## CYLINDER may explode if damaged.

7.a. Use only compressed gas cylinders containing the correct shielding gas for the process used and properly operating regulators designed for the gas and pressure used. All hoses, fittings, etc. should be suitable for the application and maintained in good condition.

- 7.b. Always keep cylinders in an upright position securely chained to an undercarriage or fixed support.
- 7.c. Cylinders should be located:
- Away from areas where they may be struck or subjected to physical damage.
  - A safe distance from arc welding or cutting operations and any other source of heat, sparks, or flame.
- 7.d. Never allow the electrode, electrode holder or any other electrically "hot" parts to touch a cylinder.
- 7.e. Keep your head and face away from the cylinder valve outlet when opening the cylinder valve.
- 7.f. Valve protection caps should always be in place and hand tight except when the cylinder is in use or connected for use.
- 7.g. Read and follow the instructions on compressed gas cylinders, associated equipment, and CGA publication P-1, "Precautions for Safe Handling of Compressed Gases in Cylinders," available from the Compressed Gas Association 1235 Jefferson Davis Highway, Arlington, VA 22202.



## FOR ELECTRICALLY powered equipment.

- 8.a. Turn off input power using the disconnect switch at the fuse box before working on the equipment.
- 8.b. Install equipment in accordance with the U.S. National Electrical Code, all local codes and the manufacturer's recommendations.
- 8.c. Ground the equipment in accordance with the U.S. National Electrical Code and the manufacturer's recommendations.

Jan, 07

## PRÉCAUTIONS DE SÛRETÉ

Pour votre propre protection lire et observer toutes les instructions et les précautions de sûreté spécifiques qui paraissent dans ce manuel aussi bien que les précautions de sûreté générales suivantes:

### Sûreté Pour Soudage A L'Arc

1. Protégez-vous contre la secousse électrique:
  - a. Les circuits à l'électrode et à la pièce sont sous tension quand la machine à souder est en marche. Eviter toujours tout contact entre les parties sous tension et la peau nue ou les vêtements mouillés. Porter des gants secs et sans trous pour isoler les mains.
  - b. Faire très attention de bien s'isoler de la masse quand on soude dans des endroits humides, ou sur un plancher métallique ou des grilles métalliques, principalement dans les positions assis ou couché pour lesquelles une grande partie du corps peut être en contact avec la masse.
  - c. Maintenir le porte-électrode, la pince de masse, le câble de soudage et la machine à souder en bon et sûr état de fonctionnement.
  - d. Ne jamais plonger le porte-électrode dans l'eau pour le refroidir.
  - e. Ne jamais toucher simultanément les parties sous tension des porte-électrodes connectés à deux machines à souder parce que la tension entre les deux pinces peut être le total de la tension à vide des deux machines.
  - f. Si on utilise la machine à souder comme une source de courant pour soudage semi-automatique, ces précautions pour le porte-électrode s'appliquent aussi au pistolet de soudage.
2. Dans le cas de travail au dessus du niveau du sol, se protéger contre les chutes dans le cas où on recoit un choc. Ne jamais enrouler le câble-électrode autour de n'importe quelle partie du corps.
3. Un coup d'arc peut être plus sévère qu'un coup de soliel, donc:
  - a. Utiliser un bon masque avec un verre filtrant approprié ainsi qu'un verre blanc afin de se protéger les yeux du rayonnement de l'arc et des projections quand on soude ou quand on regarde l'arc.
  - b. Porter des vêtements convenables afin de protéger la peau de soudeur et des aides contre le rayonnement de l'arc.
  - c. Protéger l'autre personnel travaillant à proximité au soudage à l'aide d'écrans appropriés et non-inflammables.
4. Des gouttes de laitier en fusion sont émises de l'arc de soudage. Se protéger avec des vêtements de protection libres de l'huile, tels que les gants en cuir, chemise épaisse, pantalons sans revers, et chaussures montantes.
5. Toujours porter des lunettes de sécurité dans la zone de soudage. Utiliser des lunettes avec écrans latéraux dans les zones où l'on pique le laitier.

6. Eloigner les matériaux inflammables ou les recouvrir afin de prévenir tout risque d'incendie dû aux étincelles.
7. Quand on ne soude pas, poser la pince à un endroit isolé de la masse. Un court-circuit accidentel peut provoquer un échauffement et un risque d'incendie.
8. S'assurer que la masse est connectée le plus près possible de la zone de travail qu'il est pratique de le faire. Si on place la masse sur la charpente de la construction ou d'autres endroits éloignés de la zone de travail, on augmente le risque de voir passer le courant de soudage par les chaînes de levage, câbles de grue, ou autres circuits. Cela peut provoquer des risques d'incendie ou d'échauffement des chaînes et des câbles jusqu'à ce qu'ils se rompent.
9. Assurer une ventilation suffisante dans la zone de soudage. Ceci est particulièrement important pour le soudage de tôles galvanisées plombées, ou cadmiées ou tout autre métal qui produit des fumeés toxiques.
10. Ne pas souder en présence de vapeurs de chlore provenant d'opérations de dégraissage, nettoyage ou pistolage. La chaleur ou les rayons de l'arc peuvent réagir avec les vapeurs du solvant pour produire du phosgène (gas fortement toxique) ou autres produits irritants.
11. Pour obtenir de plus amples renseignements sur la sûreté, voir le code "Code for safety in welding and cutting" CSA Standard W 117.2-1974.

## PRÉCAUTIONS DE SÛRETÉ POUR LES MACHINES À SOUDER À TRANSFORMATEUR ET À REDRESSEUR

1. Relier à la terre le chassis du poste conformément au code de l'électricité et aux recommandations du fabricant. Le dispositif de montage ou la pièce à souder doit être branché à une bonne mise à la terre.
2. Autant que possible, l'installation et l'entretien du poste seront effectués par un électricien qualifié.
3. Avant de faire des travaux à l'intérieur de poste, la débrancher à l'interrupteur à la boîte de fusibles.
4. Garder tous les couvercles et dispositifs de sûreté à leur place.

Mar. '93

### ELECTROMAGNETIC COMPATIBILITY (EMC)

#### Conformance

Products displaying the CE mark are in conformity with European Community Council Directive of 3 May 1989 on the approximation of the laws of the Member States relating to electromagnetic compatibility (89/336/EEC). It was manufactured in conformity with a national standard that implements a harmonized standard: **EN 60974-10** Electromagnetic Compatibility (EMC) Product Standard for Arc Welding Equipment. It is for use with other Lincoln Electric equipment. It is designed for industrial and professional use.

#### Introduction

All electrical equipment generates small amounts of electromagnetic emission. Electrical emission may be transmitted through power lines or radiated through space, similar to a radio transmitter. When emissions are received by other equipment, electrical interference may result. Electrical emissions may affect many kinds of electrical equipment; other nearby welding equipment, radio and TV reception, numerical controlled machines, telephone systems, computers, etc. Be aware that interference may result and extra precautions may be required when a welding power source is used in a domestic establishment.

#### Installation and Use

The user is responsible for installing and using the welding equipment according to the manufacturer's instructions. If electromagnetic disturbances are detected then it shall be the responsibility of the user of the welding equipment to resolve the situation with the technical assistance of the manufacturer. In some cases this remedial action may be as simple as earthing (grounding) the welding circuit, see Note. In other cases it could involve constructing an electromagnetic screen enclosing the power source and the work complete with associated input filters. In all cases electromagnetic disturbances must be reduced to the point where they are no longer troublesome.

Note: The welding circuit may or may not be earthed for safety reasons according to national codes. Changing the earthing arrangements should only be authorized by a person who is competent to assess whether the changes will increase the risk of injury, e.g., by allowing parallel welding current return paths which may damage the earth circuits of other equipment.

#### Assessment of Area

Before installing welding equipment the user shall make an assessment of potential electromagnetic problems in the surrounding area. The following shall be taken into account:

- a) other supply cables, control cables, signaling and telephone cables; above, below and adjacent to the welding equipment;
- b) radio and television transmitters and receivers;
- c) computer and other control equipment;
- d) safety critical equipment, e.g., guarding of industrial equipment;
- e) the health of the people around, e.g., the use of pacemakers and hearing aids;
- f) equipment used for calibration or measurement;
- g) the immunity of other equipment in the environment. The user shall ensure that other equipment being used in the environment is compatible. This may require additional protection measures;
- h) the time of day that welding or other activities are to be carried out.

3-1-96H

L10093

### ELECTROMAGNETIC COMPATIBILITY (EMC)

The size of the surrounding area to be considered will depend on the structure of the building and other activities that are taking place. The surrounding area may extend beyond the boundaries of the premises.

#### Methods of Reducing Emissions

##### Mains Supply

Welding equipment should be connected to the mains supply according to the manufacturer's recommendations. If interference occurs, it may be necessary to take additional precautions such as filtering of the mains supply. Consideration should be given to shielding the supply cable of permanently installed welding equipment, in metallic conduit or equivalent. Shielding should be electrically continuous throughout its length. The shielding should be connected to the welding power source so that good electrical contact is maintained between the conduit and the welding power source enclosure.

##### Maintenance of the Welding Equipment

The welding equipment should be routinely maintained according to the manufacturer's recommendations. All access and service doors and covers should be closed and properly fastened when the welding equipment is in operation. The welding equipment should not be modified in any way except for those changes and adjustments covered in the manufacturer's instructions. In particular, the spark gaps of arc striking and stabilizing devices should be adjusted and maintained according to the manufacturer's recommendations.

##### Welding Cables

The welding cables should be kept as short as possible and should be positioned close together, running at or close to the floor level.

##### Equipotential Bonding

Bonding of all metallic components in the welding installation and adjacent to it should be considered. However, metallic components bonded to the work piece will increase the risk that the operator could receive a shock by touching these metallic components and the electrode at the same time. The operator should be insulated from all such bonded metallic components.

##### Earthing of the Workpiece

Where the workpiece is not bonded to earth for electrical safety, not connected to earth because of its size and position, e.g., ships hull or building steelwork, a connection bonding the workpiece to earth may reduce emissions in some, but not all instances. Care should be taken to prevent the earthing of the workpiece increasing the risk of injury to users, or damage to other electrical equipment. Where necessary, the connection of the workpiece to earth should be made by a direct connection to the workpiece, but in some countries where direct connection is not permitted, the bonding should be achieved by suitable capacitance, selected according to national regulations.

##### Screening and Shielding

Selective screening and shielding of other cables and equipment in the surrounding area may alleviate problems of interference. Screening of the entire welding installation may be considered for special applications.<sup>1</sup>

---

<sup>1</sup> Portions of the preceding text are contained in **EN 60974-10:** "Electromagnetic Compatibility (EMC) product standard for arc welding equipment."

# Thank You

for selecting a **QUALITY** product by Lincoln Electric. We want you to take pride in operating this Lincoln Electric Company product ... as much pride as we have in bringing this product to you!

## CUSTOMER ASSISTANCE POLICY

The business of The Lincoln Electric Company is manufacturing and selling high quality welding equipment, consumables, and cutting equipment. Our challenge is to meet the needs of our customers and to exceed their expectations. On occasion, purchasers may ask Lincoln Electric for advice or information about their use of our products. We respond to our customers based on the best information in our possession at that time. Lincoln Electric is not in a position to warrant or guarantee such advice, and assumes no liability, with respect to such information or advice. We expressly disclaim any warranty of any kind, including any warranty of fitness for any customer's particular purpose, with respect to such information or advice. As a matter of practical consideration, we also cannot assume any responsibility for updating or correcting any such information or advice once it has been given, nor does the provision of information or advice create, expand or alter any warranty with respect to the sale of our products.

Lincoln Electric is a responsive manufacturer, but the selection and use of specific products sold by Lincoln Electric is solely within the control of, and remains the sole responsibility of the customer. Many variables beyond the control of Lincoln Electric affect the results obtained in applying these types of fabrication methods and service requirements.

Subject to Change – This information is accurate to the best of our knowledge at the time of printing. Please refer to [www.lincolnelectric.com](http://www.lincolnelectric.com) for any updated information.

## Please Examine Carton and Equipment For Damage Immediately

When this equipment is shipped, title passes to the purchaser upon receipt by the carrier. Consequently, Claims for material damaged in shipment must be made by the purchaser against the transportation company at the time the shipment is received.

Please record your equipment identification information below for future reference. This information can be found on your machine nameplate.

Product \_\_\_\_\_

Model Number \_\_\_\_\_

Code Number or Date Code \_\_\_\_\_

Serial Number \_\_\_\_\_

Date Purchased \_\_\_\_\_

Where Purchased \_\_\_\_\_

Whenever you request replacement parts or information on this equipment, always supply the information you have recorded above. The code number is especially important when identifying the correct replacement parts.

## On-Line Product Registration

- Register your machine with Lincoln Electric either via fax or over the Internet.
  - For faxing: Complete the form on the back of the warranty statement included in the literature packet accompanying this machine and fax the form per the instructions printed on it.
  - For On-Line Registration: Go to our **WEB SITE at [www.lincolnelectric.com](http://www.lincolnelectric.com)**. Choose "Quick Links" and then "Product Registration". Please complete the form and submit your registration.

**Read this Operators Manual completely** before attempting to use this equipment. Save this manual and keep it handy for quick reference. Pay particular attention to the safety instructions we have provided for your protection. The level of seriousness to be applied to each is explained below:

### **WARNING**

This statement appears where the information **must** be followed **exactly** to avoid **serious personal injury or loss of life**.

### **CAUTION**

This statement appears where the information **must** be followed to avoid **minor personal injury or damage to this equipment**.



	Page
<b>Installation</b> .....	<b>Section A</b>
Technical Specifications .....	A-1
Safety Precautions .....	A-2
Select Suitable Location .....	A-2
Stacking .....	A-2
Tilting .....	A-2
Input Connections .....	A-2
Ground Connection .....	A-2
Input Power Connection .....	A-3
Engine Driven Connector .....	A-3
ARFU Auto-Restore Fuse .....	A-4
Output Connections .....	A-4
Stick Welding .....	A-4
Tig Welding .....	A-4
Replacement Quick Disconnect Plug (with Stick Electrode Cable) .....	A-5
<hr/>	
<b>Operation</b> .....	<b>Section B</b>
Safety Instructions .....	B-1
General Description .....	B-1
Welding Capability .....	B-1
Limitations .....	B-1
Controls and Operational Features .....	B-2, B-3
Rear Control Panel .....	B-3
Auto Adaptive Arc Force (with Stick Welding) .....	B-3
<hr/>	
<b>Accessories</b> .....	<b>Section C</b>
Optional Accessories and Compatible Equipment .....	C-1
Factory, Field Installed .....	C-1
<hr/>	
<b>Maintenance</b> .....	<b>Section D</b>
Safety Precautions .....	D-1
Input Filter Capacitor Discharge Procedure .....	D-1
Routine Maintenance .....	D-1
<hr/>	
<b>Troubleshooting</b> .....	<b>Section E</b>
How to Use Troubleshooting Guide .....	E-1
Troubleshooting Guide .....	E-2 thru E-4
<hr/>	
<b>Wiring Diagram</b> .....	<b>Section F</b>
<hr/>	
<b>Parts Pages</b> .....	<b>P-559</b>

## TECHNICAL SPECIFICATION V155-S

<b>INPUT - SINGLE PHASE ONLY</b>				
Input Voltages / 50 /60 Hz.	Max. Input Current at rated Output		Input Power at Rated Output	
	100%	30%	100%	30%
120Vac ± 10%	25A	34 A	2.2kw	3.0kw
230Vac ± 10%	23A	33 A	3.0kw	5.0kw
<b>RATED OUTPUT</b>				
Duty Cycle	Output Amps	Output Volts	Input Circuit	
100%	75A (Stick) 105A (TIG)	23.0 Vdc 14.2 Vdc	120 Vac	
	100A (Stick) 100A (TIG)	24.0 Vdc 14.0 Vdc	230 Vac	
30%	100A (Stick) 130A (TIG)	24.0 Vdc 15.2 Vdc	120 Vac	
	145A (Stick) 155A (TIG)	25.8 Vdc 16.2 Vdc	230 Vac	
<b>OUTPUT</b>				
Output Current Range	Maximum Open Circuit Voltage		Type of Output	
5-155 Amps	75 Volts Max.		DC	
<b>RECOMMENDED INPUT WIRE AND FUSE SIZES FOR MAXIMUM RATED OUTPUT</b>				
INPUT VOLTAGE / FREQUENCY (HZ)	TYPE S, SO ST, STO, OR EXTRA HARD USAGE INPUT CORD AWG		MAXIMUM TIME-DELAY CIRCUIT BREAKER OR FUSE SIZE (AMPS)	
230/60 120/60	3 Conductor, 12 AWG		30	
<b>PHYSICAL DIMENSIONS</b>				
Height	Width	Depth	Weight	
11.3 288 mm	6.2 in. 158 mm	15.4in. 392 mm	Approx. 14.7lbs. 6.7 kgs.	
<b>TEMPERATURE RANGES</b>				
OPERATING TEMPERATURE RANGE		STORAGE TEMPERATURE RANGE		
-10°C to +40°C		-25°C to +55°C		

V155-S



Read entire installation section before starting installation.

## SAFETY PRECAUTIONS

### ⚠ WARNING



**ELECTRIC SHOCK can kill.**

- Only qualified personnel should perform this installation.
- Disconnect input power by removing plug from receptacle before working inside V155-S. Allow machine to sit for 5 minutes minimum to allow the power capacitors to discharge before working inside this equipment.

- Insulate yourself from the work and ground.
- Always wear dry insulating gloves.
- Always connect the V155-S to a power supply grounded according to the National Electrical Code and local codes.

## SELECT SUITABLE LOCATION

This machine can operate in harsh environments. However, it is important that simple preventative measures are followed to assure long life and reliable operation:

- Do not use this machine for pipe thawing.
- This machine must be located where there is free circulation of clean air without restrictions for air movement to and from the air vents. Do not cover the machine with paper, cloth or rags when switched on.
- Dirt and dust that can be drawn into the machine should be kept to a minimum.
- This machine has a protection rating of IP23. Keep it dry when possible and do not place it on wet ground or in puddles.
- Locate the machine away from radio controlled machinery. Normal operation may adversely affect the operation of nearby radio controlled machinery, which may result in injury or equipment damage. Read the section on electromagnetic compatibility in this manual.
- Do not operate in areas with an ambient temperature greater than 40°C.

## STACKING

The Invertec V155-S cannot be stacked.

## TILTING

Place the machine directly on a secure, level surface. Do not place or operate this machine on a surface with an incline greater than 15° from horizontal. The machine may topple over if this procedure is not followed.

## INPUT CONNECTIONS

### ⚠ WARNING



**ELECTRIC SHOCK can kill.**

- Have a qualified electrician install and service this equipment.
- Disconnect input power by removing plug from receptacle before working inside V155-S. Allow machine to sit for 5 minutes minimum to allow the power capacitors to discharge before working inside this equipment.
- Do not touch electrically live parts.

## GROUND CONNECTION

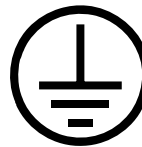

The frame of the welder must be grounded. A ground terminal marked with the symbol is located on the under panel for this purpose. See your local and national electrical codes for proper grounding methods.

### ⚠ CAUTION

A grounding conductor is supplied in the input cord, it is important that the supply receptacle ground is connected.

### ⚠ WARNING

This installation should be performed by a qualified electrician to ensure correct connections of the leads to the plug spades.

- The electrical system must be made by skilled technicians with the specific professional and technical qualifications and in compliance with the regulations in force in the country where the equipment is installed.
- The welding power source supply cable is provided with a green or yellow/green wire that must **ALWAYS** be earthed. This green or yellow/green wire must **NEVER** be used with other voltage conductors.

- Install only plugs that confirm with safety regulations.

## INPUT POWER CONNECTION

Check the input voltage, phase, and frequency supplied to this machine before turning it on. The allowable input voltage is indicated in the technical specification section of this manual and on the rating plate of the machine. Be sure that the machine is grounded.

Make sure the power available at the input connection is adequate for normal operation of the machine. The fuse rating and cable sizes are both indicated in the technical specification section of this manual.

Fuse the input circuit with time delay fuses marked "D" or delay type<sup>1</sup> circuit breakers. Using fuses or circuit breakers smaller than recommended may result in "nuisance" shut-offs from welder inrush currents even if not welding at high currents.

<sup>1</sup>Also called "inverse time" or "thermal/magnetic" circuit breakers. These circuit breakers have a delay in tripping action that decreases as the magnitude of the current increases.

The Invertec V155-S is recommended for use on an individual branch circuit.

### 120V INPUT

The rated output of the V155-S is available when connected to a 30A branch circuit. When connected to a branch circuit with lower ampacity, lower welding current and duty cycle must be used. An output guide is provided below. The values are approximate and must be adjusted downward if the fuse or circuit breaker trips off. Other loads on the circuit and fuse/circuit breaker characteristics will affect the available output. Do not exceed these welding conditions: (See Table A.1)

The Invertec V155-S is provided with a 120/230V cable, 6.6ft.(2m) in length, with a 15Amp 5-15P plug molded onto the cord.

The V155-S is supplied with an additional 20A plug that can replace the 15A plug to achieve higher output. To install the supplied 20A plug:

Connect the white (neutral) wire under terminal clamp with silver screw, and black (hot) wire under terminal clamp with brass screw. Connect green wire under terminal clamp with green screw.

TABLE A.1

120V Input		BRANCH Output Current					
		Stick			TIG		
Plug Rating	Branch Rating	10% Duty Cycle	30% Duty Cycle	100% Duty Cycle	10% Duty Cycle	30% Duty Cycle	100% Duty Cycle
15 Amp	15 Amp	65A	55A	45A	100A	85A	75A
15 Amp	20 Amp	75A	70A	60A	110A	100A	95A
20 Amp	20 Amp	85A	75A	60A	130A	130A	95A

## ⚠ WARNING

**Failure to wire as instructed may cause personal injury or damage to equipment. To be installed or checked by an electrician or qualified person only.**

### 230V INPUT

To achieve the full output capacity of the V155-S, 230VAC inputs should be used. The change over is accomplished by replacing the 120VAC plug with a 30 Amp 230VAC plug (NEMA 6-30P).

### ATTACHMENT PLUG

In all cases, the green or green/yellow grounding wire must be connected to the grounding pin of the plug, usually identified by a green screw.

All attachment plugs must comply with the Standard for Attachment Plugs and Receptacles, UL498.

The product is considered acceptable for use only when an attachment plug as specified is properly attached to the supply cord.

The Invertec V155-S will auto reconnect to either 120V or 230V supplies.

### ENGINE DRIVEN GENERATOR

The machine is designed to operate on engine driven generators as long as the auxiliary can supply adequate voltage, frequency and power as indicated in the "Technical Specification" Installation Section of this manual. The auxiliary supply of the generator must also meet the following conditions:

- Vac peak voltage: below 205V (for 115Vac input) or 410V (for 230Vac input).
- Vac frequency: in the range of 50 and 60 Hertz.
- RMS voltage of the AC waveform: 115Vac or 230Vac  $\pm$  10%

It is important to check these conditions because many engine driven generators produce high voltage spikes. Operation of this machine with engine driven generators not conforming to these conditions is not recommended and may damage the machine.

V155-S



## ARFU (Auto-Restore Fuse)

The dual input voltage machine is provided with the ARFU device. It operates only when the input is connected to the 120Vac mains and protects from input overcurrent. When active, the "Thermal LED" lights (see "Controls and Operational Features" in the Operation Section).

Note: The ARFU device operates independently from the machine's duty-cycle.

## OUTPUT CONNECTIONS

A quick disconnect system using Twist-Mate™ cable plugs is used for the welding cable connections. Refer to the following sections for more information on connecting the machine for operation of stick welding (MMA) or TIG welding.

### ⚠ WARNING



**ELECTRIC SHOCK can kill.**

- Keep the electrode holder and cable insulation in good condition.
- Do not touch electrically live parts or electrode with skin or wet clothing.
- Insulate yourself from work and ground.
- Turn the input line Switch on the Invertec V155-S "off" before connecting or disconnecting output cables or other equipment.

## STICK WELDING (MMA)

First determine the proper electrode polarity for the electrode to be used. Consult the electrode data for this information. Then connect the output cables to the output terminals of the machine for the selected polarity. Shown here is the connection method for DC(+) welding. (See Figure A.1)

Connect the electrode cable to the (+) terminal and the work clamp to the (-) terminal. Insert the connector with the key lining up with the keyway and rotate approximately 1/4 turn clockwise. Do not over tighten.

For DC(-) welding, switch the cable connections at the machine so that the electrode cable is connected to (-) and the work clamp is connected to (+).

FIGURE A.1

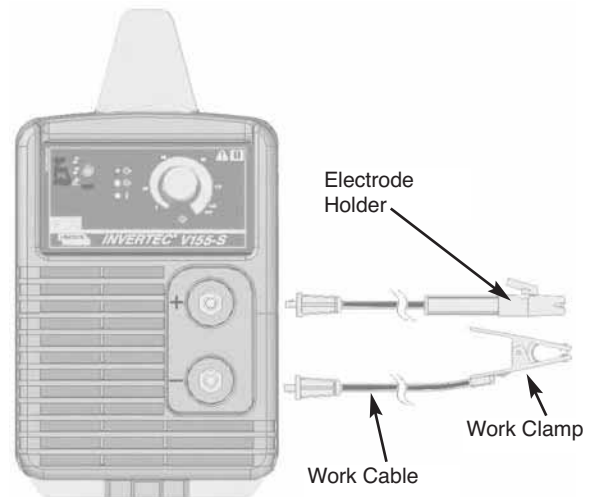

## TIG WELDING

This machine does not have a built in Gas Solenoid so a one piece gas valve TIG Torch is required. A K960-2 Twist-mate TIG Torch adapter is also required. Refer to the accessories section for more information about TIG Torches and required Twist-mate adapter. Most TIG welding is done with DC(-) polarity shown here. If DC(+) polarity is necessary switch the cable connections at the machine. (See Figure A.2)

Connect the torch cable to the (-) terminal of the machine and the work clamp to the (+) terminal. Insert the connector with the key lining up with the keyway and rotate approximately 1/4 turn clockwise. Do not over tighten. Finally, connect the Twist-mate adapter gas hose to the gas regulator on the cylinder of gas to be used.

FIGURE A.2

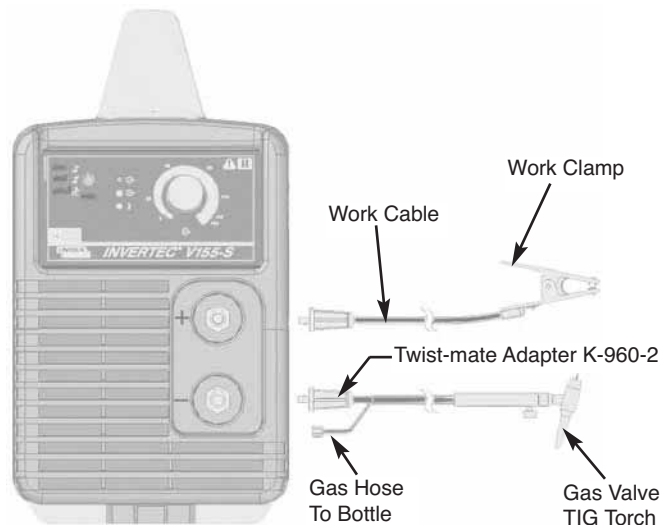

## REPLACEMENT QUICK DISCONNECT PLUG (FOR STICK ELECTRODE CABLE)

The V155-S comes with a factory assembled stick electrode holder, cable and Twist-mate adapter plug. If a replacement cable is ever needed a K852-25 Twist-mate plug will be needed.

To attach the K852-25 plug:

1. Cut off welding cable lug, if present.
2. Remove .75 in. (19mm) of welding cable insulation.
3. Slide rubber boot onto cable end. The boot end may be trimmed to match the cable diameter. Use soap or other nonpetroleum-based lubricant to help slide the boot over the cable, if needed.

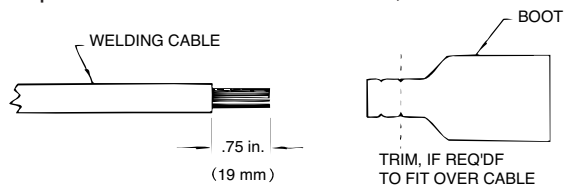

4. Cut 45-50% of the copper strands back 1/4" (6 mm).

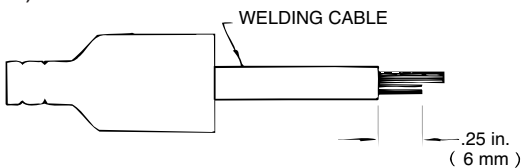

5. Fold copper strands over cut strands and insert into ferrule.

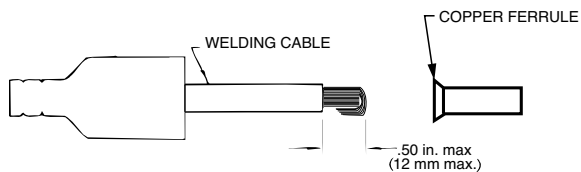

6. Slide the copper ferrule into the brass plug.

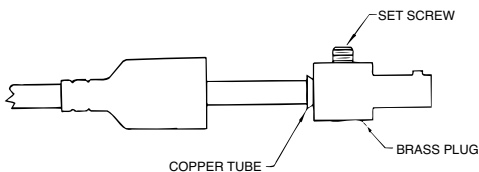

7. Tighten set screw to collapse copper tube. Screw must apply pressure against welding cable. The top of the set screw will be well below the surface of the brass plug after tightening.

Read and understand this entire section before operating your machine.

## SAFETY INSTRUCTIONS

### WARNING



#### **ELECTRIC SHOCK can kill.**

- Do not touch electrically live parts such as output terminals or internal wiring.
- Insulate yourself from the work and ground.
- Always wear dry insulating gloves.



#### **FUMES AND GASES can be dangerous.**

- Keep your head out of fumes.
- Use ventilation or exhaust to remove fumes from breathing zone.

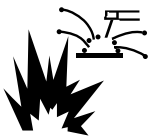

#### **WELDING, CUTTING and GOUGING SPARKS can cause fire or explosion**

- Keep flammable material away.
- Do not weld, cut or gouge on containers that have held combustibles.



#### **ARC RAYS can burn.**

- Wear eye, ear and body protection.

Only qualified personnel should operate this equipment. Observe all safety information throughout this manual.

## GENERAL DESCRIPTION

The Invertec V155-S is an industrial 155 amp arc welding power source which utilizes single phase input power, to produce constant current output. The welding response of this Invertec has been optimized for stick (SMAW) and Touch Start TIG (GTAW). The unit is ideal for industrial applications where portability is important.

The Invertec V155-S is recommended for stick welding with such popular electrodes as Fleetweld 35, Fleetweld 37, Fleetweld 180 and LH 78. It features automatic arc control to adjust the arc force, hot start and anti sticking. The machine also features soft and crisp modes.

The Invertec V155-S performs DC Touch Start Tig Starting with excellent results.

## WELDING CAPABILITY

The Invertec V155-S is rated at 155 amps, 16.2 volts, at 30% duty cycle on a ten minute basis. It is capable of higher duty cycles at lower output currents<sup>(1)</sup>. If the duty cycle is exceeded, a thermal protector will shut off the output until the machine cools. See Technical Specifications in the Installation Section for other rated outputs.

The Invertec V155-S is recommended for stick welding with such popular electrodes as Fleetweld® 35, Fleetweld 37, Fleetweld 180 and Jet-LH 78 MR. It features adjustable arc control to adjust the arc force and start.

## LIMITATIONS



The V155-S is not recommended for pipe thawing.

<sup>(1)</sup> Refer to Technical Specifications in the Installation Section for other ratings.

**CONTROLS AND OPERATIONAL FEATURES**

**1. Output Current Knob:**  Potentiometer used to set the output current used during welding, from 5A to 155A.

**2. Welding Mode Switch:** With three positions, controls the welding mode of the machine: two for Stick welding (Soft and Crisp) and one for Lift TIG welding.

- Soft Stick:  For a welding with a low spatter presence.
- Crisp Stick:  For an aggressive welding, with an increased Arc stability.
- Lift TIG:  When the mode switch is in the Lift TIG position, the stick welding functions are disabled and the machine is ready for Lift TIG welding. Lift TIG is a method of starting a TIG weld by first pressing the TIG torch electrode on the work piece in order to create a low current short circuit. Then, the electrode is lifted from the work piece to start the TIG arc.



**3. Thermal LED:**  This indicator will turn on when the machine is overheated and the output has been disabled. This normally occurs when the duty cycle of the machine has been exceeded. Leave the machine on to allow the internal components to cool. When the indicator turns off, normal operation is again possible.

If the Yellow LED illuminates, and the Red and Green LED's blink on and off alternately, the unit is unable to cool itself adequately. Check to make sure the fan is not obstructed and the fan is operating properly. Prior to resuming normal operation, the unit must be turned off and turned back on to reset this error condition.

** WARNING**

If blinking, this LED indicates that the input voltage is out of 120 or 230Vac ranges.

**4. Power On/Off & OUTPUT LEDs:** These LEDs (one green and one red) operates as described in the table below:

LED status		FUNCTION
Green	Red	
ON	OFF	The machine is turned ON.   ON condition: The machine is at idle (no-welding time) and OCV is present.
OFF	ON	The machine is turned ON.   On condition: Presence of welding current at the output leads.  This permanent LED condition, showed at idle (no-welding time), indicates a machine damage.
OFF	OFF	The machine is turned OFF and/or the input cord could be disconnected from the mains.  ERROR condition: With the Power Switch turned ON and the input cord properly connected to a "live" main supply, this LED condition indicates a machine damage.
ON	ON	ERROR condition: This LED condition indicates a machine damage.

**FIGURE B.1**

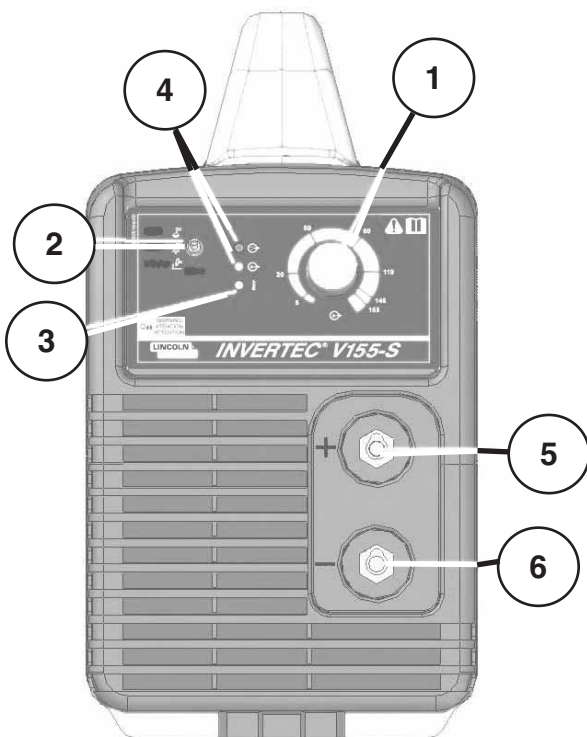

- 1. Output Current Knob
- 2. Welding Mode Switch
- 3. Thermal LED
- 4. Power On/Off and Output LED's
- 5. Positive Quick Disconnect
- 6. Negative Quick Disconnect



**5. Positive Quick Disconnect:** Positive output connector for the welding circuit.

**6. Negative Quick Disconnect:** Negative output connector for the welding circuit.

### REAR CONTROL PANEL

(See Figure B.2)

**7. Power Switch:** It turns ON / OFF the input power to the machine.

**8. Input cable:** This machine is provided with a plugged input cord. Connect it to the mains.

**9. Fan:** This machine has a F.A.N. (Fan As Needed) circuitry inside: the fan is automatically turned ON or OFF. This feature reduces the amount of dirt which can be drawn inside the machine and reduces power consumption. The F.A.N. operates in different modes, it depends by the selected weld:

- **Stick mode:** When the machine is turned ON the fan will turn ON. The fan will continue to run whenever the machine is welding. If the machine doesn't weld for more than five minutes, the fan will turn OFF.
- **TIG modes:** When the machine is turned ON the fan is OFF. The fan will turn ON only when a weld is started and it will continue to run whenever the machine is welding. If the machine doesn't weld for more than five minutes, the fan will turn OFF.

### AUTO ADAPTIVE ARC FORCE (WITH STICK WELDING)

The Auto Adaptive Arc Force function is activated during stick welding. This function increases temporary the output current, used to clear intermittent connections between the electrode and the weld puddle that occur during stick welding.

This is an active control feature that guarantees the best arrangement between the arc stability and spatter presence. The feature "Auto Adaptive Arc Force" has instead of a fixed or manual regulation, an automatic and multilevel setting: its intensity depends by the output voltage and is controlled by the micro-processor.

The control determines the amount of current to apply to break the metal drop that is being transferred from the electrode to the workpiece to guarantee the arc stability, but not too high to minimize spatter around the welding puddle. That means:

- Electrode / workpiece sticking prevention, also with low current values.
- Spatters reduction.

The welding operations are simplified and the welded joints looks better, also if not brushed after the welding.

This feature is available in both the Soft Stick and Crisp Stick operating modes. The Crisp Stick feature also increases the Hot Start action, facilitating the arc striking.

With the Stick welding are also enabled the following features:

- **Hot Start:** This is a temporary increase in the initial welding current. This helps ignite the arc quickly and reliably.
- **Anti-Sticking:** This is a function that decreases the output current of the machine to a low level when the operator makes an error and sticks the electrode to the work piece. This decrease in current allows the operator to remove the electrode from the electrode holder without creating large sparks that can damage the electrode holder.

FIGURE B.2

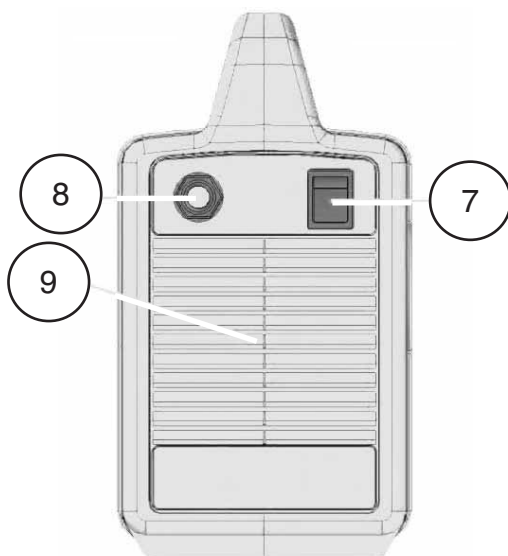

## OPTIONAL ACCESSORIES AND COMPATIBLE EQUIPMENT

### Factory Installed

Electrical Holder and Cable Assembly  
Work Cable and Clamp  
Strap Packet  
Instruction Manual

### Field Installed

**PTA-17V TIG Torch** - 150 Amp air-cooled compact and durable Tig Torch with integral gas valve for gas control at the torch. The following 1-piece cable torches can be used with a K960-2 adapter:

- K1782-6 (12.50 Ft.) 1-Piece Cable
- K1782-8 (25.0 Ft.) 1-Piece Cable

**PTA-9FV TIG Torch** - 125 Amp Gas Valve flexible head torch:

- K1781-7 (25.0 Ft.) 1-Piece Cable

**PTA-17FV TIG Torch** - 150 Amp Gas Valve flexible head torch:

- K1782-11 (25.0 Ft.) 1-Piece Cable
- K1782-13 (12.5 Ft.) 1-Piece Ultra Flex Cable

**K960-2-TIG Torch Adapter** - for connection of PTA-17V torches (1-piece cable) to power sources without gas passing through the Twist Mate connection.

## CABLE PLUGS

**K852-25** - Cable Plug Kit attaches to welding cable to provide quick disconnect from machine.

**TIG Torch Parts Kits** - Parts kits are available for the PTA-9FV and PTA-17 TIG torch. These kits include back cap, collets, collet bodies, nozzles and tungstens.

**Order KP508** for PTA-17 torches

**Order KP507** for PTA-9 torches

See publication E12.150 for parts kits breakdown.

**Cut Length Consumables** - TIG welding filler metals are available for welding stainless steel, mild steel, aluminum and copper alloys. See publication C9.10.

**SAFETY PRECAUTIONS****WARNING**

**ELECTRIC SHOCK** can kill.

- Have an electrician install and service this equipment.
- Turn the input power off at the fuse box, disconnect supply lines and allow machine to sit for five minutes minimum to allow the power capacitors to discharge before working inside this equipment.
- Do not touch electrically hot parts.

**WARNING**

Do not open this machine and do not introduce anything into its openings. Power supply must be disconnected from the machine before each maintenance and service. After each repair, perform proper tests to ensure safety.

**CAUTION**

Power supply must be disconnected from the machine before each maintenance and service. Always use gloves in compliance with the safety standards.

**INPUT FILTER CAPACITOR DISCHARGE PROCEDURE****WARNING**

For any maintenance or repair operations it is recommended to contact the nearest technical service center or Lincoln Electric. Maintenance or repairs performed by unauthorized service centers or personnel will null and void the manufacturers warranty.

**WARNING**

The machine has internal capacitors which are charged to a high voltage during power-on conditions. This voltage is dangerous and must be discharged before the machine can be serviced. Discharging is done automatically by the machine each time the power is switched off. However, you must allow the machine to sit for at least 5 minutes to allow time for the process to take place.

**ROUTINE MAINTENANCE**

The frequency of the maintenance operations may vary in accordance with the working environment. Any noticeable damage should be reported immediately.

- Check cables and connections integrity. Replace, if necessary.
- Clean the power source inside by means of low - pressure compressed air.
- Keep the machine clean. Use a soft dry cloth to clean the external case, especially the airflow inlet / outlet louvers.

V155-S

## HOW TO USE TROUBLESHOOTING GUIDE

### WARNING

Service and Repair should only be performed by Lincoln Electric Factory Trained Personnel. Unauthorized repairs performed on this equipment may result in danger to the technician and machine operator and will invalidate your factory warranty. For your safety and to avoid Electrical Shock, please observe all safety notes and precautions detailed throughout this manual.

This Troubleshooting Guide is provided to help you locate and repair possible machine malfunctions. Simply follow the three-step procedure listed below.

#### **Step 1. LOCATE PROBLEM (SYMPTOM).**

Look under the column labeled “PROBLEM (SYMPTOMS)”. This column describes possible symptoms that the machine may exhibit. Find the listing that best describes the symptom that the machine is exhibiting.

#### **Step 2. POSSIBLE CAUSE.**

The second column labeled “POSSIBLE CAUSE” lists the obvious external possibilities that may contribute to the machine symptom.

#### **Step 3. RECOMMENDED COURSE OF ACTION**

This column provides a course of action for the Possible Cause, generally it states to contact your local Lincoln Authorized Field Service Facility.

If you do not understand or are unable to perform the Recommended Course of Action safely, contact your local Lincoln Authorized Field Service Facility.

### CAUTION

If for any reason you do not understand the test procedures or are unable to perform the tests/repairs safely, contact your **Local Lincoln Authorized Field Service Facility** for technical troubleshooting assistance before you proceed.

V155-S

**LINCOLN**<sup>®</sup>  
**ELECTRIC**

Observe all Safety Guidelines detailed throughout this manual

PROBLEMS (SYMPTOMS)	POSSIBLE CAUSE	RECOMMENDED COURSE OF ACTION
<b>PROBLEMS IN STICK WELDING</b>		
Excessive spatter	1. Long arc 2. High current	If all recommended possible areas of misadjustment have been checked and the problem persists, <b>Contact your local Lincoln Authorized Field Service Facility.</b>
Craters	1. Fast movement of the electrode away from piece.	
Inclusions	1. Poor cleanliness or distribution of the Welding passes. 2. Improper movement of the electrode.	
Insufficient penetration	1. High progression speed. 2. Welding current too low. 3. Narrow chamfering.	
Sticking	1. Arc too short. 2. Current too low.	
Porosity	1. Humidity in electrode. 2. Long arc.	
Cracks	1. Current too high. 2. Dirty materials. 3. Hydrogen in weld (present on electrode coating).	

**⚠ CAUTION**

If for any reason you do not understand the test procedures or are unable to perform the tests/repairs safely, contact your **Local Lincoln Authorized Field Service Facility** for technical troubleshooting assistance before you proceed.

Observe all Safety Guidelines detailed throughout this manual

PROBLEMS (SYMPTOMS)	POSSIBLE CAUSE	RECOMMENDED COURSE OF ACTION
<b>PROBLEMS IN TIG WELDING</b>		
Oxidation	<ol style="list-style-type: none"> <li>1. Insufficient gas.</li> <li>2. No protection on the back side.</li> </ol>	<p>If all recommended possible areas of misadjustment have been checked and the problem persists, <b>Contact your local Lincoln Authorized Field Service Facility.</b></p>
Tungsten inclusions	<ol style="list-style-type: none"> <li>1. Incorrect electrode sharpening.</li> <li>2. Electrode too small.</li> <li>3. Operating failure (contact of the tip with the workpiece).</li> </ol>	
Porosity	<ol style="list-style-type: none"> <li>1. Dirt on the edges.</li> <li>2. Dirt on the filler material.</li> <li>3. Excessive travel speed.</li> <li>4. Current intensity too low.</li> </ol>	
Hot cracking	<ol style="list-style-type: none"> <li>1. Unsuitable filler material.</li> <li>2. High heat supply.</li> <li>3. Dirty materials.</li> </ol>	

**⚠ CAUTION**

If for any reason you do not understand the test procedures or are unable to perform the tests/repairs safely, contact your **Local Lincoln Authorized Field Service Facility** for technical troubleshooting assistance before you proceed.

If for any reason you do not understand the test procedures or are unable to perform the tests/repairs safely, contact your **Local Lincoln Authorized Field Service Facility** for technical troubleshooting assistance before you proceed.

V155-S



Observe all Safety Guidelines detailed throughout this manual

PROBLEMS (SYMPTOMS)	POSSIBLE CAUSE	RECOMMENDED COURSE OF ACTION
<b>ELECTRICAL FAILURES</b>		
Machine fails to come on (Power LED off)	<ol style="list-style-type: none"> <li>1. No Input Voltage.</li> <li>2. Faulty supply plug or cable.</li> <li>3. Internal fuse tripped. Allow time to Auto reset.</li> </ol>	<p>If all recommended possible areas of misadjustment have been checked and the problem persists, <b>Contact your local Lincoln Authorized Field Service Facility.</b></p>
Thermal overload (Thermal LED on)	<ol style="list-style-type: none"> <li>1. Unit has been operated beyond its capacity rating.</li> <li>2. Airflow through machine is restricted or fan has failed.</li> </ol>	

 **CAUTION**

If for any reason you do not understand the test procedures or are unable to perform the tests/repairs safely, contact your **Local Lincoln Authorized Field Service Facility** for technical troubleshooting assistance before you proceed.

V155-S



WIRING DIAGRAM FOR CODES 11326; 11327

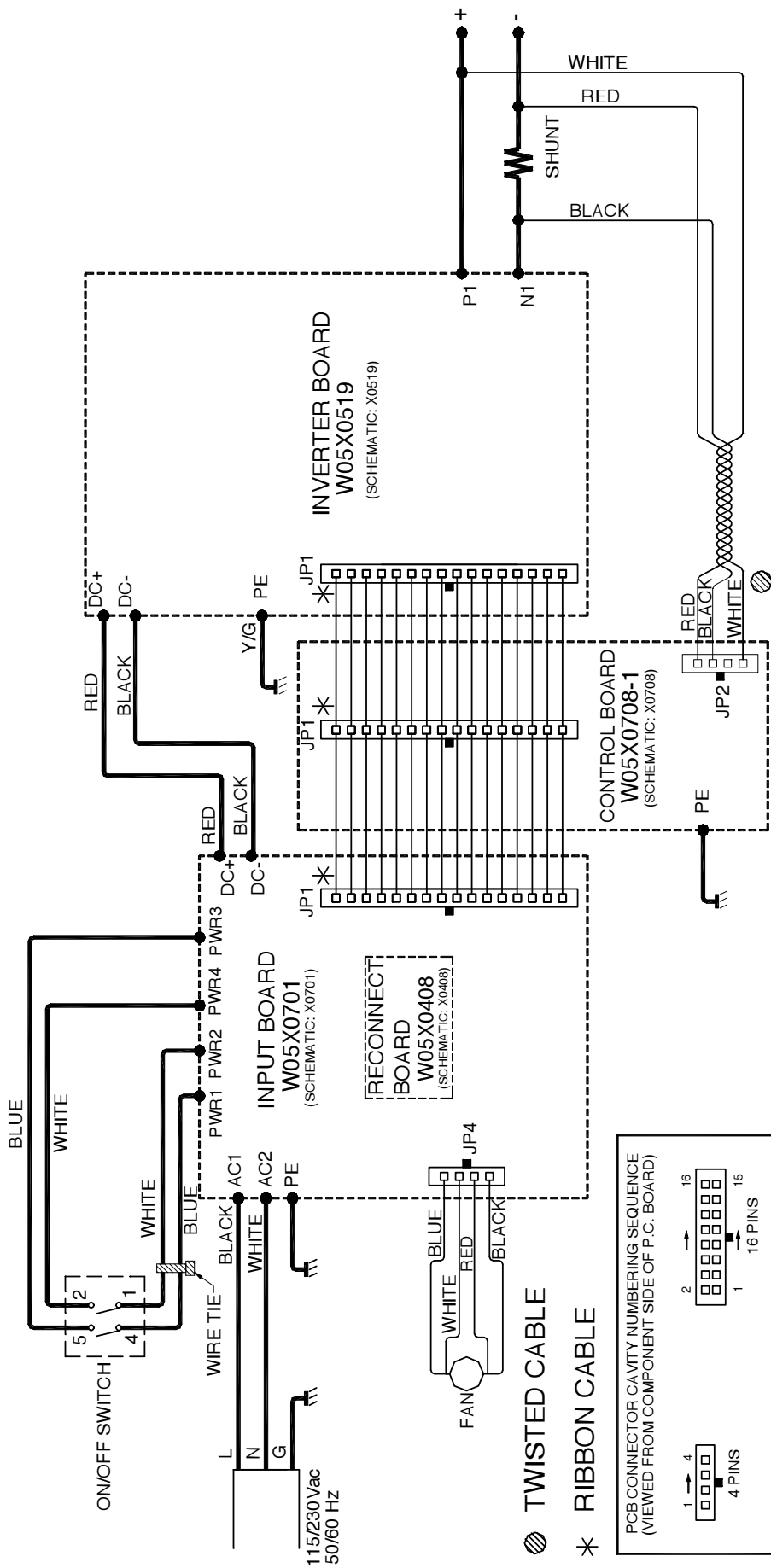

NOTE: This diagram is for reference only. It may not be accurate for all machines covered by this manual. The specific diagram for a particular code is pasted inside the machine on one of the enclosure panels. If the diagram is illegible, write to the Service Department for a replacement. Give the equipment code number.



<b>WARNING</b>	<ul style="list-style-type: none"> <li>● Do not touch electrically live parts or electrode with skin or wet clothing.</li> <li>● Insulate yourself from work and ground.</li> </ul>	<ul style="list-style-type: none"> <li>● Keep flammable materials away.</li> </ul>	<ul style="list-style-type: none"> <li>● Wear eye, ear and body protection.</li> </ul>
Spanish <b>AVISO DE PRECAUCION</b>	<ul style="list-style-type: none"> <li>● No toque las partes o los electrodos bajo carga con la piel o ropa mojada.</li> <li>● Aíslese del trabajo y de la tierra.</li> </ul>	<ul style="list-style-type: none"> <li>● Mantenga el material combustible fuera del área de trabajo.</li> </ul>	<ul style="list-style-type: none"> <li>● Protéjase los ojos, los oídos y el cuerpo.</li> </ul>
French <b>ATTENTION</b>	<ul style="list-style-type: none"> <li>● Ne laissez ni la peau ni des vêtements mouillés entrer en contact avec des pièces sous tension.</li> <li>● Isolez-vous du travail et de la terre.</li> </ul>	<ul style="list-style-type: none"> <li>● Gardez à l'écart de tout matériel inflammable.</li> </ul>	<ul style="list-style-type: none"> <li>● Protégez vos yeux, vos oreilles et votre corps.</li> </ul>
German <b>WARNUNG</b>	<ul style="list-style-type: none"> <li>● Berühren Sie keine stromführenden Teile oder Elektroden mit Ihrem Körper oder feuchter Kleidung!</li> <li>● Isolieren Sie sich von den Elektroden und dem Erdboden!</li> </ul>	<ul style="list-style-type: none"> <li>● Entfernen Sie brennbares Material!</li> </ul>	<ul style="list-style-type: none"> <li>● Tragen Sie Augen-, Ohren- und Körperschutz!</li> </ul>
Portuguese <b>ATENÇÃO</b>	<ul style="list-style-type: none"> <li>● Não toque partes elétricas e electrodos com a pele ou roupa molhada.</li> <li>● Isole-se da peça e terra.</li> </ul>	<ul style="list-style-type: none"> <li>● Mantenha inflamáveis bem guardados.</li> </ul>	<ul style="list-style-type: none"> <li>● Use proteção para a vista, ouvido e corpo.</li> </ul>
Japanese <b>注意事項</b>	<ul style="list-style-type: none"> <li>● 通電中の電気部品、又は溶材にヒフやぬれた布で触れないこと。</li> <li>● 施工物やアースから身体が絶縁されている様にして下さい。</li> </ul>	<ul style="list-style-type: none"> <li>● 燃えやすいものの側での溶接作業は絶対にしてはなりません。</li> </ul>	<ul style="list-style-type: none"> <li>● 目、耳及び身体に保護具をして下さい。</li> </ul>
Chinese <b>警告</b>	<ul style="list-style-type: none"> <li>● 皮肤或湿衣物切勿接触带电部件及焊条。</li> <li>● 使你自已与地面和工作件绝缘。</li> </ul>	<ul style="list-style-type: none"> <li>● 把一切易燃物品移离工作场所。</li> </ul>	<ul style="list-style-type: none"> <li>● 佩戴眼、耳及身体劳动保护用具。</li> </ul>
Korean <b>위험</b>	<ul style="list-style-type: none"> <li>● 전도체나 용접봉을 젖은 형갑 또는 피부로 절대 접촉치 마십시오.</li> <li>● 모재와 접지를 접촉치 마십시오.</li> </ul>	<ul style="list-style-type: none"> <li>● 인화성 물질을 접근시키지 마십시오.</li> </ul>	<ul style="list-style-type: none"> <li>● 눈, 귀와 몸에 보호장구를 착용하십시오.</li> </ul>
Arabic <b>تحذير</b>	<ul style="list-style-type: none"> <li>● لا تلمس الاجزاء التي يسري فيها التيار الكهربائي أو الألكترود بجند الجسم أو بالملابس المبللة بالماء.</li> <li>● ضع عازلا على جسمك خلال العمل.</li> </ul>	<ul style="list-style-type: none"> <li>● ضع المواد القابلة للاشتعال في مكان بعيد.</li> </ul>	<ul style="list-style-type: none"> <li>● ضع أدوات وملابس واقية على عينيك وأذنيك وجسمك.</li> </ul>

**READ AND UNDERSTAND THE MANUFACTURER'S INSTRUCTION FOR THIS EQUIPMENT AND THE CONSUMABLES TO BE USED AND FOLLOW YOUR EMPLOYER'S SAFETY PRACTICES.**

**SE RECOMIENDA LEER Y ENTENDER LAS INSTRUCCIONES DEL FABRICANTE PARA EL USO DE ESTE EQUIPO Y LOS CONSUMIBLES QUE VA A UTILIZAR, SIGA LAS MEDIDAS DE SEGURIDAD DE SU SUPERVISOR.**

**LISEZ ET COMPRENEZ LES INSTRUCTIONS DU FABRICANT EN CE QUI REGARDE CET EQUIPMENT ET LES PRODUITS A ETRE EMPLOYES ET SUIVEZ LES PROCEDURES DE SECURITE DE VOTRE EMPLOYEUR.**

**LESEN SIE UND BEFOLGEN SIE DIE BETRIEBSANLEITUNG DER ANLAGE UND DEN ELEKTRODENEINSATZ DES HERSTELLERS. DIE UNFALLVERHÜTUNGSVORSCHRIFTEN DES ARBEITGEBERS SIND EBENFALLS ZU BEACHTEN.**

			
<ul style="list-style-type: none"> <li>● Keep your head out of fumes.</li> <li>● Use ventilation or exhaust to remove fumes from breathing zone.</li> </ul>	<ul style="list-style-type: none"> <li>● Turn power off before servicing.</li> </ul>	<ul style="list-style-type: none"> <li>● Do not operate with panel open or guards off.</li> </ul>	<b>WARNING</b>
<ul style="list-style-type: none"> <li>● Los humos fuera de la zona de respiración.</li> <li>● Mantenga la cabeza fuera de los humos. Utilice ventilación o aspiración para gases.</li> </ul>	<ul style="list-style-type: none"> <li>● Desconectar el cable de alimentación de poder de la máquina antes de iniciar cualquier servicio.</li> </ul>	<ul style="list-style-type: none"> <li>● No operar con panel abierto o guardas quitadas.</li> </ul>	Spanish <b>AVISO DE PRECAUCION</b>
<ul style="list-style-type: none"> <li>● Gardez la tête à l'écart des fumées.</li> <li>● Utilisez un ventilateur ou un aspirateur pour ôter les fumées des zones de travail.</li> </ul>	<ul style="list-style-type: none"> <li>● Débranchez le courant avant l'entretien.</li> </ul>	<ul style="list-style-type: none"> <li>● N'opérez pas avec les panneaux ouverts ou avec les dispositifs de protection enlevés.</li> </ul>	French <b>ATTENTION</b>
<ul style="list-style-type: none"> <li>● Vermeiden Sie das Einatmen von Schweißrauch!</li> <li>● Sorgen Sie für gute Be- und Entlüftung des Arbeitsplatzes!</li> </ul>	<ul style="list-style-type: none"> <li>● Strom vor Wartungsarbeiten abschalten! (Netzstrom völlig öffnen; Maschine anhalten!)</li> </ul>	<ul style="list-style-type: none"> <li>● Anlage nie ohne Schutzgehäuse oder Innenschutzverkleidung in Betrieb setzen!</li> </ul>	German <b>WARNUNG</b>
<ul style="list-style-type: none"> <li>● Mantenha seu rosto da fumaça.</li> <li>● Use ventilação e exaustão para remover fumo da zona respiratória.</li> </ul>	<ul style="list-style-type: none"> <li>● Não opere com as tampas removidas.</li> <li>● Desligue a corrente antes de fazer serviço.</li> <li>● Não toque as partes elétricas nuas.</li> </ul>	<ul style="list-style-type: none"> <li>● Mantenha-se afastado das partes moventes.</li> <li>● Não opere com os painéis abertos ou guardas removidas.</li> </ul>	Portuguese <b>ATENÇÃO</b>
<ul style="list-style-type: none"> <li>● ヒュームから頭を離すようにして下さい。</li> <li>● 換気や排煙に十分留意して下さい。</li> </ul>	<ul style="list-style-type: none"> <li>● メンテナンス・サービスに取りかかる際には、まず電源スイッチを必ず切して下さい。</li> </ul>	<ul style="list-style-type: none"> <li>● パネルやカバーを取り外したまま機械操作をしないで下さい。</li> </ul>	Japanese <b>注意事項</b>
<ul style="list-style-type: none"> <li>● 頭部遠離煙霧。</li> <li>● 在呼吸區使用通風或排風器除煙。</li> </ul>	<ul style="list-style-type: none"> <li>● 維修前切斷電源。</li> </ul>	<ul style="list-style-type: none"> <li>● 儀表板打開或沒有安全罩時不準作業。</li> </ul>	Chinese <b>警告</b>
<ul style="list-style-type: none"> <li>● 얼굴로부터 용접가스를 멀리하십시오.</li> <li>● 호흡지역으로부터 용접가스를 제거하기 위해 가스제거기나 통풍기를 사용하십시오.</li> </ul>	<ul style="list-style-type: none"> <li>● 보수전에 전원을 차단하십시오.</li> </ul>	<ul style="list-style-type: none"> <li>● 판넬이 열린 상태로 작동치 마십시오.</li> </ul>	Korean <b>위험</b>
<ul style="list-style-type: none"> <li>● ابعء رأسك بعيداً عن الدخان.</li> <li>● استعمل التهوية أو جهاز ضغط الدخان للخارج لكي تبعد الدخان عن المنطقة التي تتنفس فيها.</li> </ul>	<ul style="list-style-type: none"> <li>● اقطع التيار الكهربائي قبل القيام بأية صيانة.</li> </ul>	<ul style="list-style-type: none"> <li>● لا تشغيل هذا الجهاز اذا كانت الاغطية الحديدية الواقية ليست عليه.</li> </ul>	Arabic <b>تحذير</b>

**LEIA E COMPREENDA AS INSTRUÇÕES DO FABRICANTE PARA ESTE EQUIPAMENTO E AS PARTES DE USO, E SIGA AS PRÁTICAS DE SEGURANÇA DO EMPREGADOR.**

使う機械や溶材のメーカーの指示書をよく読み、まず理解して下さい。そして貴社の安全規定に従って下さい。

請詳細閱讀並理解製造廠提供的說明以及應該使用的銀焊材料，並請遵守貴方的有閣勞動保護規定。

이 제품에 동봉된 작업지침서를 숙지하시고 귀사의 작업자 안전수칙을 준수하시기 바랍니다.

اقرأ بتمعن وافهم تعليمات المصنع المنتج لهذه المعدات والمواد قبل استعمالها واتبع تعليمات الوقاية لصاحب العمل.



• World's Leader in Welding and Cutting Products •

• Sales and Service through Subsidiaries and Distributors Worldwide •

Cleveland, Ohio 44117-1199 U.S.A. TEL: 216.481.8100 FAX: 216.486.1751 WEB SITE: [www.lincolnelectric.com](http://www.lincolnelectric.com)