

Operator's Manual

APEX[®] 3 SERIES MIG PENDANT

ORIGINAL INSTRUCTIONS

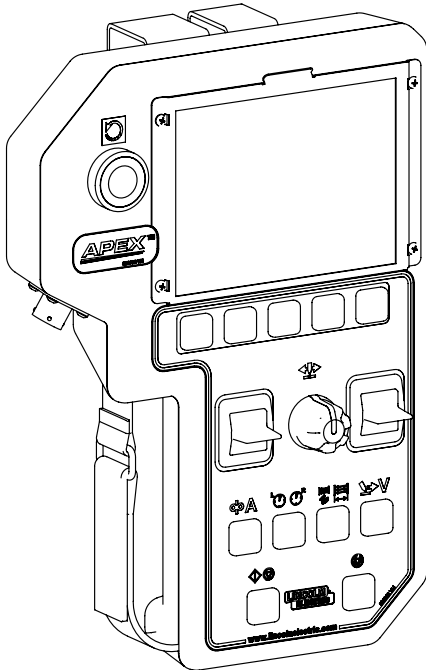

For use with machines having Code Numbers:
70313, 12833



Register your machine:
www.lincolnelectric.com/register
Authorized Service and Distributor Locator:
www.lincolnelectric.com/locator

Need Help? In the USA and Canada, call
1.800.770.0063 to talk to a Service Representative.

Hours of Operation:
7:00 AM to 5:00 PM (PT) Mon. thru Fri.

Save for future reference

Date Purchased

Code: (ex: 10859)

Serial: (ex: U1060512345)

After hours?
Use "Ask the Experts" at lincolnelectric.com
A Lincoln Service Representative will contact you
no later than the following business day.

For Service outside the USA and Canada, please call
1.619.628.1022 or e-mail us at:
orbitalsupport@lincolnelectric.com

THANK YOU FOR SELECTING A QUALITY PRODUCT BY LINCOLN ELECTRIC.

PLEASE EXAMINE CARTON AND EQUIPMENT FOR DAMAGE IMMEDIATELY

When this equipment is shipped, title passes to the purchaser upon receipt by the carrier. Consequently, Claims for material damaged in shipment must be made by the purchaser against the transportation company at the time the shipment is received.

SAFETY DEPENDS ON YOU

Lincoln arc welding and cutting equipment is designed and built with safety in mind. However, your overall safety can be increased by proper installation ... and thoughtful operation on your part.

DO NOT INSTALL, OPERATE OR REPAIR THIS EQUIPMENT WITHOUT READING THIS MANUAL AND THE SAFETY PRECAUTIONS CONTAINED THROUGHOUT. And, most importantly, think before you act and be careful.



WARNING

This statement appears where the information must be followed exactly to avoid serious personal injury or loss of life.



CAUTION

This statement appears where the information must be followed to avoid minor personal injury or damage to this equipment.



KEEP YOUR HEAD OUT OF THE FUMES.

DON'T get too close to the arc. Use corrective lenses if necessary to stay a reasonable distance away from the arc.

READ and obey the Material Safety Data Sheet (MSDS) and the warning label that appears on all containers of welding materials.

USE ENOUGH VENTILATION or exhaust at the arc, or both, to keep the fumes and gases from your breathing zone and the general area.

IN A LARGE ROOM OR OUTDOORS, natural ventilation may be adequate if you keep your head out of the fumes (See below).

USE NATURAL DRAFTS or fans to keep the fumes away from your face.

If you develop unusual symptoms, see your supervisor. Perhaps the welding atmosphere and ventilation system should be checked.

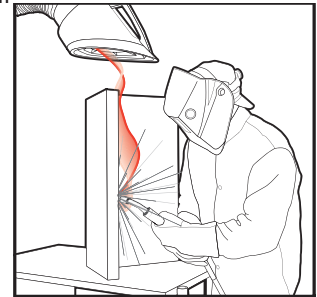

WEAR CORRECT EYE, EAR & BODY PROTECTION

PROTECT your eyes and face with welding helmet properly fitted and with proper grade of filter plate (See ANSI Z49.1).

PROTECT your body from welding spatter and arc flash with protective clothing including woolen clothing, flame-proof apron and gloves, leather leggings, and high boots.

PROTECT others from splatter, flash, and glare with protective screens or barriers.

IN SOME AREAS, protection from noise may be appropriate.

BE SURE protective equipment is in good condition.

Also, wear safety glasses in work area **AT ALL TIMES**.



SPECIAL SITUATIONS

DO NOT WELD OR CUT containers or materials which previously had been in contact with hazardous substances unless they are properly cleaned. This is extremely dangerous.

DO NOT WELD OR CUT painted or plated parts unless special precautions with ventilation have been taken. They can release highly toxic fumes or gases.



Additional precautionary measures

PROTECT compressed gas cylinders from excessive heat, mechanical shocks, and arcs; fasten cylinders so they cannot fall.

BE SURE cylinders are never grounded or part of an electrical circuit.

REMOVE all potential fire hazards from welding area.

ALWAYS HAVE FIRE FIGHTING EQUIPMENT READY FOR IMMEDIATE USE AND KNOW HOW TO USE IT.



SECTION A: WARNINGS



CALIFORNIA PROPOSITION 65 WARNINGS

Diesel Engines

Diesel engine exhaust and some of its constituents are known to the State of California to cause cancer, birth defects, and other reproductive harm.

Gasoline Engines

The engine exhaust from this product contains chemicals known to the State of California to cause cancer, birth defects, or other reproductive harm.



ARC WELDING CAN BE HAZARDOUS. PROTECT YOURSELF AND OTHERS FROM POSSIBLE SERIOUS INJURY OR DEATH. KEEP CHILDREN AWAY. PACEMAKER WEARERS SHOULD CONSULT WITH THEIR DOCTOR BEFORE OPERATING.

Read and understand the following safety highlights. For additional safety information, it is strongly recommended that you purchase a copy of "Safety in Welding & Cutting - ANSI Standard Z49.1" from the American Welding Society, P.O. Box 351040, Miami, Florida 33135 or CSA Standard W117.2-1974. A Free copy of "Arc Welding Safety" booklet E205 is available from the Lincoln Electric Company, 22801 St. Clair Avenue, Cleveland, Ohio 44117-1199.

BE SURE THAT ALL INSTALLATION, OPERATION, MAINTENANCE AND REPAIR PROCEDURES ARE PERFORMED ONLY BY QUALIFIED INDIVIDUALS.



FOR ENGINE POWERED EQUIPMENT.

- 1.a. Turn the engine off before troubleshooting and maintenance work unless the maintenance work requires it to be running. 
- 1.b. Operate engines in open, well-ventilated areas or vent the engine exhaust fumes outdoors.
- 1.c. Do not add the fuel near an open flame welding arc or when the engine is running. Stop the engine and allow it to cool before refueling to prevent spilled fuel from vaporizing on contact with hot engine parts and igniting. Do not spill fuel when filling tank. If fuel is spilled, wipe it up and do not start engine until fumes have been eliminated. 

- 1.d. Keep all equipment safety guards, covers and devices in position and in good repair. Keep hands, hair, clothing and tools away from V-belts, gears, fans and all other moving parts when starting, operating or repairing equipment.



- 1.e. In some cases it may be necessary to remove safety guards to perform required maintenance. Remove guards only when necessary and replace them when the maintenance requiring their removal is complete. Always use the greatest care when working near moving parts.
- 1.f. Do not put your hands near the engine fan. Do not attempt to override the governor or idler by pushing on the throttle control rods while the engine is running.
- 1.g. To prevent accidentally starting gasoline engines while turning the engine or welding generator during maintenance work, disconnect the spark plug wires, distributor cap or magneto wire as appropriate.
- 1.h. To avoid scalding, do not remove the radiator pressure cap when the engine is hot.



ELECTRIC AND MAGNETIC FIELDS MAY BE DANGEROUS

- 2.a. Electric current flowing through any conductor causes localized Electric and Magnetic Fields (EMF). Welding current creates EMF fields around welding cables and welding machines. 
- 2.b. EMF fields may interfere with some pacemakers, and welders having a pacemaker should consult their physician before welding.
- 2.c. Exposure to EMF fields in welding may have other health effects which are now not known.
- 2.d. All welders should use the following procedures in order to minimize exposure to EMF fields from the welding circuit:
 - 2.d.1. Route the electrode and work cables together - Secure them with tape when possible.
 - 2.d.2. Never coil the electrode lead around your body.
 - 2.d.3. Do not place your body between the electrode and work cables. If the electrode cable is on your right side, the work cable should also be on your right side.
 - 2.d.4. Connect the work cable to the workpiece as close as possible to the area being welded.
 - 2.d.5. Do not work next to welding power source.



ELECTRIC SHOCK CAN KILL.



- 3.a. The electrode and work (or ground) circuits are electrically “hot” when the welder is on. Do not touch these “hot” parts with your bare skin or wet clothing. Wear dry, hole-free gloves to insulate hands.
- 3.b. Insulate yourself from work and ground using dry insulation. Make certain the insulation is large enough to cover your full area of physical contact with work and ground.

In addition to the normal safety precautions, if welding must be performed under electrically hazardous conditions (in damp locations or while wearing wet clothing; on metal structures such as floors, gratings or scaffolds; when in cramped positions such as sitting, kneeling or lying, if there is a high risk of unavoidable or accidental contact with the workpiece or ground) use the following equipment:

- Semiautomatic DC Constant Voltage (Wire) Welder.
 - DC Manual (Stick) Welder.
 - AC Welder with Reduced Voltage Control.
- 3.c. In semiautomatic or automatic wire welding, the electrode, electrode reel, welding head, nozzle or semiautomatic welding gun are also electrically “hot”.
 - 3.d. Always be sure the work cable makes a good electrical connection with the metal being welded. The connection should be as close as possible to the area being welded.
 - 3.e. Ground the work or metal to be welded to a good electrical (earth) ground.
 - 3.f. Maintain the electrode holder, work clamp, welding cable and welding machine in good, safe operating condition. Replace damaged insulation.
 - 3.g. Never dip the electrode in water for cooling.
 - 3.h. Never simultaneously touch electrically “hot” parts of electrode holders connected to two welders because voltage between the two can be the total of the open circuit voltage of both welders.
 - 3.i. When working above floor level, use a safety belt to protect yourself from a fall should you get a shock.
 - 3.j. Also see Items 6.c. and 8.



ARC RAYS CAN BURN.



- 4.a. Use a shield with the proper filter and cover plates to protect your eyes from sparks and the rays of the arc when welding or observing open arc welding. Headshield and filter lens should conform to ANSI Z87.1 standards.
- 4.b. Use suitable clothing made from durable flame-resistant material to protect your skin and that of your helpers from the arc rays.
- 4.c. Protect other nearby personnel with suitable, non-flammable screening and/or warn them not to watch the arc nor expose themselves to the arc rays or to hot spatter or metal.



FUMES AND GASES CAN BE DANGEROUS.



- 5.a. Welding may produce fumes and gases hazardous to health. Avoid breathing these fumes and gases. When welding, keep your head out of the fume. Use enough ventilation and/or exhaust at the arc to keep fumes and gases away from the breathing zone. **When welding with electrodes which require special ventilation such as stainless or hard facing (see instructions on container or MSDS) or on lead or cadmium plated steel and other metals or coatings which produce highly toxic fumes, keep exposure as low as possible and within applicable OSHA PEL and ACGIH TLV limits using local exhaust or mechanical ventilation. In confined spaces or in some circumstances, outdoors, a respirator may be required. Additional precautions are also required when welding on galvanized steel.**
5. b. The operation of welding fume control equipment is affected by various factors including proper use and positioning of the equipment, maintenance of the equipment and the specific welding procedure and application involved. Worker exposure level should be checked upon installation and periodically thereafter to be certain it is within applicable OSHA PEL and ACGIH TLV limits.
- 5.c. Do not weld in locations near chlorinated hydrocarbon vapors coming from degreasing, cleaning or spraying operations. The heat and rays of the arc can react with solvent vapors to form phosgene, a highly toxic gas, and other irritating products.
- 5.d. Shielding gases used for arc welding can displace air and cause injury or death. Always use enough ventilation, especially in confined areas, to insure breathing air is safe.
- 5.e. Read and understand the manufacturer's instructions for this equipment and the consumables to be used, including the material safety data sheet (MSDS) and follow your employer's safety practices. MSDS forms are available from your welding distributor or from the manufacturer.
- 5.f. Also see item 1.b.



WELDING AND CUTTING SPARKS CAN CAUSE FIRE OR EXPLOSION.

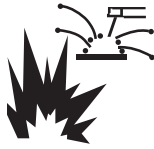

- 6.a. Remove fire hazards from the welding area. If this is not possible, cover them to prevent the welding sparks from starting a fire. Remember that welding sparks and hot materials from welding can easily go through small cracks and openings to adjacent areas. Avoid welding near hydraulic lines. Have a fire extinguisher readily available.
- 6.b. Where compressed gases are to be used at the job site, special precautions should be used to prevent hazardous situations. Refer to "Safety in Welding and Cutting" (ANSI Standard Z49.1) and the operating information for the equipment being used.
- 6.c. When not welding, make certain no part of the electrode circuit is touching the work or ground. Accidental contact can cause overheating and create a fire hazard.
- 6.d. Do not heat, cut or weld tanks, drums or containers until the proper steps have been taken to insure that such procedures will not cause flammable or toxic vapors from substances inside. They can cause an explosion even though they have been "cleaned". For information, purchase "Recommended Safe Practices for the Preparation for Welding and Cutting of Containers and Piping That Have Held Hazardous Substances", AWS F4.1 from the American Welding Society (see address above).
- 6.e. Vent hollow castings or containers before heating, cutting or welding. They may explode.
- 6.f. Sparks and spatter are thrown from the welding arc. Wear oil free protective garments such as leather gloves, heavy shirt, cuffless trousers, high shoes and a cap over your hair. Wear ear plugs when welding out of position or in confined places. Always wear safety glasses with side shields when in a welding area.
- 6.g. Connect the work cable to the work as close to the welding area as practical. Work cables connected to the building framework or other locations away from the welding area increase the possibility of the welding current passing through lifting chains, crane cables or other alternate circuits. This can create fire hazards or overheat lifting chains or cables until they fail.
- 6.h. Also see item 1.c.
- 6.i. Read and follow NFPA 51B "Standard for Fire Prevention During Welding, Cutting and Other Hot Work", available from NFPA, 1 Batterymarch Park, PO box 9101, Quincy, Ma 022690-9101.
- 6.j. Do not use a welding power source for pipe thawing.



CYLINDER MAY EXPLODE IF DAMAGED.



- 7.a. Use only compressed gas cylinders containing the correct shielding gas for the process used and properly operating regulators designed for the gas and pressure used. All hoses, fittings, etc. should be suitable for the application and maintained in good condition.
- 7.b. Always keep cylinders in an upright position securely chained to an undercarriage or fixed support.
- 7.c. Cylinders should be located:
 - Away from areas where they may be struck or subjected to physical damage.
 - A safe distance from arc welding or cutting operations and any other source of heat, sparks, or flame.
- 7.d. Never allow the electrode, electrode holder or any other electrically "hot" parts to touch a cylinder.
- 7.e. Keep your head and face away from the cylinder valve outlet when opening the cylinder valve.
- 7.f. Valve protection caps should always be in place and hand tight except when the cylinder is in use or connected for use.
- 7.g. Read and follow the instructions on compressed gas cylinders, associated equipment, and CGA publication P-1, "Precautions for Safe Handling of Compressed Gases in Cylinders," available from the Compressed Gas Association 1235 Jefferson Davis Highway, Arlington, VA 22202.



FOR ELECTRICALLY POWERED EQUIPMENT.



- 8.a. Turn off input power using the disconnect switch at the fuse box before working on the equipment.
- 8.b. Install equipment in accordance with the U.S. National Electrical Code, all local codes and the manufacturer's recommendations.
- 8.c. Ground the equipment in accordance with the U.S. National Electrical Code and the manufacturer's recommendations.

Refer to <http://www.lincolnelectric.com/safety> for additional safety information.

ELECTROMAGNETIC COMPATIBILITY (EMC)

CONFORMANCE

Products displaying the CE mark are in conformity with European Community Council Directive of 3 May 1989 on the approximation of the laws of the Member States relating to electromagnetic compatibility (89/336/EEC). It was manufactured in conformity with a national standard that implements a harmonized standard: EN 60974-10

Electromagnetic Compatibility (EMC) Product Standard for Arc Welding Equipment. It is for use with other Lincoln Electric equipment. It is designed for industrial and professional use.

INTRODUCTION

All electrical equipment generates small amounts of electromagnetic emission. Electrical emission may be transmitted through power lines or radiated through space, similar to a radio transmitter. When emissions are received by other equipment, electrical interference may result. Electrical emissions may affect many kinds of electrical equipment; other nearby welding equipment, radio and TV reception, numerical controlled machines, telephone systems, computers, etc. Be aware that interference may result and extra precautions may be required when a welding power source is used in a domestic establishment.

INSTALLATION AND USE

The user is responsible for installing and using the welding equipment according to the manufacturer's instructions. If electromagnetic disturbances are detected then it shall be the responsibility of the user of the welding equipment to resolve the situation with the technical assistance of the manufacturer. In some cases this remedial action may be as simple as earthing (grounding) the welding circuit, see Note. In other cases it could involve construction of an electromagnetic screen enclosing the power source and the work complete with associated input filters. In all cases electromagnetic disturbances must be reduced to the point where they are no longer troublesome.

Note: The welding circuit may or may not be earthed for safety reasons according to national codes. Changing the earthing arrangements should only be authorized by a person who is competent to access whether the changes will increase the risk of injury, e.g., by allowing parallel welding current return paths which may damage the earth circuits of other equipment.

ASSESSMENT OF AREA

Before installing welding equipment the user shall make an assessment of potential electromagnetic problems in the surrounding area. The following shall be taken into account:

- a. other supply cables, control cables, signaling and telephone cables; above, below and adjacent to the welding equipment;
- b. radio and television transmitters and receivers;
- c. computer and other control equipment;
- d. safety critical equipment, e.g., guarding of industrial equipment;
- e. the health of the people around, e.g., the use of pacemakers and hearing aids;
- f. equipment used for calibration or measurement
- g. the immunity of other equipment in the environment. The user shall ensure that other equipment being used in the environment is compatible. This may require additional protection measures;
- h. the time of day that welding or other activities are to be carried out.

The size of the surrounding area to be considered will depend on the structure of the building and other activities that are taking place. The surrounding area may extend beyond the boundaries of the premises.

METHODS OF REDUCING EMISSIONS

Mains Supply

Welding equipment should be connected to the mains supply according to the manufacturer's recommendations. If interference occurs, it may be necessary to take additional precautions such as filtering of the mains supply. Consideration should be given to shielding the supply cable of permanently installed welding equipment, in metallic conduit or equivalent. Shielding should be electrically continuous throughout its length. The shielding should be connected to the welding power source so that good electrical contact is maintained between the conduit and the welding power source enclosure.

Maintenance of the Welding Equipment

The welding equipment should be routinely maintained according to the manufacturer's recommendations. All access and service doors and covers should be closed and properly fastened when the welding equipment is in operation. The welding equipment should not be modified in any way except for those changes and adjustments covered in the manufacturer's instructions. In particular, the spark gaps of arc striking and stabilizing devices should be adjusted and maintained according to the manufacturer's recommendations.

Welding Cables

The welding cables should be kept as short as possible and should be positioned close together, running at or close to floor level.

Equipotential Bonding

Bonding of all metallic components in the welding installation and adjacent to it should be considered. However, metallic components bonded to the work piece will increase the risk that the operator could receive a shock by touching these metallic components and the electrode at the same time. The operator should be insulated from all such bonded metallic components.

Earthing of the Workpiece

Where the workpiece is not bonded to earth for electrical safety, not connected to earth because of its size and position, e.g., ships hull or building steelwork, a connection bonding the workpiece to earth may reduce emissions in some, but not all instances. Care should be taken to prevent the earthing of the work piece increasing the risk of injury to users, or damage to other electrical equipment. Where necessary, the connection of the workpiece to earth should be made by a direct connection to the work piece, but in some countries where direct connection is not permitted, the bonding should be achieved by suitable capacitance, selected according to national regulations.

Screening and Shielding

Selective screening and shielding of other cables and equipment in the surrounding area may alleviate problems of interference. Screening of the entire welding installation may be considered for special applications.





































1 Portions of the preceding text are contained in EN 60974-10: "Electromagnetic Compatibility (EMC) product standard for arc welding equipment."

Safety	2
Symbols & Icons	9
Safety Precautions	10
Proper handling.....	10
Operation	10
Explanation of Welding Terms.....	10
System Start Up.....	B-1
Startup Screen.....	B-1
Pendant Operation.....	B-2
Button Actions.....	B-2
Selection Buttons.....	B-2
Navigation Controls.....	B-2
Menu Buttons.....	B-3
Control Buttons.....	B-3
Color Coding.....	B-3
Fast Movement.....	B-3
System Log In.....	B-4
Fast Movement.....	B-4
Log In Screen.....	B-5
Idle Screen.....	B-6
Menu Option Variables.....	B-6
Idle Screen Buttons.....	B-7
Idle Screen Test/Weld Modes.....	B-8
Weld Screen.....	B-9
Weld Screen Buttons.....	B-9
Test Screen.....	B-9
Test Screen Buttons.....	B-9
Jog Screen.....	B-10
Jog Buttons.....	B-11
Oscillation Screen.....	B-12
Oscillation Buttons.....	B-13
Setup Menu.....	B-14
Setup Screen Options.....	B-15
Track Setup.....	B-15
Track Type.....	B-15
Track Ring Size.....	B-15
Pipe Size.....	B-15
Heavy Wall Pipes.....	B-15
Positioner Setup.....	B-15
Travel Setup Screen.....	B-16
Travel Pattern.....	B-16
Process Setup Screen.....	B-17
Standard Process Options.....	B-17
Weave Process Options.....	B-17
Mode Select.....	B-18
List Mode Select.....	B-19
Advanced Process Setup.....	B-19
Advanced Options.....	B-19
Wave Controls.....	B-19
Height/Sensitivity Recommendations.....	B-19
Start Settings.....	B-20
End Settings.....	B-20

GMAW/FCAW Timing Diagram	B-21
Service Menu	B-22
Version.....	B-22
Motion	B-22
Faults.....	B-23
Settings	B-23
Input Test.....	B-23
How to Take a Snapshot	B-24
Users.....	B-25
Fast Movement.....	B-25
Adding Users.....	B-25
Deleting Users	B-26
Changing User Access.....	B-27
Log Out.....	B-27
Operator Log In	B-27
Increments Settings	B-28
Increment Options.....	B-28
Increment Reference	B-29
Programs	B-30
Fast Movement.....	B-30
Saving an Independent Pass.....	B-30
Saving a Program Base.....	B-31
Saving a Program Pass	B-31
Saving Program Updates	B-32
Hide Program Passes.....	B-33
Saving to a USB	B-33
Copy to/from USB.....	B-33
Deleting a Program.....	B-34
Deleting a Program Base.....	B-34
Loading a Program.....	B-34
Overwriting a Program	B-35
Standard Piping Schedule Chart.....	36
Wiring Diagram.....	37
Parts	38

Symbols & Icons

This list is a quick reference for all icons from the pendant and on the control unit.

	Users		Set Up/ Modes		Wire		Reboot		Insert
	Weld		Weld Time		Upslope / Start Settings		Process		Track Ring
	Test Mode		Reset Settings		Downslope / End Settings		Version		Track Ring Diameter
	Sector		Enter		Time		Motion		Pipe
	Trash/Delete		Voltage		Program		Return Home		Pipe Diameter
	Gas Purge Pre/Post Flow		Amperage		Volts		Trim		Log Out
	Save		Travel / Travel Setup		Speed		Left Dwell		Settings / Service Page
	Swap		Shift Case		Width		Right Dwell		Increment Unit Settings
	Gas		Advanced Settings		Next / Index		Travel Direction		Positioner
	ID Track		Water		Wire Feed Forward		Travel Direction		Wire / Wire Feed Speed
	OD Track		Steering / Oscillator		Wire Speed Reverse		Travel Direction		Previous / Index
	Flat Track		Wire Diam- eter		Pass		Travel Direction		Add User
	Direction		Delay		Amps		Details		Weave Type
	Manual Height		Torch/Auto Height		Oscillation Speed		Copy To		Constant Travel
	Exit		Oscillation		1,2,3... Mode Select		Cancel		Step Travel
	Oscillation Width		Weld Mode		Load		Okay		No Weave Travel
	Snapshot		Weld Head		Wire On		Faults		Settings

Safety Precautions

Read entire manual before installation or operation.



WARNING

ELECTRIC SHOCK CAN KILL

- Only qualified personnel should perform this installation.
- Turn the input power OFF at the disconnect switch or fuse box before working on this equipment turn off the input power to any other equipment connected to the welding system at the disconnect switch or fuse box before working on the equipment.
- Do not touch electrically hot parts.
- Always connect the power supply grounding lug to a proper safety (Earth) ground.



Proper handling

The APEX® 3 Series Pendant is designed to be turned on and off through the welding power supply. The pendant should be kept dry and sheltered from rain and snow. Do not place or drop the pendant on wet ground or in puddles. Always place the pendant on a sturdy, flat level surface when not in use and be sure to unplug it.

Keep hands away from weld head, wire feeder and other moving parts while in operation. Read this entire process and operations manual before using the equipment.

Only operate the system while on a firm level surface. Always verify that the system cart is secured in place before operating the system.

Keep hands away from weld head, wire feeder and other moving parts while in operation.



CAUTION

Never unplug or plug in control cables to the weld head while the system is powered on.

Verify that the system is properly grounded before beginning to weld.

Refer to the individual components manuals for additional instructions.

OPERATION

Explanation of Welding Terms

GMAW: Gas Metal Arc Welding

FCAW: Flux Cored Arc Welding

STT: Surface Tension Transfer

WFS: Wire Feed Speed

OSC: Oscillation

ACC: Automatic Current Control

AHC: Automatic Height Control

ID: Inside Diameter

OD: Outside Diameter

WFS: Wire Feed Speed

IPM: Inches per minute

CM/MIN: Centimeters per minute

Volts: Voltage

Amps: Amperage

System Start Up

Ensure all components are connected. Refer to the individual component manuals for full connection instructions.

Prior to beginning the weld, turn on the welding power supply. The system is designed to be turned on and off through the welding power supply.

Startup Screen

When the system is reset at the Power Wave®, the screen will display “Checking Network Connection... Calibrating System – **FIGURE 1 - Startup Screen**. This is a normal part of the initialization process.

Note: During the start up interval, the weld head goes through a self-calibration cycle. The system will not allow the user to log in until the calibration cycle has been completed.

When the system is fully calibrated, the user is presented with a log in screen – see **FIGURE 2 - Log In Screen**. Log in to begin use. See the next sections for pendant operation.

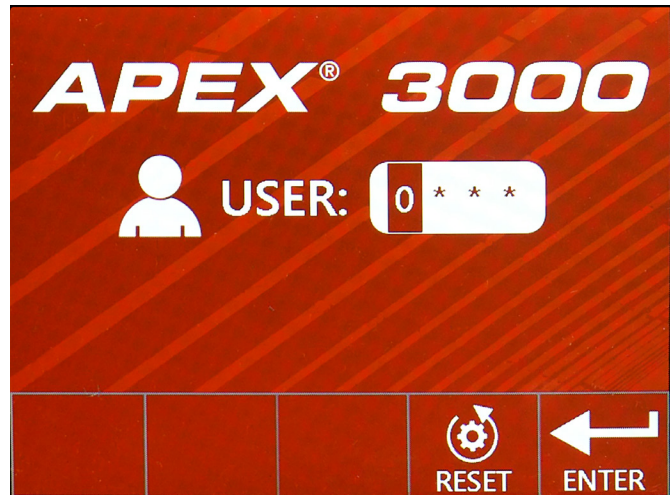

FIGURE 2 - Log In Screen



FIGURE 1 - Startup Screen

Pendant Operation

The APEX 3 Series Pendant is designed around full functionality and easy operator experience. The pendant's buttons serve multiple purposes, depending on the screen display. See **FIGURE 3 - Pendant Items on page B-3** – to review each button, knob and switch on the pendant.

Button Actions

Each of the buttons and toggles may perform differently depending on how the buttons are pressed. Listed below are the four types of button presses.

1. SHORT PRESS

A short press is a standard press that engages the button and is not held in place. Most operations are performed as a short press.

Example: Quickly pressing down button 7 will center the oscillator.

2. LONG PRESS

For some screens, holding a button down for a length of time exceeding two seconds signals the system to perform an alternate function.

Example: A long press of more than two seconds on button 7 will start the oscillation test mode on some screens.

3. HOLD

By pressing and holding down a button or toggle, the effects exhibited will continue or speed up.

Example: When pressing button 1 in the jog screen, gas will purge for three seconds. Holding down button 1 will cause the gas to continuously purge.

4. HOLD AND ROTATE

The steering knob also acts as a button. It can be pressed or rotated for different actions for some screens. It can also be held down and rotated for faster navigation.

Selection Buttons

Buttons 1 through 5 are selection buttons. Their functions change depending on the screen. In each screen there will be an icon just above the button to indicate its function. A short press enables, disables or selects the shown variable.

Navigation Controls

Items 6 through 8 control navigation. They function primarily for navigating through the menus and changing values while setting up the system.

Note: When welding, steering knob 7 functions only for steering or oscillation steering if oscillation is enabled.

6. LEFT TOGGLE (WHITE BORDER)

- **Short Press** – Navigates or changes the selected value (in this example, it will change the value in the left dwell box)
- **Hold** – Increases or decreases value / change speed on some screens

7. STEERING KNOB

- **Rotate** – Steers oscillation in and out or changes the selected variable
- **Short Press** – Centers the oscillation or moves to the next variable
- **Long Press** – Starts / Stops oscillation test (in idle mode only)
- **Hold & Rotate** – Fast navigation between selected variables

8. RIGHT TOGGLE (GRAY BORDER)

- **Short Press** – Navigates or changes the selected value (in this example, it will change the value in the right dwell box)
- **Hold** – Increases or decreases value / changes speed on some screens

Menu Buttons

Buttons 9 through 12 are the menu buttons. Pressing one of these buttons will bring up a menu while in the idle, test or welding screens.

9. WIRE FEED/AMPS

- **Short Press** – Wire Feed/Amps options
- **Long Press** – Navigates to the Jog Screen from the Idle Weld screen

10. DWELL

- **Short Press** – Dwell options
- **Long Press** – Navigates to the Oscillation Screen from the Idle Weld screen

11. OSCILLATION

- **Short Press** – Oscillation options
- **Long Press** – Navigates to the Oscillation Screen from the Idle Weld screen

12. TRAVEL/VOLTS

- **Short Press** - Travel/voltage options
- **Long Press** - Navigates to the jog screen from the idle weld screen

Control Buttons

Buttons 13 through 15 are the pendant control buttons. These buttons have specific purposes that typically do not change.

Note: The control buttons may be disabled in menu screens.

13. START/STOP

- **Short Press** – Start if idle, stop if welding, stop/start test weld when in test mode

14. SECTOR

- **Short Press** – Switches between sectors and changes passes (if available) on the Increments screen.

15. RESET –

- **Short Press** – Initiates a system reset

IMPORTANT! The reset button is not an emergency stop button. Power is still being applied to the system.

Color Coding

The menu buttons and toggles are color-coded. For example, the icons above button 9 are Wire Feed (white icon) and Amps (gray icon). When the operator



FIGURE 3 - Pendant Items

presses the 9 button in the weld (idle) screen, the value for the Wire Feed (white icon) will be presented and can be changed by the left toggle (white border) and the value for Amps (gray icon) will be presented and can be changed by the right toggle (gray border).

Fast Movement

Certain screens allow for fast movement using the steering knob. Movement and selection can still be accomplished with the left and right toggle. In addition the steering knob will allow the user to change the selection by turning the knob and moving to the next section by pressing the knob.

For fast movement between selections hold the steering knob down while turning to rapidly move from one selection to the other.

System Log In

When powered on, the system will go through a self-calibration routine. Make sure the torch is free to move before starting the system.

When the calibration routine is complete, the user will be presented with a Log In Screen – see **FIGURE 2 - Log In Screen on page B-1** and **FIGURE 5 - Change User**. The system requires a four-digit user code to log in.

Fast Movement

Fast movement using the steering knob is enabled on this screen – see **FIGURE 4 - Fast Movement**. Use the steering knob or left and right toggles for navigation and selection.

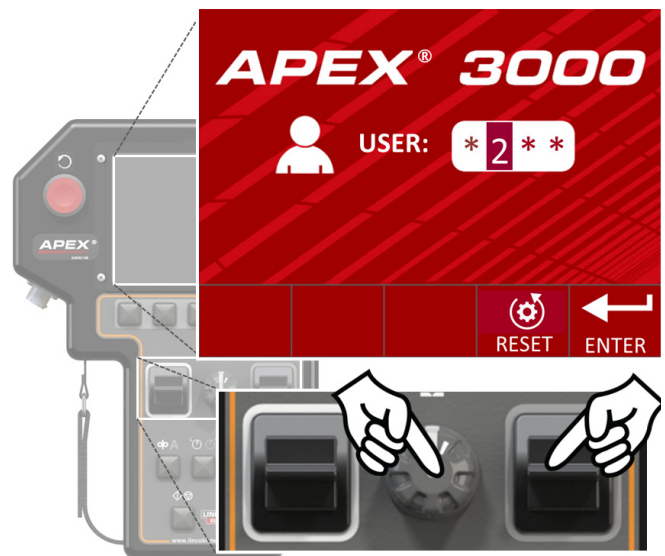

FIGURE 5 - Change User

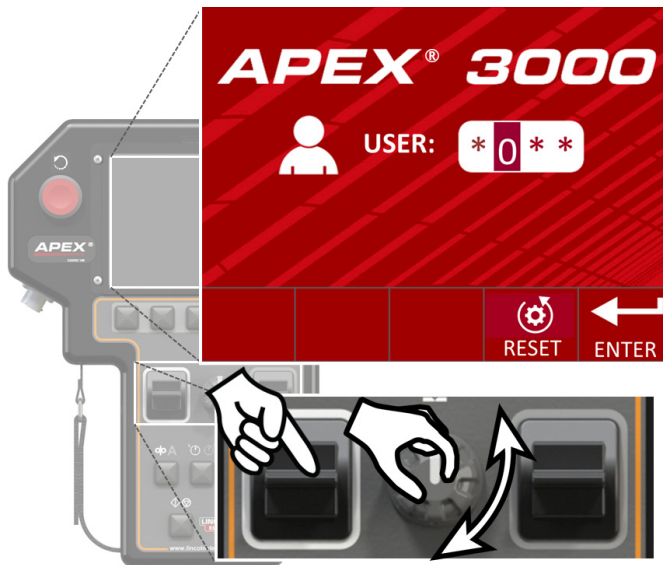

FIGURE 4 - Fast Movement

Use the left toggle or press the steering knob to change from one variable to the next. Use the right toggle or turn the steering knob to change the selected variable.

Press the Enter Selection button when the complete four digit user code has been entered. Once a four digit code is accepted, the system automatically moves into the default Idle screen – see **FIGURE 6 - Idle Screen Default**. This screen is shown when a supervisor logs into the system. Logging in as an operator will default to the Program Load Screen.

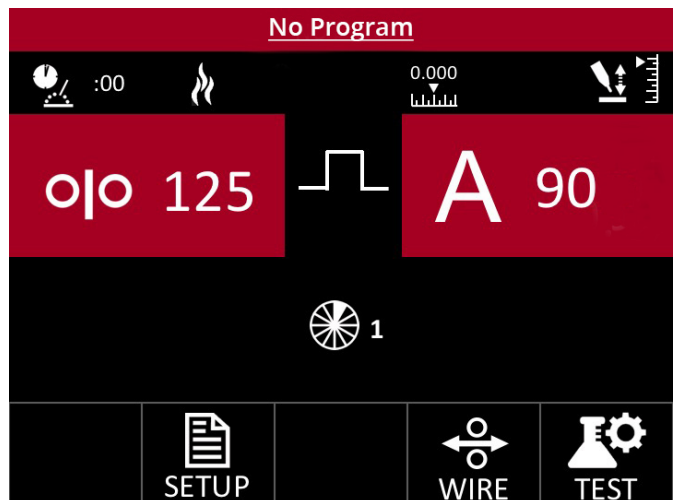

FIGURE 6 - Idle Screen Default

Log In Screen

The following buttons and options are available from the log in screen – see **FIGURE 7 - Log in Buttons**.



FIGURE 7 - Log in Buttons

1. N/A
 - No Effect
2. N/A
 - No Effect
3. N/A
 - No Effect
4. RESET
 - **Short Press** – Will change password entry back to “0000”
5. ENTER
 - **Short Press** – Attempts to log in to the system with the currently entered user code
6. LEFT TOGGLE (White Border)
 - **Short Press** – Pressing up or down moves cursor between spaces
7. STEERING KNOB
 - **Short Press** – Moves cursor to the next space
 - **Rotation** – Quickly cycles through available character options
 - **Hold & Rotate** – Quickly moves the cursor from one selection to the next
8. RIGHT TOGGLE (Gray Border)
 - **Short Press** – Pressing up or down changes value of the selection
9. WIRE FEED/AMPS
 - No Effect
10. DWELL
 - No Effect
11. OSCILLATION
 - No Effect
12. TRAVEL/VOLTS
 - No Effect
13. START/STOP
 - No Effect
14. SECTOR
 - No Effect
15. RESET
 - **Short Press** – Initiates a system reset

Idle Screen

The Idle Screen is the first screen presented to a supervisor when logging in – see **FIGURE 6 - Idle Screen Default on page B-4**. This screen allows the supervisor to set up all parameters for welding, test the parameters if necessary and to start welding.

Menu Option Variables

The Idle Screen will show the user eight variables (two variables on four separate screens), depending on which Menu button has been pressed. Pressing the different Menu buttons will change the values shown. The different variables shown correspond to the icons on the Menu buttons.

Similar variables are paired together. The variables shown on the screen can be changed using the left and right toggles. It is possible to change between these menu options while idle or welding.

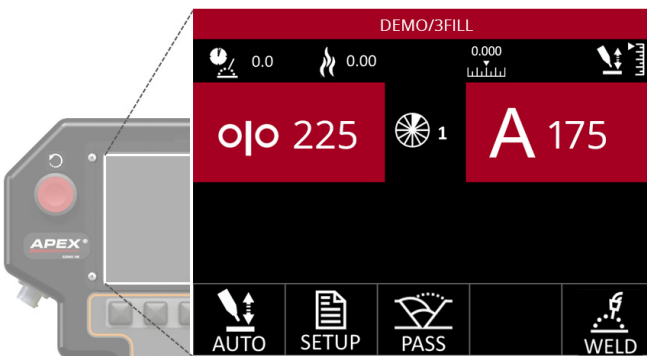

Press the Menu button to open the Wire Feed/Amps Menu options

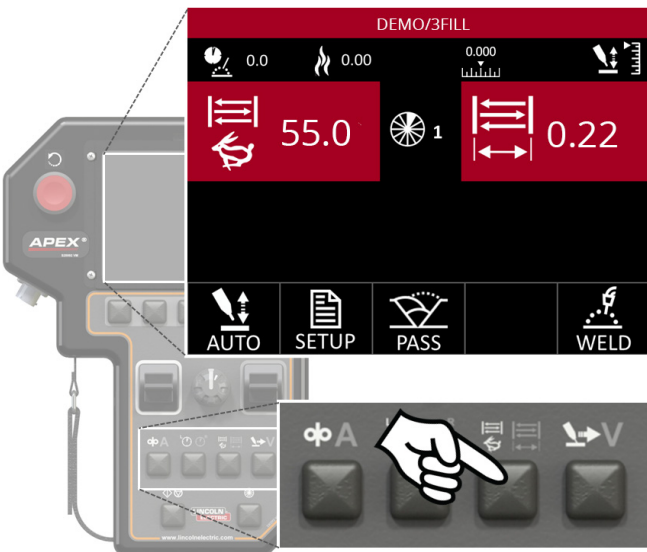

Press the Menu button to open the Oscillation Menu options



Press the Menu button to open the Dwell Menu options



Press the Menu button to open the Travel/Voltage Menu options

Idle Screen Buttons

The Idle Screen – see **FIGURE 8** – will change depending on which menu button has been selected. Some items in the Selection button windows will change depending on system configurations.

1. AUTO HEIGHT

- **Short Press** – Turns Auto Height on and off in weld mode

2. SETUP

- **Short Press** – Navigates to the Setup Screen

3. PASS

- **Short Press** – Switches to the next pass in the weld program (if available)

4. N/A

- **No Effect**

5. TEST/WELD

- **Short Press** – Switches between weld and test modes (Image shows system in Weld Mode)

6. LEFT TOGGLE (White Border)

- Changes the value displayed in the top left box (in this example it will change the value in the left dwell box)

7. STEERING KNOB

- **Rotate** – Moves the oscillation in and out
- **Short Press** – Centers the oscillation
- **Long Press** – Starts/stops oscillation test

8. RIGHT TOGGLE (Gray Border)

- Changes the value displayed in the top right box (in this example it will change the value in the right dwell box)

9. WIRE FEED/AMPS

- **Short Press** – Wire Feed/Amps options
- **Long Press** – Navigates to the Jog Screen

10. DWELL

- **Short Press** – Dwell options
- **Long Press** – Navigates to the Jog Screen Dwell

11. OSCILLATION

- **Short Press** – Oscillation options
- **Long Press** – Navigates to the Jog Screen Oscillation

12. TRAVEL/VOLTS

- **Short Press** – Travel/Voltage options
- **Long Press** – Navigates to the Jog Screen



FIGURE 8 - Idle Screen

13. START/STOP

- **Short Press** – Starts or stops welding or testing

14. SECTOR

- **Short Press** – Switches to the next sector if multiple sectors are enabled

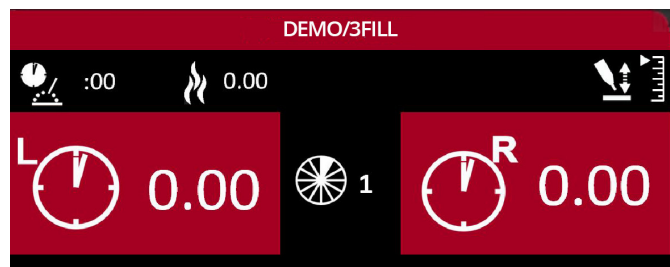

- **Current sector is displayed here at the center of the screen near the sector icon.**

15. RESET*

- **Short Press** – Initiates a system reset

***Important!** This is not an emergency stop button. Power is still being applied to the system. The system will ask you to wait as it resets.

Idle Screen Test/Weld Modes

After preparing a program, it is recommended that the user test the parameters before striking an arc. The system allows for a test mode of all non-weld functions such as travel, gas purge/flow, oscillation and others.

Press the Weld/Test Selection button.

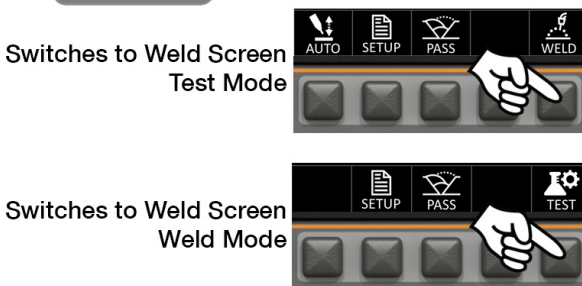
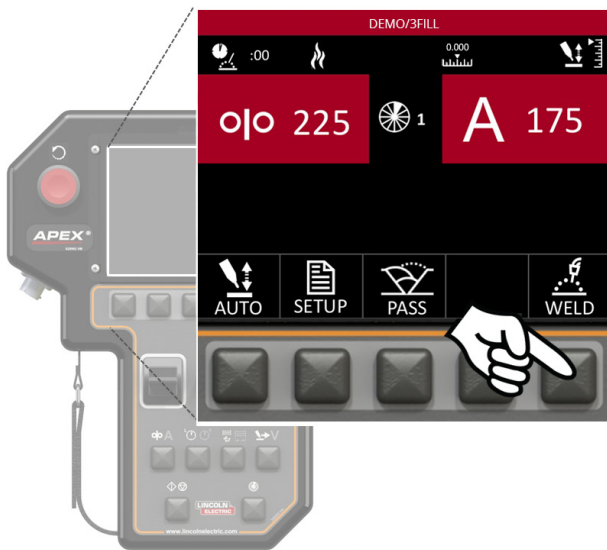

This example shows how to change the system from the Test Mode to the Weld mode. The icon in the Selection Button window indicates what mode the system is in.

Note: Auto Height is not an option while in Test Mode.

Pressing the Start/Stop Control Button will switch the pendant from the Idle Screen to the Test Screen or Weld Screen depending on which mode the user is in.

Static Screen Items

There are many icons common through the Idle, Weld and Test screens. These items give helpful information to the user throughout the setup and welding process.

1. **Arc Time** – Indicates the amount of time spent welding
 2. **Heat Input** – Displays the amount of heat input for the current weld in kilojoules/in or kilojoules/cm.
 3. **Sector** – Displays the current sector in the weld program, if applicable
 4. **Program Name** – Displays the currently loaded weld program and program pass.
- Note: Program Name changes to Italics when program parameters have changed.*
5. **Oscillation Location** – Displays the relative location of the oscillation axis.
 6. **Torch Height** – Displays the relative location of the height axis.

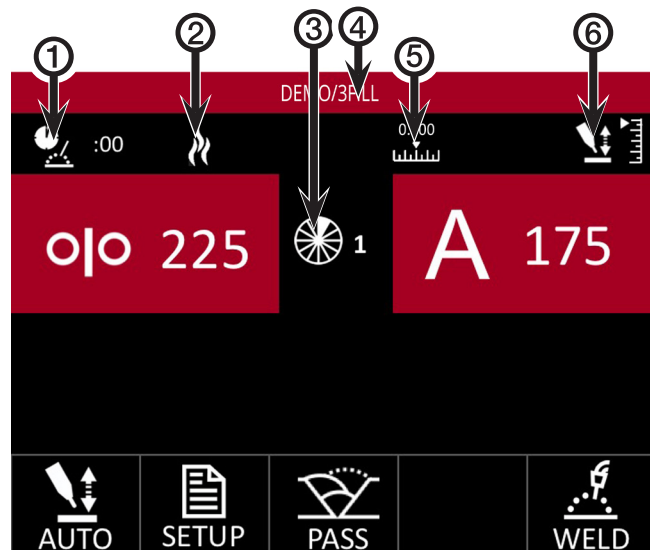

FIGURE 9 - Static Items

The screen shot above – **FIGURE 9 - Static Items** – illustrates the icons that appear on the weld screen. These icons are for information only and are not selectable variables.

Weld Screen

During the weld, the screen will show voltage and amperage feedback on the Weld Screen – see **FIGURE 10 - Weld Screen Options**. Pressing the menu buttons will move the user through the Menu Option Variables similar to **FIGURE 12 - All Test Screens**.

The Setup Selection is replaced with the Adv Selection. Autoheight can also be engaged or disengaged. See **FIGURE 10 - Weld Screen Options**.

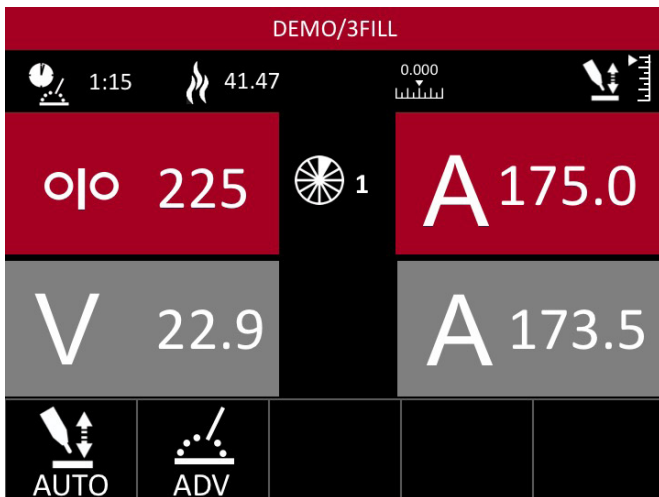

FIGURE 10 - Weld Screen Options

Weld Screen Buttons

The Weld Screen buttons work similar to the Idle screen buttons – see **Idle Screen section on page B-7**.

Pressing the Start/Stop button during the weld halts the weld and moves into the Jog Menu. See **FIGURE 15 on page B-11**.

Test Screen

Similar to the Weld Screen, the Test Screen will show voltage and amperage feedback but the feedback values will be zero – **FIGURE 11 - Test Screen Options**. Pressing the menu buttons will move the user through the Menu Option Variables as shown in the Idle Screen section.

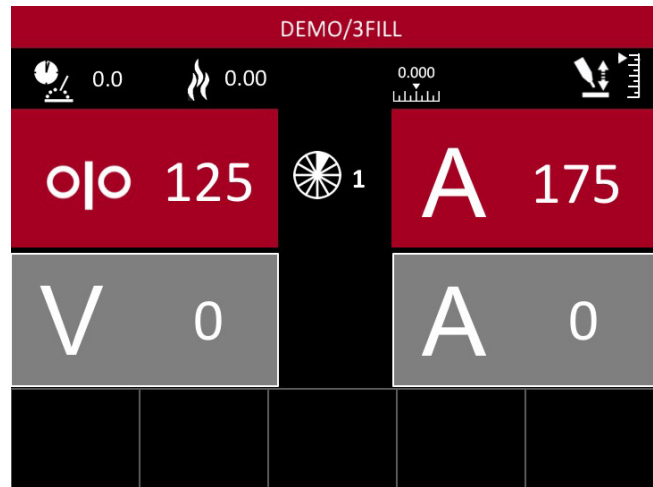

FIGURE 11 - Test Screen Options

Test Screen Buttons

The Test Screen buttons work similar to the Weld screen buttons – see **FIGURE 12 - All Test Screens**.

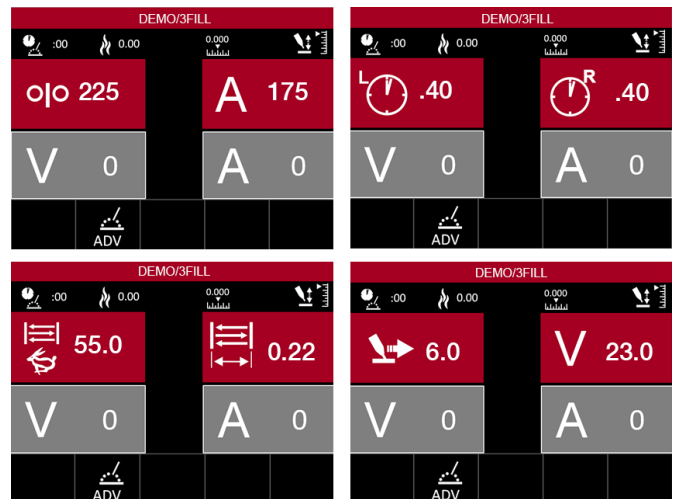

FIGURE 12 - All Test Screens

Jog Screen

The Jog Screen – **FIGURE 15 - Jog Menu Screen** – is used to test movement of the system before welding. The Jog Screen can be entered from the Idle or Oscillation screens.

From the Idle Screen, press and hold the Wire Feed/Amps or the Travel/Voltage menu buttons to enter the Jog Menu.

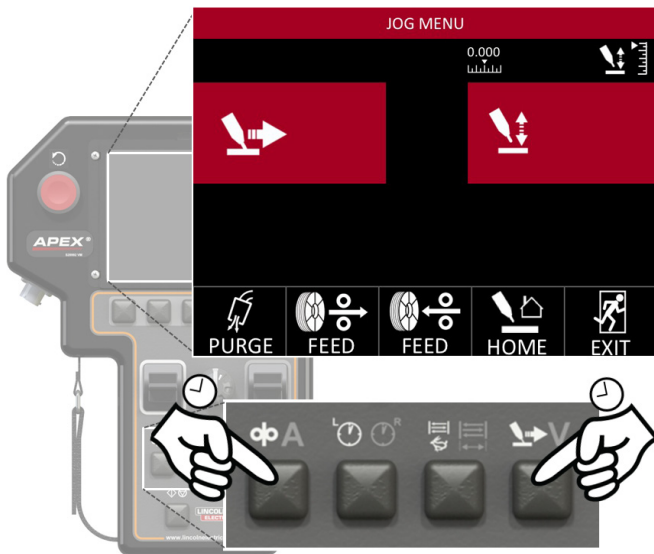

FIGURE 13 - Engaging Jog Mode

The screen above – **FIGURE 13 - Engaging Jog Mode** – provides for moving the weld head along the track, adjusting torch height, purging gas and shows the icons for both the cold feed forward and cold feed reverse.

Press the Exit selection button to return Idle screen as shown in **FIGURE 14**, below.

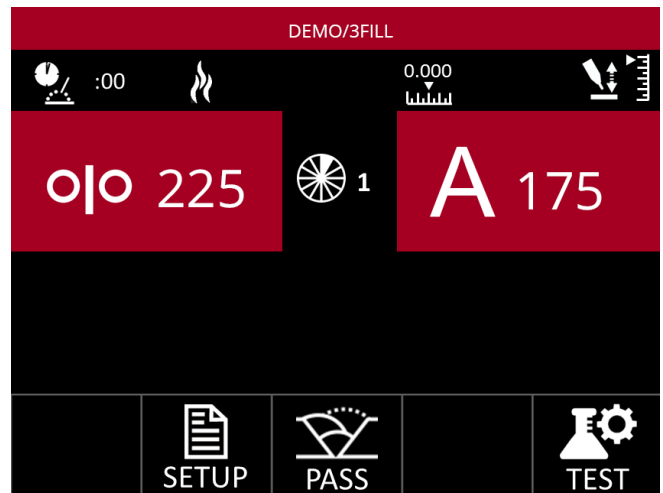

FIGURE 14 - Idle Screen Options

Jog Buttons

The following buttons and options are available from the Jog Menu.

1. GAS PURGE

- **Short Press** – Purge welding gas for 3 seconds
- **Hold** – Continually purges welding gas while held

2. COLD FEED FORWARD

- **Short Press** – Feeds wire slightly
- **Hold** – Feeds wire continuously and accelerates the WFS

3. COLD FEED REVERSE

- **Short Press** – Retracts wire slightly
- **Hold** – Retracts wire continuously and accelerates the WFS. Be sure to keep the spool tight as wire is retracted

4. HOME

- **Short Press** – Returns the weld head to starting position on the track. Starting position is determined by previous weld or test start.

5. EXIT

- **Short Press** – Returns to Idle Screen

6. LEFT TOGGLE (White Border)

- **Short Press** – Travels forward or backward slightly
- **Hold** – Travels forward or reverse and ramps travel speed

7. STEERING KNOB

- **Rotate** – Moves the oscillation in and out
- **Short Press** – Centers the oscillation
- **Long Press** – Starts/stops oscillation test

8. RIGHT TOGGLE (Gray Border)

- **Short Press** – Adjusts the torch up and down
- **Hold** – Adjusts the torch up and down and ramps adjustment speed

9. WIRE FEED/AMPS

- **No Effect**

10. DWELL

- **Short Press** – Navigates to Jog Menu for oscillation and dwell (short press does the same)
-

11. OSCILLATION

- **Short Press** – Navigates to Oscillation screen

12. TRAVEL/VOLTS

- **No Effect**



FIGURE 15 - Jog Menu Screen

13. START/STOP

- If in **TEST**, it will run the **TEST MODE**; if in **WELD**, the machine will start the weld

14. SECTOR

- **No Effect**

15. RESET*

- **Short Press** – Initiates a system reset

***Important!** This is not an emergency stop button. Power is still applied to the system.

Oscillation Screen

The Oscillation Screen is used to test and adjust system oscillation before welding. To enter, press and hold the Dwell or Oscillation menu buttons while in the Jog, Idle or Weld screens.

From the Idle screen, pressing and holding the Oscillator Menu Button will present the user with the option to change the oscillation width and the oscillation speed.

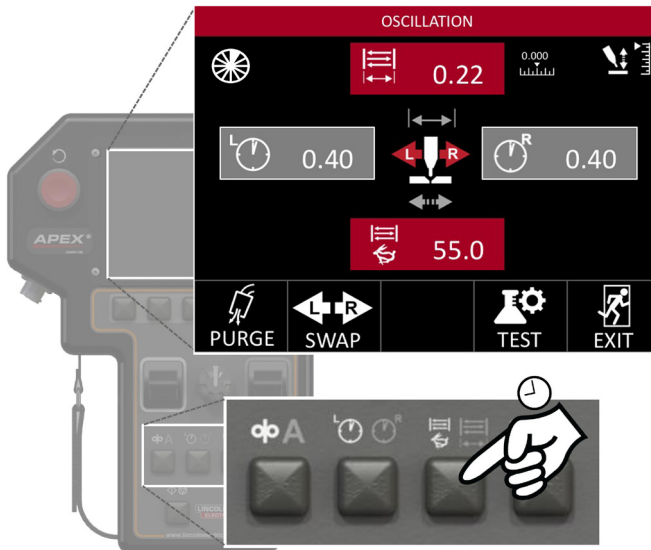

Press the Swap Selection Button to be taken to the Travel Setup Screen.



Travel Setup is discussed in the Travel Setup Screen section on **page B-16**. This screen allows the user to quickly change weld head orientation or change the weave pattern.

From the Idle screen, holding down the Dwell Menu Button will present the user with the option to change the left and right dwells.

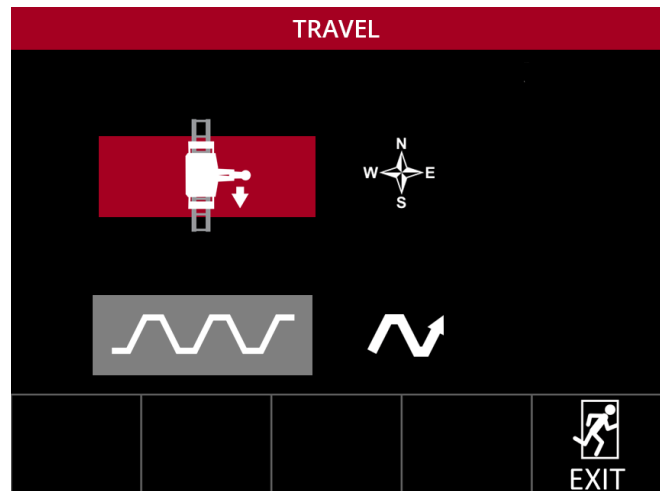
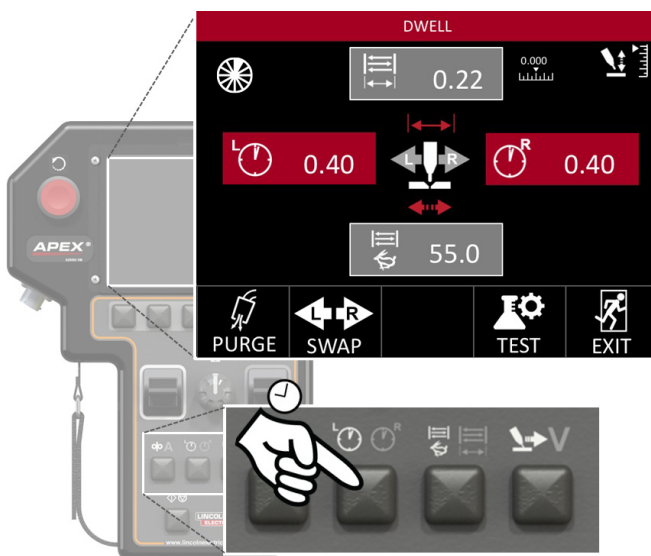

Press the “Exit” selection button to return to the Jog Screens. Once all parameters have been input and checked, exit out of the Jog Screen to return to the Weld (also called the “Idle”) Screen.

In either screen, use a short press to switch between Oscillation and Dwell. The items highlighted in red are the variables that can be changed.

Oscillation Buttons

The following buttons and options are available from the from the Oscillation menu:

1. PURGE

- **Short Press** – Purge welding gas for 3 seconds
- **Hold** – Continually purges welding gas while held

2. L/R SWAP

- **Short Press** – Navigates to the Travel Direction Setup Screen

3. N/A

- **No Effect**

4. TEST/WELD

- **Short Press** – Starts/Stops oscillation test

5. Exit

- **Short Press** – Returns to Idle Screen

6. LEFT TOGGLE (White Border)

- **Short Press** – Increases or decreases Left Dwell time or Oscillation Width
- **Hold** – Increases increment speed

7. STEERING KNOB

- **Rotate** – Moves the oscillation in and out
- **Short Press** – Centers the oscillation
- **Long Press** – Starts/stops oscillation test

8. RIGHT TOGGLE (Gray Border)

- **Short Press** – Increases or decreases Right Dwell time or Oscillation Speed
- **Hold** - Increases or decreases value continuously

9. WIRE FEED/AMPS

- **Short Press** – Navigates to Jog Menu

10. DWELL

- **Short Press** – Switches to Dwell option (when in Oscillation option, otherwise no effect)

11. OSCILLATION

- **Short Press** – Switches to Oscillation option (when in Dwell option, otherwise no effect)

12. TRAVEL/VOLTS

- **Short Press** – Navigates to Jog Menu



FIGURE 16 - Oscillation Screen

13. START/STOP

- **Starts and stops TEST or WELD MODE**

14. SECTOR

- **Short Press** – If multiple sectors are available, a short press will move to the next available sector and display the values associated with that sector.

15. RESET*

- **Short Press** – Initiates a system reset

***Important!** This is not an emergency stop button. Power is still being applied to the system.

Setup Menu

The setup screen allows the user to access all parameters for welding. Please note that this screen can only be accessed by authorized supervisors set up in the User's Menu. This is explained further in the User's Setup Screen section.

The Setup Menu – see **FIGURE 17 - Setup Menu** – can be accessed from the Weld Menu. This menu is accessible in either test or weld mode, but it is not accessible while welding. Press the Setup Selection button to enter into the setup screen.



Once in the SetUp Menu, the user has access to multiple system screens.

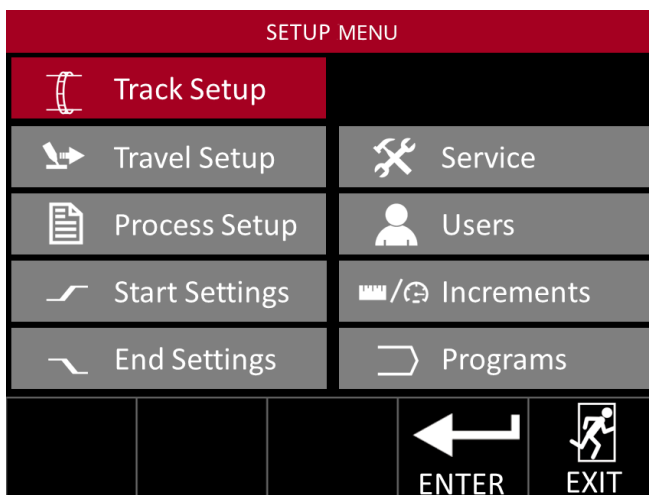
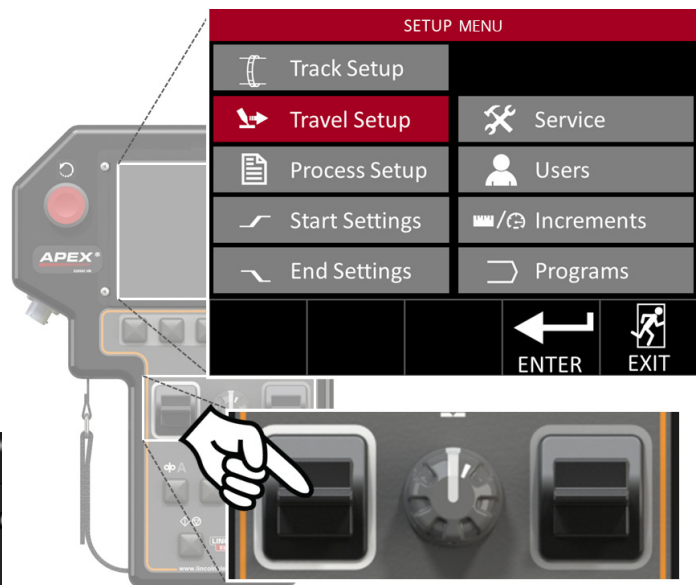

FIGURE 17 - Setup Menu

To select the individual screens, the user moves the red cursor to the desired field using the Left Toggle (White Border), and presses the Enter Selection button.



Pressing Exit will return the user back to the Idle screen.

Setup Screen Options

Track Setup – employs internal or external track, flat track and the size of the pipe (where applicable).

Travel Setup – change the steering controls based on where the operator is standing in relation to the track, and set up the weave pattern.

Process Setup – sets up the weld process.

Start Settings – adjustment specific to the programs affecting how the system will react when the weld starts.

End Settings – adjustment specific to programs, affecting how the system will react when the weld ends.

Service – access to current software information and can change certain motion settings, as well as monitor production, faults and tests.

Users – assigns operator and supervisor codes for the system.

Increments – allows limits and the increment value of each welding variable to be set. This screen also enables the user to choose between imperial and metric units.

Programs – The Programs screen is where all programs are saved, loaded, deleted or copied.

Track Setup

The Track Setup Screen presents the user with several options. From this screen the operator can change the type of track, the size of the track and the size of the pipe.

Track Type

The first selectable option is track type. With the track type field highlighted in red the user is able to switch between the different types of tracks. These tracks consist of:

- Outside Diameter (OD) Track
- Inside Diameter (ID) Track
- Flat Track

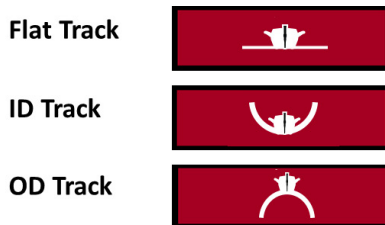
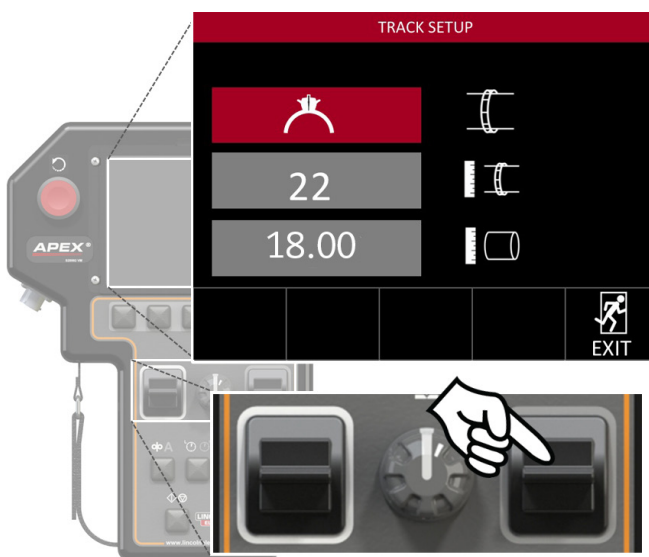

Track Ring Size

Track sizes range from 4 to 100 inches in increments of 2 inches. Pressing and holding the right toggle will increase the speed at which the values change. Use the nominal sizes for the track rings. **THESE NOMINAL SIZES ARE STAMPED INTO THE TRACK.**

Pipe Size

The third field that can be changed is the pipe size. Currently this can range from 4 inches to 100 inches.

The value can be adjusted in increments of 0.01 inches. Holding the right toggle for longer than 2 seconds will amplify the speed at which the values increase.

Entering the correct value for track and pipe size ensures accurate travel speed.

Heavy Wall Pipes

Heavy wall pipes may require the user to change the pipe size in later passes.

Example: A 20 inch Schedule 120 pipe has an OD of 20 inches and an ID of 17 inches. The pipe diameter for the root pass should be entered as 17.00 inches, then increased as the weld progresses outward. This will help to maintain an accurate welding travel speed throughout the weld.

Note: For additional OD and ID pipe and tube size information, please refer to the “Standard Schedule Pipe and Tube Chart” on **page 36**.

Positioner Setup

This system can be used as a part of a 1G system with certain positioners. When the system detects positioners as part of the setup, the Travel Setup screen will change. See **FIGURE 18 - Track Setup Screen**.

When the system is set to control multiple positioners the right toggle will switch between positioner A and B.

Use the Index Selection buttons to index the weld head on its mount.

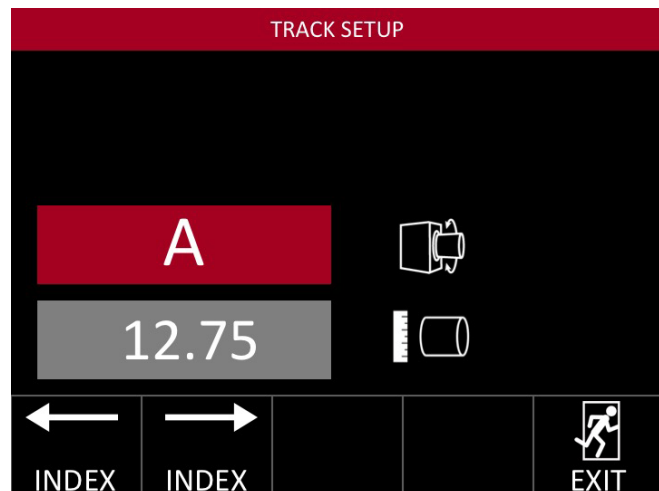

FIGURE 18 - Track Setup Screen

When the system is used to control positioners, the weld screens will show the current positioner as a selection. Pressing the Positioner Selection button will switch from positioner A to positioner B.

Travel Setup Screen

The travel setup allows the supervisor to set how the travel controls will work while welding and change the weave pattern.

Travel

The operator has the option of choosing how the weld head is oriented on the track. Setting the orientation and travel direction allows for intuitive operation.

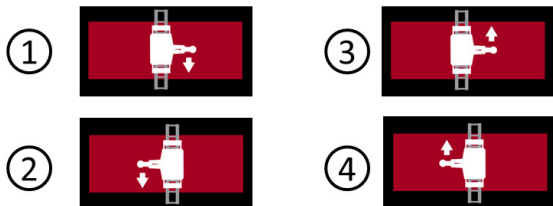
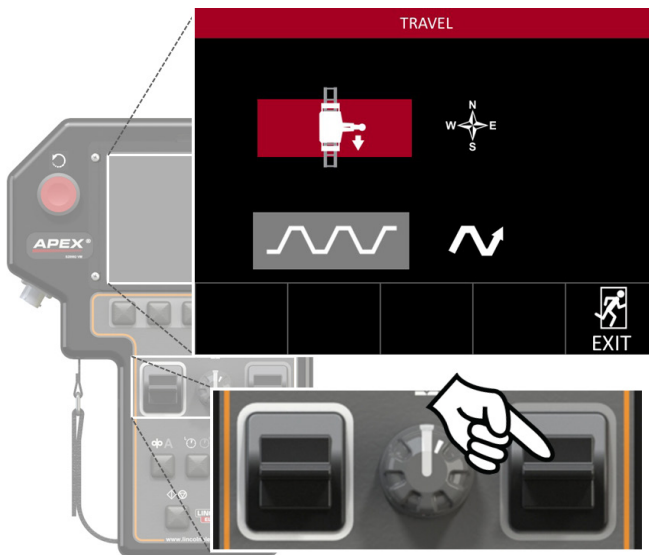

With the travel field highlighted, the weld head orientation and the travel direction can be selected. There are four different options available. All directions refer to the weld head and are in relation to the user's view facing the weld head.

1. Facing Right, Traveling Down
2. Facing Left, Traveling Down
3. Facing Right, Traveling Up
4. Facing Left, Traveling Up

Travel Pattern

The second field the operator can choose is the weave pattern. There are three options to choose from:

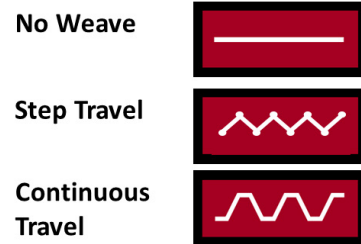
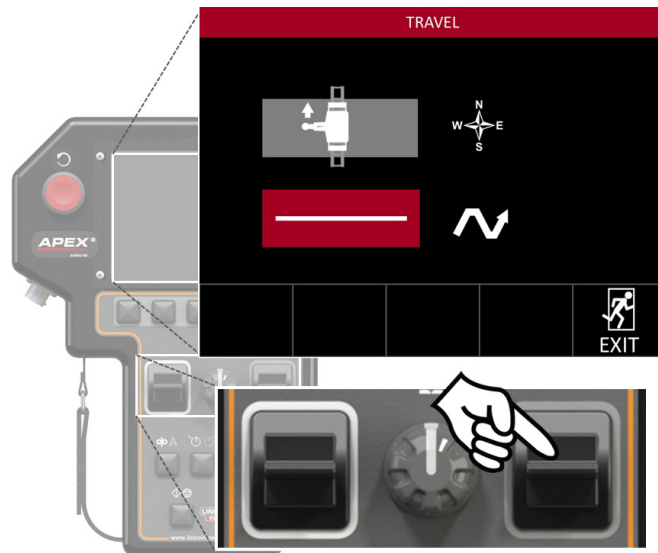

No Weave

When no weave is selected, the oscillator does not move during the welding process. The user can still manually steer the oscillator.

Step Travel

During step travel, the travel speed stops during the dwells. This allows the energy to be directed to the side walls.

Continuous Travel

Continuous travel will continue travelling throughout the weld process, during oscillation, excursion and dwells.

Process Setup Screen

The Process Setup Screen – see **FIGURE 19** - **Process Setup** – allows the user to select from several options to determine the variables in the weld.

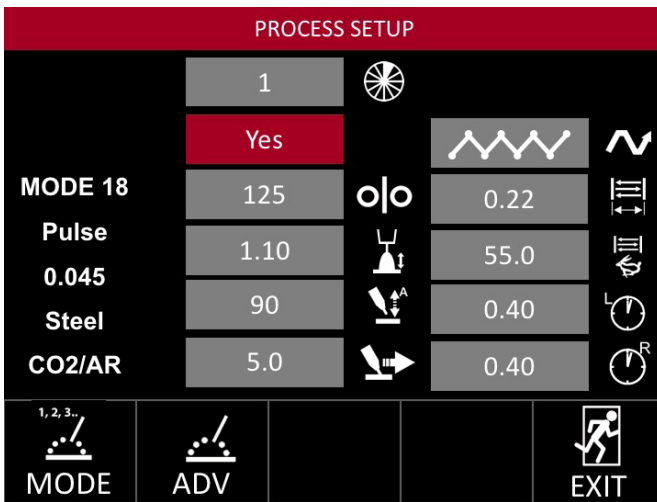

FIGURE 19 - Process Setup

Standard Process Options

Certain process options should be set up for every weld and every sector. These options are:

- **Sector** – Determines which sector the options are being set for out of eight possible sectors.
- **Wire Speed** – Sets wire feed speed
- **Trim/Voltage** – Controls the welding arc length.
- **Torch Height (Amperage)** – Controls the welding amperage by raising or lowering the torch when the Auto Height is turned on.
- **Travel Speed** – Sets the electrode travel speed

Enabling a sector presents the process variables for that sector. With only one sector selected, the Idle, Weld and Test screens will not show the sector icon.

Weave Process Options

- **Weave** – Refer to the Travel Pattern section on page **B-16** for the different weave options.
- **Oscillation Width** – Determines the width of the oscillation weave (limited by the weld head)
- **Oscillation Speed** – The speed at which the torch moves during oscillation
- **Left Dwell** – How long the torch remains on the left side of oscillation
- **Right Dwell** – How long the torch remains on the right side of oscillation

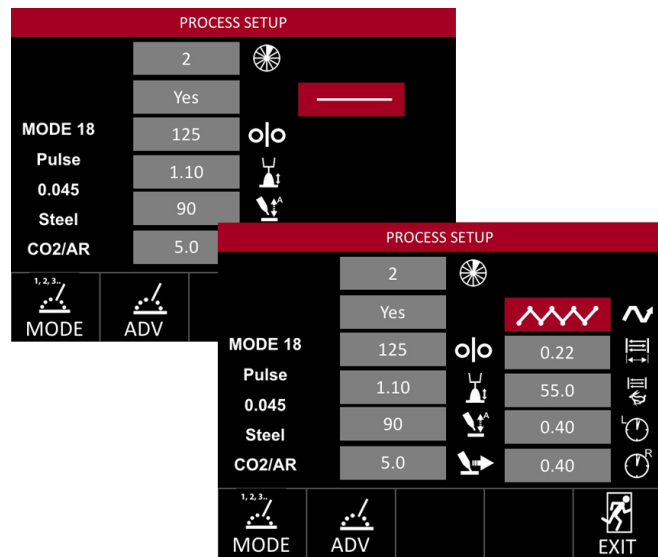

The purpose of this screen is to set up base settings before the weld begins. Without a weave selected, oscillation settings will not appear on the screen.

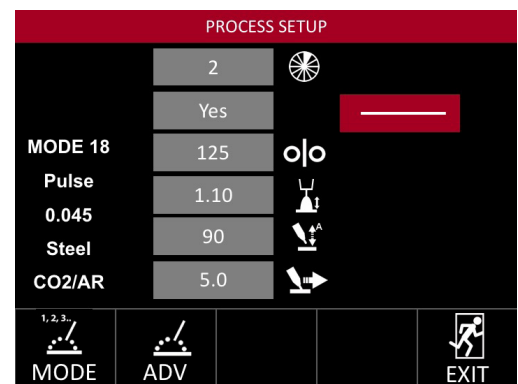
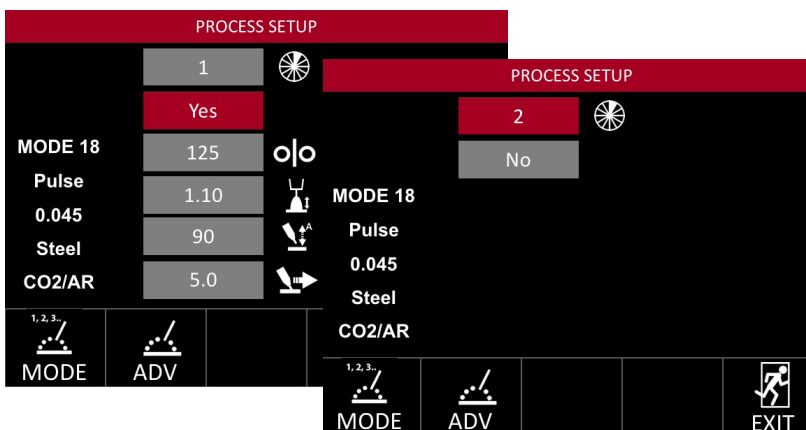

Mode Select

The weld mode is determined by the wire size, type, process and type of gas being used. Refer to the Power Wave® operator's manual for additional information about weld modes. The system can be a guide when the user is not sure which mode is appropriate for their application.

Pressing the Mode selection button will take the user to the Manual Mode Select Screen.

The user is prompted to select the wire size, type, process and then gas type. Mode Select guides the user through the settings. Selecting a wire diameter moves to wire type. See **FIGURE 20 - Manual Mode Select**.

Selecting wire type leads to a specific process and then to gas selection.

Each selection filters the list of available weld modes to match your application. A cored wire would not allow the user to select an STT® process.

The selected mode is displayed on the left side of the screen – see **FIGURE 21 - Process Setup**. These processes are accessed from the Power Wave, and are updated with the standard Power Wave updates.

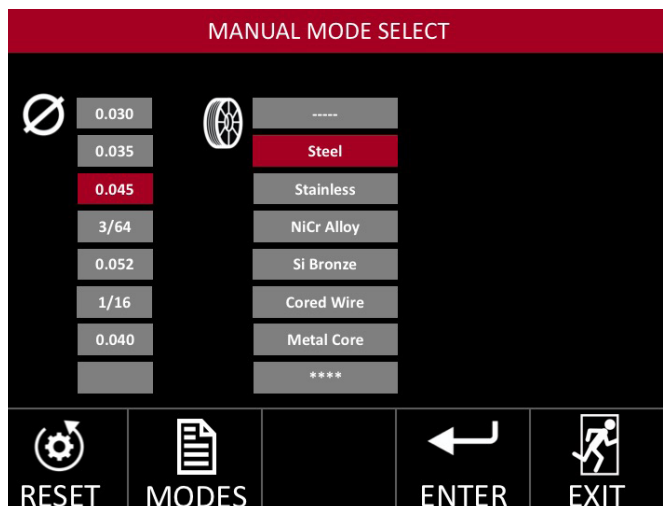
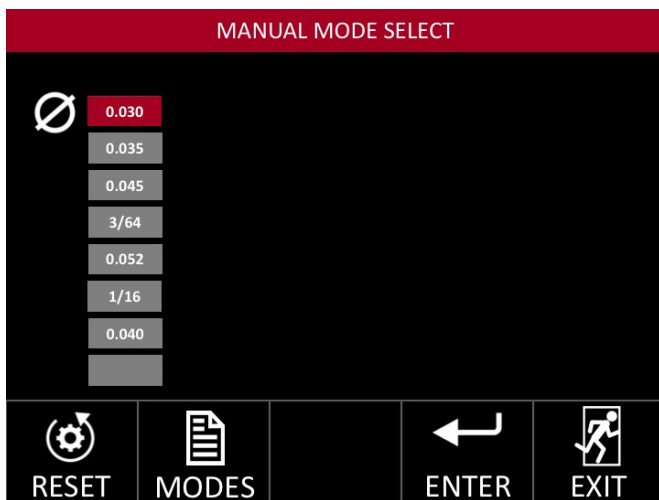

FIGURE 20 - Manual Mode Select

List Mode Select

Lincoln Electric power supplies come with pre-set welding modes for particular welding applications and wire types. Press the Modes selection button on the Manual Mode Selection Screen to see a list of weld modes loaded into the power supply.

Press the Modes selection button – see **FIGURE 21 - List Mode Screen** – below.

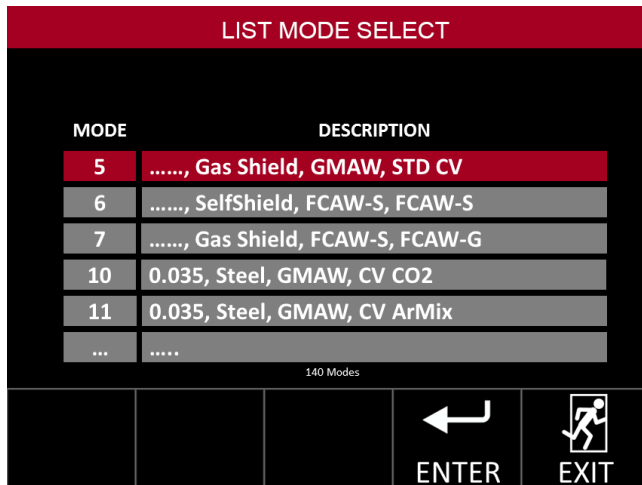

FIGURE 21 - List Mode Screen

The available weld modes are displayed in sequential order. The available modes depend on the present equipment.

Use the left toggle or turn the steering knob to choose an available weld mode then press the Enter Selection button.

Advanced Process Setup

Certain weld modes have advanced settings specific to that mode or process. Pressing the ADV Selection button on the Process Setup screen will present the user with the advanced options associated with the selected weld mode – see **FIGURE 22 - Advanced Settings**.

Advanced Options

Available options are based on the selected weld mode. See the Power Wave settings for a full breakdown and explanation of advanced options.

Wave Controls

Some typical wave controls are:

- Pinch
- Hot Start
- UltimArc®

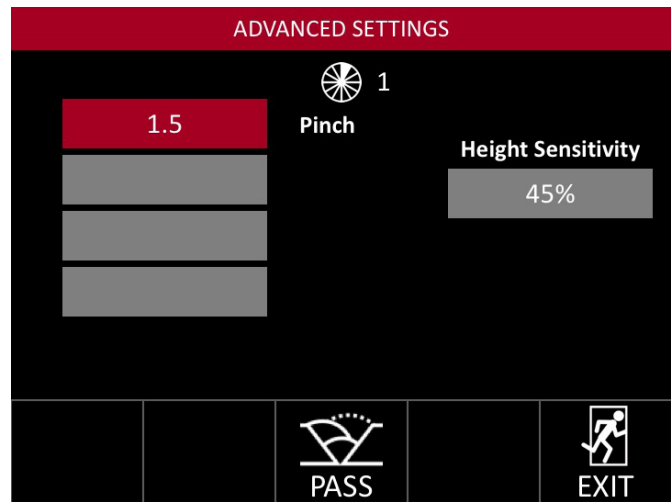

FIGURE 22 - Advanced Settings

Height Sensitivity

Height sensitivity is a global setting available regardless of the weld mode selected. The operator can program the system to react to changes following the profile of the joint.

Higher sensitivity will result in faster adjustment which could cause hesitation in torch height and abrupt changes in the weld as shown in **FIGURES A and B**.

Maintaining a low height sensitivity allows for higher quality and more consistent welds. This includes adjusting for out-of-round pipes, maintaining heat input and helping with puddle control on the joint profile. It is recommended that the operator start the weld at a lower sensitivity setting for the best performance. This will also assist in avoiding an over reaction to changes in the structure of the materials being welded.

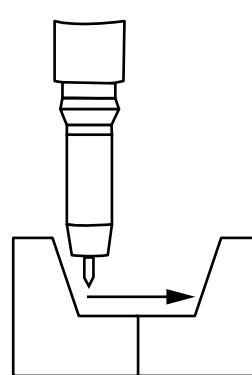

FIGURE A - JOINT
Low Sensitivity < 50

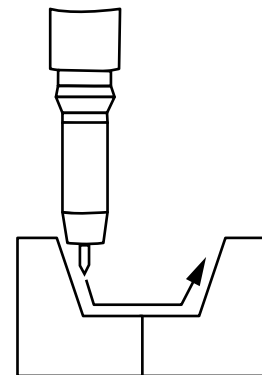

FIGURE B - JOINT
High Sensitivity > 50

Start Settings

The Start Settings should be set up after the process setup has been completed. The start settings screen – see **FIGURE 24 - Start Settings Screen** – allows the user to adjust the start settings specific to the program which affect how the system acts when the weld starts. The start settings take effect as soon as the Start/Stop button is pressed to initiate the weld. Refer to **page B-21** to see a full timing diagram.

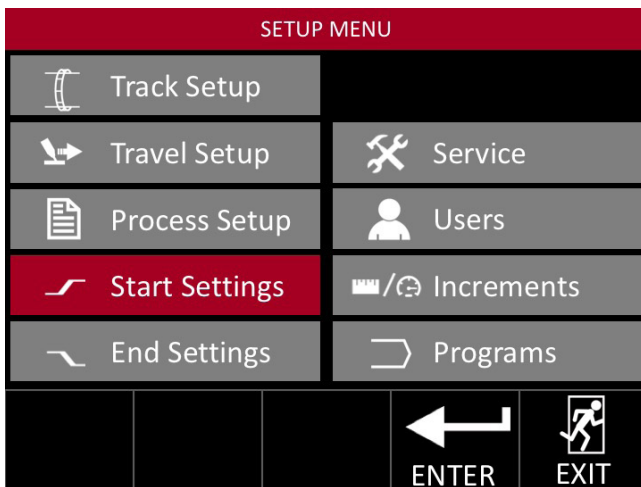

FIGURE 23- Setup Menu

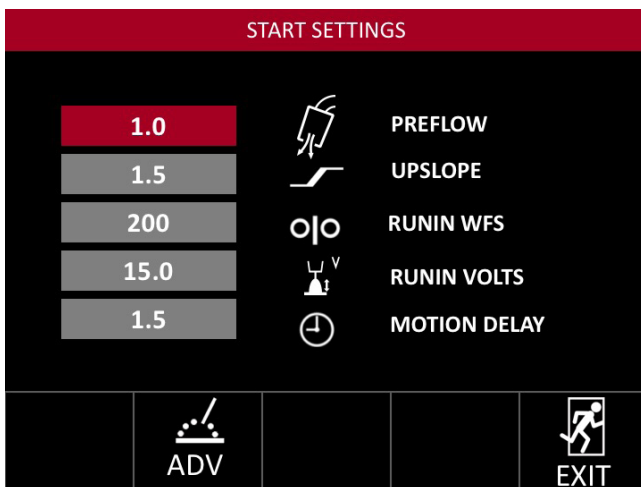

FIGURE 24 - Start Settings Screen

The settings that can be changed in this screen are:

Preflow

The amount of time (sec) that gas flows before welding begins to ensure adequate gas coverage for the weld preventing starting porosity.

Upslope

This is the amount of time (sec) it takes for the system to ramp up from start settings to welding parameters.

RunIn WFS

Determines the WFS prior to establishing an arc. Will ramp up to welding WFS during upslope.

RunIn Volts

The voltage or trim setting at which the system begins to weld. Once established, it will ramp to welding voltage during upslope.

Motion Delay

This determines how long the system will wait before beginning to travel and oscillate.

End Settings

The end settings screen – see **FIGURE 25 - End Settings Screen** – allows the user to adjust the end settings specific to the program, which affect how the system will behave at the end of the weld. End settings take effect as soon as the Start / Stop button is pressed to stop the weld. (Refer to **page B-21** to see a full GMAW/FCAW timing diagram.) The settings that can be changed in this screen are:

Crater WFS - The wire feed speed during crater

Crater Volts/Trim - The amount of voltage/trim during crater

Crater Time - The duration of crater

Burnback - The time the arc is maintained after the wire stops at the end of crater.

Downslope - The time to ramp from welding parameters to crater parameters

Postflow - How long the gas continues to flow after the weld to provide shielding

Both the Start and End Settings screens provide access to the Advanced screen to allow advanced values to be set for start and end of weld.

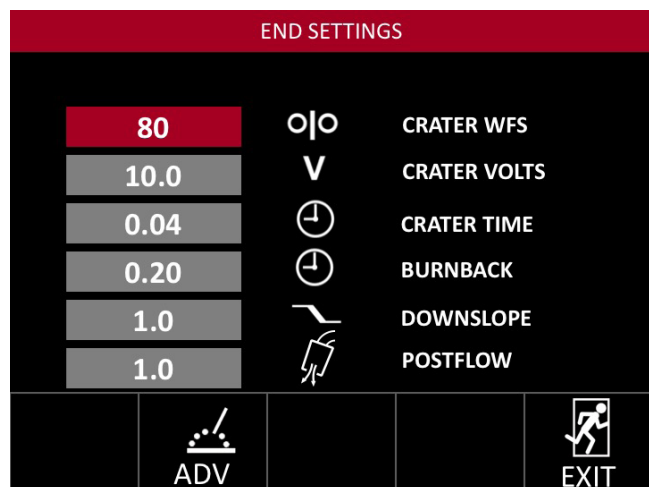
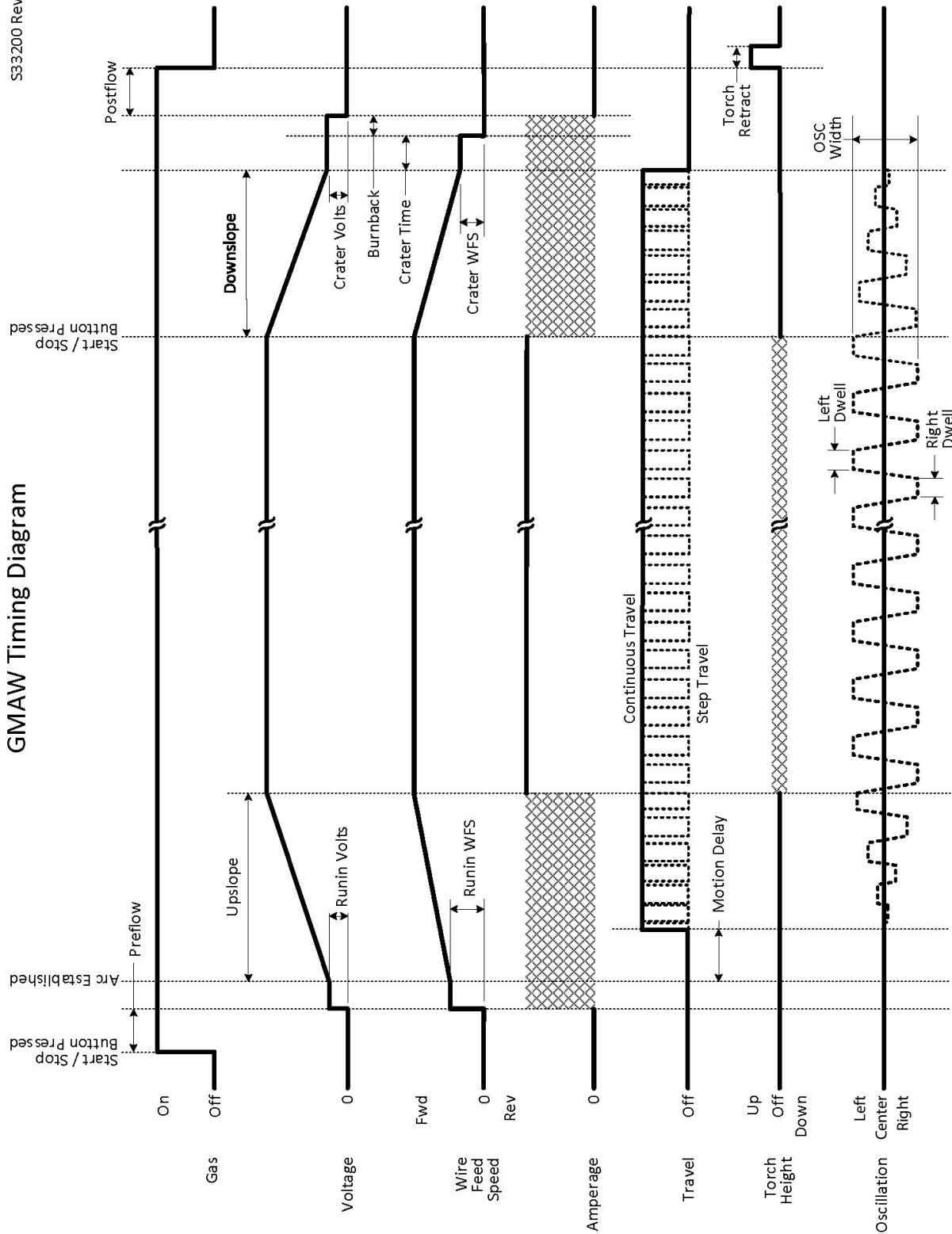

FIGURE 25 - End Settings Screen

S33200 Rev. A

GMAW Timing Diagram



Service Menu

The Service Screen allows for advanced welding options. There are five menus available in the Service Screen: Version, Motion, Faults, Settings and Input Tests.

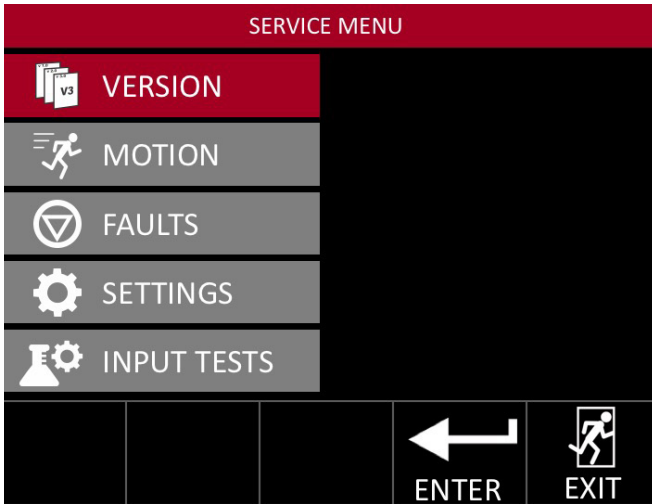

FIGURE 27 - Service Options Page

Version

The version option of the service menu shows the user information about the installed software and hardware. Paging through the screens can be done using the Next Selection button and the Previous Selection button – see FIGURE 27 - Service Screen Versions

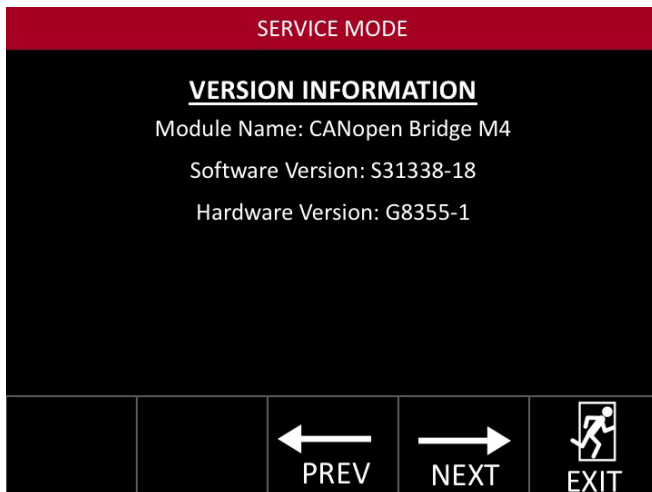

FIGURE 27 - Service Screen Versions

Motion

Motion controls allows the user to select certain motions and behaviors of the weld system – see FIGURE 28 - Motion Controls Screen – for available options.

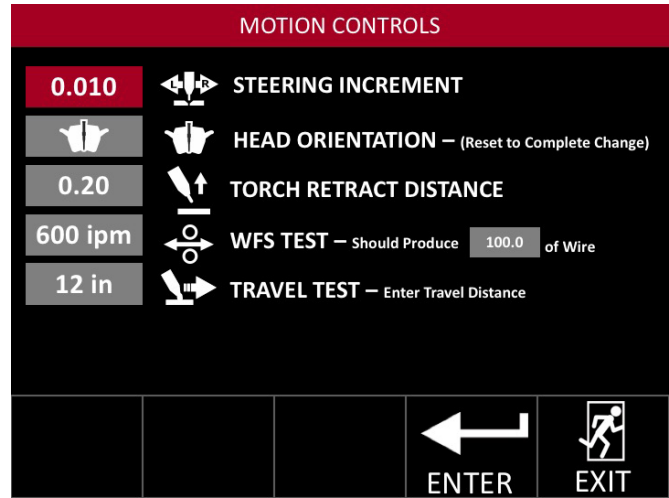

FIGURE 28 - Motion Controls Screen

Service Motion items are:

Steering Increment - Changes the distance the oscillation axis will move for each click of the steering knob.

Head Orientation - Rotating the orientation of the torch relative to the weld head requires changing the system settings and physically inverting the weld head. The setting must match the physical orientation.

Torch Retract Distance - Changes how far the torch retracts at the end of the weld. This allows for greater clearance, enabling a return home to trim the wire before restarting.

WFS Test - The APEX system performs all calibrations internally. However, in order to comply with welding standards, the system allows for verification. The WFS Test will produce a desired amount of wire for a preset length of time for verification.

Travel Test - The APEX system does all calibrations internally. However, in order to comply with welding standards, the system allows for verification. Travel Test will travel for the specified distance for verification. **The distance must be measured on the track ring gear or on a flat track.**

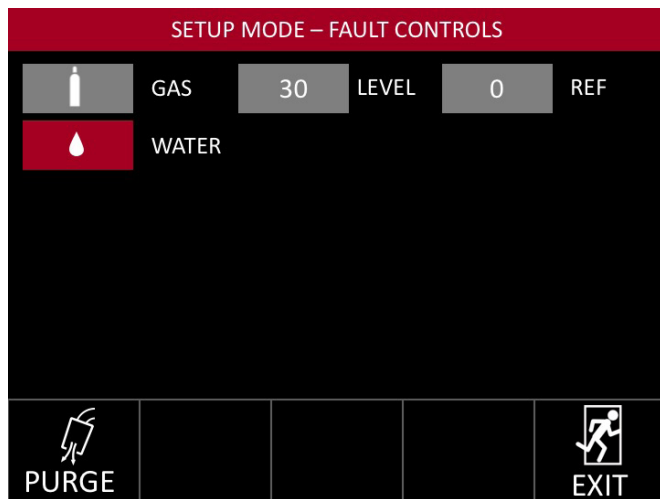

FIGURE 29 - Faults Screen On Settings

Faults

While welding, the flow of shielding gas and/or cooling water can be monitored if the appropriate hardware is present. For gas flow, the required level can be specified. The **Faults Screen On Settings** shown in **FIGURE 30** provides access to these features.

Water flow is detected by and ArcLink® connected CoolArc™ 55S.

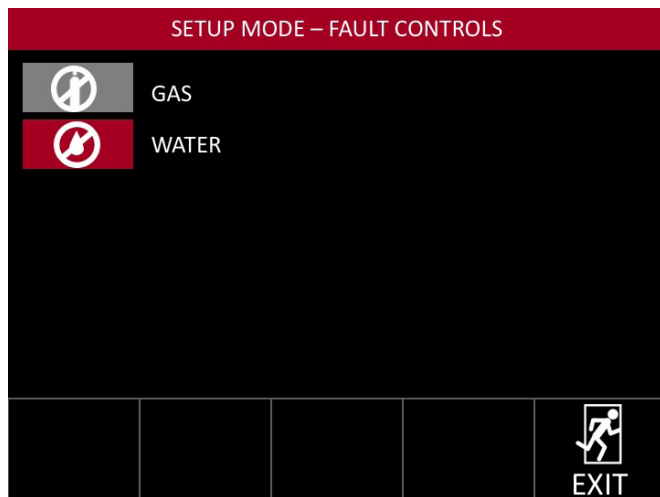

FIGURE 30 - Faults Screen Off Settings

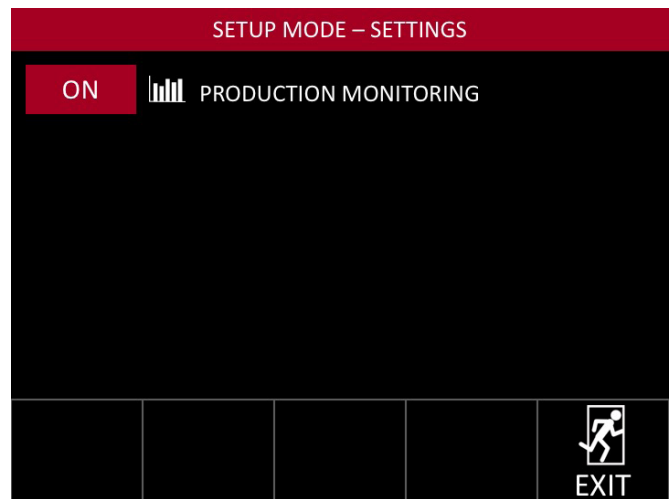

FIGURE 31 - Settings Screen

Use the Left Toggle to select GAS or WATER and then the Right Toggle to turn monitoring ON/OFF. With gas monitoring turned ON, two additional controls are made available; a LEVEL selection to input the required level of gas flow using the Right Toggle and a REF value which will display the current gas flow value when the PURGE button is pushed.

If the Gas Fault is turned ON, gas flow level will be monitored during welding and compared to the required flow level. If the monitored flow level is less than the required level, the weld will be terminated and a message will be displayed indicating a Gas Fault.

With the Water Fault turned ON, water flow will be monitored during welding. If it's determined that water is not flowing, the weld will be terminated and a message will be displayed indicating a Water Fault.

If the Gas and Water faults are turned OFF, welding will continue regardless of the level of Gas or Water flow. If the appropriate flow sensor hardware is not present in the system then the corresponding fault(s) should be disabled.

Settings

The Settings Menu shown in **FIGURE 31- Settings Screen** – provides access to the Production Monitoring feature. When enabled, it will automatically archive a summary of each weld to an inserted USB drive. Use the Right Toggle to turn this feature ON/OFF.

Input Test

The Input Test menu shown in **FIGURE 32 - Input Test Screen, page B-24** – provides a Supervisor with the ability to quickly determine if the pendant input devices (buttons, switches, and steering knob) are working correctly.

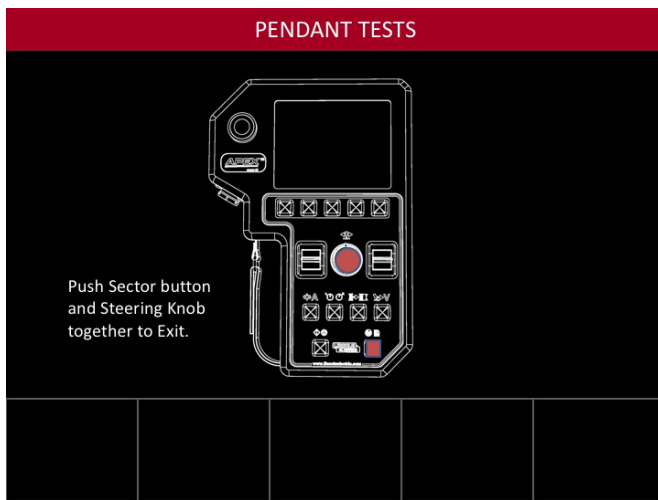

FIGURE 32 - Input Test Screen

Note: Pushing the Reset Button resets the system.

Once the Input Test screen is displayed, a system test may be performed. Each button and toggle switch on the Pendant will turn green when pushed up, down or released.

Turning the steering knob clockwise should turn the right portion of the knob green indicating the direction of the rotation. Turning the steering knob counter-clockwise should turn the left portion of the knob green indicating the direction of the rotation.

Pushing and releasing the steering knob button should turn the center of the knob green and produce a corresponding message. After operating all Pendant input devices, the representations of the devices on the screen should be highlighted in green. Any that are not highlighted are not working correctly.

Return to the Service Options page by pushing the steering knob and sector button at the same time.

How To Take A Snapshot

If a USB drive is inserted into the APEX 30M, APEX 30S or APEX 3000, the Pendant will allow a snapshot to be taken from the screen shown in **FIGURE 33 - Snapshot Service Mode**.

Snapshots can also be taken from the screen shown in **FIGURE 34 - Snapshot System Fault**.

A Snapshot provides detailed information concerning the systems current configuration and status and is initiated by pushing the SNAP Selection button.

The snapshot process may take several minutes to complete during which time a status screen like the one shown in **FIGURE 35 - Snapshot Status Screen** is presented.

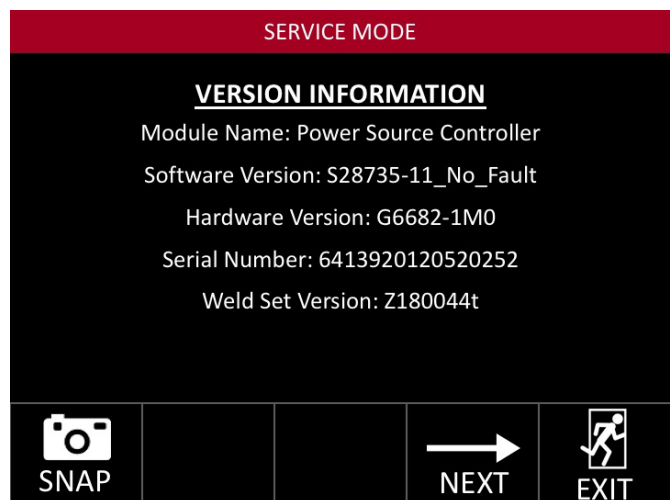

FIGURE 33 - Snapshot Service Mode



FIGURE 34 - Snapshot System Fault

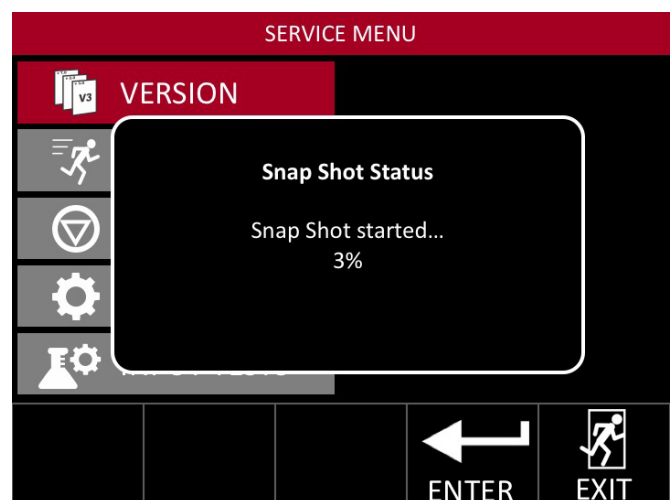

FIGURE 35 - Snapshot Status Screen

Users

The Users Screen – see **FIGURE 36 - Users Screen** – allows the user to set up operator and supervisor log in codes. Each user can be assigned an individual code which determines the level of access.

Fast Movement

Using the steering knob, Fast Movement is enabled on this screen. In addition, use the steering knob or the left and right toggles for navigation and selection.

Adding Users

Only those with supervisor access are able to view the users screen.

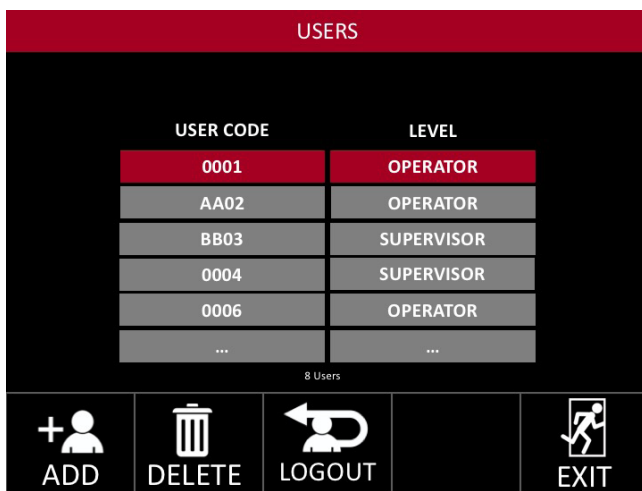

FIGURE 36 - Users Screen

Press the Add User Selection button.

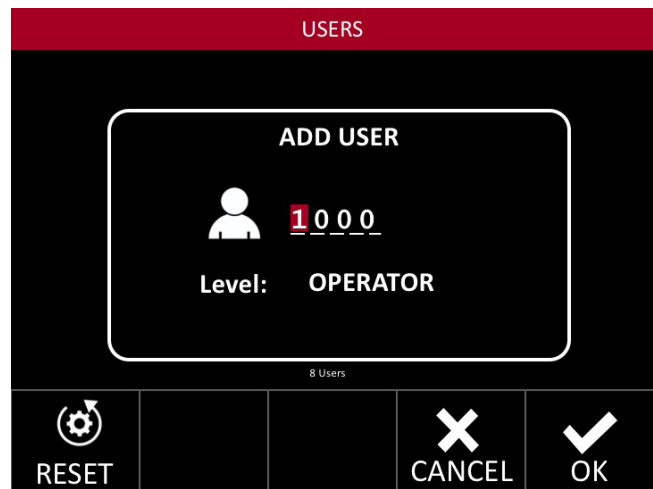

FIGURE 37 - Add User

As demonstrated in the example above, pressing the Add Selection button will bring up the Add User screen – see **FIGURE 37 - Add User**.

Once the code has been selected, the supervisor can determine the user’s level of access.

Operator - The operator has no access to the settings and will only be able to operate within the parameters placed by the supervisor for each program.

Supervisor - The supervisor has full rights and access to all weldings parameters and setup screens.

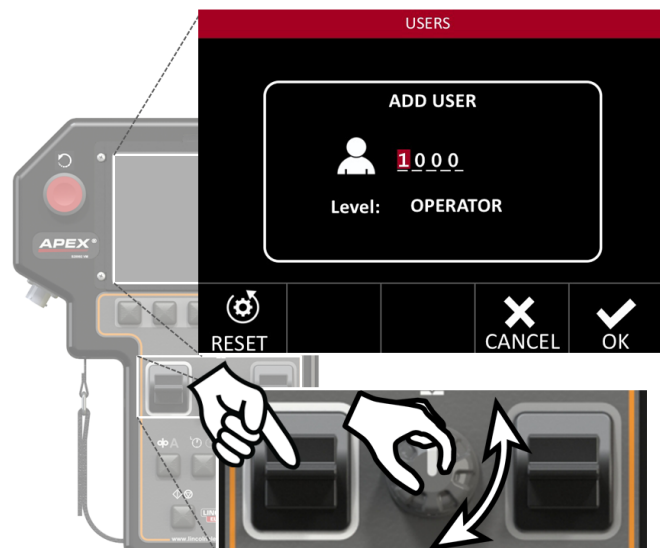

Changes the value of the selected item

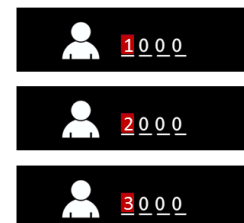

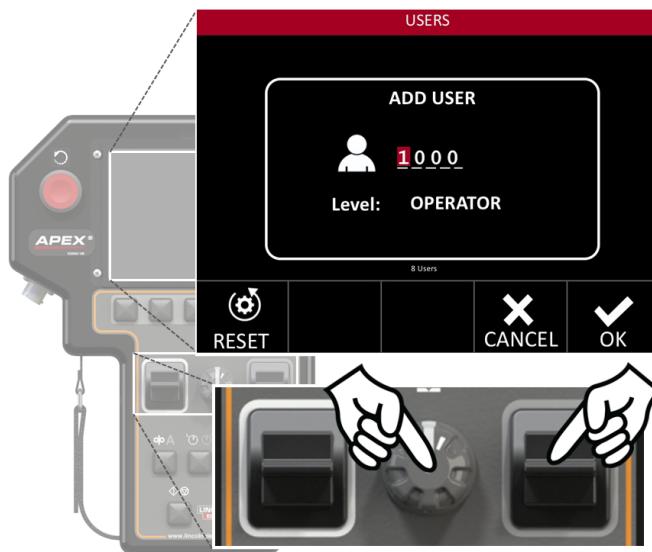

Changes the location of the cursor

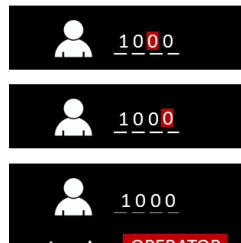

Once you have chosen the appropriate User code and level of access, select OK. Reset will change characters back to “0000”.

Deleting Users

Press the Delete Selection Button after selecting a user from the list.

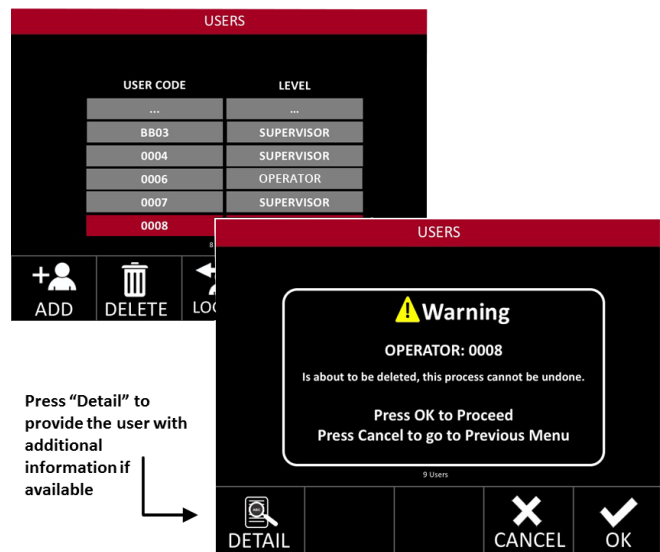

Deleting a user account will bring up a warning screen. Press the Detail Selection button to see more information about the shown screen.

CAUTION: DELETING ALL SUPERVISORS WILL REQUIRE A FACTORY RESET. PLEASE CONTACT THE FACTORY FOR INSTRUCTIONS.

The warning screen allows the user the chance to review what is being deleted. It also shows the level of access and the user code. The example on page B-27 shows OPERATOR:0008. If this User Code had supervisory access the screen would read: SUPERVISOR:0008.

If there are too many users to fit on the screen, the last box will contain ellipses – see **FIGURE 38 - Multiple Users**. This indicates that there are additional system users and the table will scroll to access each one. At the bottom of the fields it will tell how many user codes are currently listed in the system.

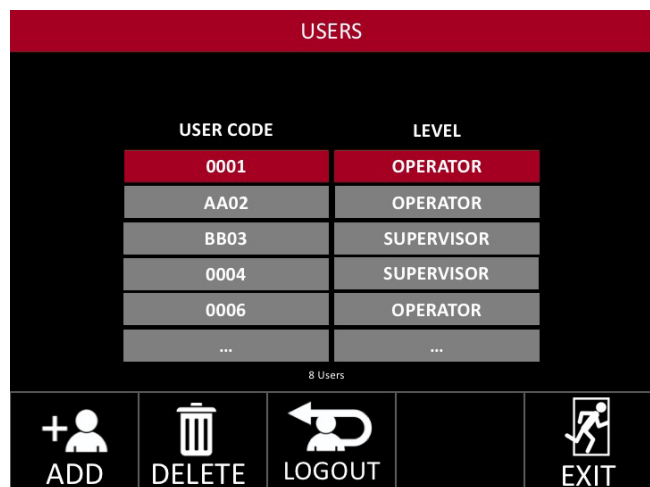

FIGURE 38 - Multiple Users

Changing User Access

To change the level of access that a user has been granted press the ADD selection button. Instead of entering a unique user code add in the existing user code that needs to be changed. With “Level” highlighted, choose the new access level.

Log Out

To change users, press the Logout Selection button. This logs out the current user so that a new user can log in.



Note: If the new user code is set as an operator they will not have full access to the system settings. Be sure to always have at least one supervisor code at all times for full system access.

Operator Log In

When an operator logs into the pendant they are presented with the program screen – see **FIGURE 39 - Operator Log In**.

PROGRAMS		
NAME	LEVEL	LOCATION
DEMO	Program Base (4)	Local
1STT	Program Base (3)	Local
2HOT	Program Pass	Local
3FILL	Program Pass	Local
4CAP	Program Pass	Local
STT ROOT	Independent Pass	Local
6 Program Items		
LOAD		EXIT

FIGURE 39 - Operator Log In

Since operators cannot save, delete, or create programs, they are presented with the program options available to them. They can select only these programs.

When entering setup mode, operators are automatically brought to the Programs Screen.

Increments Settings

The increments screen – see **FIGURE 40 - Increments Screen** – is used to set how much a single button press will change each value and limit the operator’s access to certain parameters.

The system minimum and maximum values provided to the user are based on the welding power source, weld mode, wire diameter and other factors.

The **increment options** that can be set are:

- Wire Feed Speed
- Amperage
- Voltage or Trim (depending on Weld Mode)
- Travel Speed
- Oscillation Width
- Oscillation Speed
- Dwell Time

Each of these values can have a minimum and maximum value set that the operator will not be able to exceed. These increments can be set per program and per pass.

To reset all increments back to their widest tolerance press the Reset Selection button.

Operator limitations also include the ability to set the system units between Imperial to Metric, which can only be performed by a supervisor.

If a multipass program is loaded, pressing the sector button (see button number 14 below) will advance to the next pass. This allows the user to quickly set the limits and increments for each pass.



DEMO/3FILL		
INCREMENT	MINIMUM	MAXIMUM
1	75	680
0.01	0.50	1.50
0.1	0.0	500.0
0.1	0.0	100.0
0.01	0.01	2.04
0.1	2.0	100.0
0.01	0.00	10.00
RESET	UNITS	EXIT

FIGURE 40 - Increments Screen

Refer to **page B-29** for a complete list of increment values for both imperial and metric measurements.

SETUP SCREEN	VALUE NAME	IMPERIAL INCREMENTS	METRIC INCREMENTS
INCREMENTALS & LIMITS MENU			
	Wire Speed	ipm	cm/min
	Voltage	Volts	Volts
	Amperage	Amps	Amps
	Travel Speed	ipm	cm/min
	Oscillation Width	inches	centimeters
	Oscillation Speed	ipm	cm/min
	Oscillation Dwell	seconds	seconds
START SETTINGS MENU			
	Preflow	seconds	seconds
	Upslope	seconds	seconds
	Runin Wire Feed Speed	ipm	cm/min
	Runin Voltage	Volts	Volts
	Motion Delay	seconds	seconds
END SETTINGS MENU			
	Crater Wire Feed Speed	ipm	cm/min
	Crater Voltage	Volts	Volts
	Crater Time	seconds	seconds
	Burnback	seconds	seconds
	Downslope	seconds	seconds
	Postflow	seconds	seconds
PROCESS SETUP MENU			
	Wire Feed Speed	ipm	cm/in
	Voltage	Volts	Volts
	Amperage	Amps	Amps
	Travel Speed	ipm	cm/min
	Oscillation Width	inches	centimeters
	Oscillation Speed	ipm	cm/min
	Left Dwell	seconds	seconds
	Right Dwell	seconds	seconds

Programs

From the program screen – see **FIGURE 41- Programs Screen** – programs can be saved into the system or onto a USB memory stick.

Fast Movement

Fast movement using the steering knob is enabled on this screen. Use the steering knob or left and right toggles for navigation and selection.

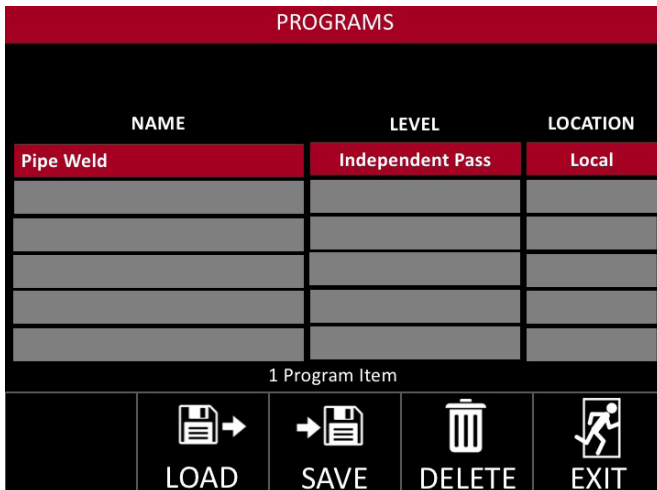

FIGURE 41 - Programs Screen

Saving an Independent Pass

A supervisor can change the parameters of the loaded program. Once the parameters are changed, they can be saved as a new program.

Pressing the save selection button will take the user to a sub-menu. This menu will allow the user to program the following variables:

Location: Selects where the program is saved

- Local: This saves directly to the Pendant
- USB: This saves to the installed USB. This option only appears when a USB is plugged in.

Level: Selects what type of Program is being saved

- Independent Pass - stand alone weld procedures, not tied to any other program
- Program Base - The first step in creating multiple passes which tie together to form a full welding procedure; this is explained in the next section.
- Program Pass - These are tied to the Program Base and can be created as needed by the user. For example a pipe could require four passes, so each pass could be saved under a Program Base for easy retrieval

Pass Name: Allows the user to select a unique pass name to identify the pass or program.

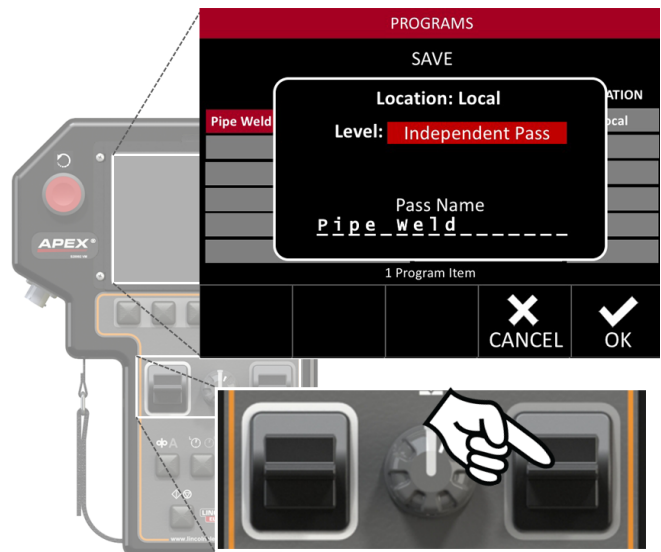

Switches between Program Base & Independent Pass



Once the location and level are set, a unique name is given to the program. This name should be distinct to prevent confusion.

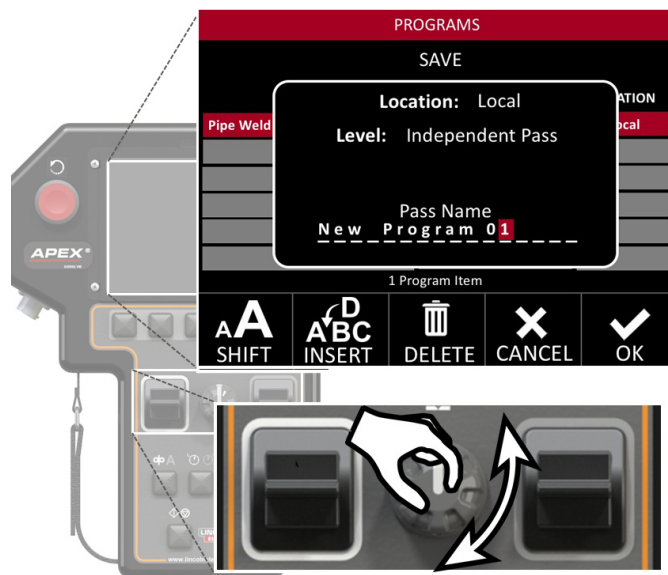

Note: Saving to a USB limits the program to 8 characters. The name field always auto populates with the name for the currently loaded program or the program name selected when the save button was pushed.

PROGRAMS		
Program Save Succeeded		
NAME	LEVEL	LOCATION
New Program 01	Independent Pass	Local
Pipe Weld	Independent Pass	Local
2 Program Items		
LOAD	SAVE	DELETE
EXIT		

Saving a Program Base

If there are multiple passes within the same procedure, setting up a Program Base is recommended.

In the save program sub-menu, change the level from Independent Pass to Program Base.

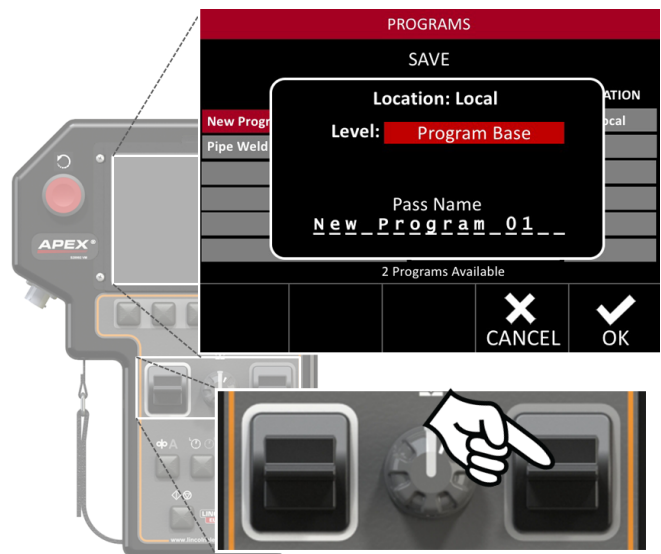

Switches between Program Base & Independent Pass



PROGRAMS		
Program Root Saved		
NAME	LEVEL	LOCATION
New Program 01	Independent Pass	LOCAL
Pipe Weld	Independent Pass	LOCAL
Steel 2in Pipe	Program Base(0)	LOCAL
3 Programs Available		
LOAD	SAVE	DELETE
EXIT		

Saving a Program Pass

Once a program base is saved, the next step is to create individual passes within the Program Base for the settings to be saved.

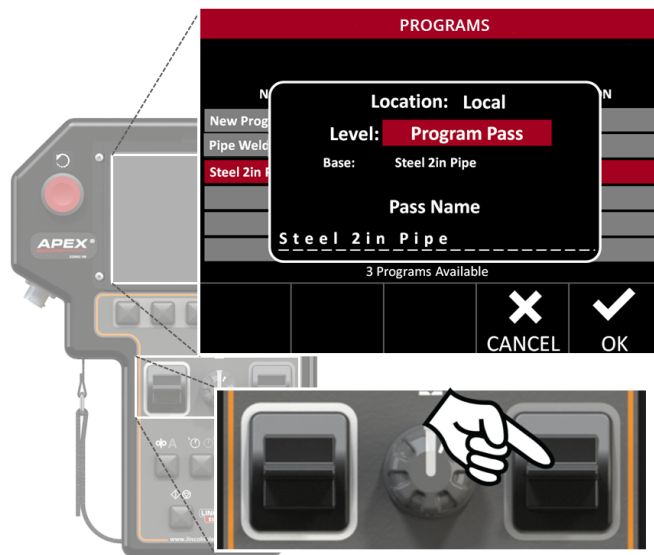

Switches between Independent Pass, Program Base, Program Pass and Program Update

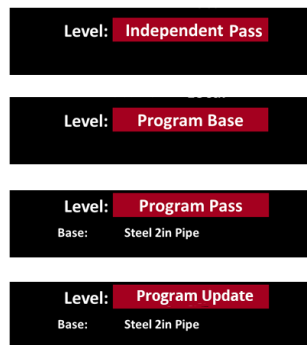

For this example the pass has been named 1Root. Continue to save programs to this base until the required passes are all saved.

After saving the required passes they are all displayed under the base – see **FIGURE 42 – Full Program Base**. Pressing the steering knob will expand the program base.

PROGRAMS		
Program Save Succeeded		
NAME	LEVEL	LOCATION
New Program 01	Independent Pass	LOCAL
Pipe Weld	Independent Pass	LOCAL
Steel 2in Pipe	Program Base(3)	LOCAL
1Root	Program Pass	LOCAL
2Fill	Program Pass	LOCAL
3Cap	Program Pass	LOCAL
6 Programs Available		
COPY	LOAD	SAVE
DELETE	EXIT	

FIGURE 42 - Full Program Base

Saving Program Updates

A fourth level selection, Program Update is available when changes are made to Program Passes associated with a Program Base.

When changes have been made to one or more Program Passes, the Program Base containing the changed Program Passes is selected and the SAVE button is pressed, the Program Update option becomes available on the SAVE screen.

If changes were made to one or all of the Program Passes associated with the Program Base “Steel 2in Pipe”, selecting the Program Base and pressing the SAVE button would product the following screen:

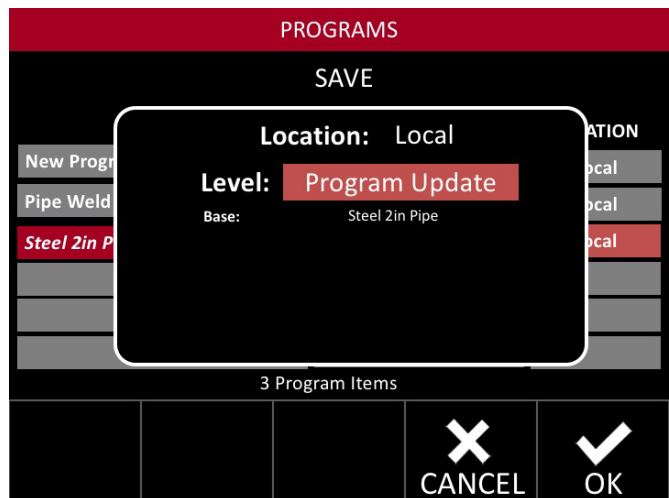

Selecting Program Update and pressing the OK button on this screen will save the changes made to all Program Passes at one time rather than requiring each Program Pass to be saved separately.

PROGRAMS		
Program Save Succeeded		
NAME	LEVEL	LOCATION
New Program 01	Independent Pass	LOCAL
Pipe Weld	Independent Pass	LOCAL
Steel 2in Pipe	Program Base(1)	LOCAL
1Root	Program Pass	LOCAL
4 Programs Available		
LOAD	SAVE	DELETE
EXIT		

Hide Program Passes

The passes in a program base can be hidden by highlighting the program base and pressing the steering knob, collapsing the group. Press the steering knob again and it will expand.

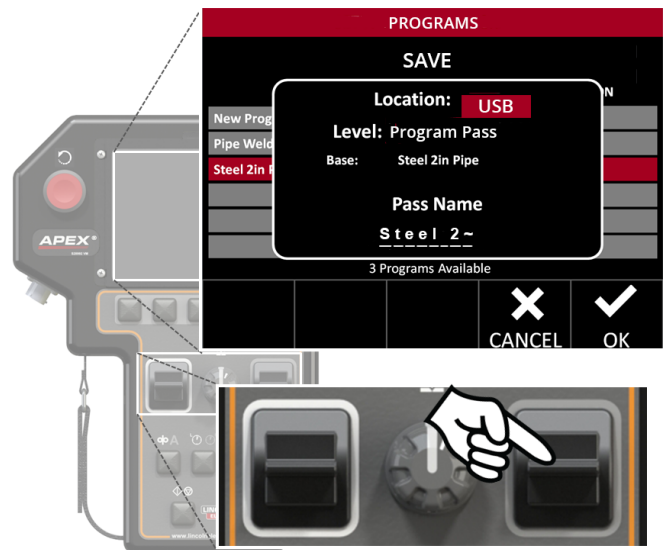
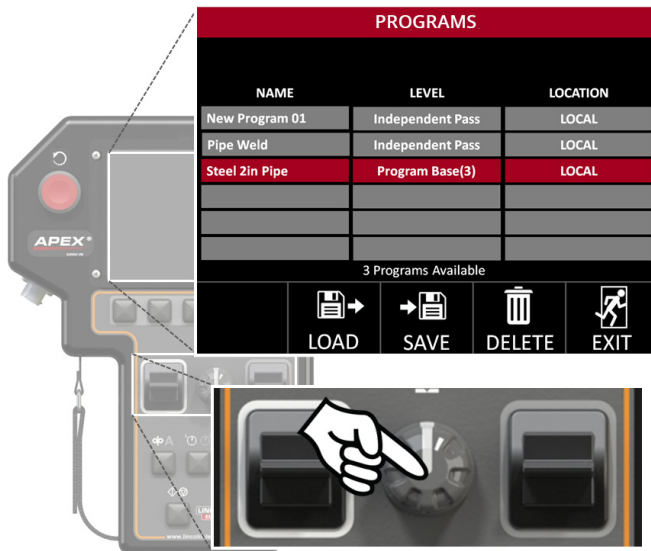

Switches between USB & Local

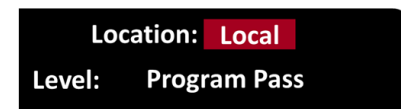

Saving to a USB

All of the examples shown have been saved locally to the pendant. They can also be saved to a USB.

The USB has a folder set up specially to save or read files. If this folder is missing then a prompt will appear on the screen – see **FIGURE 43 - USB Folder Notification**. If the flash drive is new, the system will create a folder.

To access files already saved on the USB, move them to the specified directory.

Note: A USB file name is restricted to 8 characters. Local files can be up to 16 characters. The only program name blocked is "Lincoln".



FIGURE 43 - USB Folder Notification

Copy to/from USB

With the USB inserted, a Copy Icon appears in the bottom left of the screen - see **FIGURE 44 - Copy Icon**.

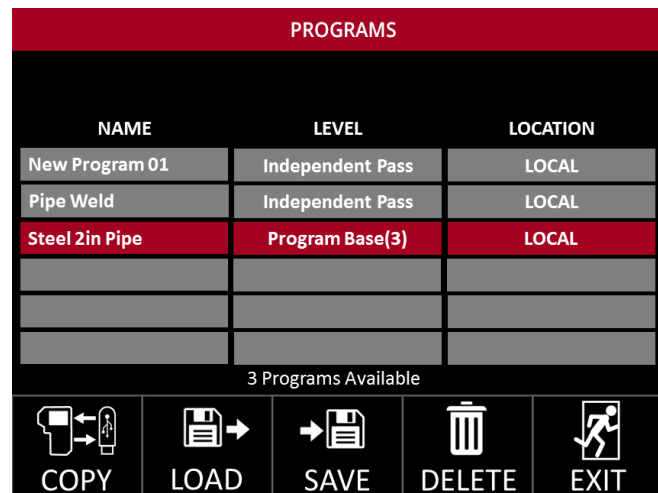

FIGURE 44 - Copy Icon

Press the Copy Selection Button.

A copy of the selected program is made – see **FIGURE 45, page B-34 – Copy to USB**

If the file is currently saved on the USB, it will save to the Pendant, if it is a Local file (saved to the pendant), it will save to USB.

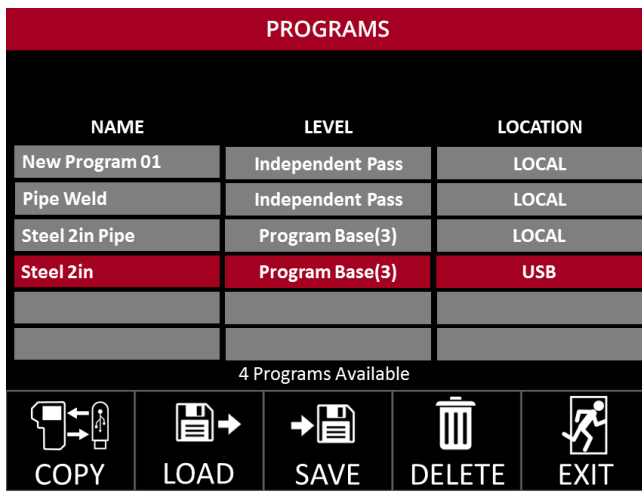

FIGURE 45 - Copy to USB

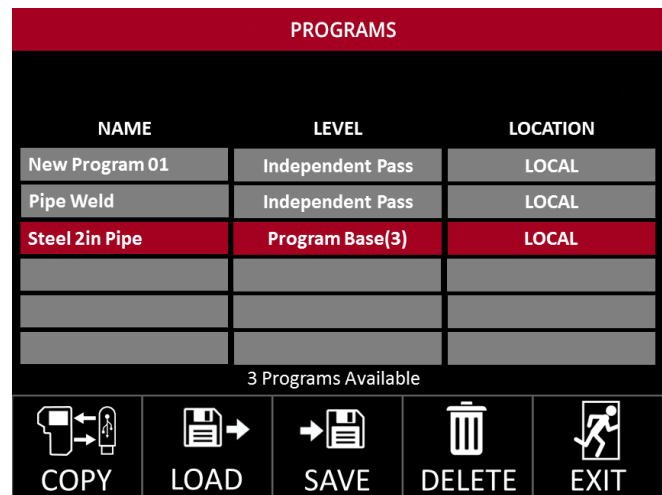

FIGURE 47 - Loading Program

Note: If a locally saved program has more than 8 characters, copying to a USB will truncate it to the first 7 characters of the original name and a tilde (~) to indicate that it's shortened. To save with a unique name, load the program and then manually save to the USB with the desired 8-character name.

Deleting a Program Base

If a Program Base is deleted then all associated passes are also deleted.

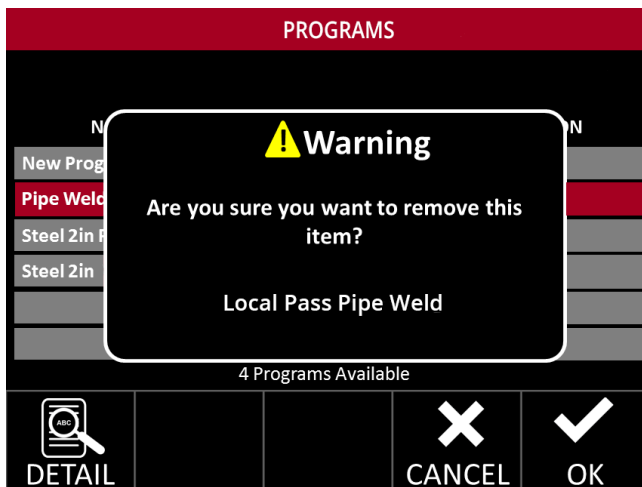

FIGURE 46 - Program Delete

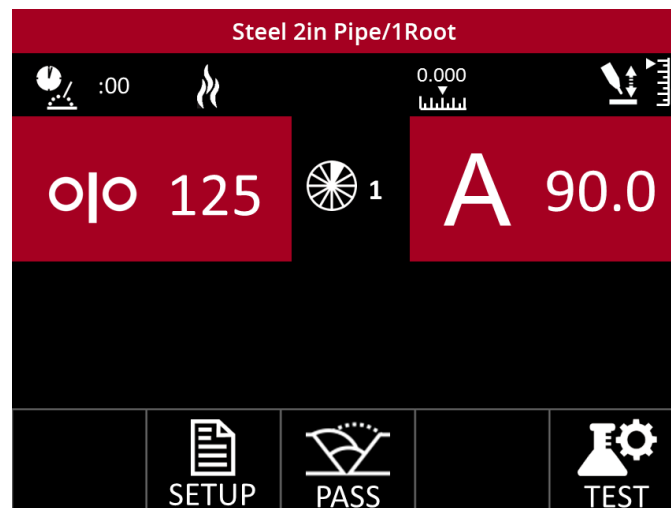

FIGURE 48 - Loaded Program

Deleting a Program

Saved programs can be deleted by highlighting the program and pressing the Delete Selection button. This will bring up a new window – see **FIGURE 46- Program Delete**.

Press the Delete Selection Button.

Loading a Program

Go to the Programs Menu to load the relevant program. Highlight the program or base.

Press the Load Selection button. This will load the applicable program. See **FIGURE 47 Loading Program**

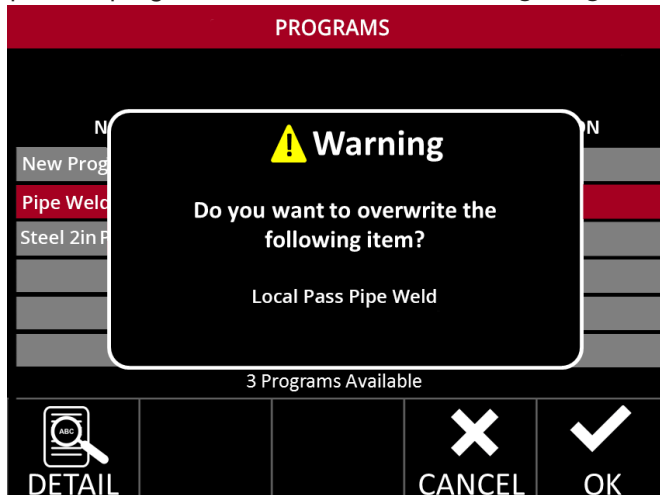

and **FIGURE 48 - Loaded Program.**

Overwriting a Program

Saving a file with the same name will overwrite the existing program. The system gives a warning that the existing program will be overwritten. Overwriting will delete the original program.

STANDARD PIPING SCHEDULE CHART

OD in	OD mm	Schedule	Wall in	Wall mm	ID in	ID mm
1/8 0.405	10.3	105	0.049	1.24	0.307	7.8
		40ST, 40S	0.068	1.73	0.269	6.83
		80SX, 80S	0.095	2.41	0.215	5.46
1/4 0.54	13.7	105	0.065	1.65	0.41	10.41
		40ST, 40S	0.088	2.24	0.364	9.25
		80SX, 80S	0.119	3.02	0.302	7.67
3/8 0.675	17.1	105	0.065	1.65	0.545	13.84
		40ST, 40S	0.091	2.31	0.493	12.52
		80SX, 80S	0.126	3.2	0.423	10.74
1/2 0.84	21.3	55	0.065	1.65	0.71	18.03
		105	0.083	2.11	0.674	17.12
		40ST, 40S	0.109	2.77	0.622	15.8
3/4 1.05	26.7	105	0.147	3.73	0.546	13.87
		40ST, 40S	0.188	4.78	0.464	11.79
		80SX, 80S	0.294	7.47	0.252	6.4
1 1.315	33.4	55	0.065	1.65	1.185	30.1
		105	0.109	2.77	1.097	27.86
		40ST, 40S	0.133	3.38	1.049	26.64
1 1/4 1.66	42.2	105	0.179	4.54	0.957	24.31
		40ST, 40S	0.25	6.35	0.815	20.7
		80SX, 80S	0.358	9.09	0.599	15.21
1 1/2 1.9	48.3	55	0.065	1.65	1.53	38.86
		105	0.109	2.77	1.442	36.63
		40ST, 40S	0.14	3.56	1.38	35.05
2 2.375	60.3	105	0.191	4.85	1.278	32.46
		40ST, 40S	0.25	6.35	1.16	29.46
		80SX, 80S	0.382	9.7	0.896	22.76
2 1/2 2.875	73	55	0.065	1.65	1.77	44.96
		105	0.109	2.77	1.682	42.72
		40ST, 40S	0.133	3.38	1.61	40.89
3 3.5	88.9	105	0.2	5.08	1.5	38.1
		40ST, 40S	0.281	7.14	1.338	33.99
		80SX, 80S	0.4	10.16	1.1	27.84
3 1/2 4	101.6	55	0.065	1.65	2.245	57.02
		105	0.109	2.77	2.157	54.79
		40ST, 40S	0.154	3.91	2.067	52.5
4 4.5	114.3	105	0.218	5.54	1.939	49.25
		40ST, 40S	0.344	8.74	1.687	42.85
		80SX, 80S	0.436	11.07	1.503	38.18
5 5.563	141.3	55	0.083	2.11	2.709	68.81
		105	0.12	3.05	2.635	66.93
		40ST, 40S	0.203	5.16	2.469	62.71
6 6.625	168.3	105	0.276	7.01	2.323	59
		40ST, 40S	0.375	9.53	2.125	53.98
		80SX, 80S	0.552	14.02	1.771	44.98
8 8.625	219.1	55	0.083	2.11	3.334	84.68
		105	0.12	3.05	3.26	82.8
		40ST, 40S	0.216	5.49	3.068	77.93
10 10.75	273	105	0.3	7.62	2.9	73.66
		40ST, 40S	0.438	11.13	2.624	66.65
		80SX, 80S	0.6	15.24	2.3	58.42
12 12.75	323.8	55	0.083	2.11	3.934	97.38
		105	0.12	3.05	3.76	95.5
		40ST, 40S	0.226	5.74	3.548	90.12
14 14	355.6	105	0.318	8.08	3.364	85.45
		40ST, 40S	0.438	11.13	3.264	83.6
		80SX, 80S	0.6	15.24	2.9	73.66
16 16	406.4	55	0.083	2.11	4.334	110.1
		105	0.12	3.05	4.26	108.2
		40ST, 40S	0.237	6.02	4.026	102.3
18 18	457	105	0.337	8.56	3.826	97.2
		40ST, 40S	0.438	11.13	3.624	92
		80SX, 80S	0.6	15.24	3.264	83.6
20 20	508	55	0.083	2.11	4.334	97.38
		105	0.12	3.05	4.26	108.2
		40ST, 40S	0.237	6.02	4.026	102.3
24 24	610	105	0.337	8.56	3.826	97.2
		40ST, 40S	0.438	11.13	3.624	92
		80SX, 80S	0.6	15.24	3.264	83.6
30 30	762	55	0.083	2.11	4.334	97.38
		105	0.12	3.05	4.26	108.2
		40ST, 40S	0.237	6.02	4.026	102.3

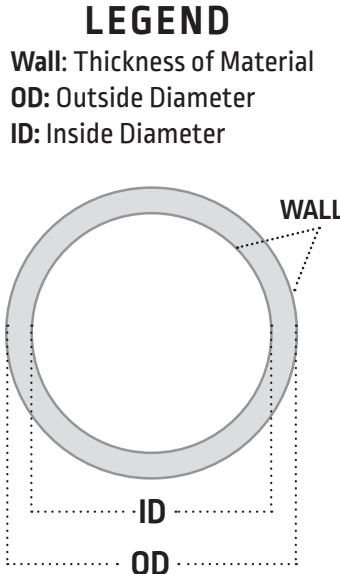

OD in	OD mm	Schedule	Wall in	Wall mm	ID in	ID mm
10 10.75	273	55	0.134	3.4	10.482	266.2
		105	0.165	4.19	10.42	264.7
		20	0.25	6.35	10.25	260.4
		30	0.307	7.8	10.136	257.5
		40ST, 40S	0.365	9.27	10.02	254.5
		60XS, 80S	0.5	12.7	9.75	247.7
		80	0.594	15.09	9.562	242.9
		100	0.719	18.26	9.312	236.5
		120	0.844	21.44	9.062	230.2
		140, XX	1	25.4	8.75	222.3
160	1.12	28.58	8.5	215.9		
12 12.75	323.8	55	0.156	3.96	12.438	315.9
		105	0.18	4.587	12.39	314.7
		20	0.25	6.35	12.25	311.2
		30	0.33	8.38	12.09	307.1
		40ST, 40S	0.375	9.53	12	304.8
		60XS, 80S	0.406	10.31	11.938	304.2
		80	0.5	12.7	11.75	298.5
		100	0.562	14.27	11.626	295.3
		120	0.688	17.48	11.374	288.9
		140	0.844	21.44	11.062	281
160	1	25.4	10.75	273.1		
180	1.125	28.58	10.5	266.7		
200	1.312	33.32	10.126	257.2		
14 14	355.6	55	0.156	3.96	13.688	347.7
		105	0.188	4.78	13.624	346
		20	0.25	6.35	13.5	342.9
		30	0.312	7.92	13.376	339.8
		40ST, 40S	0.375	9.53	13.25	336.6
		60XS, 80S	0.438	11.13	13.124	333.3
		80	0.5	12.7	13	330.2
		100	0.594	15.09	12.812	325.4
		120	0.75	19.05	12.5	317.5
		140	0.938	23.83	12.124	308
160	1.094	27.79	11.812	300		
180	1.25	31.75	11.5	292.1		
200	1.406	35.71	11.188	284.2		
16 16	406.4	55	0.165	4.19	15.67	398
		105	0.188	4.78	15.624	396.8
		20	0.25	6.35	15.5	393.7
		30	0.312	7.92	15.376	390.6
		40ST, 40S	0.375	9.53	15.25	387.4
		60XS, 80S	0.5	12.7	15	381
		80	0.594	15.09	14.688	373.1
		100	0.75	19.05	14.312	363.5
		120	0.938	23.83	13.938	354
		140	1.125	28.58	13.562	344.5
160	1.312	33.32	13.124	333.3		
180	1.594	40.49	12.812	325.4		
18 18	457	55	0.165	4.19	17.67	449
		105	0.188	4.78	17.624	448
		20	0.25	6.35	17.5	445
		30	0.312	7.92	17.376	441
		40ST, 40S	0.375	9.53	17.25	438
		60XS, 80S	0.438	11.13	17.124	435
		80	0.5	12.7	17	432
		100	0.562	14.27	16.876	429
		120	0.75	19.05	16.5	419
		140	0.938	23.83	16.124	410
160	1.156	29.36	15.688	398		
180	1.375	34.93	15.25	387		
200	1.562	39.67	14.876	378		
220	1.781	45.24	14.438	367		
20 20	508	55	0.188	4.78	19.624	498
		105	0.218	5.54	19.564	497
		20	0.25	6.35	19.5	495
		30	0.312	7.92	19.376	491
		40ST, 40S	0.375	9.53	19.25	489
		60XS, 80S	0.5	12.7	19	483
		80	0.594	15.09	18.812	478
		100	0.812	20.62	18.376	467
		120	1.031	26.19	17.938	456
		140	1.281	32.54	17.438	443
160	1.5	38.1	17	432		
180	1.75	44.45	16.5	419		
200	1.969	50.01	16.062	408		
24 24	610	55	0.218	5.54	23.564	599
		105	0.25	6.35	23.5	597
		20	0.375	9.53	23.25	591
		30	0.5	12.7	23	584
		40ST, 40S	0.562	14.27	22.876	581
		60XS, 80S	0.688	17.48	22.624	575
		80	0.969	24.61	22.062	560
		100	1.218	30.96	21.562	548
		120	1.531	38.89	20.938	532
		140	1.812	46.02	20.376	518
160	2.062	52.37	19.876	505		
180	2.344	59.54	19.312	491		
30 30	762	55	0.25	6.35	29.5	749
		105	0.312	7.92	29.376	746
		20	0.375	9.53	29.25	743
		30	0.5	12.7	29	737
		40ST, 40S	0.625	15.88	28.75	730

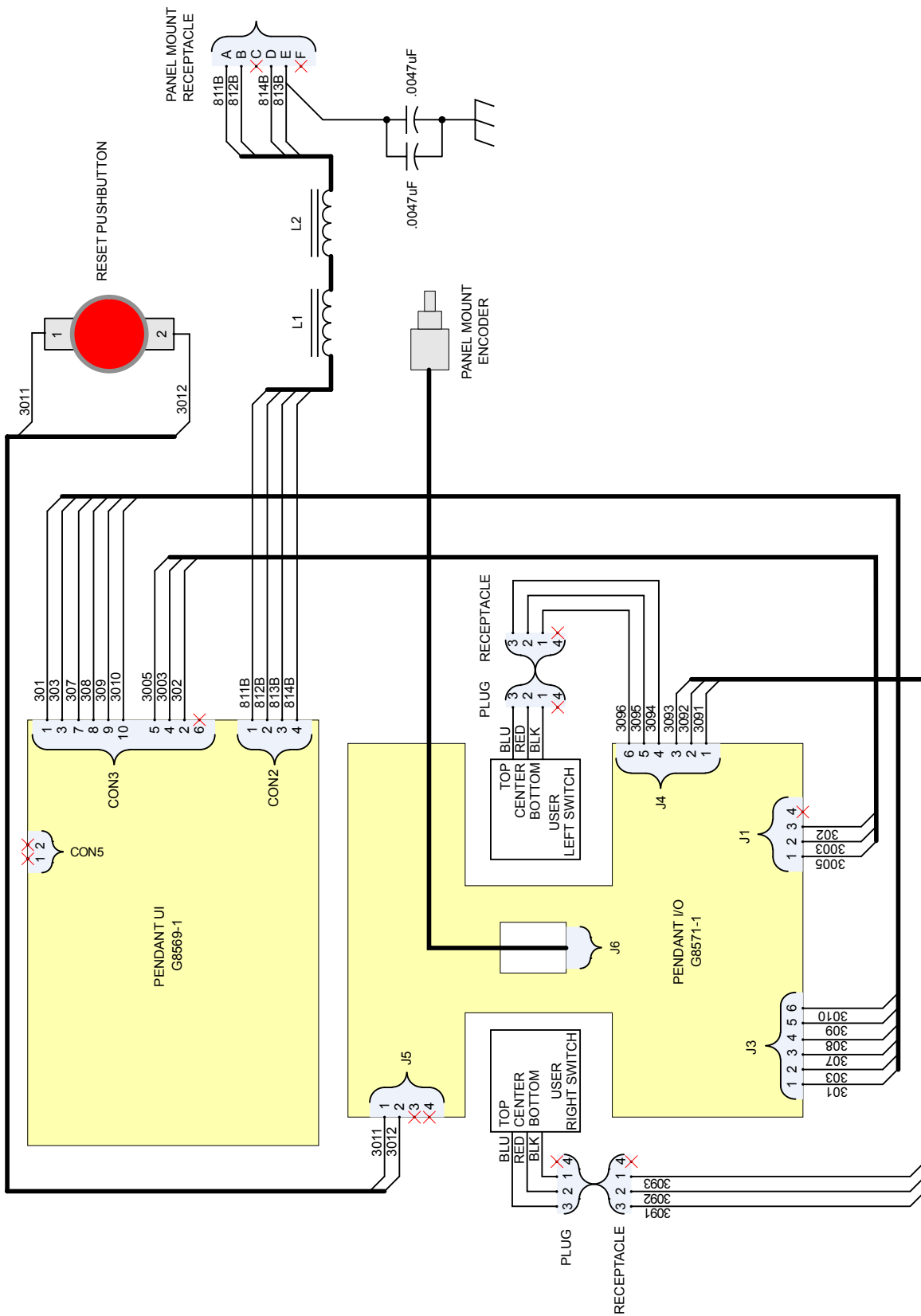

NOTE: This diagram is for reference only. It may not be accurate for all machines covered by this manual. The specific diagram for a particular code is pasted inside the machine on one of the enclosure panels. If the diagram is illegible, write to the Service Department for a replacement. Give the equipment code number.

APEX® 3 SERIES MIG PENDANT PARTS

This parts list is provided as an informative guide only.

APEX® 3 Series MIG Pendant

For Codes: 70313, 12833

Do not use this Parts List for a machine if its code number is not listed. Contact the Service Department for any code numbers not listed.

Use the illustration of Sub-Assemblies page and the table below to determine which sub assembly page and column the desired part is located on for your particular code machine.

Sub Assembly Item Number →	1	2	3	4	5	6	7
SUB ASSEMBLY PAGE NAME →	APEX 3 Series Pendant						
PAGE NO. →	40						
CODE NO. ↓							
70313	1						
12833	2						

11-07-18

NOTE: This Parts Manual is provided as an informative guide only. When ordering parts always refer to the Lincoln Electric Parts List.

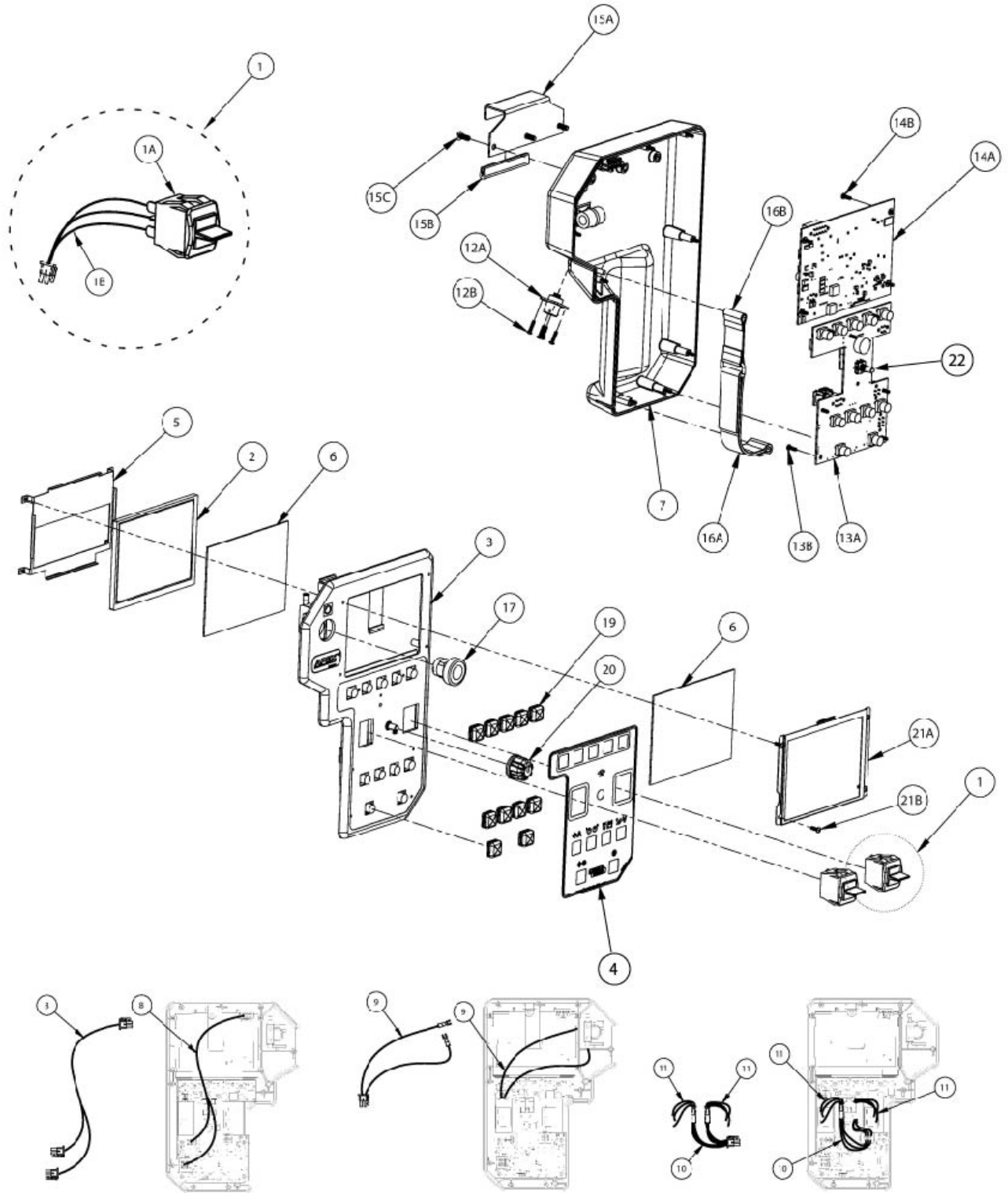

NOTE: This Parts Manual is provided as an informative guide only. When ordering parts always refer to the Lincoln Electric Parts List.

Indicates a change in this printing.

Use only the parts marked "X" in the column under the heading number called for in the model index page.

ITEM	DESCRIPTION	PART NO.	QTY	1	2
1	Rocker Switch & Harness Assembly, includes:	9SS30720	2	X	X
1A	Rocker Switch	9SS30493	2	X	X
1B	Harness Assembly	NSS	2	X	X
2	Color LCD	9SS29390	1	X	X
3	Pendant Top	9SM23062-2	1	X	X
4	Pendant Overlay	9SS30292	1	X	X
5	Screen Holder	9SM24594	1	X	X
6	Screen Protector	9SS30712	2	X	X
7	Pendant Bottom (Includes item 12)	9SM23063	1	X	X
8	UI to IO Link Harness	9SS30398	1	X	X
9	Pendant Estop Harness	9SS30399	1	X	X
10	Dual Rocker Switch PCB Harness	9SS30717	1	X	X
11	Pendant Rocker Switch Harness	9SS30720	2	X	X
12	Pendant Input Harness Assembly, includes:	9SS30458	1	X	X
12A	Pendant Input Harness	NSS	1	X	X
12B	Screw	NSS	4	X	X
13	I/O PCB Assembly, includes:	9SS30302	1	X	•
13	I/O PCB Assembly, includes:	9SS31339	1	•	X
13A	I/O PCB	NSS	1	X	X
13B	Screw	NSS	4	X	X
14	User Interface PCB Assembly, includes:	9SS30300	1	X	•
14	User Interface PCB Assembly, includes:	9SS32531	1	•	X
14A	User Interface PCB	NSS	1	X	X
14B	Screw	NSS	7	X	X
15	Pendant Hook Assembly, includes:	9SS29560-22	1	X	X
15A	Pendant Hook	NSS	1	X	X
15B	Rubber Bumper	NSS	1	X	X
15C	Screw	NSS	3	X	X
16	Pendant Strap Assembly, includes:	9SS29560-21	1	X	X
16A	Pendant Strap A	NSS	1	X	X
16B	Pendant Strap B	NSS	1	X	X
17	Pushbutton Operator	9SS29987	1	X	X
19	Button Cover Small	9SS23055-1	11	X	X
20	Knob	9SM22778-1	1	X	X
21	Spatter Shield Pocket Assembly, includes:	9SM23325	1	X	X
21A	Spatter Shield Pocket	NSS	1	X	X
21B	Screws	NSS	4	X	X
22	Optical Encoder	9SS32527	1	•	X

NOTE: This Parts Manual is provided as an informative guide only. When ordering parts always refer to the Lincoln Electric Parts List.

CUSTOMER ASSISTANCE POLICY

The business of The Lincoln Electric Company is manufacturing and selling high quality welding equipment, consumables, and cutting equipment. Our challenge is to meet the needs of our customers and to exceed their expectations. On occasion, purchasers may ask Lincoln Electric for advice or information about their use of our products. We respond to our customers based on the best information in our possession at that time. Lincoln Electric is not in a position to warrant or guarantee such advice, and assumes no liability, with respect to such information or advice. We expressly disclaim any warranty of any kind, including any warranty of fitness for any customer's particular purpose, with respect to such information or advice. As a matter of practical consideration, we also cannot assume any responsibility for updating or correcting any such information or advice once it has been given, nor does the provision of information or advice create, expand or alter any warranty with respect to the sale of our products.

Lincoln Electric is a responsive manufacturer, but the selection and use of specific products sold by Lincoln Electric is solely within the control of, and remains the sole responsibility of the customer. Many variables beyond the control of Lincoln Electric affect the results obtained in applying these types of fabrication methods and service requirements.

Subject to Change – This information is accurate to the best of our knowledge at the time of printing. Please refer to www.lincolnelectric.com for any updated information.



THE LINCOLN ELECTRIC COMPANY

22801 St. Clair Avenue • Cleveland, OH • 44117-1199 • U.S.A.
Phone: +1.216.481.8100 • www.lincolnelectric.com