

MIG GUN BALANCED ARM (MGBA)

SUPPORT AND EXTEND
YOUR WORKING AREA



www.lincolnelectric.eu

LINCOLN[®]
ELECTRIC

OVERVIEW

MAIN FEATURES

- Perfect support arm for long and heavy MIG welding and fume extraction torches
- Improves access to hard-to-reach welding working areas
- Adjustable arm length
- Adjustable counterbalance spring
- Adjustable arm inclination angle
- Can be swiveled 360°
- Support and extend your working area
- Integrated welding torch holder
- Velcro strips for secure installation of the MIG welding torch
- Can be mounted easily to the power source, inverter cart or any stationary pedestal
- Increased ergonomics at the welding site thanks to less strain on the entire welding torch hose package
- Increased MIG gun service life

Suitable for:

- Speedtec® 400SP/500SP on the cart
- Powertec® i350S/i420S/i500S
- Digisteel S range
- Citosteel S range
- LF5D/LF52D/LF56D/WF52D/WF56D feeders



Technical Specification

Product Name	Product Number	Adjustable arm length		Angle of arm inclination	Swiveled
		Min.	Max.		
Mig Gun Balanced Arm (MGBA)	K14425-1	1.57m	2.72m	0° / 15° / 30° / 45°	360°

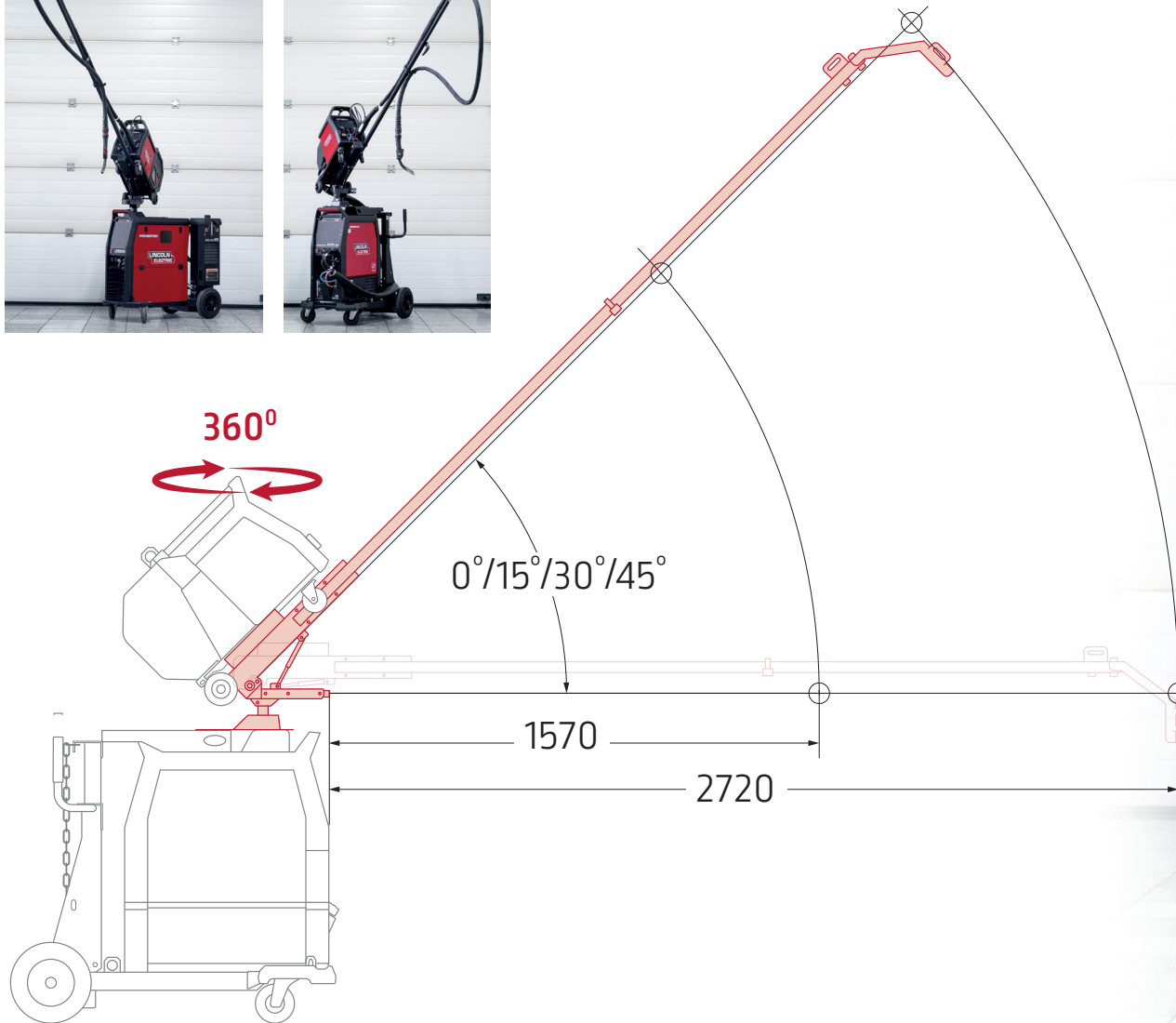

Welder has full parameter control from a distance when using the RC-7 Remote Control

CUSTOMER ASSISTANCE POLICY

The business of The Lincoln Electric Company® is manufacturing and selling high quality welding equipment, consumables, and cutting equipment. Our challenge is to meet the needs of our customers and to exceed their expectations. On occasion, purchasers may ask Lincoln Electric for information or advice about their use of our products. Our employees respond to enquiries to the best of their ability based on information provided to them by the customers and the knowledge they may have concerning the application. Our employees, however, are not in a position to verify the information provided or to evaluate the engineering requirements for the particular weldment. Accordingly, Lincoln Electric does not warrant or guarantee or assume any liability with respect to such information or advice. Moreover, the provision of such information or advice does not create, expand, or alter any warranty on our products. Any express or implied warranty that might arise from the information or advice, including any implied warranty of merchantability or any warranty of fitness for any customers' particular purpose is specifically disclaimed.

Lincoln Electric is a responsive manufacturer, but the selection and use of specific products sold by Lincoln Electric is solely within the control of, and remains the sole responsibility of the customer. Many variables beyond the control of Lincoln Electric affect the results obtained in applying these types of fabrication methods and service requirements.

Subject to Change – This information is accurate to the best of our knowledge at the time of printing. Please refer to www.lincolnelectric.eu for any updated information.



www.lincolnelectriceurope.com

