

FLEXTEC 450 WIRING DIAGRAM G6890-5 REV: A

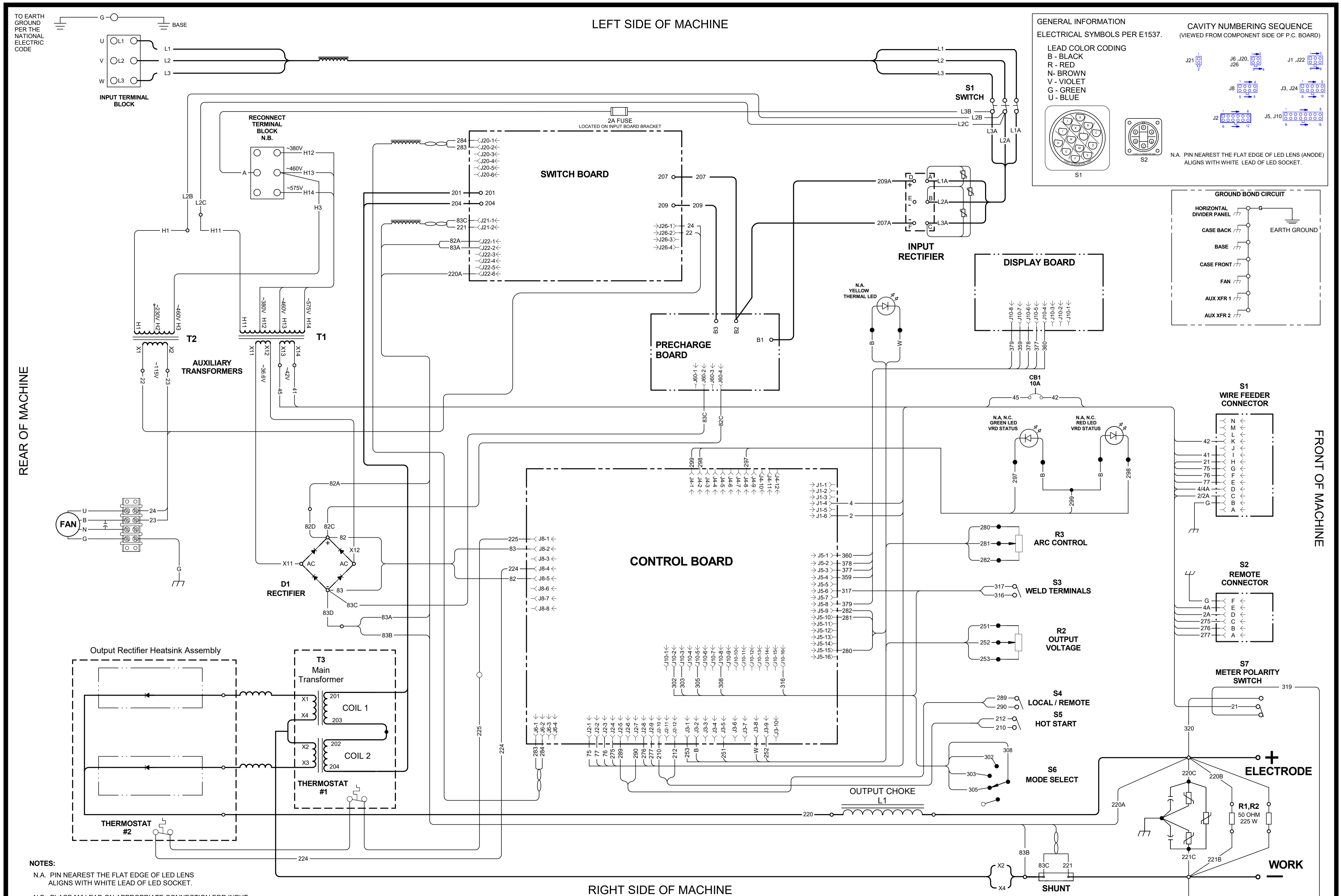

GENERAL INFORMATION
ELECTRICAL SYMBOLS PER E1537.

LEAD COLOR CODING
B - BLACK
R - RED
N - BROWN
V - VIOLET
G - GREEN
U - BLUE

CAVITY NUMBERING SEQUENCE
(VIEWED FROM COMPONENT SIDE OF P.C. BOARD)

N.A. PIN NEAREST THE FLAT EDGE OF LED LENS (ANODE) ALIGNS WITH WHITE LEAD OF LED SOCKET.

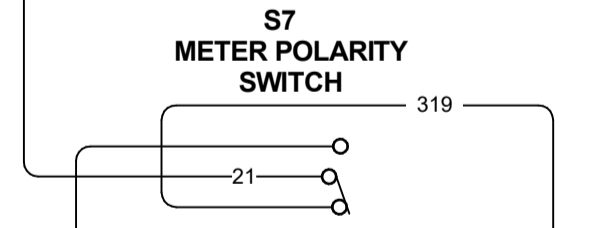
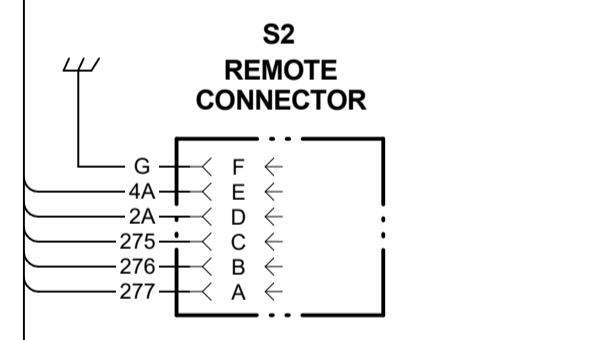
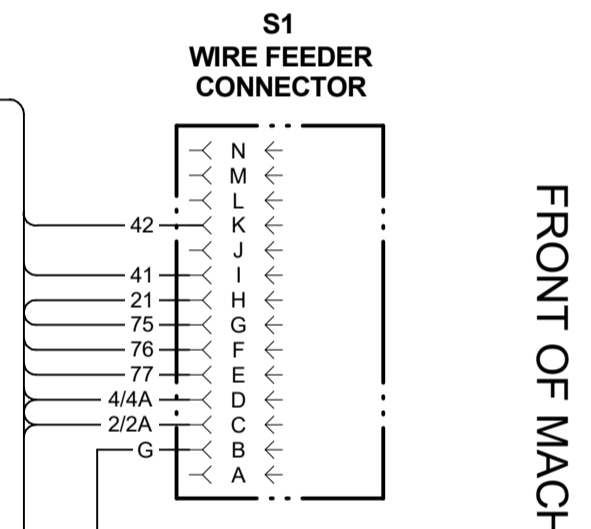
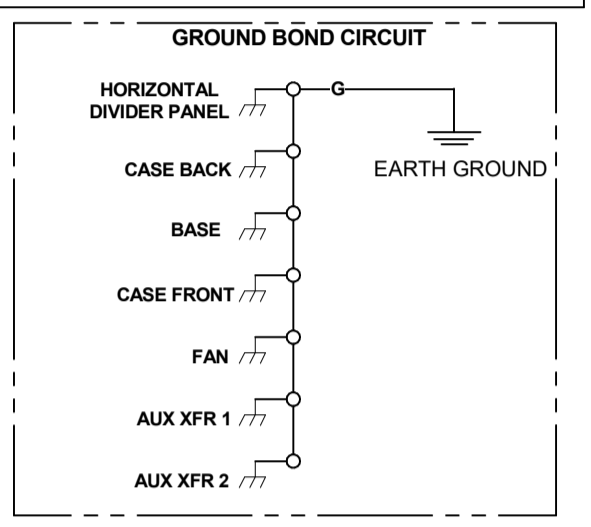

NOTES:
N.A. PIN NEAREST THE FLAT EDGE OF LED LENS ALIGNS WITH WHITE LEAD OF LED SOCKET.
N.B. PLACE "A" LEAD ON APPROPRIATE CONNECTION FOR INPUT VOLTAGE. CONNECTION SHOWN IS FOR 460 V OPERATION.
N.C. LED'S ARE ONLY ACTIVE IF VRD IS TURNED ON. TURN ON VRD BY PLACING DIP SWITCH 5 ON CONTROL BOARD IN THE "ON" POSITION.

LEFT SIDE OF MACHINE

RIGHT SIDE OF MACHINE

