



Connection Guide

HyperFill[®]



Authorized Service and Distributor Locator:
www.lincolnelectric.com/locator

Need Help? Call 1.888.935.3877
to talk to a Service Representative

Hours of Operation:
8:00 AM to 6:00 PM (ET) Mon. thru Fri.

After hours?
Use “Ask the Experts” at lincolnelectric.com
A Lincoln Service Representative will contact you
no later than the following business day.

For Service outside the USA:
Email: globalservice@lincolnelectric.com

Service Parts:
parts.lincolnelectric.com

For use with machines:

Power Wave[®] S500 (K2904-1)

Power Wave[®] S700 (K3279-1)

PipeFab[™] (K3734-1)

Table of Contents

HyperFill® (Twin-Wire)

Power Wave S500 and S700 Power Feed 84 Series

Inverter Cart Setup: HyperFill Cart Reel Kit w/ PF84 Single Feeder	3
Inverter Cart Setup: HyperFill Cart Reel Kit w/ PF84 Dual Feeder	4
Inverter Cart Setup: Bulk Wire	5
Undercarriage Setup: HyperFill Undercarriage Kit w/ PF84 Single Feeder	6
Undercarriage Setup: HyperFill Undercarriage Kit w/ PF84 Dual Feeder	7
Benchtop Setup: HyperFill Bench Kit w/ PF84 Single Feeder	8
Benchtop Setup: HyperFill Bench Kit w/ PF84 Dual Feeder	9

PIPEFAB™ w/PIPEFAB™ FEEDER

PipeFab w/PipeFab Feeder Set Up	10
---------------------------------------	----

Appendix

Gun Expendables	11
Wire Feeder Expendables	11

HYPERFILL (Twin-Wire)

Inverter Cart Setup: HyperFill Cart Reel Kit w/ PF84 Single Feeder

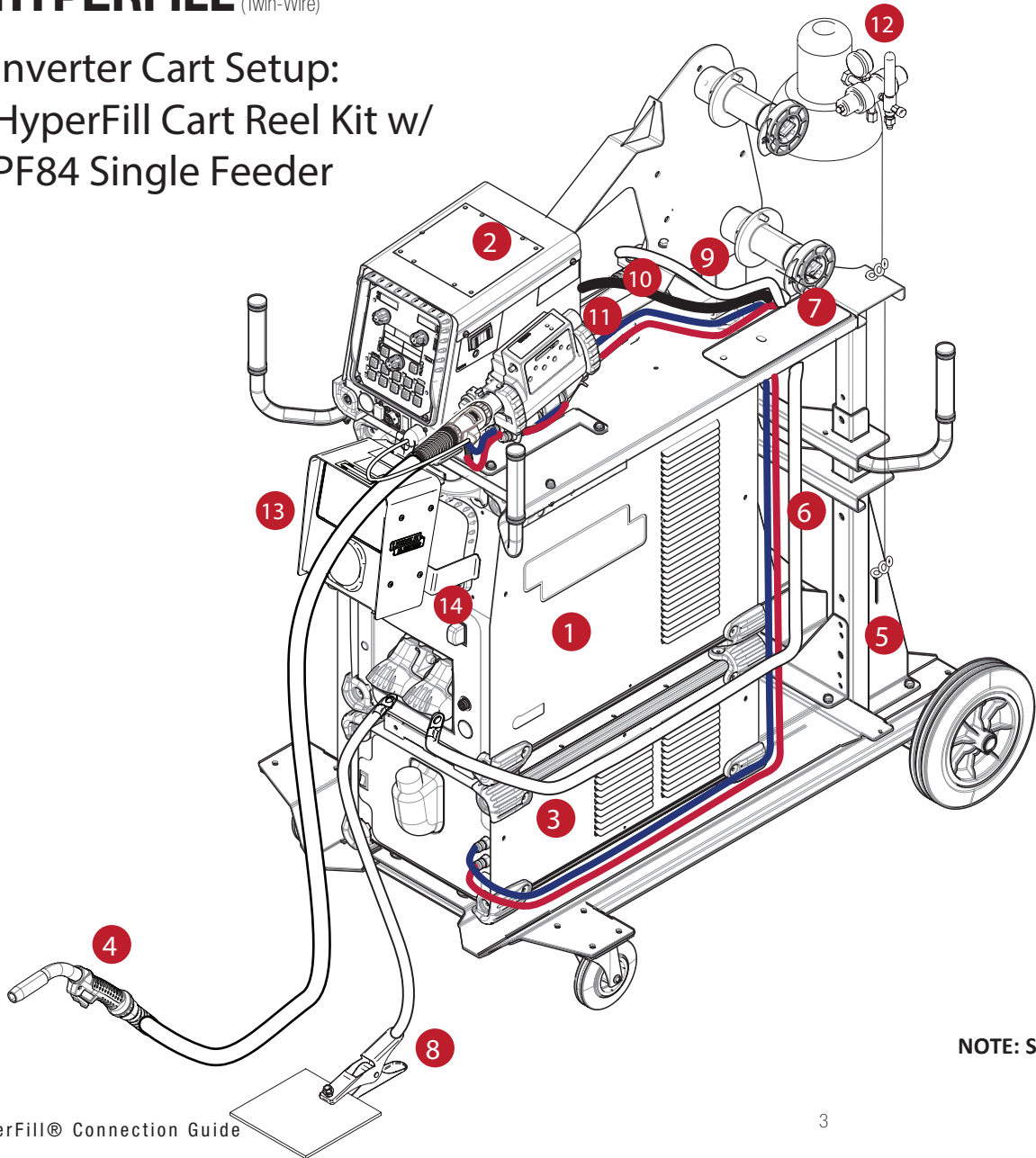

Item	Product Description	Part Number	Notes
1	Power Wave® S500	K2904-1	
2	Power Feed® 84 Bench Wire Feeder - U/I, No Reel, USB	K3328-1	Requires HyperFill Drive Roll Kit KP4388-X
	HyperFill™ Drive Roll Kit (.035" - .040" / 0.9 -1.0 mm)	KP4388-1	
3	Cool Arc® 55S <u>or</u> Cool Wave® 20S*	K3086-2 <u>or</u> K4713-1*	*Cool Wave® 20S required for S700
4	Magnum® PRO Water Cooled 500A Welding Gun	K4522-2-10-564	Requires HyperFill gun expendables
	HyperFill™ Diffuser	KP4481-1	
	HyperFill™ Contact Tip	KP4482-035 or KP4482-040	.035" (0.9mm) or .040" (1.0mm) Contact Tip
5	Inverter and Wire Feeder Cart	K3059-X	*K3059-4 for single bottlecart or K3059-5 for dual bottle cart
6	7 ft. Water Hose Kit	K4544-7	
7	HyperFill Cart Reel Kit	K4630-1	
8	Work Lead - Lug & GC500 Ground Clamp (3/0, 600A, 60%) 15 ft. (15.3 m)	K1842-XX* w/K910-2	*XX is application specific length
9	Weld Power Cable - Lug to Lug (3/0, 600A, 60%)	K1842-XX*	*XX is application specific length
10	Ext-Flex ArcLink®/Linc-Net® Control Cable	K4483-XX*	*XX is application specific length
11	4-Ball Roller Incoming Guide	K1551-2*	*Recommended
12	Harris® Flowmeter Regulator and Hose Kit	3100211	
13	Gateway Pendant (Includes 8ft ArcLink Cable)	K4997-1*	*Requires HyperFill Activation Card K4966-xx
14	Gateway Pendant Hanger Kit	* K5294-1	*Recommended

NOTE: See Page 11 for cooling capacity recommendations.

HYPERFILL (Twin-Wire)

Inverter Cart Setup: HyperFill Cart Reel Kit w/ PF84 Dual Feeder

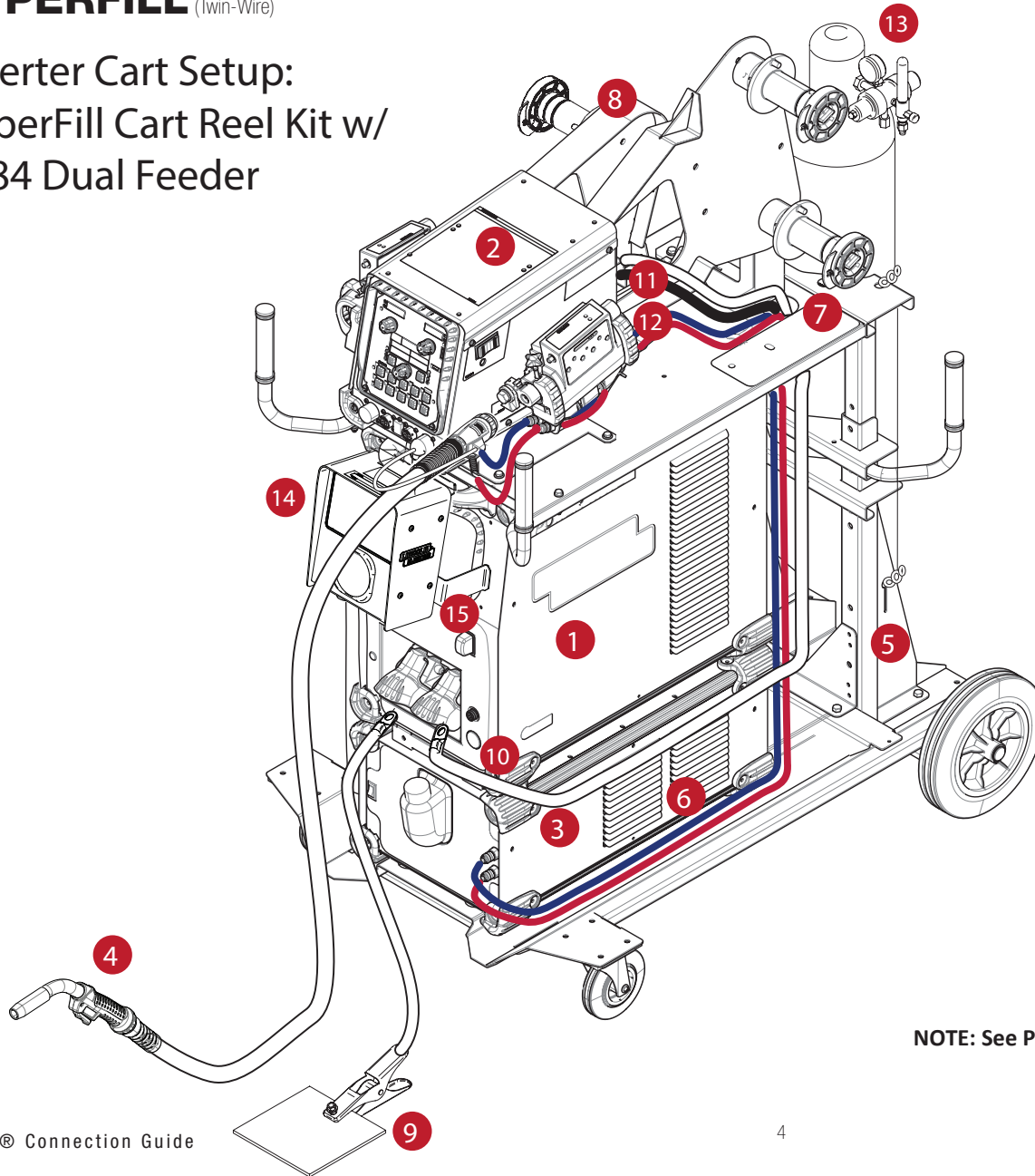

Item	Product Description	Part Number	Notes
1	Power Wave® S500	K2904-1	
2	Power Feed® 84 Bench Wire Feeder - U/I, No Reel, USB	K3328-1	Requires HyperFill Drive Roll Kit KP4388-X
	HyperFill™ Drive Roll Kit (.035" - .040" / 0.9 -1.0 mm)	KP4388-1	
3	Cool Arc® 55S or Cool Wave® 20S*	K3086-2 or K4713-1*	*Cool Wave® 20S required for S700
4	Magnum® PRO Water Cooled 500A Welding Gun	K4522-2-10-564	Requires HyperFill gun expendables
	HyperFill™ Diffuser	KP4481-1	
	HyperFill™ Contact Tip	KP4482-035 or KP4482-040	.035" (0.9mm) or .040" (1.0mm) Contact Tip
5	Inverter and Wire Feeder Cart	K3059-X	*K3059-4 for single bottle cart or K3059-5 for dual bottle cart
6	7 ft. Water Hose Kit	K4544-7	
7	HyperFill Cart Reel Kit	K4630-1	
8	Wire Reel Stand - Standard Duty	K3342-1	
9	Work Lead - Lug & GC500 Ground Clamp (3/0, 600A, 60%) 15 ft. (15.3 m)	K1842-XX* w/K910-2	*XX is application specific length
10	Weld Power Cable - Lug to Lug (3/0, 600A, 60%)	K1842-XX*	*XX is application specific length
11	Ext-Flex ArcLink®/Linc-Net® Control Cable	K4483-XX*	*XX is application specific length
12	4-Ball Roller Incoming Guide	K1551-2*	*Recommended
13	Harris® Flowmeter Regulator and Hose Kit	3100211	
14	Gateway Pendant (Includes 8ft ArcLink Cable)	K4997-1*	*Requires HyperFill Activation Card K4966-xx
15	Gateway Pendant Hanger Kit	K5294-1*	*Recommended

NOTE: See Page 11 for cooling capacity recommendations.

HYPERFILL[™] (Twin-Wire)

Inverter Cart Setup: Bulk Wire

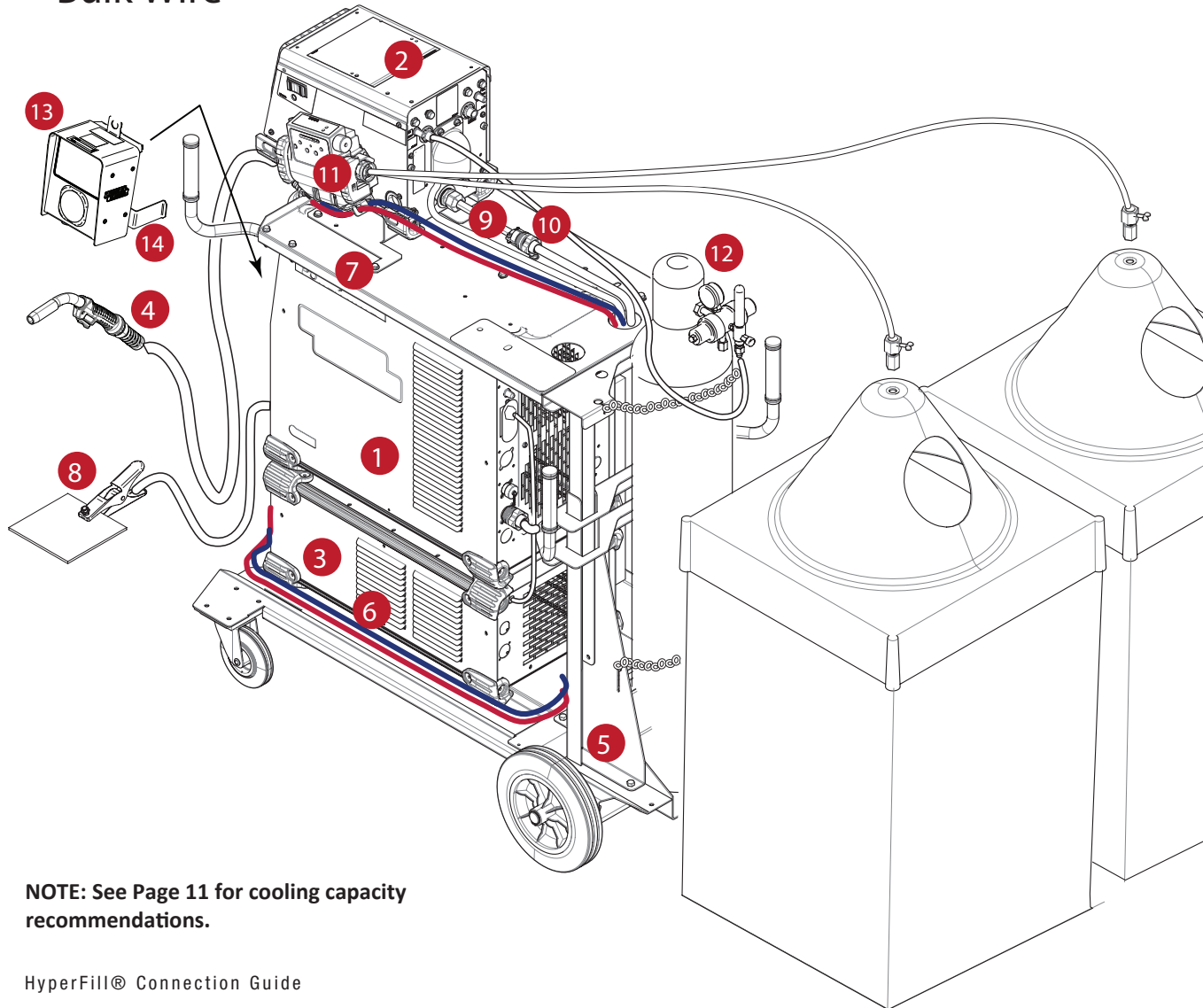

NOTE: See Page 11 for cooling capacity recommendations.

Item	Product Description	Part Number	Notes
1	Power Wave [®] S500	K2904-1	
2	Power Feed [®] 84 Dual Bench Wire Feeder - U/I, No Reel, USB	K3328-1	Requires HyperFill Drive Roll Kit KP4388-X
	HyperFill [™] Drive Roll Kit (.035" - .040" / 0.9 -1.0 mm)	KP4388-1	
3	Cool Arc [®] 55S or Cool Wave [®] 20S*	K3086-2 or K4713-1*	*Cool Wave [®] 20S required for S700
4	Magnum [®] PRO Water Cooled 500A Welding Gun	K4522-2-10-564	Requires HyperFill gun expendables
	HyperFill [™] Diffuser	KP4481-1	
	HyperFill [™] Contact Tip	KP4482-035 or KP4482-040	.035" (0.9mm) or .040" (1.0mm) Contact Tip
5	Inverter and Wire Feeder Cart	K3059-X	*K3059-4 for single bottle cart or K3059-5 for dual bottle cart
6	7 ft. Water Hose Kit	K4544-7	
7	Feeder Mounting Kit for Inverter Cart	K4068-1	
8	Work Lead - Lug & GC500 Ground Clamp (3/0, 600A, 60%) 15 ft. (15.3 m)	K1842-XX* w/K910-2	*XX is application specific length
9	Weld Power Cable - Lug to Lug (3/0, 600A, 60%)	K1842-XX*	*XX is application specific length
10	Ext-Flex ArcLink [®] /Linc-Net [®] Control Cable	K4483-XX*	*XX is application specific length
11	HyperFill Conduit Inlet Bushing	K4389-1	*Recommended
12	Harris [®] Flowmeter Regulator and Hose Kit	3100211	
13	Gateway Pendant (Includes 8ft ArcLink Cable)	K4997-1*	*Requires HyperFill Activation Card K4966-xx
14	Gateway Pendant Hanger Kit	K5294-1*	*Recommended

Product Description	Part Number
20 in. Accu-Trak Drum Payoff Kit	K884-5
23 in. Accu-Trak Drum Payoff Kit	K884-6
21 in. (500 lb) Accu-Pak Box Payoff Kit	K2175-1
23 in. (1000 lb) Accu-Pak Box Payoff Kit	K2175-2
Conduit w/(2) connectors, 10 ft	AD1329-449
Conduit w/(2) connectors, 15 ft	AD1329-451
Conduit w/(2) connectors, 20 ft	AD1329-452
Conduit w/(2) connectors, 25 ft	AD1329-453

HYPERFILL (Twin-Wire)

Undercarriage Setup: HyperFill Undercarriage Kit w/ PF84 Single Feeder

Item	Product Description	Part Number	Notes
1	Power Wave® S500 or S700	K2904-1 or K3279-1	
2	Power Feed® 84 Bench Wire Feeder - U/I, No Reel, USB	K3328-3	Requires HyperFill Drive Roll Kit KP4388-X
	HyperFill™ Drive Roll Kit (.035" - .040" / 0.9 - 1.0 mm)	KP4388-1	
	HyperFill™ Drive Roll Kit (.045" / 1.2 mm)	KP4388-2*	*.045" (1.2mm) for S700 Only
3	Cool Arc® 55S or Cool Wave® 20S*	K3086-2 or K4713-1*	*Cool Wave® 20S required for S700

Item	Product Description	Part Number	Notes
4	Magnum® PRO Water Cooled 500A Welding Gun	K4522-2-10-564	Requires HyperFill gun expendables
	HyperFill™ Diffuser	KP4481-1	
	HyperFill™ Contact Tip	KP4482-035 or KP4482-040	.035" (0.9mm) or .040" (1.0mm) Contact Tip
	HyperFill™ Contact Tip	KP4482-045*	*.045" (1.2mm) Contact Tip for S700 Only
5	Four Wheeled Wire Feeder Undercarriage	K163-1	
6	Hyperfill Bench Reel Kit	K4630-2	
7	Hyperfill Undercarriage Kit Work Lead - Lug & GC500 Ground Clamp (3/0, 600A, 60%)	K4630-3	
8	Weld Power Cable - Lug to Lug (3/0, 600A, 60%)	K1842-XX* w/K910-2	*XX is application specific length
9	Ext-Flex ArcLink®/Linc-Net® Control Cable	K1842-XX*	*XX is application specific length
10	4-Ball Roller Incoming Guide	K4483-XX*	*XX is application specific length
11	Gateway Pendant (Includes 8ft ArcLink Cable)	K1551-2*	*Recommended
12	Gateway Pendant Hanger Kit	K4997-1*	*Requires Hyperfill Activation Card K4966-xx
13	Gateway Pendant Hanger Kit	K5294-1*	*Recommended

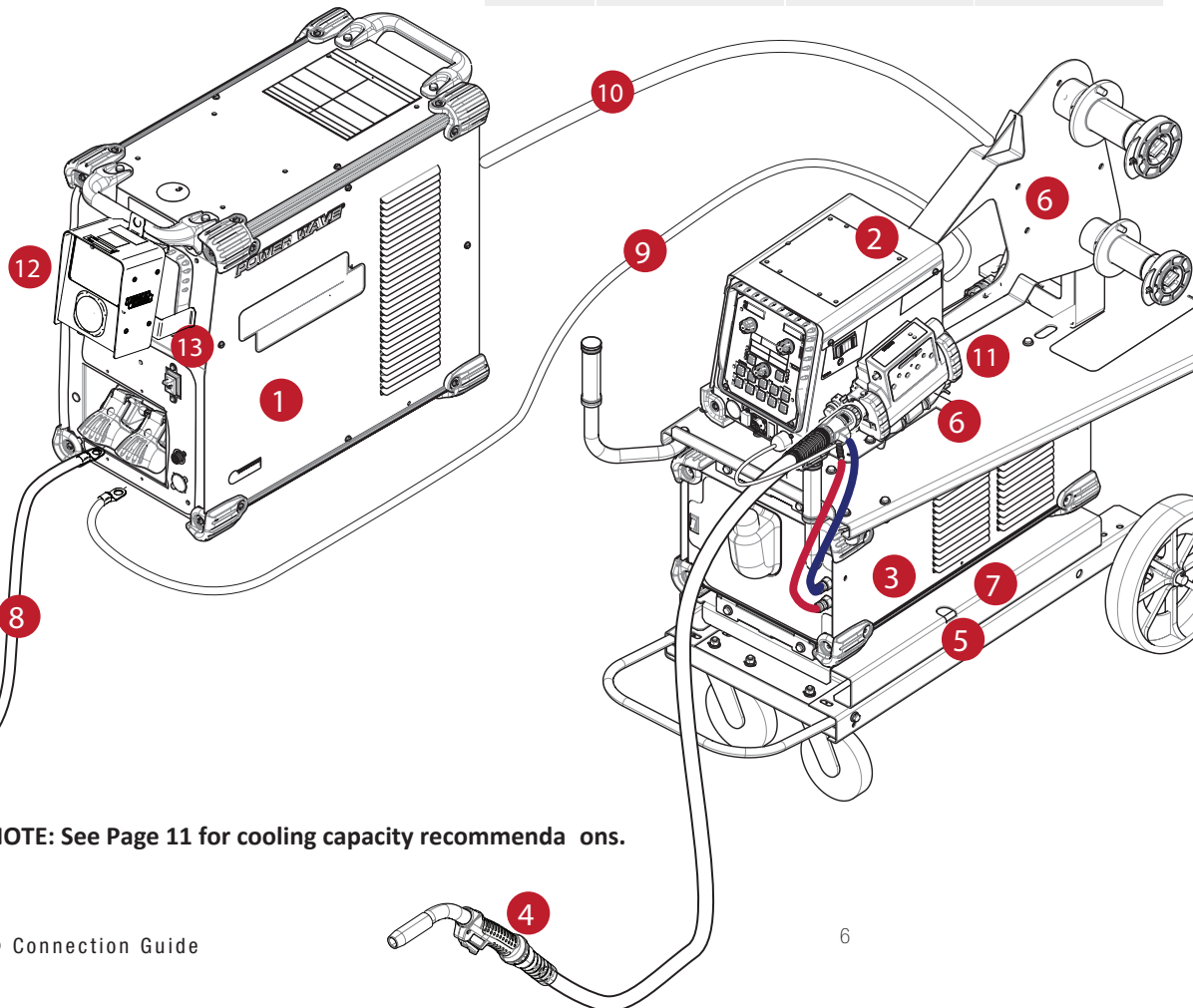

NOTE: See Page 11 for cooling capacity recommendations.

HYPERFILL™ (Twin-Wire)

Undercarriage Setup: HyperFill Undercarriage Kit w/ PF84 Dual Feeder

Item	Product Description	Part Number	Notes
1	Power Wave® S500 or S700	K2904-1 or K3279-1	
2	Power Feed® 84 Dual Bench Wire Feeder - U/I, No Reel, USB	K3330-3	Requires HyperFill Drive Roll Kit KP4388-X
	HyperFill™ Drive Roll Kit (.035" - .040" / 0.9 - 1.0 mm)	KP4388-1	
	HyperFill™ Drive Roll Kit (.045" / 1.2 mm)	KP4388-2*	*.045" (1.2mm) for S700 Only
3	Cool Arc® 55S or Cool Wave® 20S*	K3086-2 or K4713-1*	*Cool Wave® 20S required for S700

Item	Product Description	Part Number	Notes
4	Magnum® PRO Water Cooled 500A Welding Gun	K4522-1-10-564	Requires HyperFill gun expendables
	HyperFill™ Diffuser	KP4481-1	
	HyperFill™ Contact Tip	KP4482-035 or KP4482-040	.035" (0.9mm) or .040" (1.0mm) Contact Tip
	HyperFill™ Contact Tip	KP4482-045*	*.045" (1.2mm) Contact Tip for S700 Only
5	Four Wheeled Wire Feeder Undercarriage	K163-1	
6	Hyperfill Bench Reel Kit	K4630-2	
7	Hyperfill Undercarriage Kit	K4630-3	
8	Work Lead - Lug & GC500 Ground Clamp (3/0, 600A, 60%)	K1842-XX* w/K910-2	*XX is application specific length
9	Weld Power Cable - Lug to Lug (3/0, 600A, 60%)	K1842-XX*	*XX is application specific length
10	Ext-Flex ArcLink®/Linc-Net® Control Cable	K4483-XX*	*XX is application specific length
11	4-Ball Roller Incoming Guide	K1551-2*	*Recommended
12	Wire Reel Stand - Standard Duty	K3342-1	
13	Gateway Pendant (Includes 8ft ArcLink Cable)	K4997-1*	*Requires Hyperfill Activation Card K4966-xx
14	Gateway Pendant Hanger Kit	K5294-1*	*Recommended

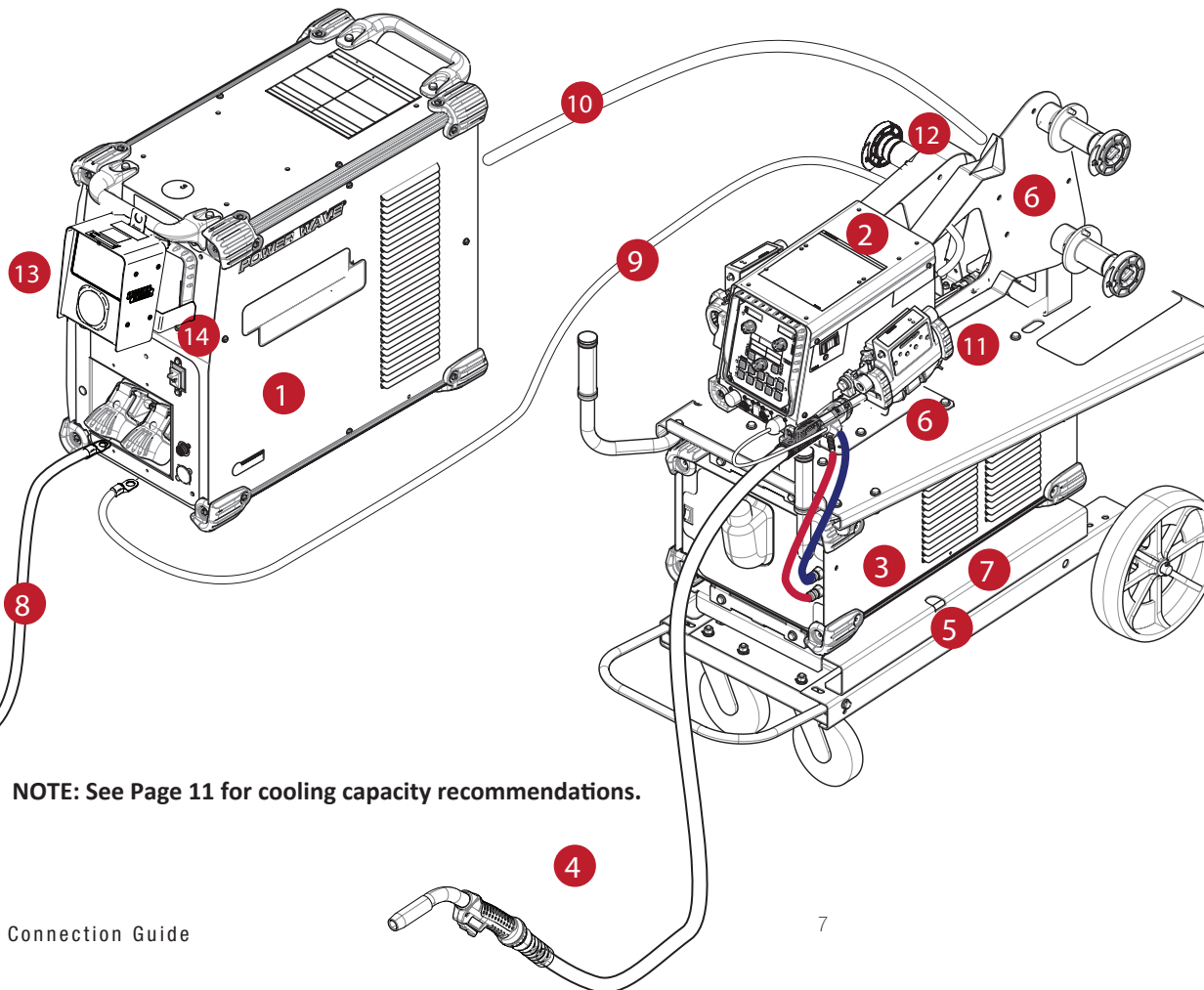

NOTE: See Page 11 for cooling capacity recommendations.

HYPERFILL (Twin-Wire)

Benchtop Setup: HyperFill Bench Reel Kit w/ PF84 Single Feeder

Item	Product Description	Part Number	Notes
1	Power Wave® S500 or S700	K2904-1 or K3279-1	
2	Power Feed® 84 Bench Wire Feeder - U/I, No Reel, USB	K3328-3	Requires HyperFill Drive Roll Kit KP4388-X
	HyperFill™ Drive Roll Kit (.035" - .040" / 0.9 - 1.0 mm)	KP4388-1	
	HyperFill™ Drive Roll Kit (.045" / 1.2 mm)	KP4388-2*	*.045" (1.2mm) for S700 Only
3	Cool Arc® 555 or Cool Wave® 20S*	K3086-2 or K4713-1*	*Cool Wave® 20S required for S700

Item	Product Description	Part Number	Notes
4	Magnum® PRO Water Cooled 500A Welding Gun	K4522-2-10-564	Requires HyperFill gun expendables
	HyperFill™ Diffuser	KP4481-1	
	HyperFill™ Contact Tip	KP4482-035 or KP4482-040	.035" (0.9mm) or .040" (1.0mm) Contact Tip
	HyperFill™ Contact Tip	KP4482-045*	*.045" (1.2mm) Contact Tip for S700 Only
5	7 ft. or 25 ft. Water Hose Kit	K4544-7 or K4544-25	
6	Hyperfill Bench Reel Kit	K4630-2	
7	Work Lead - Lug & GC500 Ground Clamp (3/0, 600A, 60%)	K1842-XX* w/K910-2	*XX is application specific length
8	Weld Power Cable- Lug to Lug (3/0, 600A, 60%)	K1842-XX*	*XX is application specific length
9	Ext-Flex ArcLink®/Linc-Net® Control Cable	K4483-XX*	*XX is application specific length
10	4-Ball Roller Incoming Guide	K1551-2*	*Recommended
11	Harris® Flowmeter Regulator and Hose Kit	3100211	
12	Gateway Pendant (Includes 8ft ArkLink Cable)	K4997-1*	*Requires Hyperfill Activation Card K4966-xx
13	Gateway Pendant Hanger Kit	K5294-1*	*Recommended

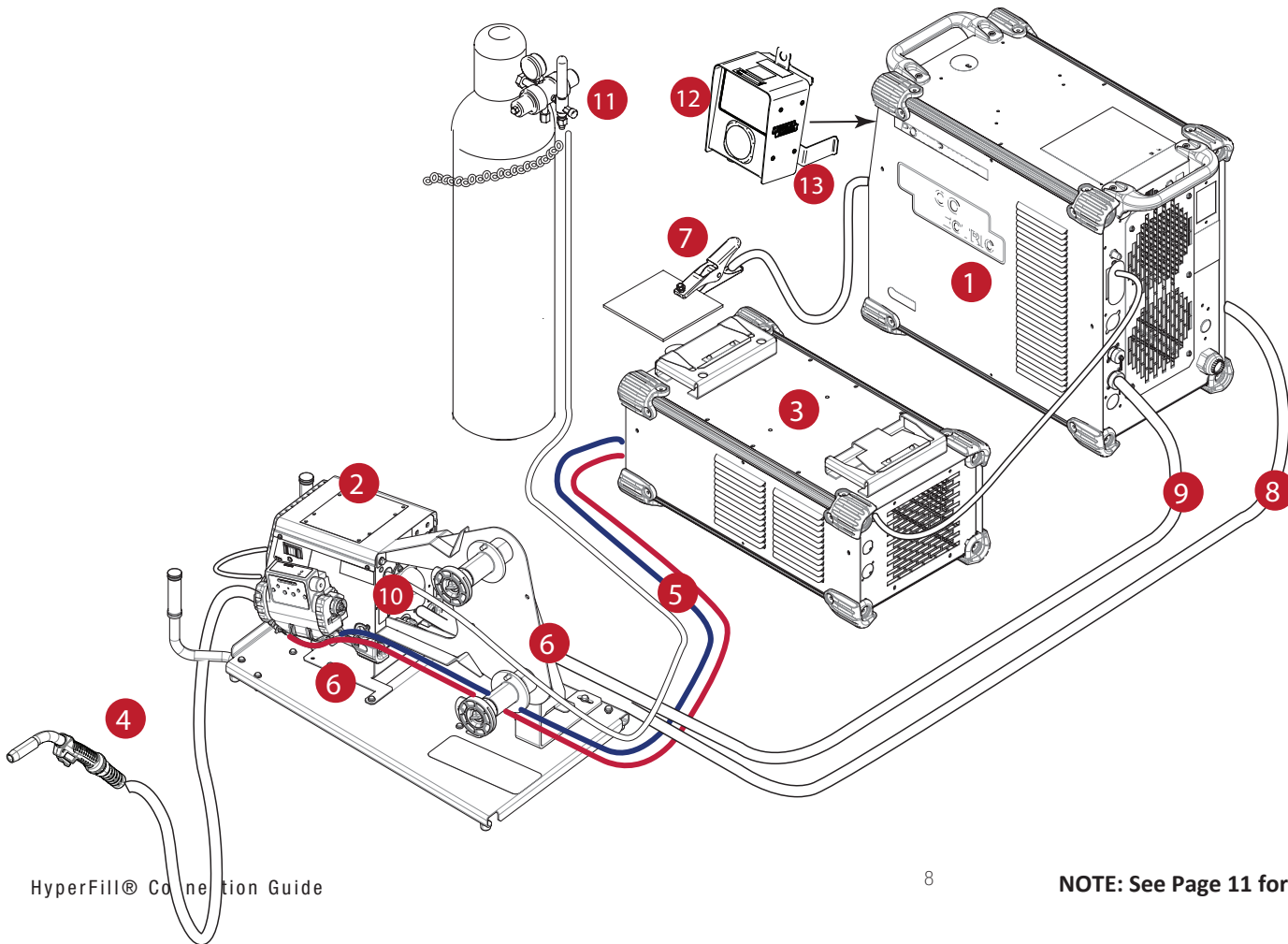

HYPERFILL (Twin-Wire)

Benchtop Setup: HyperFill Bench Reel w/ PF84 Dual Feeder

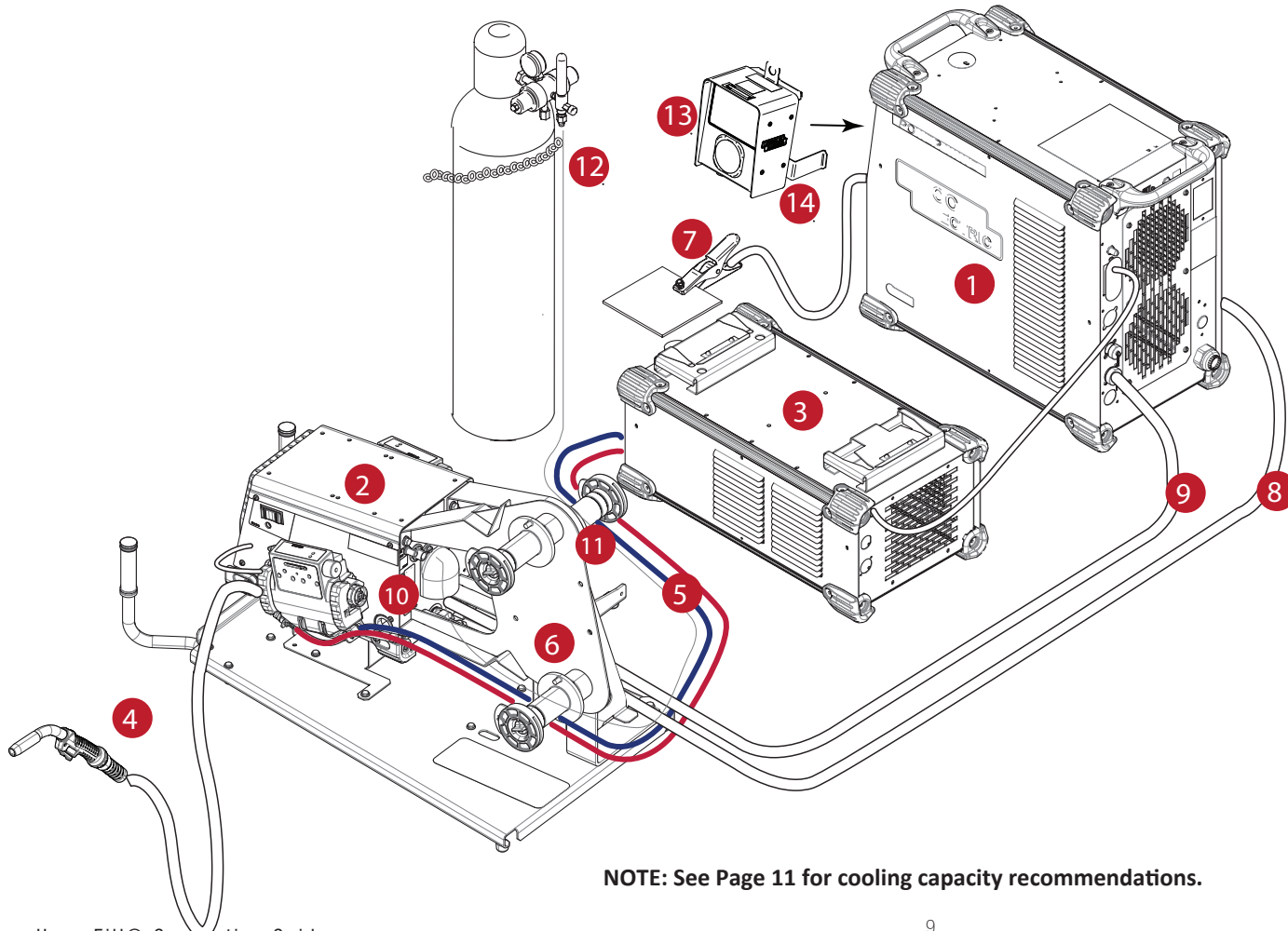

NOTE: See Page 11 for cooling capacity recommendations.

Item	Product Description	Part Number	Notes
1	Power Wave® S500 <u>or</u> S700	K2904-1 <u>or</u> K3279-1	
2	Power Feed® 84 Dual Bench Wire Feeder - U/I, No Reel, USB	K3330-3	Requires HyperFill Drive Roll Kit KP4388-X
	HyperFill™ Drive Roll Kit (.035" - .040" / 0.9-1.0 mm)	KP4388-1	
	HyperFill™ Drive Roll Kit (.045" / 1.2 mm)	KP4388-2*	*.045" (1.2mm) for S700 Only
3	Cool Arc® 55S <u>or</u> Cool Wave® 20S*	K3086-2 <u>or</u> K4713-1*	*Cool Wave® 20S required for S700

Item	Product Description	Part Number	Notes
4	Magnum® PRO Water Cooled 500A Welding Gun	K4522-2-10-564	Requires HyperFill gun expendables
	HyperFill™ Diffuser	KP4481-1	
	HyperFill™ Contact Tip	KP4482-035 or KP4482-040	.035" (0.9mm) or .040" (1.0mm) Contact Tip
	HyperFill™ Contact Tip	KP4482-045*	*.045" (1.2mm) Contact Tip for S700 Only
5	7 ft. or 25 ft. Water Hose Kit	K4544-7 or K4544-25	
6	Hyperfill Bench Reel Kit	K4630 2	
7	Work Lead - Lug & GC500 Ground Clamp (3/0, 600A, 60%)	K1842-XX* w/K910-2	*XX is application specific length
8	Weld Power Cable - Lug to Lug (3/0, 600A, 60%)	K1842-XX*	*XX is application specific length
9	Ext-Flex ArcLink®/Linc-Net® Control Cable	K4483-XX*	*XX is application specific length
10	4-Ball Roller Incoming Guide	K1551-2*	*Recommended
11	Wire Reel Stand - Standard Duty	K3342-1	
12	Harris® Flowmeter Regulator and Hose Kit	3100211	
13	Gateway Pendant (Includes 8ft ArcLink Cable)	K4997-1*	*Requires Hyperfill Activation Card K4966-xx
14	Gateway Pendant Hanger Kit	K5294-1*	*Recommended

Item	Product Description	Part Number	Notes
1	PipeFab® Ready-Pak	K3734-1	
2	PipeFab® Cooler	K3737-1	
3	M-F Water Hose Kit (7 ft.)	K4544-7	
4	PipeFab® HyperFill Reel Stand	K4793-1	

HYPERFILL (Twin-Wire)

Benchtop Setup: PipeFab® Ready-Pak w/ PipeFab Cooler & HyperFill Reel Stand

Item	Product Description	Part Number	Notes
5	Magnum® PRO Water Cooled 500A (15 ft.)	K4522-2-10-564	
	HyperFill™ Diffuser	KP4481-1	
	HyperFill™ Contact Tip	KP4482-0XX*	*.035" (0.9mm) or .040" (1.0mm) Contact Tip
6	HyperFill™ Drive Roll Kit (.035" - .040" / 0.9 - 1.0mm)	KP4388-1	
7	4-Ball Roller Incoming Guide	K1551-2	*Recommended
8	Harris® Flowmeter Regulator and Hose Kit	3100211	
9	Gateway Pendant (Includes 8ft ArcLink Cable)	K4997-1*	*Requires Hyperfill Activation Card K4966-xx
10	Gateway Pendant Hanger Kit	K5294-1*	*Recommended

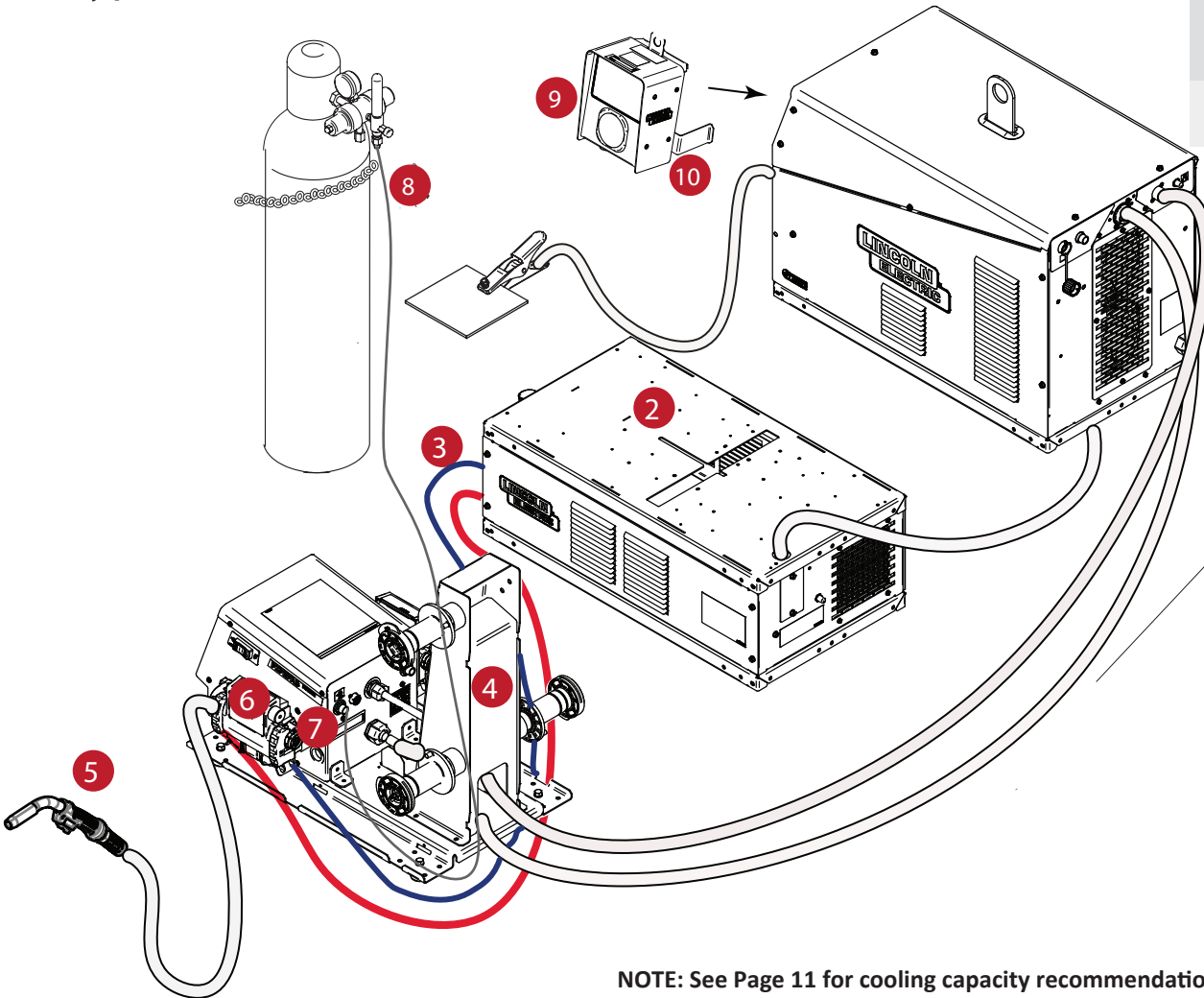

NOTE: See Page 11 for cooling capacity recommendations.

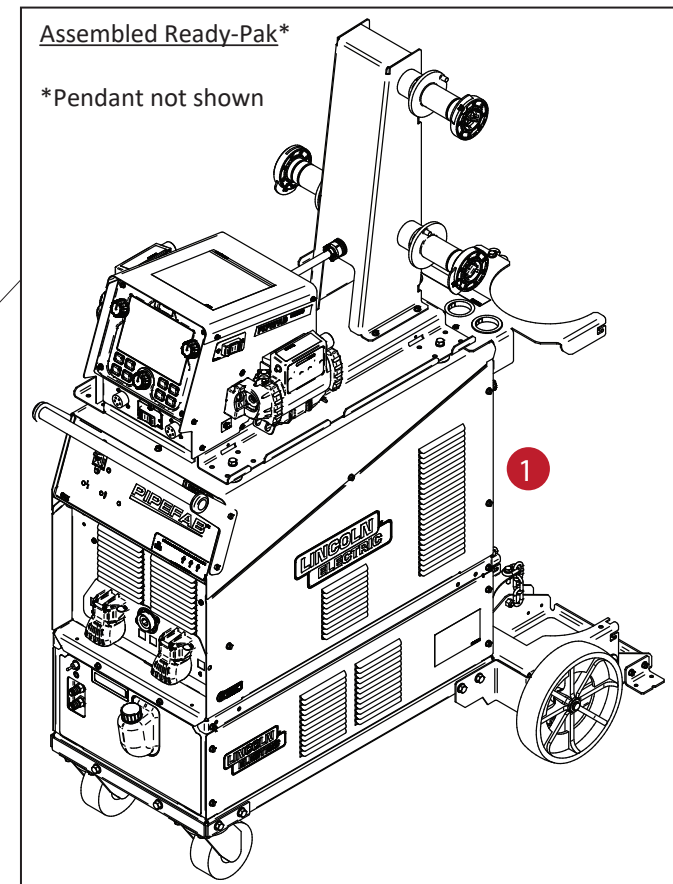

HYPERFILL (Twin-Wire)

Gun Expendables

Item	Product Description	Part Number	Notes
1	HyperFill™ Diffuser	KP4481-1	
2	HyperFill™ Contact Tip - 0.035 (0.9mm)	KP4482-035	
	HyperFill™ Contact Tip - 0.040 (1.0mm)	KP4482-040	
	HyperFill™ Contact Tip - 0.045 (1.2mm)	KP4482-045	
3	Magnum® Pro 15 ft. Gun Liner 5/64" (.035-.040" HyperFill)	KP44-564-15	
	Magnum® Pro 15 ft. Gun Liner 3/32" (.045" HyperFill)	KP44-332-15	
4	Magnum® Pro WC Nozzle 1/8" Recess 3/4" ID	KP4523-1-75R	

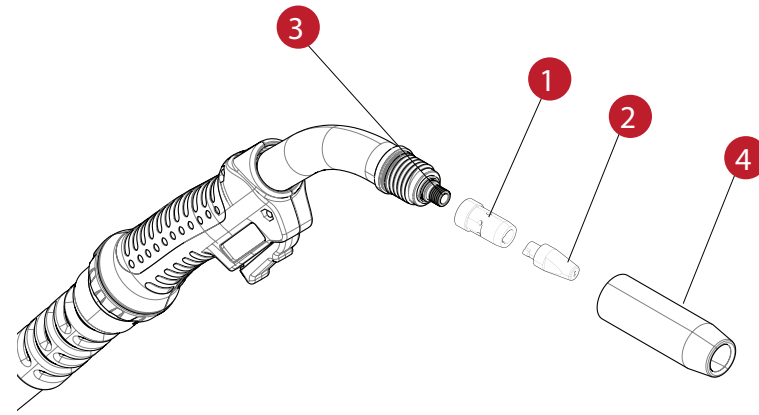

Wire Feeder Expendables

Item	Product Description	Part Number	Notes
5	HyperFill™ Drive Roll Kit (.035 - .040 / 0.9 - 1.0mm)	KP4388-1	
	HyperFill™ Drive Roll Kit (.045 / 1.2mm)	KP4388-2	
	HyperFill™ Metal Cored Drive Roll Kit (.045 / 1.2mm)	KP4388-3	

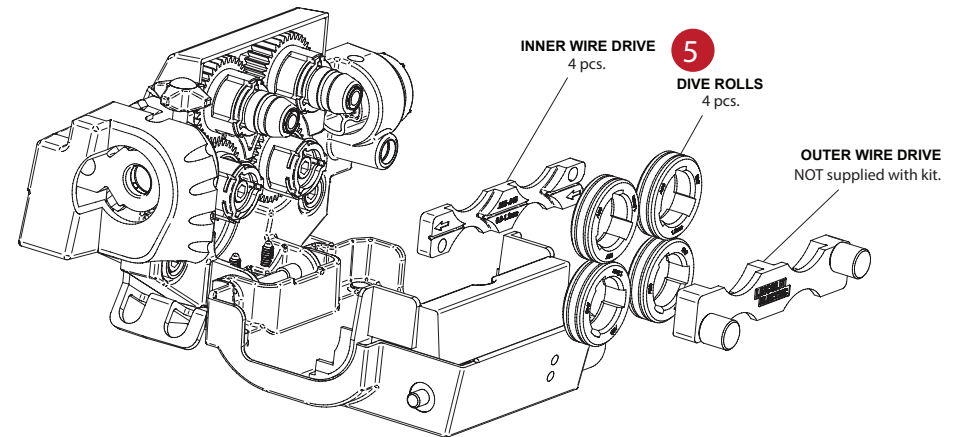

Note: In Magnum® PRO Water Cooled Gun applications exceeding 425A @ 70% duty cycle, the Cool Wave™ 20S should be used. For applications with hose lengths longer than 25ft, 3/8" water hoses should be used.

HyperFill Activation Cards (Not Pictured)

Item	Product Description	Part Number	Notes
	HyperFill™ Steel Activation Card (1000lb)	K4996-1000	
	HyperFill™ Steel Activation Card (500lb)	K4996-500	
	HyperFill™ Steel Activation Card (88lb)	K4996-88	

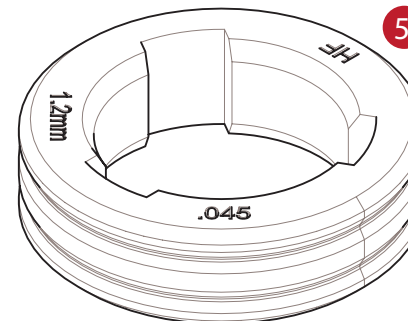

CUSTOMER ASSISTANCE POLICY

HyperFill® Waveform Activation Capability with Power Wave® and PIPEFAB™ Systems

Your purchase of a Lincoln Power Wave Welding System comes with (i) a license to use Lincoln Electric standard Power Wave waveforms, and (ii) HyperFill waveform capability, which requires a separate license. Without the separate license, the HyperFill waveform is not available for use on these machines, and only the standard Power Wave waveforms are usable.

The business of The Lincoln Electric Company is manufacturing and selling high quality welding equipment, consumables, and cutting equipment. Our challenge is to meet the needs of our customers and to exceed their expectations. On occasion, purchasers may ask Lincoln Electric for advice or information about their use of our products. We respond to our customers based on the best information in our possession at that time. Lincoln Electric is not in a position to warrant or guarantee such advice, and assumes no liability, with respect to such information or advice. We expressly disclaim any warranty of any kind, including any warranty of fitness for any customer's particular purpose, with respect to such information or advice. As a matter of practical consideration, we also cannot assume any responsibility for updating or correcting any such information or advice once it has been given, nor does the provision of information or advice create, expand or alter any warranty with respect to the sale of our products.

Lincoln Electric is a responsive manufacturer, but the selection and use of specific products sold by Lincoln Electric is solely within the control of, and remains the sole responsibility of the customer. Many variables beyond the control of Lincoln Electric affect the results obtained in applying these types of fabrication methods and service requirements.

Subject to Change – This information is accurate to the best of our knowledge at the time of printing. Please refer to www.lincolnelectric.com for any updated information.



THE LINCOLN ELECTRIC COMPANY

22801 St. Clair Avenue • Cleveland, OH • 44117-1199 • U.S.A.

Phone: +1.216.481.8100 • www.lincolnelectric.com