

RANGER 250 WIRING DIAGRAM M20443 REV: D

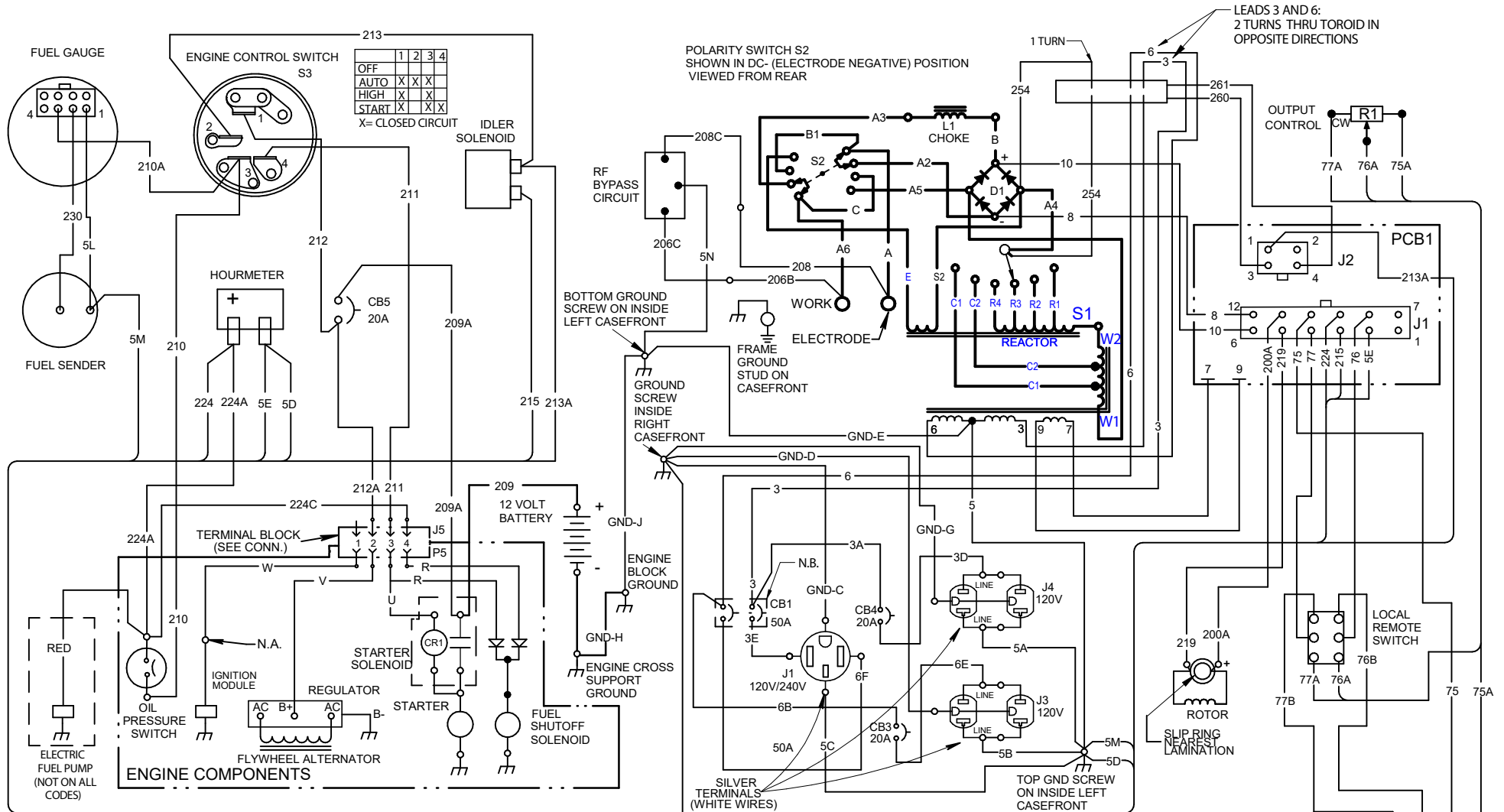

N.A. GROUNDING THIS TERMINAL STOPS THE ENGINE.
 N.B. ON MACHINE CODES BELOW 11269, CB1 WAS TWO SINGLE POLE BREAKERS IDENTIFIED AS CB1 & CB2.

LEAD COLOR CODE:
 B = BLACK OR GRAY U = BLUE
 R = RED OR PINK V = VIOLET
 W = WHITE

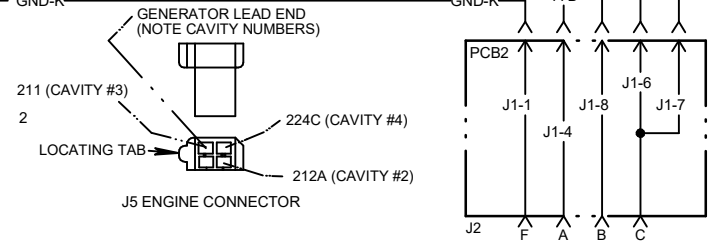
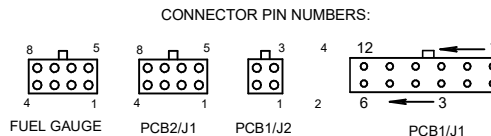

ALL CASE FRONT COMPONENTS SHOWN VIEWED FROM REAR.



CLEVELAND, OHIO U.S.A.