



**NOTE:** This manual will cover most of the troubleshooting and repair procedures for the code numbers listed. Some variances may exist when troubleshooting/repairing later code numbers.

## **IDEALARC® DC-600**

For use with machines having Code Numbers:

**8213; 8222; 8223; 8224; 8225; 8249; 8250; 8251; 8252; 8253; 8262; 8268; 8273; 8274; 8288; 8289; 8295; 8298; 8301; 8304; 8315; 8318; 8324; 8353; 8380; 8549; 8555; 8584; 8692; 8693; 8694; 8695; 8702; 8722; 8728; 8738; 8764; 8782; 8789; 8825; 8902; 8904; 8906; 8907; 8911; 8934; 8954; 8988; 9080; 9093; 9130; 9158; 9170; 9171; 9353; 9354; 9355; 9356; 9357; 9358; 9359; 9360; 9361; 9362; 9363; 9364; 9384; 9385; 9463; 9464; 9465; 9470; 9483; 9607; 9620; 9621; 9716; 9717; 9773; 9774; 9775; 9776; 9777; 9778; 9779; 9780; 9781; 9782; 9793; 9832; 9910; 10159; 10282; 10283; 10334; 10335; 10407; 10408**

# **SERVICE MANUAL**

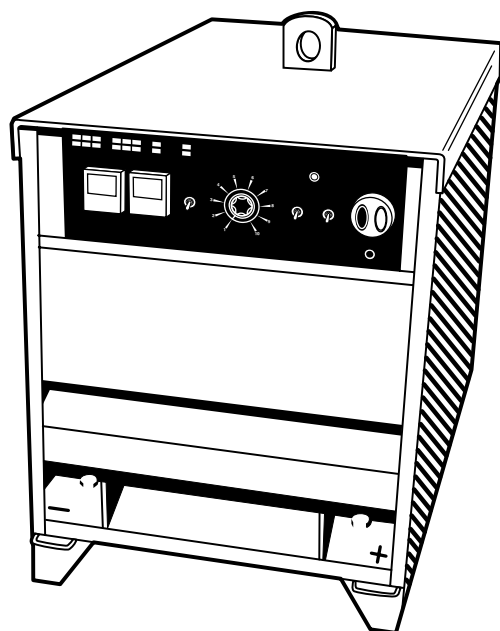

## ⚠ WARNING

### ⚠ CALIFORNIA PROPOSITION 65 WARNINGS ⚠

Diesel engine exhaust and some of its constituents are known to the State of California to cause cancer, birth defects, and other reproductive harm.

The Above For Diesel Engines

The engine exhaust from this product contains chemicals known to the State of California to cause cancer, birth defects, or other reproductive harm.

The Above For Gasoline Engines

**ARC WELDING can be hazardous. PROTECT YOURSELF AND OTHERS FROM POSSIBLE SERIOUS INJURY OR DEATH. KEEP CHILDREN AWAY. PACEMAKER WEARERS SHOULD CONSULT WITH THEIR DOCTOR BEFORE OPERATING.**

Read and understand the following safety highlights. For additional safety information, it is strongly recommended that you purchase a copy of "Safety in Welding & Cutting - ANSI Standard Z49.1" from the American Welding Society, P.O. Box 351040, Miami, Florida 33135 or CSA Standard W117.2-1974. A Free copy of "Arc Welding Safety" booklet E205 is available from the Lincoln Electric Company, 22801 St. Clair Avenue, Cleveland, Ohio 44117-1199.

**BE SURE THAT ALL INSTALLATION, OPERATION, MAINTENANCE AND REPAIR PROCEDURES ARE PERFORMED ONLY BY QUALIFIED INDIVIDUALS.**



### FOR ENGINE powered equipment.

1.a. Turn the engine off before troubleshooting and maintenance work unless the maintenance work requires it to be running.



1.b. Operate engines in open, well-ventilated areas or vent the engine exhaust fumes outdoors.



1.c. Do not add the fuel near an open flame welding arc or when the engine is running. Stop the engine and allow it to cool before refueling to prevent spilled fuel from vaporizing on contact with hot engine parts and igniting. Do not spill fuel when filling tank. If fuel is spilled, wipe it up and do not start engine until fumes have been eliminated.

1.d. Keep all equipment safety guards, covers and devices in position and in good repair. Keep hands, hair, clothing and tools away from V-belts, gears, fans and all other moving parts when starting, operating or repairing equipment.

1.e. In some cases it may be necessary to remove safety guards to perform required maintenance. Remove guards only when necessary and replace them when the maintenance requiring their removal is complete. Always use the greatest care when working near moving parts.



1.f. Do not put your hands near the engine fan. Do not attempt to override the governor or idler by pushing on the throttle control rods while the engine is running.

1.g. To prevent accidentally starting gasoline engines while turning the engine or welding generator during maintenance work, disconnect the spark plug wires, distributor cap or magneto wire as appropriate.



1.h. To avoid scalding, do not remove the radiator pressure cap when the engine is hot.



### ELECTRIC AND MAGNETIC FIELDS may be dangerous

2.a. Electric current flowing through any conductor causes localized Electric and Magnetic Fields (EMF). Welding current creates EMF fields around welding cables and welding machines

2.b. EMF fields may interfere with some pacemakers, and welders having a pacemaker should consult their physician before welding.

2.c. Exposure to EMF fields in welding may have other health effects which are now not known.

2.d. All welders should use the following procedures in order to minimize exposure to EMF fields from the welding circuit:

2.d.1. Route the electrode and work cables together - Secure them with tape when possible.

2.d.2. Never coil the electrode lead around your body.

2.d.3. Do not place your body between the electrode and work cables. If the electrode cable is on your right side, the work cable should also be on your right side.

2.d.4. Connect the work cable to the workpiece as close as possible to the area being welded.

2.d.5. Do not work next to welding power source.



### ELECTRIC SHOCK can kill.

3.a. The electrode and work (or ground) circuits are electrically “hot” when the welder is on. Do not touch these “hot” parts with your bare skin or wet clothing. Wear dry, hole-free gloves to insulate hands.

3.b. Insulate yourself from work and ground using dry insulation. Make certain the insulation is large enough to cover your full area of physical contact with work and ground.

**In addition to the normal safety precautions, if welding must be performed under electrically hazardous conditions (in damp locations or while wearing wet clothing; on metal structures such as floors, gratings or scaffolds; when in cramped positions such as sitting, kneeling or lying, if there is a high risk of unavoidable or accidental contact with the workpiece or ground) use the following equipment:**

- Semiautomatic DC Constant Voltage (Wire) Welder.
- DC Manual (Stick) Welder.
- AC Welder with Reduced Voltage Control.

3.c. In semiautomatic or automatic wire welding, the electrode, electrode reel, welding head, nozzle or semiautomatic welding gun are also electrically “hot”.

3.d. Always be sure the work cable makes a good electrical connection with the metal being welded. The connection should be as close as possible to the area being welded.

3.e. Ground the work or metal to be welded to a good electrical (earth) ground.

3.f. Maintain the electrode holder, work clamp, welding cable and welding machine in good, safe operating condition. Replace damaged insulation.

3.g. Never dip the electrode in water for cooling.

3.h. Never simultaneously touch electrically “hot” parts of electrode holders connected to two welders because voltage between the two can be the total of the open circuit voltage of both welders.

3.i. When working above floor level, use a safety belt to protect yourself from a fall should you get a shock.

3.j. Also see Items 6.c. and 8.



### ARC RAYS can burn.

4.a. Use a shield with the proper filter and cover plates to protect your eyes from sparks and the rays of the arc when welding or observing open arc welding. Headshield and filter lens should conform to ANSI Z87.1 standards.

4.b. Use suitable clothing made from durable flame-resistant material to protect your skin and that of your helpers from the arc rays.

4.c. Protect other nearby personnel with suitable, non-flammable screening and/or warn them not to watch the arc nor expose themselves to the arc rays or to hot spatter or metal.



### FUMES AND GASES can be dangerous.

5.a. Welding may produce fumes and gases hazardous to health. Avoid breathing these fumes and gases. When welding, keep your head out of the fume. Use enough ventilation and/or exhaust at the arc to keep fumes and gases away from the breathing zone. **When welding with electrodes which require special ventilation such as stainless or hard facing (see instructions on container or MSDS) or on lead or cadmium plated steel and other metals or coatings which produce highly toxic fumes, keep exposure as low as possible and within applicable OSHA PEL and ACGIH TLV limits using local exhaust or mechanical ventilation. In confined spaces or in some circumstances, outdoors, a respirator may be required. Additional precautions are also required when welding on galvanized steel.**

5.b. The operation of welding fume control equipment is affected by various factors including proper use and positioning of the equipment, maintenance of the equipment and the specific welding procedure and application involved. Worker exposure level should be checked upon installation and periodically thereafter to be certain it is within applicable OSHA PEL and ACGIH TLV limits.

5.c. Do not weld in locations near chlorinated hydrocarbon vapors coming from degreasing, cleaning or spraying operations. The heat and rays of the arc can react with solvent vapors to form phosgene, a highly toxic gas, and other irritating products.

5.d. Shielding gases used for arc welding can displace air and cause injury or death. Always use enough ventilation, especially in confined areas, to insure breathing air is safe.

5.e. Read and understand the manufacturer’s instructions for this equipment and the consumables to be used, including the material safety data sheet (MSDS) and follow your employer’s safety practices. MSDS forms are available from your welding distributor or from the manufacturer.

5.f. Also see item 1.b.

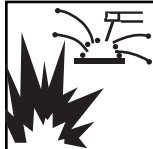

## WELDING and CUTTING SPARKS can cause fire or explosion.

6.a. Remove fire hazards from the welding area. If this is not possible, cover them to prevent the welding sparks from starting a fire. Remember that welding sparks and hot materials from welding can easily go through small cracks and openings to adjacent areas. Avoid welding near hydraulic lines. Have a fire extinguisher readily available.

- 6.b. Where compressed gases are to be used at the job site, special precautions should be used to prevent hazardous situations. Refer to "Safety in Welding and Cutting" (ANSI Standard Z49.1) and the operating information for the equipment being used.
- 6.c. When not welding, make certain no part of the electrode circuit is touching the work or ground. Accidental contact can cause overheating and create a fire hazard.
- 6.d. Do not heat, cut or weld tanks, drums or containers until the proper steps have been taken to insure that such procedures will not cause flammable or toxic vapors from substances inside. They can cause an explosion even though they have been "cleaned". For information, purchase "Recommended Safe Practices for the Preparation for Welding and Cutting of Containers and Piping That Have Held Hazardous Substances", AWS F4.1 from the American Welding Society (see address above).
- 6.e. Vent hollow castings or containers before heating, cutting or welding. They may explode.
- 6.f. Sparks and spatter are thrown from the welding arc. Wear oil free protective garments such as leather gloves, heavy shirt, cuffless trousers, high shoes and a cap over your hair. Wear ear plugs when welding out of position or in confined places. Always wear safety glasses with side shields when in a welding area.
- 6.g. Connect the work cable to the work as close to the welding area as practical. Work cables connected to the building framework or other locations away from the welding area increase the possibility of the welding current passing through lifting chains, crane cables or other alternate circuits. This can create fire hazards or overheat lifting chains or cables until they fail.
- 6.h. Also see item 1.c.
- 6.i. Read and follow NFPA 51B "Standard for Fire Prevention During Welding, Cutting and Other Hot Work", available from NFPA, 1 Batterymarch Park, PO box 9101, Quincy, Ma 022690-9101.
- 6.j. Do not use a welding power source for pipe thawing.



## CYLINDER may explode if damaged.

- 7.a. Use only compressed gas cylinders containing the correct shielding gas for the process used and properly operating regulators designed for the gas and pressure used. All hoses, fittings, etc. should be suitable for the application and maintained in good condition.
- 7.b. Always keep cylinders in an upright position securely chained to an undercarriage or fixed support.
- 7.c. Cylinders should be located:
  - Away from areas where they may be struck or subjected to physical damage.
  - A safe distance from arc welding or cutting operations and any other source of heat, sparks, or flame.
- 7.d. Never allow the electrode, electrode holder or any other electrically "hot" parts to touch a cylinder.
- 7.e. Keep your head and face away from the cylinder valve outlet when opening the cylinder valve.
- 7.f. Valve protection caps should always be in place and hand tight except when the cylinder is in use or connected for use.
- 7.g. Read and follow the instructions on compressed gas cylinders, associated equipment, and CGA publication P-1, "Precautions for Safe Handling of Compressed Gases in Cylinders," available from the Compressed Gas Association 1235 Jefferson Davis Highway, Arlington, VA 22202.



## FOR ELECTRICALLY powered equipment.

- 8.a. Turn off input power using the disconnect switch at the fuse box before working on the equipment.
- 8.b. Install equipment in accordance with the U.S. National Electrical Code, all local codes and the manufacturer's recommendations.
- 8.c. Ground the equipment in accordance with the U.S. National Electrical Code and the manufacturer's recommendations.

Refer to <http://www.lincolnelectric.com/safety> for additional safety information.

## PRÉCAUTIONS DE SÛRETÉ

Pour votre propre protection lire et observer toutes les instructions et les précautions de sûreté spécifiques qui paraissent dans ce manuel aussi bien que les précautions de sûreté générales suivantes:

### Sûreté Pour Soudage A L'Arc

1. Protégez-vous contre la secousse électrique:
  - a. Les circuits à l'électrode et à la pièce sont sous tension quand la machine à souder est en marche. Eviter toujours tout contact entre les parties sous tension et la peau nue ou les vêtements mouillés. Porter des gants secs et sans trous pour isoler les mains.
  - b. Faire très attention de bien s'isoler de la masse quand on soude dans des endroits humides, ou sur un plancher métallique ou des grilles métalliques, principalement dans les positions assis ou couché pour lesquelles une grande partie du corps peut être en contact avec la masse.
  - c. Maintenir le porte-électrode, la pince de masse, le câble de soudage et la machine à souder en bon et sûr état de fonctionnement.
  - d. Ne jamais plonger le porte-électrode dans l'eau pour le refroidir.
  - e. Ne jamais toucher simultanément les parties sous tension des porte-électrodes connectés à deux machines à souder parce que la tension entre les deux pinces peut être le total de la tension à vide des deux machines.
  - f. Si on utilise la machine à souder comme une source de courant pour soudage semi-automatique, ces précautions pour le porte-électrode s'appliquent aussi au pistolet de soudage.
2. Dans le cas de travail au dessus du niveau du sol, se protéger contre les chutes dans le cas où on reçoit un choc. Ne jamais enrouler le câble-électrode autour de n'importe quelle partie du corps.
3. Un coup d'arc peut être plus sévère qu'un coup de soliel, donc:
  - a. Utiliser un bon masque avec un verre filtrant approprié ainsi qu'un verre blanc afin de se protéger les yeux du rayonnement de l'arc et des projections quand on soude ou quand on regarde l'arc.
  - b. Porter des vêtements convenables afin de protéger la peau de soudeur et des aides contre le rayonnement de l'arc.
  - c. Protéger l'autre personnel travaillant à proximité au soudage à l'aide d'écrans appropriés et non-inflammables.
4. Des gouttes de laitier en fusion sont émises de l'arc de soudage. Se protéger avec des vêtements de protection libres de l'huile, tels que les gants en cuir, chemise épaisse, pantalons sans revers, et chaussures montantes.
5. Toujours porter des lunettes de sécurité dans la zone de soudage. Utiliser des lunettes avec écrans latéraux dans les zones où l'on pique le laitier.

6. Eloigner les matériaux inflammables ou les recouvrir afin de prévenir tout risque d'incendie dû aux étincelles.
7. Quand on ne soude pas, poser la pince à un endroit isolé de la masse. Un court-circuit accidentel peut provoquer un échauffement et un risque d'incendie.
8. S'assurer que la masse est connectée le plus près possible de la zone de travail qu'il est pratique de le faire. Si on place la masse sur la charpente de la construction ou d'autres endroits éloignés de la zone de travail, on augmente le risque de voir passer le courant de soudage par les chaînes de levage, câbles de grue, ou autres circuits. Cela peut provoquer des risques d'incendie ou d'échauffement des chaînes et des câbles jusqu'à ce qu'ils se rompent.
9. Assurer une ventilation suffisante dans la zone de soudage. Ceci est particulièrement important pour le soudage de tôles galvanisées plombées, ou cadmiées ou tout autre métal qui produit des fumées toxiques.
10. Ne pas souder en présence de vapeurs de chlore provenant d'opérations de dégraissage, nettoyage ou pistolage. La chaleur ou les rayons de l'arc peuvent réagir avec les vapeurs du solvant pour produire du phosgène (gas fortement toxique) ou autres produits irritants.
11. Pour obtenir de plus amples renseignements sur la sûreté, voir le code "Code for safety in welding and cutting" CSA Standard W 117.2-1974.

## PRÉCAUTIONS DE SÛRETÉ POUR LES MACHINES À SOUDER À TRANSFORMATEUR ET À REDRESSEUR

1. Relier à la terre le châssis du poste conformément au code de l'électricité et aux recommandations du fabricant. Le dispositif de montage ou la pièce à souder doit être branché à une bonne mise à la terre.
2. Autant que possible, l'installation et l'entretien du poste seront effectués par un électricien qualifié.
3. Avant de faire des travaux à l'intérieur de poste, la débrancher à l'interrupteur à la boîte de fusibles.
4. Garder tous les couvercles et dispositifs de sûreté à leur place.

# I - MASTER TABLE OF CONTENTS FOR ALL SECTIONS - I

	Page
<b>Safety</b> .....	<b>.i-iv</b>
<b>Installation</b> .....	<b>Section A</b>
<b>Operation</b> .....	<b>Section B</b>
<b>Accessories</b> .....	<b>Section C</b>
<b>Maintenance</b> .....	<b>Section D</b>
<b>Theory of Operation</b> .....	<b>Section E</b>
<b>Troubleshooting and Repair</b> .....	<b>Section F</b>
<b>Electrical Diagrams</b> .....	<b>Section G</b>
<b>Parts Manual</b> .....	<b>P-282</b>

**Installation** ..... **A-1**

    Technical Specifications ..... A-2

    Safety Precautions ..... A-3

    Location ..... A-3

    Stacking/Tilting ..... A-3

    Electrical Input Connections ..... A-4

    Ground Connection ..... A-4

    Input Power Supply Connections ..... A-4

    Reconnect Procedure ..... A-5

    Reconnect Panel Board Positions ..... A-5/A-7

    Output Connections ..... A-8

    Connection for Semi-Automatic/Automatic Wire Feeder Control ..... A-9

Return to Master TOC

Return to Master TOC

Return to Master TOC

Return to Master TOC

## TECHNICAL SPECIFICATIONS - IDEALARC DC-600

### INPUT - THREE PHASE ONLY

<u>Standard Voltage</u> 208/230/416/460/575/3/60	<u>Input Current at Rated Output</u> 125/113/63/57/45
---	--

### RATED OUTPUT

<u>Duty Cycle</u>	<u>AMPS</u>	<u>Volts at Rated Amps</u>
100%	600	44
60%	680	44
50%	750	44

### OUTPUT

<u>Mode</u>	<u>Current Range</u>	<u>Maximum Open Circuit Voltage</u>	<u>Auxiliary Power</u>
Constant Current Constant Voltage	90 to 850 Amps 70 to 850 Amps	72 VDC 55 VDC	115 VAC, 8 Amps

### RECOMMENDED INPUT WIRE AND FUSE SIZES

Input Voltage / Frequency	Fuse (Super Lag) or Breaker Size	Input Ampere Rating on Nameplate	Type 75°C Copper Wire in Conduit AWG (IEC) Sizes	Type 75°C Copper Ground Wire in Conduit AWG (IEC) Sizes
208/60	175	125	2 (35mm <sup>2</sup> )	6 (16 mm <sup>2</sup> )
230/60	175	113	2 (35mm <sup>2</sup> )	6 (16 mm <sup>2</sup> )
416/60	100	63	6 (16mm <sup>2</sup> )	8 (10 mm <sup>2</sup> )
460/60	90	57	6 (16mm <sup>2</sup> )	8 (10 mm <sup>2</sup> )
575/60	80	45	6 (16mm <sup>2</sup> )	8 (10 mm <sup>2</sup> )

### PHYSICAL DIMENSIONS

<u>Height</u> 30.75 in. (781 mm.)	<u>Width</u> 22.25 in. (567 mm.)	<u>Depth</u> 39.0 in. (988 mm.)	<u>Weight</u> 522 lbs. (237 kg.)
---	--	---------------------------------------	--



Read entire Installation Section before installing the IDEALARC DC-600.

## SAFETY PRECAUTIONS

### ⚠ WARNING

## ELECTRIC SHOCK CAN KILL.



- Only qualified personnel should install this machine.

- Turn the input power OFF at the disconnect switch or fuse box before working on the equipment.

- Do not touch electrically hot parts.

- Always connect the IDEALARC DC-600 grounding terminal to a good electrical earth ground.

- Set the IDEALARC DC-600 Power ON/OFF PUSH BUTTON to OFF position when connecting power cord to input power.

DO NOT stack the IDEALARC DC-600 on another type of machine.

Follow these guidelines when stacking:

1. Select a firm, level surface capable of supporting the total weight of up to three machines (1570 pounds/712 kilograms).
2. Set the bottom machine in place.
3. Stack the second machine on top of it by aligning the two holes in the base rails of the second machine with the two pins on top front of the bottom machine.
4. Repeat process for third machine.

NOTE: The machines must be stacked with the Case Front of each machine flush with each other. See Figure A.1.

**FIGURE A.1**  
Stacking IDEALARC DC-600 machines

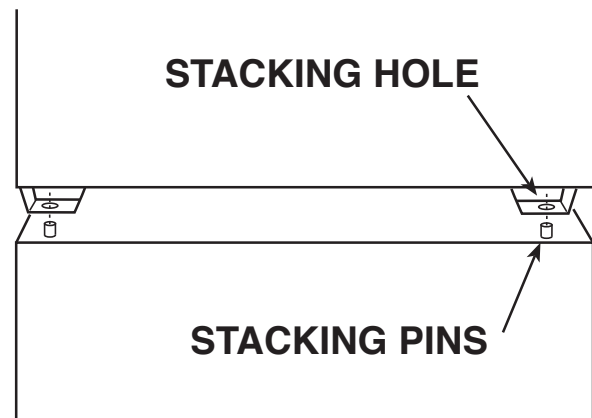

## SELECT PROPER LOCATION

Place the IDEALARC DC-600 where clean air can freely circulate in through the front intake and out through the rear louvers. Dirt, dust, or any foreign material that can be drawn into the machine should be kept at a minimum. Not following these precautions can result in the nuisance shutdown of the machine because of excessive operating temperatures.

## STACKING

Three IDEALARC DC-600 machines can be stacked.

DO NOT stack more than three machines in one grouping.

## TILTING

The IDEALARC DC-600 must be placed on a stable, level surface so it will not topple over.

## ELECTRICAL INPUT CONNECTIONS

Before installing the machine check that the input supply voltage, phase, and frequency are the same as the voltage, phase, and frequency as specified on the welder Rating Plate located on the Case Back Assembly. Input power supply entry is through the hole in the Case Back Assembly. See Figure A.2 for the location of the machine's input cable entry opening, Input Contactor (CR1), and reconnect panel assembly for dual voltage machines.

**FIGURE A.2**  
Rear Panel

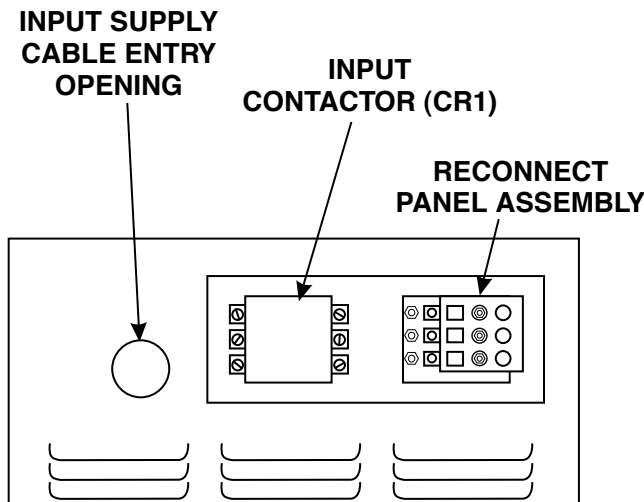

## FUSE AND WIRE SIZES

Protect the input circuit with the super lag fuses or delay type circuit breakers listed on the **Technical Specifications** page of this manual for the machine being used. They are also called inverse time or thermal/magnetic circuit breakers.

**DO NOT** use fuses or circuit breakers with a lower amp rating than recommended. This can result in “nuisance” tripping caused by inrush current even when machine is not being used for welding at high output currents.

Use input and grounding wire sizes that meet local electrical codes or see the **Technical Specifications** page in this manual.

## GROUND CONNECTION

Ground the frame of the machine. A ground terminal marked with the symbol ( $\oplus$ ) is located inside the Case Back of the machine near the input contactor. Access to the Input Box Assembly is at the upper rear of the machine. See your local and national electrical codes for proper grounding methods.

## INPUT POWER SUPPLY CONNECTIONS

A qualified electrician should connect the input power supply leads.

1. Follow all national and local electrical codes.
2. Use a three-phase line.
3. Remove Input Access Door at upper rear of machine.
4. Follow Input Supply Connection Diagram located on the inside of the door.
5. Connect the three-phase AC power supply leads L1, L2, and L3 to the input contactor terminals in the Input Box Assembly by passing them thru the three aligned .50” diameter holes in the baffle and tighten them in the terminal connectors. Be sure to close the baffle by inserting the tab into the slot in the baffle. See Figure A.3.

**FIGURE A.3**  
Input Power Supply Connections

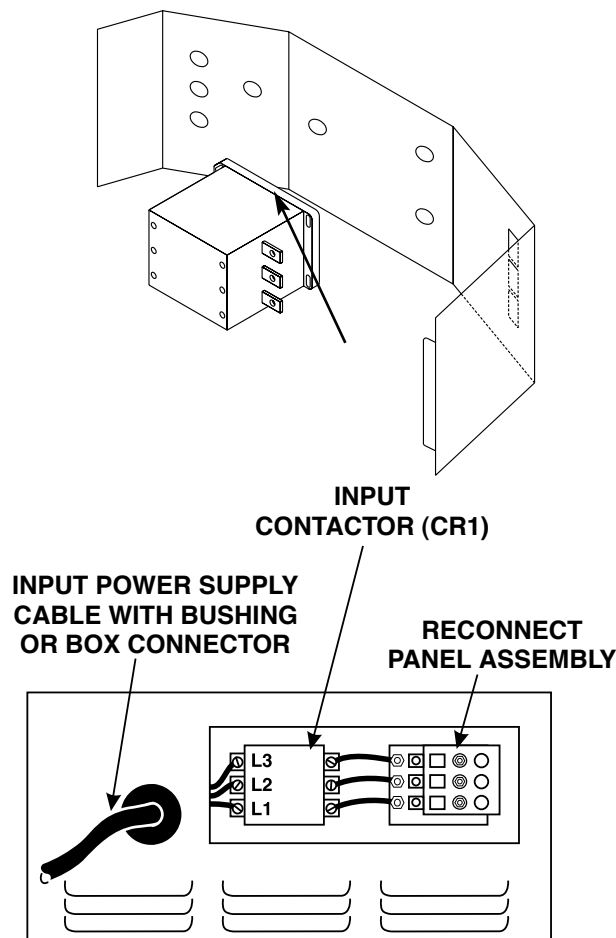

## RECONNECT PROCEDURE

Multiple voltage machines are shipped connected to the highest input voltage listed on the machine's rating plate. Before installing the machine, check that the Reconnect Panel in the Input Box Assembly is connected for the proper voltage.

### ⚠ CAUTION

Failure to follow these instructions can cause immediate failure of components within the machine.

To reconnect a multiple voltage machine to a different voltage, remove input power and change the position of the reconnect board on the Reconnect Panel. Follow The Input Connection Diagram located on the inside of Case Back Input Access Door. These connection diagrams for the following codes are listed below.

1. For codes 9773MSP, 9910M, 9776M, 9780M, see Figure A.4.
2. For code 9778M, see **Figure A.5**.
3. For code 9779M, see **Figure A.6**.
4. For code 9774, see **Figure A.7**.
5. For code 9793MSP, see **Figure A.8**.
6. For codes not listed, see the Input Connection Diagram pasted on the inside of the Case Back Input Access Door.

**FIGURE A.4 - Reconnect Panel Board Positions for Dual Voltage Machines**

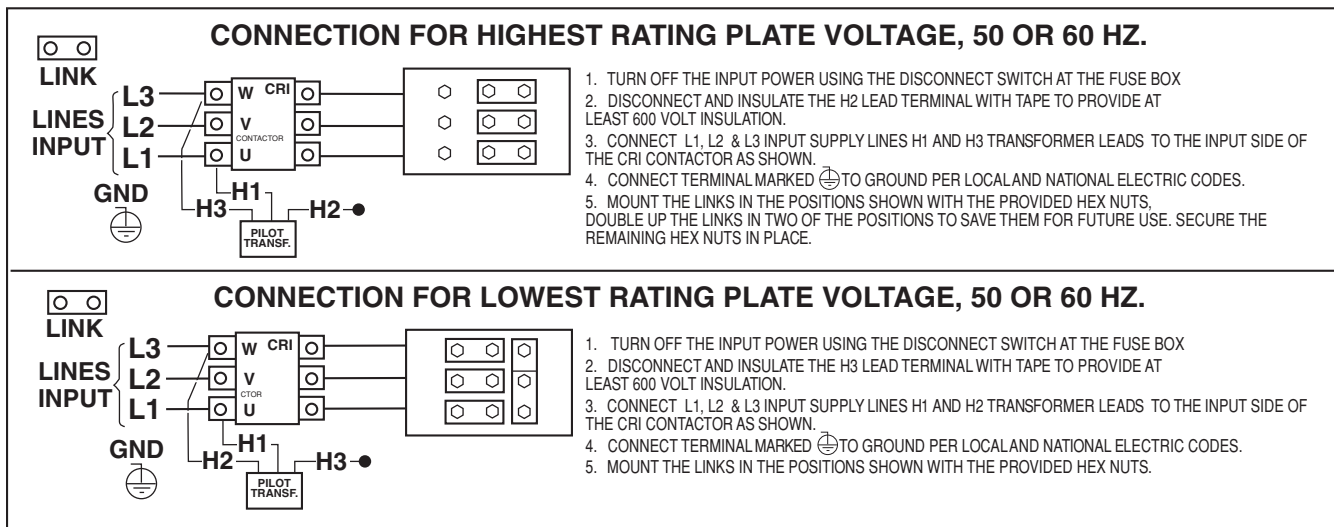

**FIGURE A.5 - Reconnect Panel Board Positions for 220/380/440 VAC Machines**

<p style="text-align: center;"><b>CONNECTION FOR 440 VOLTS 50 OR 60 HZ. (460V 60HZ)</b></p>	<ol style="list-style-type: none"> <li>1. TURN OFF THE INPUT POWER USING THE DISCONNECT SWITCH AT THE FUSE BOX</li> <li>2. DISCONNECT AND INSULATE THE H2 &amp; H3 LEAD TERMINALS SEPARATELY WITH TAPE TO PROVIDE AT LEAST 600 VOLT INSULATION.</li> <li>3. CONNECT L1, L2 &amp; L3 INPUT SUPPLY LINES H1 AND H4 CONTROL TRANSFORMER LEADS TO THE INPUT SIDE OF THE CRI CONTACTOR AS SHOWN.</li> <li>4. CONNECT TERMINAL MARKED Ⓢ TO GROUND PER LOCAL AND NATIONAL ELECTRIC CODES.</li> <li>5. MOUNT THE LINKS IN THE POSITIONS SHOWN: DOUBLE OR TRIPLE STACK THE LINKS IN THREE POSITIONS. CONNECT THE FLEX LEAD AS SHOWN: POSITIONING THE LUGS TO MAINTAIN MAXIMUM CLEARANCE TO THE LINKS. INSTALL AND TIGHTEN ALL OF THE HEX NUTS.</li> </ol>
<p style="text-align: center;"><b>CONNECTION FOR 380 VOLTS, 50 OR 60 HZ.</b></p>	<ol style="list-style-type: none"> <li>1. TURN OFF THE INPUT POWER USING THE DISCONNECT SWITCH AT THE FUSE BOX</li> <li>2. DISCONNECT AND INSULATE THE H2 &amp; H4 LEAD TERMINALS SEPARATELY WITH TAPE TO PROVIDE AT LEAST 600 VOLT INSULATION.</li> <li>3. CONNECT L1, L2 &amp; L3 INPUT SUPPLY LINES H1 AND H3 CONTROL TRANSFORMER LEADS TO THE INPUT SIDE OF THE CRI CONTACTOR AS SHOWN.</li> <li>4. CONNECT TERMINAL MARKED Ⓢ TO GROUND PER LOCAL AND NATIONAL ELECTRIC CODES.</li> <li>5. MOUNT THE LINKS IN THE POSITIONS SHOWN: DOUBLE UP THE LINKS IN TWO OF THE POSITIONS, LOOP THE POSITIONS. INSTALL AND TIGHTEN ALL OF THE HEX NUTS.</li> </ol>
<p style="text-align: center;"><b>CONNECTION FOR 220 VOLTS, 50 OR 60 HZ.</b></p>	<ol style="list-style-type: none"> <li>1. TURN OFF THE INPUT POWER USING THE DISCONNECT SWITCH AT THE FUSE BOX</li> <li>2. DISCONNECT AND INSULATE THE H3 &amp; H4 LEAD TERMINALS SEPARATELY WITH TAPE TO PROVIDE AT LEAST 600 VOLT INSULATION.</li> <li>3. CONNECT L1, L2 &amp; L3 INPUT SUPPLY LINES H1 AND H2 CONTROL TRANSFORMER LEADS TO THE INPUT SIDE OF THE CRI CONTACTOR AS SHOWN.</li> <li>4. CONNECT TERMINAL MARKED Ⓢ TO GROUND PER LOCAL AND NATIONAL ELECTRIC CODES.</li> <li>5. MOUNT THE LINKS IN THE POSITIONS SHOWN. LOOP THE FLEX LEAD IN THE POSITION SHOWN. INSTALL AND TIGHTEN ALL OF THE HEX NUTS.</li> </ol>

**FIGURE A.6 - Reconnect Panel Board Positions for 380/460, 500/575 VAC Machines**

<p style="text-align: center;"><b>CONNECTION FOR 380/460 VOLTAGES</b></p>	<p style="text-align: center;"><b>CONNECTION FOR 500/575 VOLTAGES</b></p>
<ol style="list-style-type: none"> <li>1. DISCONNECT AND INSULATE THE H3 LEAD TERMINAL WITH TAPE TO PROVIDE AT LEAST 600 VOLT INSULATION.</li> <li>2. CONNECT H2 LEAD TO CONTACTOR.</li> <li>3. CONNECT L1, L2 &amp; L3 INPUT SUPPLY LINES TO THE INPUT SIDE OF THE CRI CONTACTOR AS SHOWN.</li> <li>4. CONNECT TERMINAL MARKED Ⓢ TO GROUND PER NATIONAL ELECTRIC CODES.</li> <li>5. REMOVE THE HEX NUTS AND POSITION LINKS AS SHOWN. REPLACE AND TIGHTEN ALL HEX NUTS</li> </ol>	<ol style="list-style-type: none"> <li>1. DISCONNECT AND INSULATE THE H2 LEAD TERMINAL WITH TAPE TO PROVIDE AT LEAST 600 VOLT INSULATION.</li> <li>2. CONNECT H3 LEAD TO CONTACTOR.</li> <li>3. CONNECT L1, L2 &amp; L3 INPUT SUPPLY LINES TO THE INPUT SIDE OF THE CRI CONTACTOR AS SHOWN.</li> <li>4. CONNECT TERMINAL MARKED Ⓢ TO GROUND PER NATIONAL ELECTRIC CODES.</li> <li>5. REMOVE THE HEX NUTS AND POSITION LINKS AS SHOWN, REPLACE AND TIGHTEN ALL HEX NUTS</li> </ol>

**FIGURE A.7 - Reconnect Panel Board Positions for Single Voltage Machines**

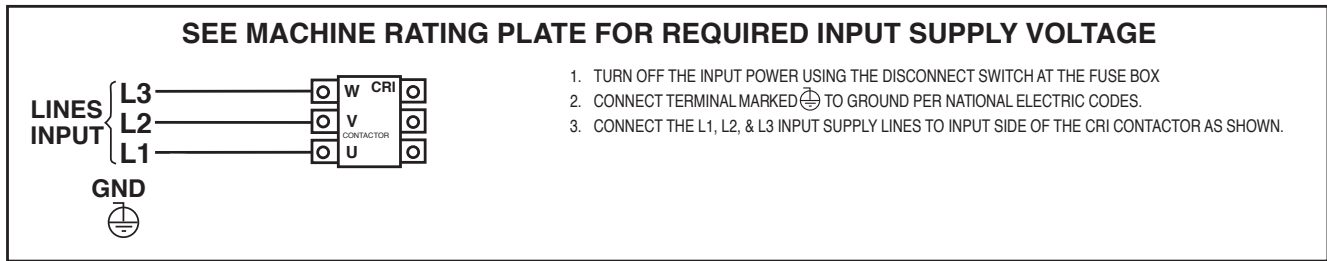

**FIGURE A.8 - Reconnect Panel Board Positions for 230/460/575 VAC Machines**

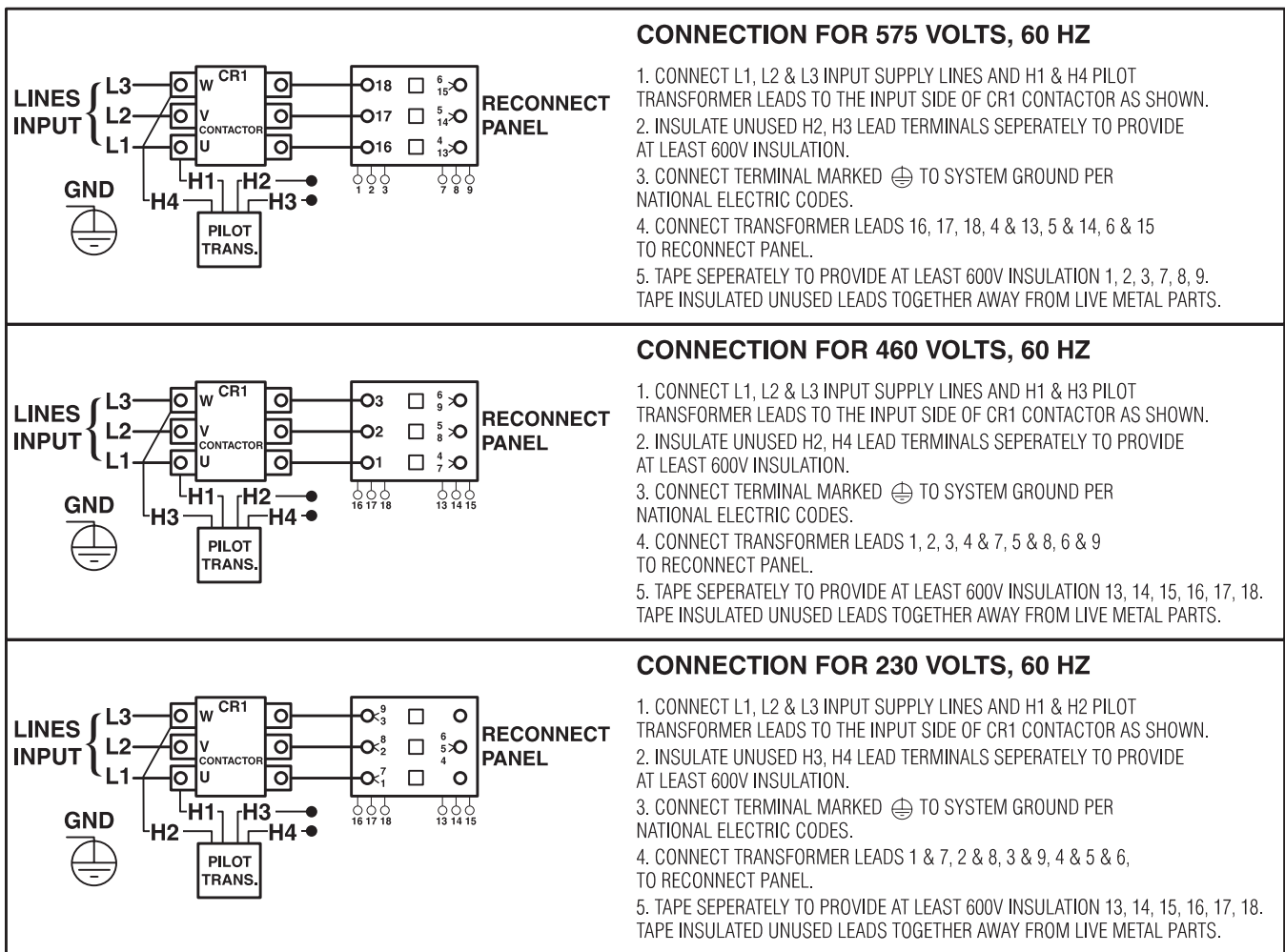

Return to Section TOC

Return to Master TOC

## OUTPUT CONNECTIONS

See Table A.1 for recommended IDEALARC DC-600 cable sizes for combined lengths of electrode and work cables.

**TABLE A.1**  
**IDEALARC DC-600 Cable Sizes for Combined Lengths of Electrode and Work Cable (Copper)**  
**at 100% Duty Cycle**

Cable Length	Parallel Cables	Cable Size
Lengths up to 150 ft. (46m)	2	1/0 (53mm <sup>2</sup> )
150 ft.(46m) to 200 ft (61m)	2	2/0 (67mm <sup>2</sup> )
200 ft.(61m) to 250 ft.(76m)	2	3/0 (85mm <sup>2</sup> )

### Connect Electrode and Work Leads to Output Terminals.

1. Set the ON/OFF PUSH BUTTON to OFF.
2. Locate the retractable strain relief loops directly below the output terminals in the lower right and lower left corners of the Case Front Assembly. See Figure A.9.
3. Pull out the retractable strain relief loops.
4. Insert the electrode lead through the loop directly below the desired polarity (positive or negative). Pull through enough cable to reach the output terminals.
5. Connect electrode lead to the desired terminal (positive/negative).
6. Tighten the output terminal nut with a wrench.
7. Connect the work lead to the other output terminal following steps 4-6.

**FIGURE A.9 - Output Terminals**

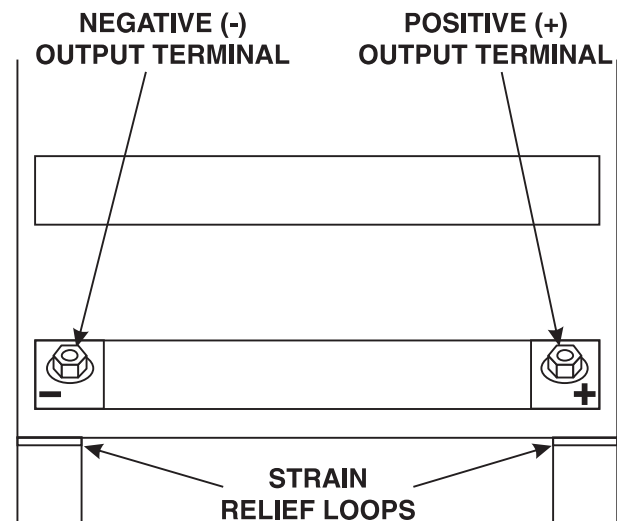

### Connection For Semi-Automatic or Automatic Wire Feeder Control

NOTE: See the **ACCESSORIES** Section of this manual for specific instructions on connecting the following semi-automatic and automatic wire feeders:

- LN-7
  - LN-8
  - LN-9
- } Semi-Automatic Wire Feeders
- NA-3
  - NA-5
- } Automatic Wire Feeders
- LT-7
  - LT-56
- } Tractors

### Connection for Stick Welding and Air/Carbon Arc Cutting Operation

#### ⚠ WARNING

THE OUTPUT TERMINALS ARE ENERGIZED AT ALL TIMES WHEN THE IDEALARC DC-600 IS CONNECTED FOR STICK WELDING AND AIR/CARBON ARC CUTTING.

---

1. Set ON/OFF PUSH BUTTON to OFF.
2. Locate and open the hinged access door on the Front Case Assembly.
3. If necessary, disconnect all wire feeder control cable connections from the DC-600 terminal strip.
4. Remove the leads from the unit by pulling them through and out of the strain relief loops.
5. Connect a jumper wire from terminal #2 to terminal #4 on the terminal strip.
6. Set the Welding Mode Switch to the VV position for both stick welding and air/carbon arc cutting.

NOTE: To use the IDEALARC DC-600 for both stick welding / air/carbon arc cutting, AND semi-automatic / automatic welding, the optional Multi-Process Switch (K804) must be used. See the **ACCESSORIES** Section of this manual for instructions on installing and using the Multi-Process Switch. When the Multi-Process Switch is not used, all control, work, and electrode leads from semi-automatic or automatic wire feeders must be disconnected from the IDEALARC DC-600 before connecting the machine for stick welding or air/carbon arc cutting.

Return to Section TOC

Return to Section TOC

Return to Section TOC

Return to Section TOC

Return to Master TOC

Return to Master TOC

Return to Master TOC

Return to Master TOC

IDEALARC® DC-600





**Operation** ..... **B-1**

    Operating Instructions ..... B-2

    General Description ..... B-3

    Recommended Processes and Equipment ..... B-3

    Operational/Design Features and Controls ..... B-3

    Welding Capability ..... B-4

    Controls and Settings ..... B-5

    Operating Steps ..... B-6

    Remote Control ..... B-6

    Welding Procedure Recommendations ..... B-6

    Operation with Wire Feeders ..... B-7/B-9

Return to Master TOC

Return to Master TOC

Return to Master TOC

Return to Master TOC

## OPERATING INSTRUCTIONS

Read and understand entire section before operating machine.

---

### SAFETY PRECAUTIONS

#### **WARNING**



#### **ELECTRIC SHOCK** can kill.

- Do not touch electrically live parts or electrode with skin or wet clothing.
  - Insulate yourself from work and ground.
  - Always wear dry insulating gloves.
- 



#### **FUMES AND GASES** can be dangerous.

- Keep your head out of fumes.
  - Use ventilation or exhaust to remove fumes from breathing zone.
- 



#### **WELDING, CUTTING and GOUGING SPARKS** can cause fire or explosion

- Keep flammable material away.
  - Do not weld, cut or gouge on containers that have held combustibles.
- 



#### **ARC RAYS** can burn.

- Wear eye, ear and body protection.

Observe additional Safety Guidelines detailed in the beginning of this manual.

IDEALARC® DC-600



## GENERAL DESCRIPTION

The IDEALARC DC-600 is an SCR controlled three phase welding and cutting power source. It uses a single range potentiometer to control:

- Submerged Arc Semi-Automatic or Automatic Welding
- Open Arc Semi-Automatic or Automatic Welding
- Stick Welding (Standard on All Machines)
- Air/Carbon Arc Cutting (Carbon Rod Sizes up to 3/8" Diameter)

The IDEALARC DC-600 has a three-position Welding Mode Switch to enable the user to operate in one of three modes:

- Constant Voltage (CV) Innershield
- Constant Voltage (CV) Submerged Arc
- Variable Voltage (VV - Constant Current) Submerged Arc

The IDEALARC DC-600 can be easily connected to wire feeding equipment, including:

- Semi-automatic wire feeders LN-7, LN-8, and LN-9
- Automatic wire feeders NA-3 and NA-5
- Tractors LT-56 and LT-7

The optional Multi-Process Switch allows the user to switch between semi-automatic or automatic welding and stick welding or air/carbon arc cutting without disconnecting the wire feeder equipment control, electrode, and work leads.

## RECOMMENDED PROCESSES AND EQUIPMENT

The IDEALARC DC-600 is recommended for the following welding or cutting processes within its output capacity of 70 amps to 850 amps in the Constant Voltage mode and 90 amps to 850 amps in the Variable Voltage (Constant Current) mode:

- Submerged Arc Semi-Automatic or Automatic Welding
- Open Arc Semi-Automatic or Automatic Welding
- Stick Welding (Standard on All Machines)
- Air/Carbon Arc Cutting (Carbon Rod Sizes up to 3/8" Diameter)

## OPERATIONAL FEATURES AND CONTROLS

The IDEALARC DC-600 comes with the following standard controls:

- ON/OFF PUSH BUTTON
- OUTPUT CONTROL POTENTIOMETER
- OUTPUT CONTROL SWITCH (Remote or Machine Control)
- WELDING MODE SWITCH
- CONTROL CIRCUIT POLARITY SWITCH
- POWER SOURCE PILOT LIGHT
- DC AMMETER (OPTIONAL)
- DC VOLTMETER (OPTIONAL)

## DESIGN FEATURES AND ADVANTAGES

The following list of design features will help you understand the machine's total capabilities and how you can take advantage of them to get maximum use of your machine.

- Excellent arc characteristics for optimum constant voltage submerged arc and Innershield welding performance.
- A control circuit designed to provide good starting for a large variety of processes and procedures.
- Output Control Potentiometer that provides easy single range continuous control.
- Output Control Switch that provides simple switching from local to remote control.
- Red neon pilot light to confirm that the Input Contactor is energized.

- Auxiliary power source to provide 115-volt AC power (1000 VA) to wire feeding equipment.
- Multi-functional terminal strip for easy connection of wire feeding control cables and switching between CV Innershield and CV Submerged Arc welding when using the Dual Process or Dual Procedure Kits.
- Recessed output terminals to avoid any person or object from accidentally coming into contact with the output terminals and labeled positive and negative for easy identification.
- Thermostatically protected power source.
- Electronic protection circuit to protect power source against overloads.
- Input line voltage compensation to provide an essentially constant output.
- SCR electronically controlled welder output provides extra long life, especially for highly repetitive welding applications.
- Three circuit solid state control system provides maximum performance and circuit protection.
- Low profile case provides maximum use of space.
- Convenient access to all controls.
- Output lead strain relief loops to prevent terminal and cable damage.
- Easily removed case side, even when stacked.
- Outdoor operation because enclosure is designed with air intake louvers that keep dripping water from entering the unit. Transformer, SCR bridge, and choke have special corrosion resistant paint for added protection.

## WELDING CAPABILITY

The IDEALARC DC-600 has the following duty cycle ratings:

If the duty cycle is exceeded, a thermal protector will shut off the output of the machine until it cools to the normal operating temperature.

Duty Cycle	Amps	Volts	Hertz
50% (Based on 10 min.)	750	44	50/60
60% (Based on 10 min.)	680	44	50/60
100%	600	44	50/60

## CONTROLS AND SETTINGS

All operator controls and adjustments are located on the Case Front Assembly of the IDEALARC DC-600. See Figure B.1 for the location of each control.

FIGURE B.1 - CONTROL PANEL KEYS

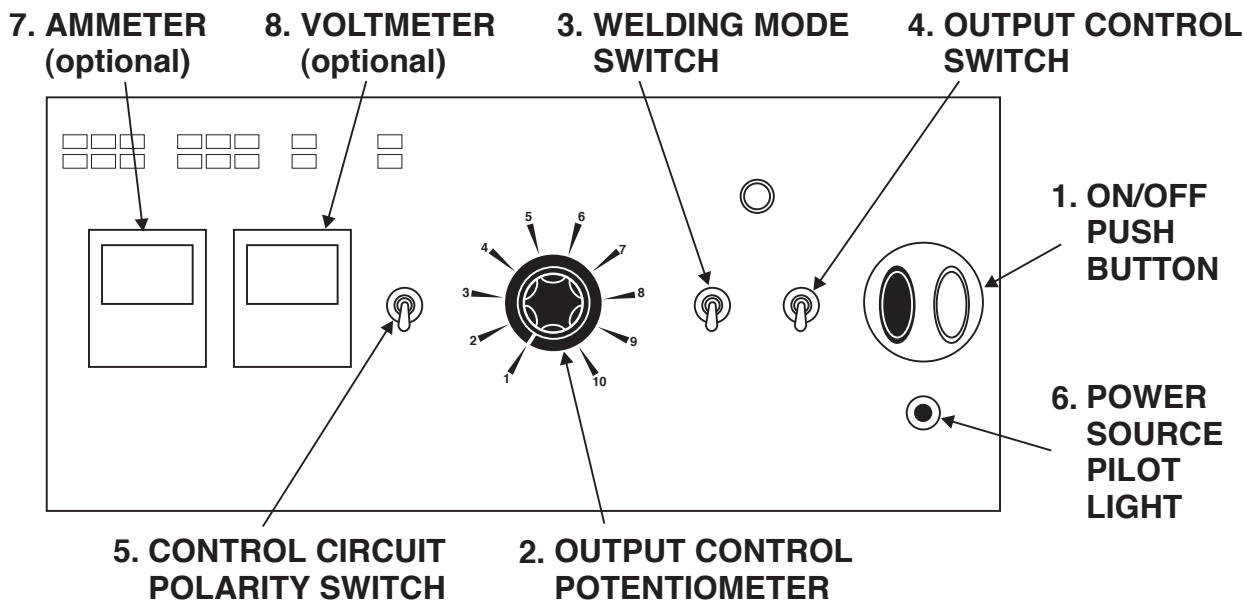

1. **ON/OFF PUSH BUTTON:** This push button turns the machine ON or OFF.
2. **OUTPUT CONTROL POTENTIOMETER:** This control provides tapered, continuous control of the machine output. The control can be rotated from minimum to maximum while machine is under load to adjust the machine output.
3. **WELDING MODE SWITCH:** This toggle switch is used to select the proper welder performance characteristics for the process being used. There are three modes: CV (Constant Voltage) Innershield, CV (Constant Voltage) Submerged Arc, and VV (Variable Voltage) CC (Constant Current) Submerged Arc.
4. **OUTPUT CONTROL SWITCH:** This toggle switch is used to switch between "Output Control at DC-600" for local control of machine output and "Output Control Remote" for remote control of machine output.
5. **CONTROL CIRCUIT POLARITY SWITCH:** This toggle switch is used to set power source voltage sensing polarity to match the polarity to which the electrode is connected to the machine. This provides the correct polarity at the terminal strip for correct operation of the automatic wire feeding equipment powered by the auxiliary power from the power source.
6. **POWER SOURCE PILOT LIGHT:** The red neon light glows when the power source input contactor is energized.
7. **AMMETER:** An optional ammeter is available.
8. **VOLTMETER:** An optional voltmeter is available.

## OPERATING STEPS

The following procedures are for using the IDEAL-ARC DC-600 in the local control mode of operation. For remote control of the machine, see the Remote Control of Machine Operation section.

Before operating the machine, make sure you have all materials needed to complete the job. Be sure you are familiar with and have taken all possible safety precautions before starting work. It is important that you follow these operating steps each time you use the machine.

1. Turn on the main AC power supply to the machine.
2. Set the CONTROL CIRCUIT POLARITY SWITCH to the appropriate position.
  - Set toggle to "Electrode Negative" position if the electrode is connected to the negative (-) output terminal.
  - Set toggle to "Electrode Positive" position if the electrode is connected to the positive (+) output terminal.
3. Set the WELDING MODE SWITCH to welding process being used.
  - CV Innershield
  - CV Submerged Arc
  - VV (CC)
4. Push the ON/OFF PUSH BUTTON to the ON position
  - The red neon light glows.
  - The fan starts.
5. Set Output Control Potentiometer to desired voltage or current.
6. Make the weld (NOTE: Terminal #2 and #4 must be connected together to energize the machine output).

## REMOTE CONTROL OF MACHINE OPERATION

The toggle switch on the control panel labeled "Output Control at DC-600" — "Output Control Remote" gives the operator the option of controlling the machine output from a remote location. If in the Remote position a wire feeder with remote control capabilities or a remote control device such as a K775 must be connected to terminals 75, 76, and 77. Refer to **Accessories** Section for wire feeder remote information.

## WELDING PROCEDURE RECOMMENDATIONS

Select Welding Mode Switch position based on type of welding to be done.

1. Innershield Welding/Other Open Arc Processes: Use the CV Innershield mode.
2. Submerged Arc Welding: Use the CV Submerged Arc mode. If performing high speed welding, switch between the CV Submerged Arc and the CV Innershield mode and use the mode that produces the best welding results.
3. Air/Carbon Arc Cutting / Stick Welding / High Current, Large Puddle Submerged Arc Welding: Use the VV (CC) mode. When the IDEALARC DC-600 is used for Air/Carbon Arc cutting, the OUTPUT CONTROL POTENTIOMETER should be set to "9" initially. Based on the size of the carbon being used or the process, turn the potentiometer to a lower setting as required by the process. You can use carbon rods up to 3/8" in diameter at currents as high as 750 amps with excellent arc control. The welder protection circuit protects the machine from extremely high short circuiting pulses.

## SEMI-AUTOMATIC AND AUTOMATIC WIRE FEEDING WITH A IDEALARC DC-600 AND WIRE FEEDERS

When using the IDEALARC DC-600 with semi-automatic or automatic wire feeding equipment and for stick welding or air/carbon arc cutting, it is recommended that the optional MULTI-PROCESS SWITCH be used. This switch permits you to easily change the polarity of the connected wire feeding equipment or switch to stick welding or air/carbon arc cutting.

### NA-3 AUTOMATIC WIRE FEEDER

1. Set the DC-600 Output Control Switch to Remote. NOTE: Later model NA-3 automatic wire feeders are capable of cold starts when the NA-3 Mode switch is in the CV or VV(CC) mode position. Some earlier models are capable of cold starting only in the VV(CC) mode position. Cold starting enables you to inch the wire down to the work, automatically stop, and automatically energize the flux hopper valve.
2. Set the DC-600 welding mode switch for the desired process: CV Submerged Arc, CV Innershield mode or VV(CC) mode.
3. Set the NA-3 mode Switch Position to either CV or VV(CC) to match the DC-600 mode selected in step 2.
4. Refer to the NA-3 operators manual for instructions on how to use the NA-3 in conjunction with the DC-600.
5. Follow the following guidelines for good arc striking detailed below for each welding mode.

### GOOD ARC STRIKING GUIDELINES FOR THE NA-3 WITH THE IDEALARC DC-600 IN THE CV INNERSHIELD, CV SUBMERGED ARC OR VV(CC) WELDING MODES.

Following are some basic arc striking techniques that apply to all wire feed processes. Using these procedures should provide trouble-free starting. These procedures apply to single, solid wires and Innershield wires.

1. Cut the electrode to a sharp point.
2. Set the NA-3 Open Circuit Voltage Control to the same dial setting as the Arc Voltage Control. If this is a new welding procedure, a good starting point is to set the Open Circuit Voltage Control to # 6.

NOTE: The open circuit voltage of the IDEALARC DC-600 varies from approximately 16 volts to 56 volts in the CV Innershield or CV Submerged Arc modes. The open circuit voltage is constant in the VV(CC) mode.

3. Run a test weld. Set proper current, voltage, and travel speed.
  - a. For the best starting performance, the NA-3 Open Circuit Voltage Control and Voltage Control setting should be the same. Set the Inch Speed Control for the slowest inch speed possible.
  - b. To adjust the Open Circuit Voltage Control to get the best starting performance, make repeated starts observing the NA-3 voltmeter.

When the voltmeter pointer swings smoothly up to the desired arc voltage, without undershooting or overshooting the desired arc voltage, the Open Circuit Voltage Control is set properly.

If the voltmeter pointer overshoots the desired voltage and then returns back to the desired voltage, the Open Circuit Voltage Control is set too high. This can result in a bad start where the wire tends to "Blast off."

If the voltmeter pointer hesitates before coming up to the desired voltage, the Open Circuit Voltage Control is set too low. This can cause the electrode to stub.

4. Start and make the weld.
  - a. Cold starts. For cold starts, be sure the work piece is clean and the electrode makes positive contact with the work piece.
  - b. Hot "On the Fly" starts. For hot starts, travel should begin before the wire contacts the work piece.



### ARC STRIKING WITH IDEALARC DC-600 AND THE NA-3 START BOARD

When electrical strikeouts exceed 1 3/4" (44.4mm) an NA-3 Start Board may be required to improve arc striking.

When the NA-3 Start Board is used to improve arc striking, use the following procedures:

1. Set start time at 0.
2. Set NA-3 start current and start voltage at mid-range.
3. Set the NA-3 output current and voltage to the proper settings for the welding procedure to be used.
4. Turn the Start Board Timer to maximum.
5. Set Start Board current and voltage control.
  - a. Set the Start Board current control to 1 1/2 dial numbers below that set on the NA-3 current control.
  - b. Set the Start Board voltage control equal with the NA-3 voltage control setting.

NOTE: These Start Board current and voltage settings result in a start up current that is lower than the NA-3 current setting and approximately equal with the NA-3 voltage setting for the desired welding procedure.

6. Establish the correct arc striking procedure with the NA-3 Start Board timer set at maximum.
  - a. For the best starting performance, the NA-3 Open Circuit Voltage Control and Voltage Control setting should be the same. Set the Inch Speed Control for the slowest inch speed possible.
  - b. To adjust the Open Circuit Voltage Control to get the best starting performance, make repeated starts observing the NA-3 voltmeter.

When the voltmeter pointer swings smoothly up to the desired arc voltage, without undershooting or overshooting the desired arc voltage, the Open Circuit Voltage Control is set properly.

If the voltmeter pointer overshoots the desired voltage and then returns back to the desired voltage, the Open Circuit Voltage Control is set too high. This can result in a bad start where the wire tends to "Blast off."

If the voltmeter pointer hesitates before coming up to the desired voltage, the Open Circuit Voltage Control is set too low. This can cause the electrode to stub.

- c. Set NA-3 Start Board current and voltage as close to the welding procedure current and voltage as possible.

NOTE: The Start Board current and voltage should be as close as possible to the welding procedure current and voltage, while still getting satisfactory starts.

- d. Set the start time to as low a time as possible while still getting satisfactory starts.

7. Start and make the weld.



## IDEALARC DC-600 POWER SOURCE SETTING WHEN CONNECTED TO NA-5 WIRE FEEDER

When using the IDEALARC DC-600 with the NA-5 wire feeder, set the controls on the IDEALARC DC-600 as follows for the best performance:

1. Turn OFF main AC input power supply to the IDEALARC DC-600.
2. Connect the electrode cables to terminal polarity to be used.
3. Set the CONTROL CIRCUIT POLARITY SWITCH to the same polarity as the electrode cable connection.
4. Set the OUTPUT CONTROL SWITCH to REMOTE.
5. Set the IDEALARC DC-600 WELDING MODE SWITCH to the position that matches the welding process being used.
  - a. For submerged arc welding, set WELDING MODE SWITCH TO CV SUBMERGED ARC position.
  - b. For all open arc welding processes set WELDING MODE SWITCH TO CV INNERSHIELD position.

## LN-8 SEMI-AUTOMATIC WIRE FEEDER

To use the LN-8 Semi-Automatic Wire Feeder with IDEALARC DC-600

1. Set the IDEALARC DC-600 WELDING MODE SWITCH to either CV Innershield mode or CV Submerged Arc mode depending on the welding process being used.
2. Set the IDEALARC DC-600 OUTPUT CONTROL SWITCH to the REMOTE position.
3. Set the LN-8 Welding Mode Switch to the CV position. The LN-8 Welding Mode Switch is located on the variable voltage (CC) board.
4. Refer to the LN-8 Operator's Manual for instructions on how to use the LN-8.

## LN-7 AND LN-9 SEMI-AUTOMATIC WIRE FEEDERS OR OTHER CONSTANT WIRE FEEDERS

To use the LN-7, LN-9, or other constant wire feed speed semi-automatic wire feeders with IDEALARC DC-600

1. Set the IDEALARC DC-600 WELDING MODE SWITCH to either CV Innershield mode or CV Submerged Arc mode depending on the welding process being used.

NOTE: These semi-automatic wire feeders cannot be used in the VV(CC) mode.

2. Set the IDEALARC DC-600 OUTPUT CONTROL SWITCH.
  - a. LN-7: Use either an optional K775 Remote Control Box Assembly or set the IDEALARC DC-600 OUTPUT CONTROL SWITCH in the Local position.
  - b. LN-9: Refer to the LN-9 Operator's Manual for instructions of how to use the LN-9.

Return to Section TOC      Return to Section TOC      Return to Section TOC  
Return to Master TOC      Return to Master TOC      Return to Master TOC

IDEALARC® DC-600



**Accessories** ..... **C-1**

Options/Accessories ..... C-2

Multi-Process Switch ..... C-2/C-3

Undercarriage (K817P, K842) ..... C-4

Meters ..... C-4

Paralleling Kit ..... C-4

Connection Wire Feeders ..... C-5/C-8

Return to Master TOC

Return to Master TOC

Return to Master TOC

Return to Master TOC

## OPTIONS/ACCESSORIES

- Multi-Process Switch (K804)
  - Remote Control Box Assembly (K775)
  - Undercarriages (K817, K817R, K842)
- Semi-Automatic and Automatic Wire Feeders
- LN-7
  - LN-8
  - LN-9
- } Semi-Automatic Wire Feeders
- NA-3
  - NA-5
- } Automatic Wire Feeders

## MULTI-PROCESS SWITCH

The MULTI-PROCESS SWITCH gives you the ability to:

- Switch between "stick welding or air/carbon arc cutting" and using a semi-automatic or automatic wire feeder.
- Change the polarity of a semi-automatic or automatic wire feeder without changing any electrical cable connections.

See Figure C.1

The MULTI-PROCESS SWITCH has two sets of output terminals. You connect the wire feeder unit cables to the set of terminals on the left side of the box and the stick or air/carbon arc cables to the set of terminals on the right side (facing the front of the machine) as shown in Figure C.1.

When the MULTI-PROCESS SWITCH is in the "Stick or Air/Carbon Arc" position, only those terminals are energized. The wire feeder nozzle or gun and electrode are not electrically "hot" when in this mode.

Follow these steps to install the MULTI-PROCESS SWITCH:

1. Confirm that the IDEALARC DC-600 ON/OFF PUSH BUTTON is in the OFF position.
2. Disconnect main AC input power to the IDEALARC DC-600.
3. Open the terminal strip access door located on the Case Front Assembly.
4. Remove the two front, middle screws that secure the two side panels of the machine. See Figure C.2.

FIGURE C.1 - MULTI-PROCESS SWITCH

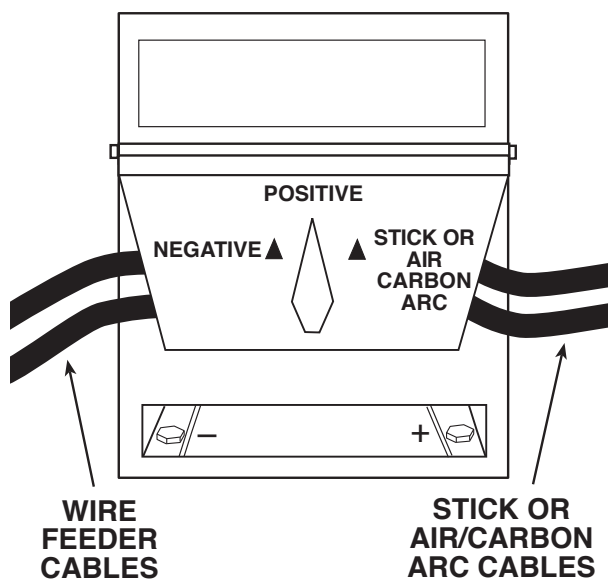
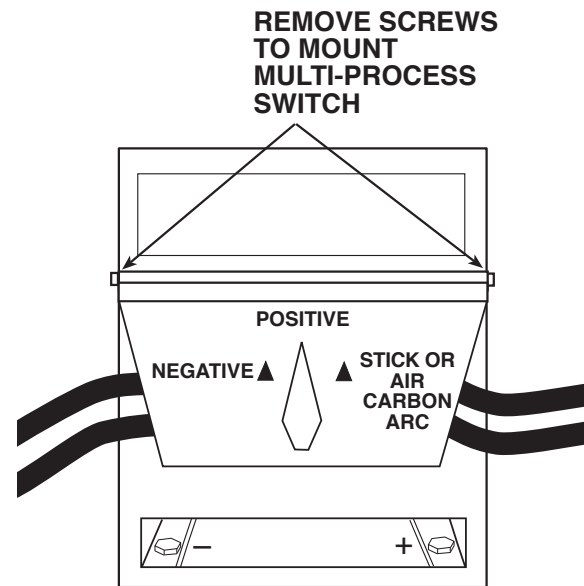

FIGURE C.2 - SIDE PANEL REMOVAL



IDEALARC® DC-600



- Attach the MULTI-PROCESS SWITCH bracket across the front of the machine with the flange down. Use the long, self-tapping screws and lock washers provided. The bracket should be on the outside of the side panel. See Figure C.3.

NOTE: If the machine does not have any holes in the front of the machine, use the switch template and drill two .153" diameter holes.

- Position the MULTI-PROCESS SWITCH at the front of the machine. See Figure C.3.
- Route the MULTI-PROCESS SWITCH control leads through the strain-relief box connectors and into the terminal strip. The wire feeder control cable is routed through the strain-relief box connector also. See Figure C.3.

- Connect the control leads from the MULTI-PROCESS SWITCH to terminals #2 and #4 on the IDEALARC DC-600's terminal strip.
- Position the MULTI-PROCESS SWITCH flush with the front of the machine about 2" lower than the bracket. Slide the switch straight up to the bracket.
- Check that the bottom of the switch is hooked behind the top of the bottom louver.
- Connect the right cable from the MULTI-PROCESS SWITCH (facing the front of the machine) to the IDEALARC DC-600 positive (+) output terminal. See Figure C.4.
- Connect the left cable from the MULTI-PROCESS SWITCH (facing the front of the machine) to the IDEALARC DC-600 negative (-) output terminal. See Figure C.4.

**FIGURE C.3 - ATTACHING THE MULTI-PROCESS SWITCH BRACKET**

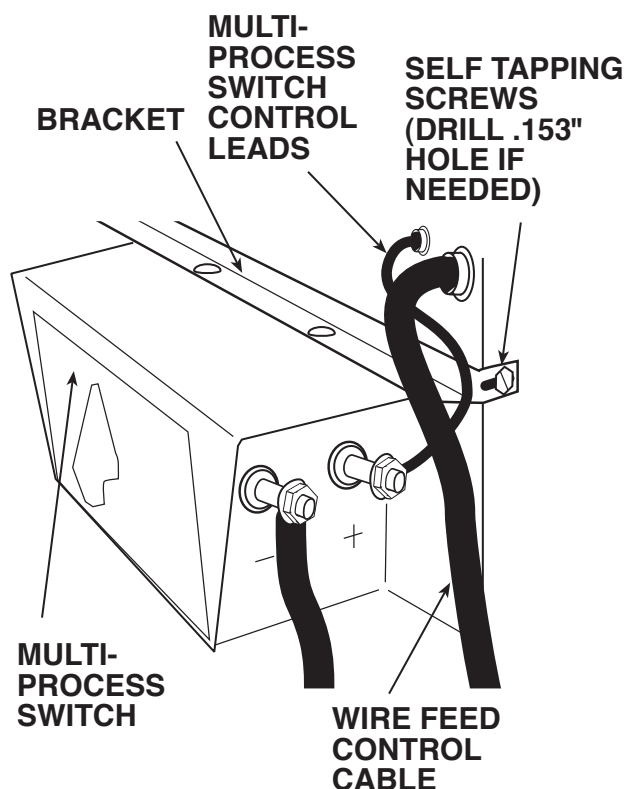

**FIGURE C.4 - MULTI-PROCESS SWITCH CABLE CONNECTIONS.**

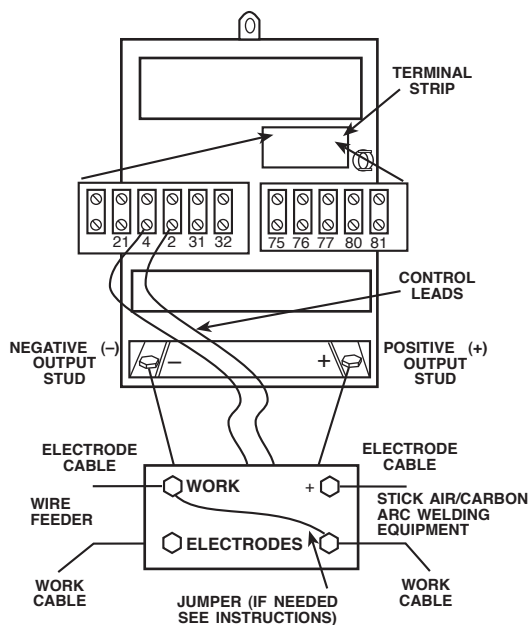

13. Connect the wire feeder electrode and work cables. See **Figure C.4**.

- a. Insert the wire feeder electrode and work cables through the strain relief loop on the left side of the IDEALARC DC-600 (facing the front of the machine).
- b. Connect the wire feeder electrode and work cables to the electrode and work terminals on the left side of the MULTI-PROCESS SWITCH.

NOTE: When using Dual Process Kits K317 or K318, connect the electrode and work cables to these terminals instead of the power source output terminals. See connection diagrams for details.

14. Connect wire feeder control cable to the terminal strip of the IDEALARC DC-600.

NOTE: Connect the control cable ground lead to the frame terminal marked (⊕).

NOTE: See the connection diagram for the wire feeder being used for connection instructions.

15. Connect stick or air/carbon arc electrode and work cable. See **Figure C.4**.

- a. Insert the electrode and work cables through the strain relief loop on the right side (facing the front of the machine) of the IDEALARC DC-600.
- b. Connect the electrode cable to the "Positive" terminal on the right side of the MULTI-PROCESS SWITCH.
- c. Connect the work cable to the "Negative" terminal on the right side of the MULTI-PROCESS SWITCH.

NOTE: The instructions above are for connecting the stick polarity positive. To change the polarity, turn the IDEALARC DC-600 OFF, and reverse the cables.

NOTE: When it is not necessary to have separate ground cables for stick and semi-automatic or automatic welding, connect a jumper from the MULTI-PROCESS SWITCH "Work" terminal to the MULTI-PROCESS SWITCH "negative" terminal. See **Figure C.4**.

To operate the MULTI-PROCESS SWITCH, refer to the operating instructions on the switch nameplate.

## UNDERCARRIAGE (K817P, K842)

The IDEALARC DC-600 is designed for use with the Lincoln K817, K817R, or K842 Undercarriage. Complete installation instructions are included with the undercarriage. When any of the undercarriages are installed, the IDEALARC DC-600 lift bail is no longer functional. Do not attempt to lift the machine with the undercarriage attached. The undercarriage is designed for moving the machine by hand only. Mechanized towing can lead to injury and/or damage to the IDEALARC DC-600.

## METERS

Optional factory-installed voltmeter and ammeter are available.

## PARALLELING KIT FOR DC-600

Kit S20428 - field installation only, permits paralleling of two DC-600's for welding currents of up to 1200 amps, 100% duty cycle. (See instructions shipped with the kit for installation and operation.)

## CONNECTIONS FOR SEMI-AUTOMATIC OR AUTOMATIC WIRE FEEDER CONTROL

1. Set the ON/OFF PUSH BUTTON to OFF.
2. Locate and open the hinged access door on the Front Case Assembly.
3. Insert control cable through the strain relief box connector and pull enough cable through to reach the terminal strip.
4. Connect the automatic wire feeder control cable to the terminal strip. See corresponding connection diagram in this Section of the manual, or the instructions included with the wire feeder.
5. Connect the wire feeder grounding wire to the chassis ground screw marked with the symbol ( $\text{⏏}$ ).

NOTE: The IDEALARC DC-600 Auxiliary Power Circuit supplies 115-volt AC power to the wire feeding equipment. The circuit has a 1000 volt ampere rating. An 8-amp slow blow fuse on the machine's control panel protects the auxiliary power supply from excessive overloads.

### CONNECTING THE NA-3 IDEALARC DC-600

1. Disconnect main AC input power to the IDEALARC DC-600.
2. Set IDEALARC DC-600 ON/OFF PUSH BUTTON to OFF.
3. Connect the wire feeder control cable leads to the IDEALARC DC-600 terminal strip as shown in Figure C.5.
4. Connect the wire feeder control cable ground lead to the frame terminal marked ( $\text{⏏}$ ).

NOTE: The IDEALARC DC-600 must be properly grounded.

FIGURE C.5 - NA-3 WIRE FEEDER CONNECTION TO THE IDEALARC DC-600

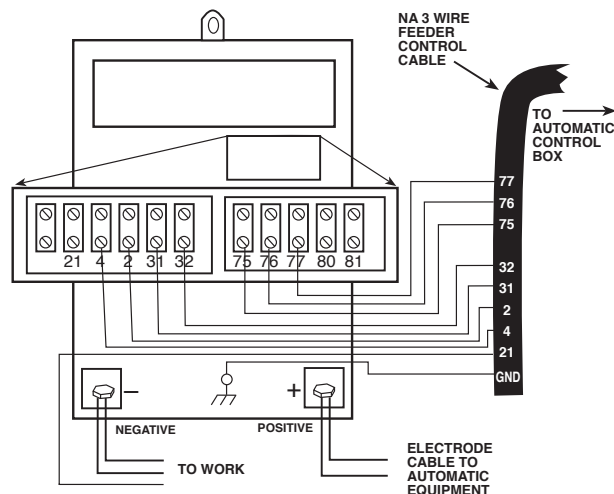

5. Extend wire feeder control cable lead # 21 so it can be connected directly to the work piece.
  - a. Make a bolted connection using AWG #14 or larger insulated wire. Tape the bolted connection with insulating tape.
  - b. An S-16586- X remote voltage sensing work lead is available for this purpose.
  - c. Keep the # 21 lead electrically separate from the work cable circuit and connection.
  - d. Tape the # 21 lead to work cable for ease of use.

NOTE: The connection diagram shown in Figure C.5 shows the electrode connected for positive polarity. To change polarity:

- a. Set the IDEALARC DC-600 ON/OFF PUSH BUTTON to OFF
- b. Move the electrode cable to the Negative (-) output terminal
- c. Move the work cable to the Positive (+) output terminal.
- d. Set the IDEALARC DC-600 CONTROL CIRCUIT POLARITY SWITCH to NEGATIVE.
- e. Reverse the leads at the back of the ammeter and voltmeter on the wire feeder automatic control box.

## CONNECTING THE NA-5 TO THE IDEALARC DC-600

NOTE: For optimum performance use the NA-5 with IDEALARC DC-600 codes 8288 and above.

1. Disconnect main AC input power to the IDEALARC DC-600.
2. Set the IDEALARC DC-600 ON/OFF PUSH BUTTON to OFF.
3. Connect the wire feeder control cable leads to the IDEALARC DC-600 terminal strip as shown in Figure C.6.

**FIGURE C.6 - NA-5 WIRE FEEDER CONNECTION TO THE IDEALARC DC-600**

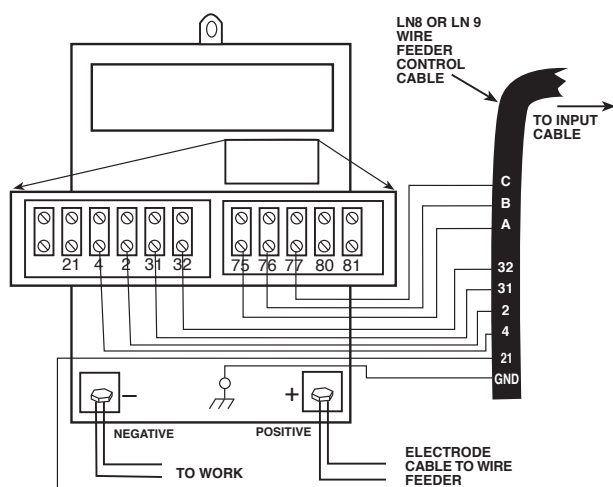

NOTE: If using a K215 control cable, connect control cable leads #75, #76, and #77 to the matching #75, #76, and #77 terminals on the terminal strip of the IDEALARC DC-600.

4. Connect the wire feeder control cable ground lead to the frame terminal marked (⏏).  
NOTE: The IDEALARC DC-600 must be properly grounded.

5. Extend wire feeder control cable lead # 21 so it can be connected directly to the work piece.
  - a. Make a bolted connection using AWG #14 or larger insulated wire. Tape the bolted connection with insulating tape.
  - b. An S-16586- X remote voltage sensing work lead is available for this purpose.
  - c. Keep the # 21 lead electrically separate from the work cable circuit and connection.
  - d. Tape the # 21 lead to work cable for ease of use.
6. Connect NA-5 wire feeder control jumpers on Voltage Control Board. See NA-5 Operator's Manual.
  - a. Connect red jumper on Voltage Control Board to pin "S."
  - b. Connect white jumper on Voltage Control Board to pin "B."

NOTE: The connection diagram shown in Figure C.6 shows the electrode connected for positive polarity. To change polarity:

- a. Set the IDEALARC DC-600 ON/OFF PUSH BUTTON to OFF.
- b. Move the electrode cable to the Negative (-) output terminal.
- c. Move the work cable to the Positive (+) output terminal.
- d. Set the IDEALARC DC-600 CONTROL CIRCUIT POLARITY SWITCH to NEGATIVE.

NOTE: For proper NA-5 operation, the electrode cables must be secured under the clamp bar on the left side of the NA-5 Control Box.



## CONNECTING THE LN-8 OR LN-9 TO THE IDEALARC DC-600

1. Disconnect AC input power to the IDEALARC DC-600.
2. Set the IDEALARC DC-600 ON/OFF PUSH BUTTON to OFF.
3. Connect the wire feeder control cable leads to the IDEALARC DC-600 terminal strip as shown in Figure C.7.
4. Connect the wire feeder control cable ground lead to the frame terminal marked (⏏).

NOTE: The IDEALARC DC-600 must be properly grounded.

5. Extend wire feeder control cable lead #21 so it can be connected directly to the work piece.
  - a. Make a bolted connection using AWG #14 or larger insulated wire. Tape the bolted connection with insulating tape.
  - b. An S-16586- X remote voltage sensing work lead is available for this purpose.
  - c. Keep the #21 lead electrically separate from the work cable circuit and connection.
  - d. Tape the #21 lead to work cable for ease of use.

NOTE: Using the extended #21 lead eliminates the need to use the LN-9's remote work lead accessory which has a direct work lead jack.

6. Connect LN-9 wire feeder control jumpers on Voltage Control board. See LN-9 Operator's Manual.
  - a. White jumper on Voltage Control Board to pin "S."
  - b. Blue jumper on Voltage Control Board to pin "B."

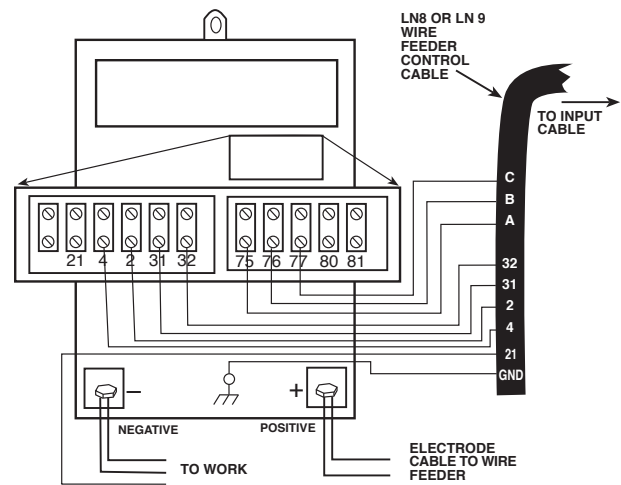

**FIGURE C.7 - LN-8 OR LN-9 WIRE FEEDER CONNECTION TO THE IDEALARC DC-600**

NOTE: On earlier units, the blue jumper on Voltage Control Board is connected to Pin "B" on Start Board.

NOTE: The connection diagram shown in Figure C.7 shows the electrode connected for positive polarity. To change polarity:

- a. Set the IDEALARC DC-600 ON/OFF PUSH BUTTON to OFF
- b. Move the electrode cable to the Negative (-) output terminal
- c. Move the work cable to the Positive (+) output terminal.
- d. Set the IDEALARC DC-600 CONTROL CIRCUIT POLARITY SWITCH to NEGATIVE.

## LN-7 IDEALARC DC-600

1. Disconnect main AC input power to the IDEALARC DC-600.
2. Set the IDEALARC DC-600 ON/OFF PUSH BUTTON to OFF.
3. Connect the wire feeder control cable leads to the IDEALARC DC-600 terminal strip as shown in Figure C.8.

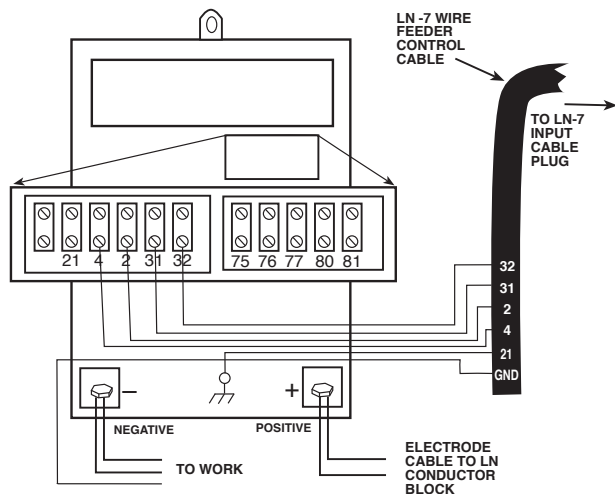

- b. An S-16586- X remote voltage sensing work lead is available for this purpose.
- c. Keep the #21 lead electrically separate from the work cable circuit and connection.
- d. Tape the #21 lead to work cable for ease of use.

NOTE: The connection diagram shown in Figure C.8 shows the electrode connected for positive polarity. To change polarity:

- a. Set the IDEALARC DC-600 ON/OFF PUSH BUTTON to OFF.
- b. Move the electrode cable to the Negative (-) output terminal.
- c. Move the work cable to the Positive (+) output terminal.
- d. Set the IDEALARC DC-600 CONTROL CIRCUIT POLARITY SWITCH to NEGATIVE.

**FIGURE C.8 - LN-7 WIRE FEEDER CONNECTION TO THE IDEALARC DC-600**

4. Connect the wire feeder control cable ground lead to the frame terminal marked (⏏).  
NOTE: The IDEALARC DC-600 must be properly grounded.
5. PERFORM THIS STEP ONLY IF THE LN-7 IS EQUIPPED WITH A METER KIT.

Extend wire feeder control cable lead #21 so it can be connected directly to the work piece.

- a. Make a bolted connection using AWG #14 or larger insulated wire. Tape the bolted connection with insulating tape.

NOTE: If the work cable length is less than 25 feet and the connections to the work piece are secure, then wire feeder control cable lead #21 can be connected directly to the DC-600 terminal strip.

IDEALARC® DC-600



**Maintenance** .....D-1

Safety Precautions .....D-2

Routine Maintenance .....D-2

Major Component Location .....D-3

Return to Master TOC

Return to Master TOC

Return to Master TOC

Return to Master TOC

## SAFETY PRECAUTIONS

### ⚠ WARNING

## ELECTRIC SHOCK CAN KILL.



Only qualified personnel should perform this maintenance.

Turn the input power OFF at the disconnect switch or fuse box before working on this equipment.

Do not touch electrically hot parts.

## ROUTINE AND PERIODIC MAINTENANCE

1. Disconnect input AC power supply lines to the machine before performing periodic maintenance, tightening, cleaning, or replacing parts. See *Figure D.1*

### Perform the following daily:

1. Check that no combustible materials are in the welding or cutting area or around the machine.
2. Remove any debris, dust, dirt, or materials that could block the air flow to the machine for cooling.
3. Inspect the electrode cables for any slits or punctures in the cable jacket, or any condition that would affect the proper operation of the machine.

### Perform Periodically:

Clean the inside of the machine with low pressure air stream. Clean the following parts. Refer to *Figure D.1*.

- Main transformer and choke.
- Electrode and work cable connections.
- SCR rectifier bridge and heat sink fins.
- Control board.
- Firing board.
- Fan Assembly.

NOTE: The fan motor has sealed bearings which require no maintenance.

FIGURE D.1 - MAJOR COMPONENT LOCATION

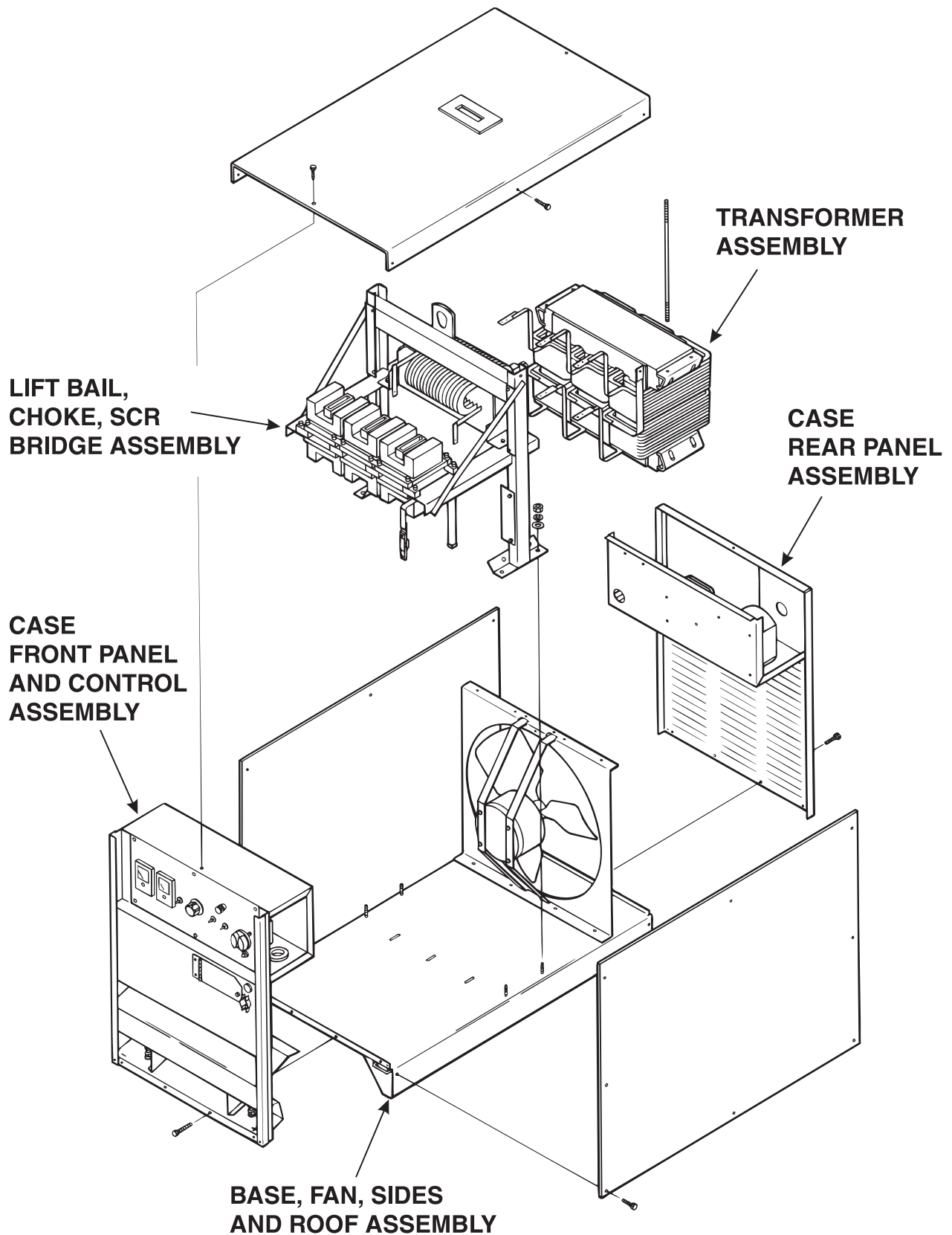

IDEALARC® DC-600



Return to Section TOC

Return to Section TOC

Return to Section TOC

Return to Section TOC

Return to Master TOC

Return to Master TOC

Return to Master TOC

Return to Master TOC

Return to Section TOC

Return to Section TOC

Return to Section TOC

Return to Section TOC

Return to Master TOC

Return to Master TOC

Return to Master TOC

Return to Master TOC

IDEALARC® DC-600



Return to Master TOC

Return to Master TOC

Return to Master TOC

Return to Master TOC

Theory of Operation .....E-1

Input Line Voltage, Contactor and Main Transformer .....E-2

Output, Rectification, Control and Feedback .....E-3

Protection Devices and Circuits (Contactor Hold-In) .....E-4

SCR Operation .....E-5

**FIGURE E.1 BLOCK LOGIC DIAGRAM**

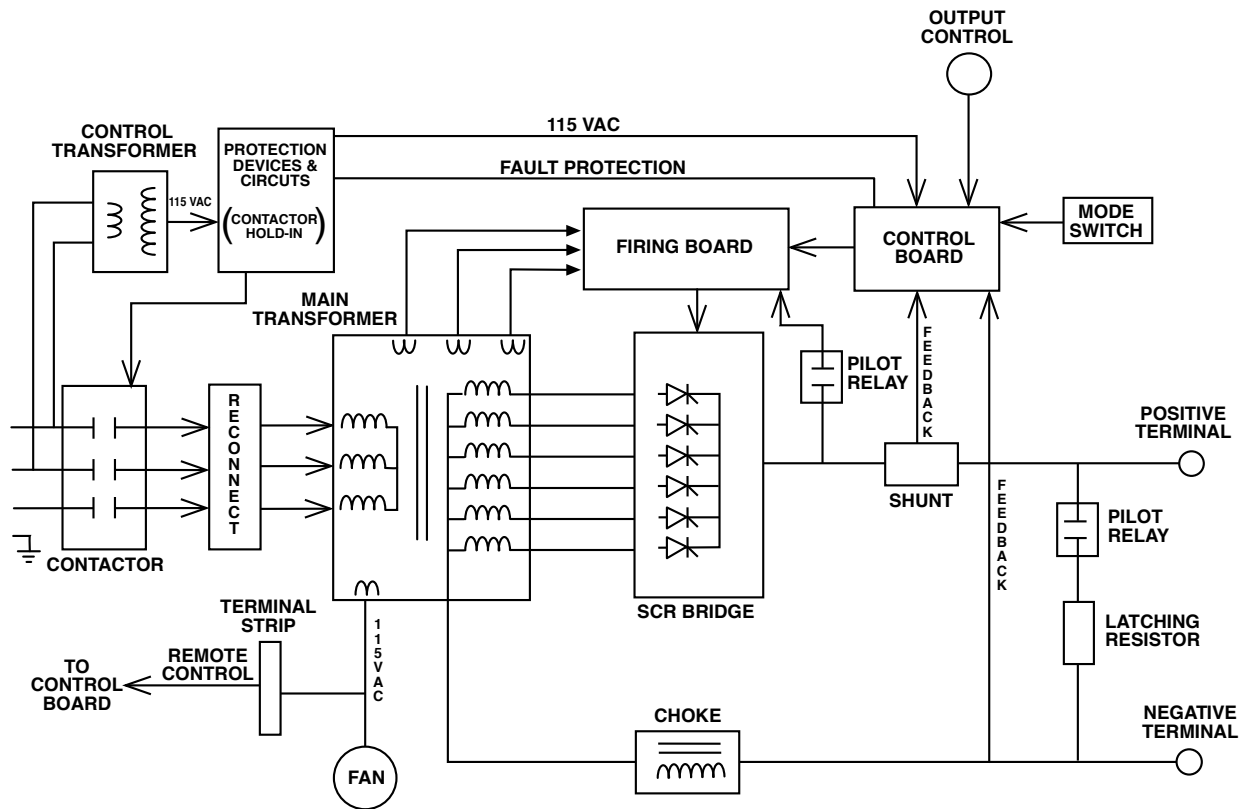

**IDEALARC® DC-600**



FIGURE E.2 Input Line Voltage, Contactor and Main Transformer

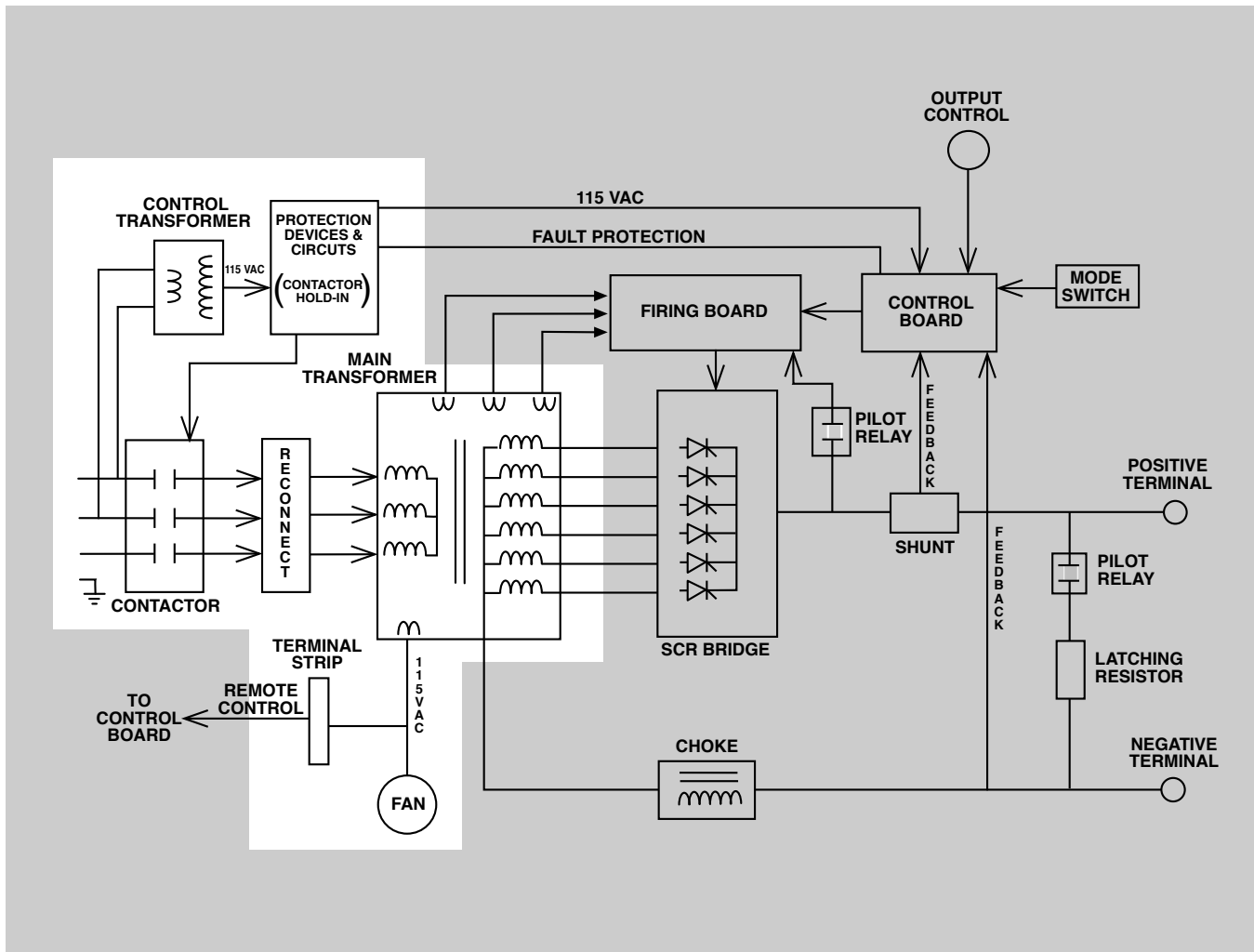

## INPUT LINE VOLTAGE, CONTACTOR AND MAIN TRANSFORMER

The desired three phase input power is connected to the DC-600 through an Input Contactor located in the input box at the rear of the machine. Two phases of the input line are also connected to the Control Transformer which supplies power to the Contactor Hold-In Circuit. The Contactor Hold-In Circuit will disable the Input Contactor if the DC-600 is overloaded or overheated.

A Reconnect Panel allows the user to configure the machine for the desired input voltage. This AC input voltage is applied to the primary of the Main Transformer.

The transformer changes the high voltage, low current input power to a low voltage, high current output. The finishes or "neutrals" of the main secondary coils are connected together and the six starts of the secondary windings are connected to the rectifier assembly. In addition the main transformer also has an isolated 115VAC auxiliary winding that supplies 115VAC to operate the cooling fan and offers 8 amps of auxiliary power to operate wire feeding equipment. The three 75VAC phase angle windings are also housed in the Main Transformer assembly. These windings provide power and "timing" to the firing board.

NOTE: Unshaded areas of Block Logic Diagram are the subject of discussion

IDEALARC® DC-600

LINCOLN  
ELECTRIC



FIGURE E.3 Output, Rectification, Control and Feedback

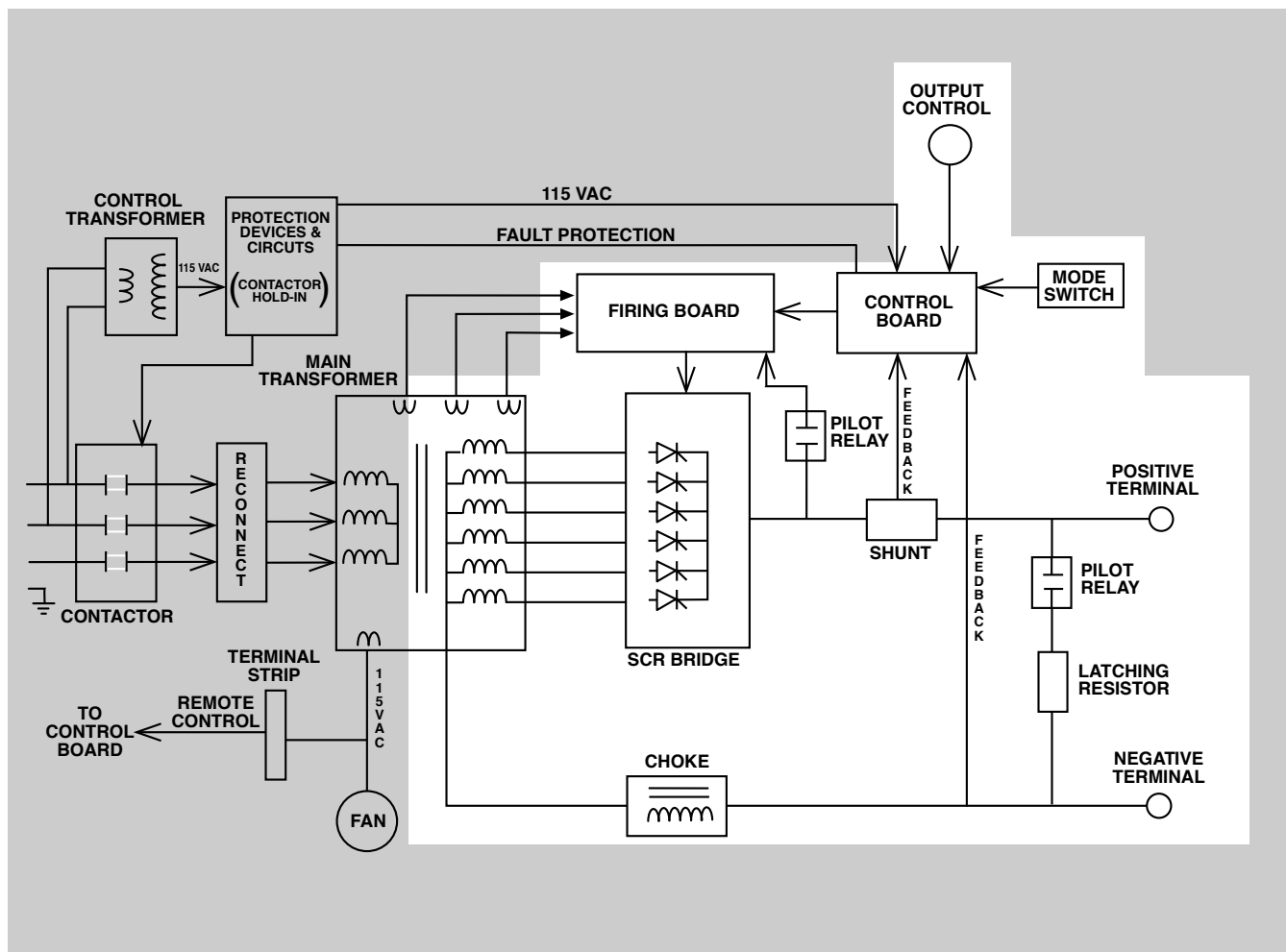

## OUTPUT, RECTIFICATION, CONTROL AND FEEDBACK

The neutrals of the Main Transformer secondary windings are connected together and the six starts are connected to the six SCR assemblies to form a six phase output. This six phase AC output from the Main Transformer secondary is rectified and controlled through the SCR bridge. Output current and voltage is sensed at the shunt and output terminals. This feedback information is processed in the control board. The control board compares the commands of the Mode switch and the Output Control Potentiometer (or Remote Control) with the feedback information and sends the appropriate signal to the Firing Board.

The Firing Board is a three phase circuit. Each phase provides two firing pulses, one for each of the two Silicon Controlled Rectifiers (SCR) controlled by that phase. The firing circuit supplies the proper amount of

energy to the gates of the power SCRs. When this energy is applied, at the correct time, the SCR will turn "ON". The amount of "ON" time versus "OFF" time determines the output of the machine. See **SCR Operation**.

The Pilot Relay signals the Firing Board circuit to supply gate pulses to the SCR Bridge. Closing of the Pilot Relay (a "dry" closure of leads #2 and #4) also brings the Latching Resistor into the machine output circuit. The Latching Resistor provides a pre-load for the SCR Bridge.

A Choke is connected between the neutral connection of the Main Transformer secondaries and the negative output terminal. This large inductor stores energy and provides filtering for the output of the DC-600.

FIGURE E.4 Protection Devices and Circuits (Contactor Hold-In)

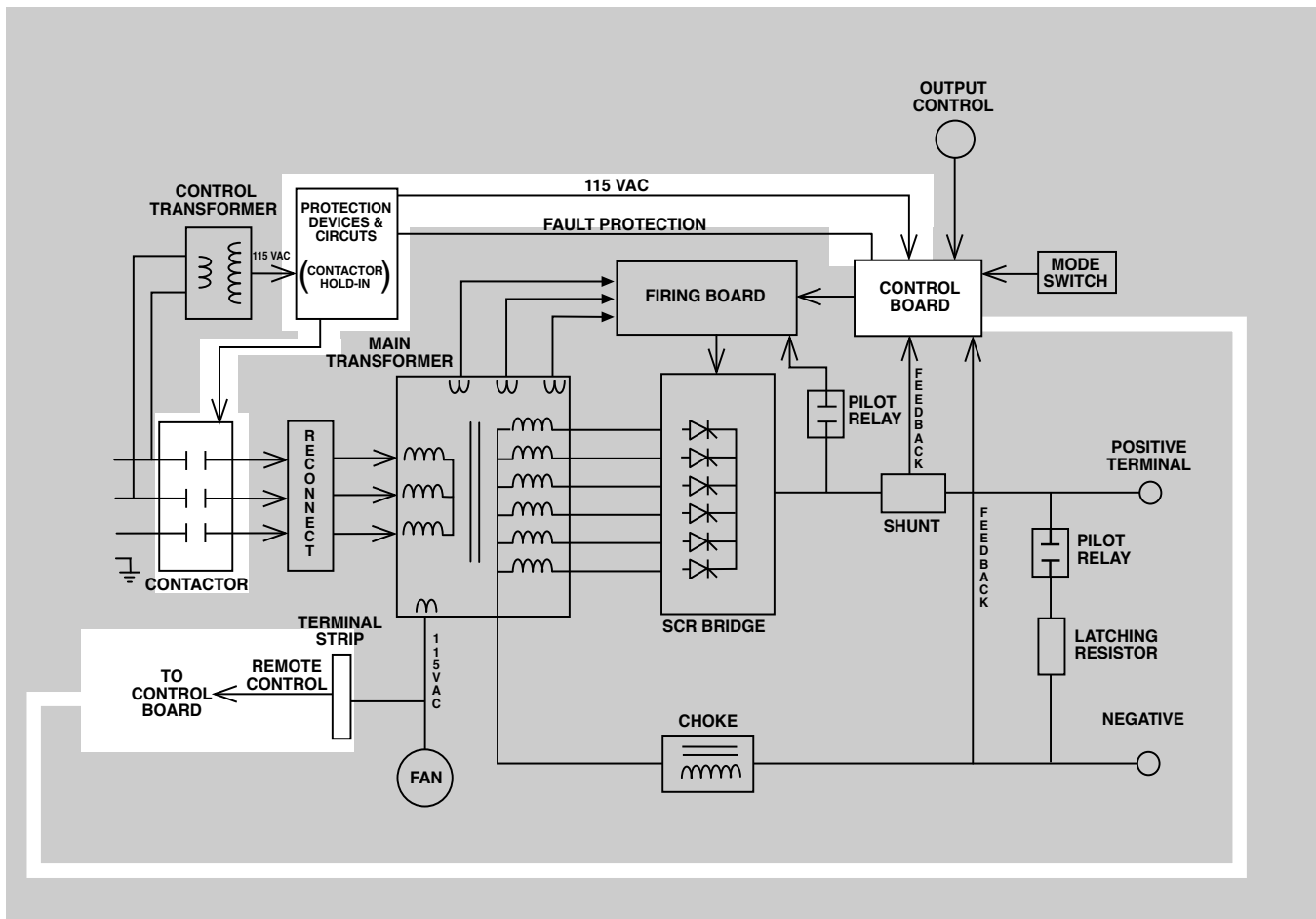

## PROTECTION DEVICES AND CIRCUITS (CONTACTOR HOLD-IN)

Two thermostats protect the DC-600 from excessive operating temperatures. Excessive operating temperatures may be caused by a lack of cooling air or operating the machine beyond the duty cycle and output rating. If excessive operating temperature should occur, the thermostat(s) will deactivate the input contactor, turning the machine off. The input contactor will remain open until the machine cools. The machine can then be restarted by operating the start push button.

Upon restart if the fan does not turn or the air intake louvers are obstructed, then the input power must be removed and the fan problem or air obstruction be corrected.

The DC-600 is also protected against high current overloads. This electronic protection circuit senses an overload on the power source and opens the input contactor should the overload remain for a predetermined time. If the overload is great the machine will shut down immediately. The input contactor will remain open until the start push button is operated.

The Remote Control circuit is also protected from "grounds" or voltage intrusions. If the #75, #76 or #77 leads come in contact with either of the machine's output cables, the DC-600 will only operate at a minimum output or the input contactor will open.

FIGURE E.5 SCR Operation

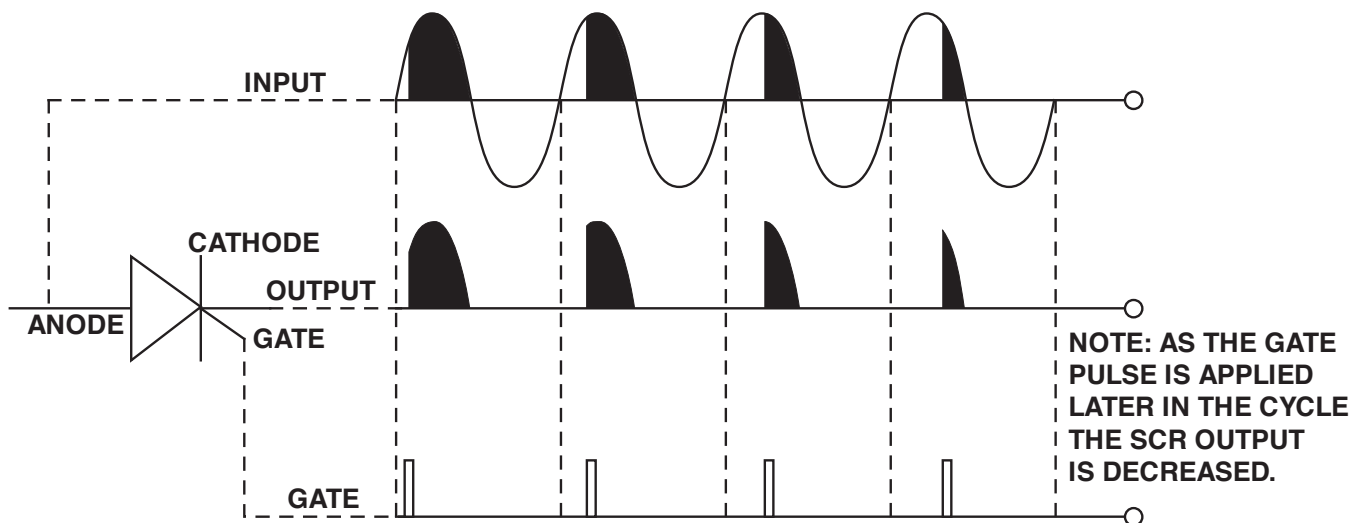

## SCR OPERATION

A silicon controlled rectifier (SCR) is a three terminal device used to control rather large currents to a load. An SCR acts very much like a switch. When a gate signal is applied to the SCR it is turned ON and there is current flow from anode to cathode. In the ON state the SCR acts like a closed switch. When the SCR is turned OFF there is no current flow from anode to cathode thus the device acts like an open switch. As the name suggests, the SCR is a rectifier, so it passes current only during positive half cycles of the AC supply. The positive half cycle is the portion of the sine wave in which the anode of the SCR is more positive than the cathode.

When an AC supply voltage is applied to the SCR, the device spends a certain portion of the AC cycle time in the on state and the remainder of the time in the off state. The amount of time spent in the ON state is controlled by the Gate.

An SCR is fired by a short burst of current into the gate. This gate pulse must be more positive than the cathode voltage. Since there is a standard PN junction between gate and cathode, the voltage between these terminals must be slightly greater than 0.6V. Once the SCR has fired it is not necessary to continue the flow of gate current. As long as current continues to flow from anode to cathode the SCR will remain on. When the anode to cathode current drops below a minimum value, called holding current, the SCR will shut off. This normally occurs as the AC supply voltage passes through zero into the negative portion of the sine wave. If the SCR is turned on early in the positive half cycle, the conduction time is longer resulting in greater SCR output. If the gate firing occurs later in the cycle the conduction time is less resulting in lower SCR output.

Return to Section TOC

Return to Section TOC

Return to Section TOC

Return to Section TOC

Return to Master TOC

Return to Master TOC

Return to Master TOC

Return to Master TOC

IDEALARC® DC-600



Return to Master TOC

Return to Master TOC

Return to Master TOC

Return to Master TOC

**Troubleshooting and Repair** .....F-1

    How to Use Troubleshooting Guide .....F-2

    PC Board Troubleshooting Procedures .....F-3

    Troubleshooting Guide .....F-4

    Test Procedures .....F-13

        Control Transformer (T2) Voltage Test .....F-13

        Main Transformer (T1) Voltage Test .....F-17

        Firing Board Test .....F-23

        Control Board Test .....F-31

        Static SCR Test .....F-37

        Active SCR Test .....F-41

    Voltage Waveforms .....F-45/F-50

    Removal & Replacement Procedures .....F-51

        Input Contactor (CR1) Cleaning/Replacement .....F-51

        SCR/SCR Output Bridge .....F-53

        Lift Bail Removal (Including Main Transformer, Choke and Output Bridge Assembly) .....F-57

        Transformer Removal from Lift Bail Assembly .....F-61

    Retest and Repair .....F-65/F-66

## HOW TO USE TROUBLESHOOTING GUIDE

**⚠ WARNING**

Service and Repair should only be performed by Lincoln Electric Factory Trained Personnel. Unauthorized repairs performed on this equipment may result in danger to the technician and machine operator and will invalidate your factory warranty. For your safety and to avoid Electrical Shock, please observe all safety notes and precautions detailed throughout this manual.

This Troubleshooting Guide is provided to help you locate and repair possible machine malfunctions. Simply follow the three-step procedure listed below.

**Step 1. LOCATE PROBLEM (SYMPTOM).**

Look under the column labeled "PROBLEM (SYMPTOMS)". This column describes possible symptoms that the machine may exhibit. Find the listing that best describes the symptom that the machine is exhibiting. Symptoms are grouped into the following categories: output problems, function problems, wire feeding problems, and welding problems.

**Step 2. PERFORM EXTERNAL TESTS.**

The second column labeled "POSSIBLE AREAS OF MISADJUSTMENT(S)" lists the obvious external possibilities that may contribute to the machine symptom. Perform these tests/checks in the order listed. In general, these tests can be conducted without removing the case wrap-around cover.

**Step 3. RECOMMENDED COURSE OF ACTION**

The last column labeled "Recommended Course of Action" lists the most likely components that may have failed in your machine. It also specifies the appropriate test procedure to verify that the subject component is either good or bad. If there are a number of possible components, check the components in the order listed to eliminate one possibility at a time until you locate the cause of your problem.

All of the referenced test procedures referred to in the Troubleshooting Guide are described in detail at the end of this chapter. Refer to the Troubleshooting and Repair Table of Contents to locate each specific Test Procedure. All of the specified test points, components, terminal strips, etc. can be found on the referenced electrical wiring diagrams and schematics. Refer to the Electrical Diagrams Section Table of Contents to locate the appropriate diagram.

**⚠ CAUTION**

If for any reason you do not understand the test procedures or are unable to perform the tests/repairs safely, contact the Lincoln Electric Service Department for technical troubleshooting assistance before you proceed. Call 1-888-935-3877.

## PC BOARD TROUBLESHOOTING PROCEDURES

**WARNING****ELECTRIC SHOCK  
can kill.**

- Have an electrician install and service this equipment. Turn the input power OFF at the fuse box before working on equipment. Do not touch electrically hot parts.

**CAUTION**

Sometimes machine failures appear to be due to PC board failures. These problems can sometimes be traced to poor electrical connections. To avoid problems when troubleshooting and replacing PC boards, please use the following procedure:

1. Determine to the best of your technical ability that the PC board is the most likely component causing the failure symptom.
2. Check for loose connections at the PC board to assure that the PC board is properly connected.
3. If the problem persists, replace the suspect PC board using standard practices to avoid static electrical damage and electrical shock. Read the warning inside the static resistant bag and perform the following procedures:

**PC board can be damaged by static electricity.**

- Remove your body's static charge before opening the static-shielding bag. Wear an anti-static wrist strap. For safety, use a 1 Meg ohm resistive cord connected to a grounded part of the equipment frame.

- If you don't have a wrist strap, touch an un-painted, grounded, part of the equipment frame. Keep touching the frame to prevent static build-up. Be sure not to touch any electrically live parts at the same time.

- Tools which come in contact with the PC board must be either conductive, anti-static or static-dissipative.

- Remove the PC board from the static-shielding bag and place it directly into the equipment. Don't set the PC board on or near paper, plastic or cloth which could have a static charge. If the PC board can't be installed immediately, put it back in the static-shielding bag.

- If the PC board uses protective shorting jumpers, don't remove them until installation is complete.

- If you return a PC board to The Lincoln Electric Company for credit, it must be in the static-shielding bag. This will prevent further damage and allow proper failure analysis.

4. Test the machine to determine if the failure symptom has been corrected by the replacement PC board.

**NOTE:** It is desirable to have a spare (known good) PC board available for PC board troubleshooting.

**NOTE:** Allow the machine to heat up so that all electrical components can reach their operating temperature.

5. Remove the replacement PC board and substitute it with the original PC board to recreate the original problem.

- a. If the original problem does not reappear by substituting the original board, then the PC board was not the problem. Continue to look for bad connections in the control wiring harness, junction blocks, and terminal strips.

- b. If the original problem is recreated by the substitution of the original board, then the PC board was the problem. Reinstall the replacement PC board and test the machine.

6. Always indicate that this procedure was followed when warranty reports are to be submitted.

**NOTE:** Following this procedure and writing on the warranty report, "INSTALLED AND SWITCHED PC BOARDS TO VERIFY PROBLEM," will help avoid denial of legitimate PC board warranty claims.

Observe Safety Guidelines detailed in the beginning of this manual.

PROBLEMS (SYMPTOMS)	POSSIBLE AREAS OF MISADJUSTMENT(S)	RECOMMENDED COURSE OF ACTION
<b>OUTPUT PROBLEMS</b>		
Major Physical or Electrical Damage is Evident.	Contact the Lincoln Electric Service Dept. 1-888-935-3877	
The Machine is dead. The Input contactor does not operate.	<ol style="list-style-type: none"> <li>1. Check for blown or missing fuses in input lines.</li> <li>2. Check the three- phase input line voltage at the machine. The input voltage must match the rating plate and reconnect panel.</li> </ol>	<ol style="list-style-type: none"> <li>1. The ON/OFF PUSH BUTTON (S1) may be faulty - Check for proper operation. See wiring diagram.</li> <li>2. The Control Transformer (T2) may be faulty. Perform the Control Transformer Test.</li> <li>3. The primary or secondary thermostats may be open. Check or replace. Also check the associated wiring. See wiring diagram.</li> <li>4. The pilot relay (CR2) may be faulty. Check or replace. See wiring diagram.</li> <li>5. The input contactor coil may be open. See wiring diagram.</li> <li>6. The Control board may be faulty. Replace.</li> </ol>

**⚠ CAUTION**

If for any reason you do not understand the test procedures or are unable to perform the tests/repairs safely, contact the Lincoln Electric Service Department for technical troubleshooting assistance before you proceed. Call 1-888-935-3877.

Return to Section TOC

Return to Master TOC

Return to Section TOC

Return to Master TOC

Return to Section TOC

Return to Master TOC

Return to Section TOC

Return to Master TOC



Observe Safety Guidelines detailed in the beginning of this manual.

PROBLEMS (SYMPTOMS)	POSSIBLE AREAS OF MISADJUSTMENT(S)	RECOMMENDED COURSE OF ACTION
<b>OUTPUT PROBLEMS</b>		
Input contactor (CR1) chatters.	<ol style="list-style-type: none"> <li>1. The input line voltage may be low. Check all three phases.</li> <li>2. Make sure input line voltage matches machine rating and the reconnect panel is connected correctly for the line voltage.</li> </ol>	<ol style="list-style-type: none"> <li>1. The pilot relay (CR2) may have bad contacts. Check or replace relay.</li> <li>2. Check for loose or faulty wiring between pilot relay (CR2) and input contactor (CR1) coil connections.</li> <li>3. The input contactor (CR1) may be faulty. Replace.</li> </ol>
Input contactor pulls in when start button is pressed but immediately drops out when start button is released.	<ol style="list-style-type: none"> <li>1. Make sure input line voltage matches machine rating and the reconnect panel is connected correctly for the line voltage.</li> <li>2. Remove all external wires attached to terminal strip. ( 2, 4, 31, 32 75,76,77). If contactor (CR1) functions correctly there may be a "ground" or negative intrusion on the remote control leads (75, 76, or 77). There may also be a "short" at the welder output terminals.</li> <li>3. If the problem persists after performing steps #1 and #2 the problem is in the DC600.</li> </ol>	<ol style="list-style-type: none"> <li>1. The CR1 interlock may be faulty. Replace if necessary.</li> <li>2. The ON/OFF PUSH BUTTON may be faulty. Check or replace.</li> <li>3. Check internal remote control circuit ( leads 75, 76 and 77) and switch SW3 for grounds or shorts.</li> <li>4. The control board may be faulty. Replace.</li> </ol>

**⚠ CAUTION**

If for any reason you do not understand the test procedures or are unable to perform the tests/repairs safely, contact the Lincoln Electric Service Department for technical troubleshooting assistance before you proceed. Call 1-888-935-3877.

IDEALARC® DC-600



Observe Safety Guidelines detailed in the beginning of this manual.

PROBLEMS (SYMPTOMS)	POSSIBLE AREAS OF MISADJUSTMENT(S)	RECOMMENDED COURSE OF ACTION
<b>OUTPUT PROBLEMS</b>		
<p>Machine input contactor operates but machine has no weld output. Fan runs and pilot light glows.</p>	<ol style="list-style-type: none"> <li>1. Install a jumper from #2 to #4 on machine terminal strip. If machine weld output is restored the problem is in the wire feeder or control cable.</li> <li>2. If remote control is not being used make certain the OUTPUT CONTROL SWITCH (SW3) is in the "OUTPUT CONTROL AT DC 600" position.</li> <li>3. Check 8AMP fuse in the front panel. Replace if blown.</li> <li>4. Check for loose or faulty weld cable connections.</li> </ol>	<ol style="list-style-type: none"> <li>1. Check operation of output pilot relay (CR4). There should be 115VAC present at leads #31 and #4 at (CR4) when #2 and #4 are jumpered together at the terminal strip.               <ol style="list-style-type: none"> <li>a. If the correct voltage is present and the relay does not activate, the relay may be faulty. -Replace.</li> <li>b. If the 115VAC is missing, check the associated wiring for loose or faulty connections. See wiring diagram.</li> </ol> </li> <li>2. Check the OUTPUT CONTROL POTENTIOMETER (R1) and associated circuitry for loose or faulty connections. See wiring diagram.</li> <li>3. Perform <b>Main Transformer Test.</b></li> <li>4. Perform <b>Firing Board Test.</b></li> <li>5. Perform <b>Control Board Test.</b></li> <li>6. Perform <b>SCR Output Bridge Test.</b></li> </ol>

**⚠ CAUTION**

If for any reason you do not understand the test procedures or are unable to perform the tests/repairs safely, contact the Lincoln Electric Service Department for technical troubleshooting assistance before you proceed. Call 1-888-935-3877.

IDEALARC® DC-600



Return to Section TOC

Return to Section TOC

Return to Section TOC

Return to Section TOC

Return to Master TOC

Return to Master TOC

Return to Master TOC

Return to Master TOC

Observe Safety Guidelines detailed in the beginning of this manual.

PROBLEMS (SYMPTOMS)	POSSIBLE AREAS OF MISADJUSTMENT(S)	RECOMMENDED COURSE OF ACTION
<b>OUTPUT PROBLEMS</b>		
<p>Machine has maximum weld output and no control.</p>	<p>1. If remote control is being used set OUTPUT CONTROL SWITCH (SW3) in "OUTPUT CONTROL AT DC600" position and control weld output with the OUTPUT CONTROL POTENTIOMETER (R1) at DC600. If the problem is solved check the remote control unit (or wire feeder) and associated control cable.</p>	<ol style="list-style-type: none"> <li>1. Check OUTPUT CONTROL SWITCH (SW3) and associated wiring.</li> <li>2. Check feedback leads #222 (negative output terminal), #215, and #210 (output shunt) for loose or faulty connections. See wiring diagram.</li> <li>3. Check the #75 lead for continuity (zero ohms) from the OUTPUT CONTROL POTENTIOMETER (R1) to the control board plug 2J1. See wiring diagram.</li> <li>4. Perform <b>Firing Board Test</b>.</li> <li>5. Perform <b>Control Board Test</b>.</li> <li>6. Perform <b>SCR Output Bridge Test</b>.</li> </ol>

**⚠ CAUTION**

If for any reason you do not understand the test procedures or are unable to perform the tests/repairs safely, contact the Lincoln Electric Service Department for technical troubleshooting assistance before you proceed. Call 1-888-935-3877.

Return to Section TOC

Return to Master TOC

Observe Safety Guidelines detailed in the beginning of this manual.

PROBLEMS (SYMPTOMS)	POSSIBLE AREAS OF MISADJUSTMENT(S)	RECOMMENDED COURSE OF ACTION
<b>OUTPUT PROBLEMS</b>		
Machine has minimum output and no control.	<ol style="list-style-type: none"> <li>1. If a remote control unit is NOT connected to the terminal strip #75, #76, and #77 terminals, the OUTPUT CONTROL SWITCH must be in the "OUTPUT CONTROL AT DC600" position.</li> <li>2. If a remote control cable is connected to terminals #75, #76 and #77 the leads may be "shorted" to the positive weld output.</li> <li>3. Make certain the Three Phase input voltage is correct and matches the machine rating and the reconnect panel.</li> </ol>	<ol style="list-style-type: none"> <li>1. Check the OUTPUT CONTROL POTENTIOMETER (R1) and associated wiring.</li> <li>2. Check the OUTPUT CONTROL SWITCH (SW3), the WELDING MODE SWITCH (SW4) and associated wiring.</li> <li>3. Perform the <b>Control Board Test</b>.</li> <li>4. Perform the <b>Firing Board Test</b>.</li> <li>5. Perform the <b>SCR Output Bridge Test</b>.</li> <li>6. Perform the <b>Main Transformer Test</b>.</li> </ol>
The machine does not have maximum weld output.	<ol style="list-style-type: none"> <li>1. Check all Three-Phase input lines at the DC600. Make sure input voltages match machine rating and reconnect panel.</li> <li>2. Put OUTPUT CONTROL SWITCH (SW3) in "OUTPUT CONTROL AT DC600" position. If problem is solved then check remote control unit or wire feeder.</li> </ol>	<ol style="list-style-type: none"> <li>1. Check the OUTPUT CONTROL POTENTIOMETER (R1) and associated wiring for loose or faulty connections. See wiring diagram.</li> <li>2. Perform <b>Control Board Test</b>.</li> <li>3. Perform <b>Firing Board Test</b>.</li> <li>4. Perform <b>Main Transformer Test</b>.</li> <li>5. Perform <b>SCR Output Bridge Test</b>.</li> </ol>

### ⚠ CAUTION

If for any reason you do not understand the test procedures or are unable to perform the tests/repairs safely, contact the Lincoln Electric Service Department for technical troubleshooting assistance before you proceed. Call 1-888-935-3877.

IDEALARC® DC-600



Observe Safety Guidelines detailed in the beginning of this manual.

PROBLEMS (SYMPTOMS)	POSSIBLE AREAS OF MISADJUSTMENT(S)	RECOMMENDED COURSE OF ACTION
<b>OUTPUT PROBLEMS</b>		
<p>Machine shuts off (input contactor drops out) when the welder output terminals are made electrically "hot". (#2 to #4 closure at terminal strip.)</p>	<ol style="list-style-type: none"> <li>1. Remove all welding cables and control cables from the DC 600. Jumper #2 to #4 at the terminal strip. If the machine does NOT shut off and normal open circuit voltage is present at the welder output terminals the problem is external to the DC600. Either the remote leads #75, #76 or #77 are grounded to the negative output cable or there is a short on the welding output terminals.</li> <li>2. If the machine still shuts off when all control and welding cables are removed then the problem is internal to the DC600.</li> </ol>	<ol style="list-style-type: none"> <li>1. Check for grounds and or shorts in the #75, #76, #77 circuit. See wiring diagram.</li> <li>2. Check for grounds and shorts in the welder output terminals and associated leads. See wiring diagram.</li> <li>3. Check the output shunt and associated leads. See wiring diagram.</li> <li>4. Perform the <b>Control Board Test</b>.</li> </ol>
<p>The DC600 will NOT shut off when the Stop button is pushed.</p>	<ol style="list-style-type: none"> <li>1. Contact your local Lincoln Authorized Field Service Facility.</li> </ol>	<ol style="list-style-type: none"> <li>1. The input contactor(CR1) contacts may be stuck closed. Check and replace if necessary.</li> <li>2. The Interlock contacts (Part of CR1) may be faulty. Replace if necessary.</li> <li>3. The ON/OFF PUSH BUTTON may be faulty. Check and replace if necessary.</li> </ol>

**⚠ CAUTION**

If for any reason you do not understand the test procedures or are unable to perform the tests/repairs safely, contact the Lincoln Electric Service Department for technical troubleshooting assistance before you proceed. Call 1-888-935-3877.

Return to Section TOC

Return to Section TOC

Return to Section TOC

Return to Section TOC

Return to Master TOC

Return to Master TOC

Return to Master TOC

Return to Master TOC

Observe Safety Guidelines detailed in the beginning of this manual.

PROBLEMS (SYMPTOMS)	POSSIBLE AREAS OF MISADJUSTMENT(S)	RECOMMENDED COURSE OF ACTION
<b>OUTPUT PROBLEMS</b>		
<p>The weld output terminals are always electrically "hot".</p>	<ol style="list-style-type: none"> <li>1. Remove any external leads hooked to #2 and #4 on the terminal strip. If the problem disappears the fault is in the control cable or wire feeder.</li> <li>2. If some open circuit voltage is present (over 3VDC.) after performing Step #1. then the problem is within the DC-600.</li> </ol>	<ol style="list-style-type: none"> <li>1. Check for an internal short between leads #2 and #4. See wiring diagram.</li> <li>2. The Pilot Relay (CR4) may be "stuck" closed. Check or replace.</li> <li>3. Perform <b>Firing Board Test</b>.</li> <li>4. Perform <b>Control Board Test</b>.</li> <li>5. Perform the <b>SCR Output Bridge Test</b>.</li> <li>6. The SCR Snubber(s) may be "leaky". Check or replace. See wiring diagram.</li> </ol>

**⚠ CAUTION**

If for any reason you do not understand the test procedures or are unable to perform the tests/repairs safely, contact the Lincoln Electric Service Department for technical troubleshooting assistance before you proceed. Call 1-888-935-3877.

Return to Section TOC

Return to Master TOC

Return to Section TOC

Return to Master TOC

Return to Section TOC

Return to Master TOC

Return to Section TOC

Return to Master TOC

Observe Safety Guidelines detailed in the beginning of this manual.

PROBLEMS (SYMPTOMS)	POSSIBLE AREAS OF MISADJUSTMENT(S)	RECOMMENDED COURSE OF ACTION
<b>OUTPUT PROBLEMS</b>		
<p>Poor arc starting when the DC600 is in the CV Sub-Arc or CV Innershield Modes.</p>	<ol style="list-style-type: none"> <li>1. Make sure the proper welding procedures are being used. (wire feed speed , arc voltage and wire size)</li>   <li>2. Check weld cables for loose or faulty connections.</li> </ol>	<ol style="list-style-type: none"> <li>1. Check the CR3 reed switch. The voltage from lead #215 to lead #220 should be 8VDC when the DC600 is in an idle condition (on but not welding). When the machine is producing welding current the reed switch (CR3) should close and the voltage from #215 to #220 should drop to zero.</li>   <li>2. Perform the <b>Firing Board Test</b>.</li>   <li>3. Perform the <b>SCR Output Bridge Test</b>.</li>   <li>4. The control board may be faulty. Replace.</li> </ol>

**⚠ CAUTION**

If for any reason you do not understand the test procedures or are unable to perform the tests/repairs safely, contact the Lincoln Electric Service Department for technical troubleshooting assistance before you proceed. Call 1-888-935-3877.

Return to Section TOC    Return to Section TOC    Return to Section TOC    Return to Section TOC    Return to Section TOC

Return to Master TOC    Return to Master TOC    Return to Master TOC    Return to Master TOC    Return to Master TOC

Observe Safety Guidelines detailed in the beginning of this manual.

PROBLEMS (SYMPTOMS)	POSSIBLE AREAS OF MISADJUSTMENT(S)	RECOMMENDED COURSE OF ACTION
<b>OUTPUT PROBLEMS</b>		
<p>Poor arc characteristics in all processes.</p>	<ol style="list-style-type: none"> <li>1. Check for the correct input voltages on the three- phase input lines at the DC600.</li> <li>2. Make sure the proper welding procedures are being used.(wire feed speed, arc voltage and wire size).</li> <li>3. Check the welding cables for loose or faulty connections.</li> </ol>	<ol style="list-style-type: none"> <li>1. Check the WELDING MODE SWITCH (SW4) and the associated wiring for loose or faulty connections. See wiring diagram.</li> <li>2. Check the CR3 reed switch. The voltage from lead #215 to lead #220 should be 8VDC when the DC600 is in an idle condition. When the machine is producing welding current the reed switch (CR3) should close and the voltage from #215 to #220 should drop to zero.</li> <li>3. Perform the <b>Firing Board Test</b>.</li> <li>4. Perform the <b>SCR Output Bridge Test</b>.</li> <li>5. The control board may be faulty. Replace.</li> </ol>

**⚠ CAUTION**

If for any reason you do not understand the test procedures or are unable to perform the tests/repairs safely, contact the Lincoln Electric Service Department for technical troubleshooting assistance before you proceed. Call 1-888-935-3877.

Return to Section TOC

Return to Master TOC



# TROUBLESHOOTING AND REPAIR

---

## CONTROL TRANSFORMER (T2) VOLTAGE TEST

### WARNING

Service and repair should be performed only by Lincoln Electric factory trained personnel. Unauthorized repairs performed on this equipment may result in danger to the technician or machine operator and will invalidate your factory warranty. For your safety and to avoid electrical shock, please observe all safety notes and precautions detailed throughout this manual.

If for any reason you do not understand the test procedures or are unable to perform the test/repairs safely, contact the Lincoln Electric Service Department for electrical troubleshooting assistance before you proceed. Call 1-888-935-3877.

---

### TEST DESCRIPTION

This test will determine if the correct voltage is being

- a. applied to the primary of the control transformer.
- b. induced on the secondary winding of the control transformer.

### MATERIALS NEEDED

Volt/Ohm Meter (Multimeter)

IDEALARC DC-600 wiring diagrams (See *Electrical Diagram Section* of Manual).

## CONTROL TRANSFORMER (T2) VOLTAGE TEST (continued)

FIGURE F.1 - Control Transformer and Lead Locations

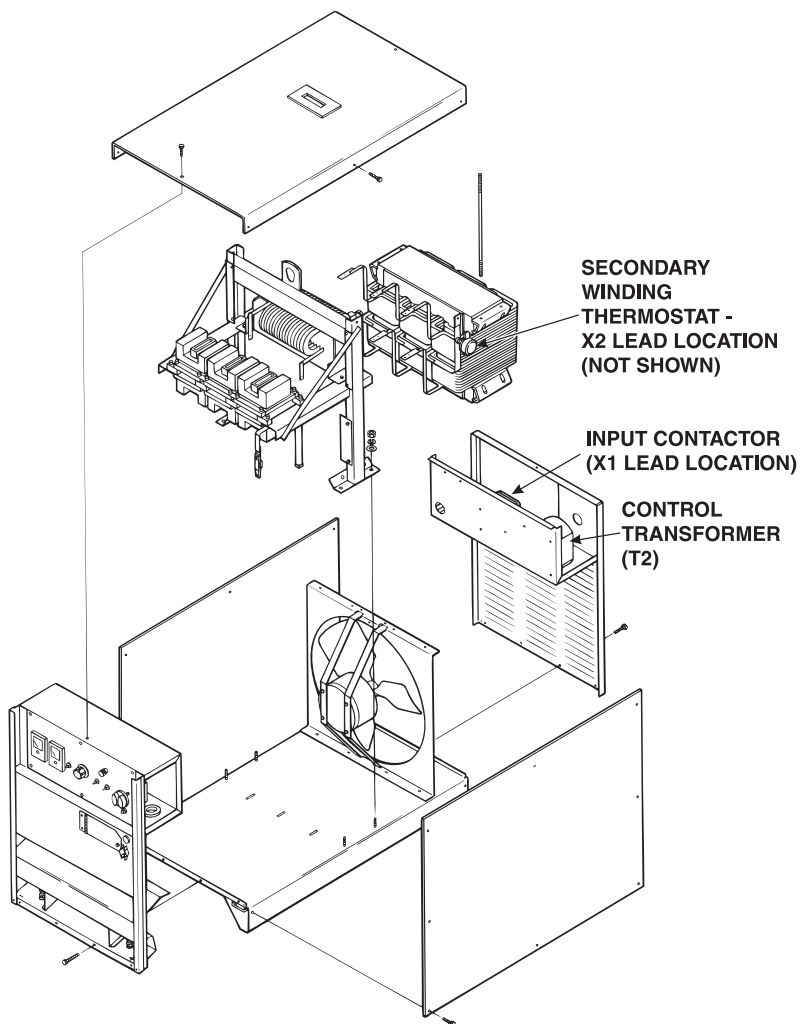

### PROCEDURE

1. Disconnect main AC input power to the machine.
2. Remove the Top and Case Sides.
3. Locate the Control Transformer (T2) on the left side of the Input Box (facing the back the of the machine). See Figure F.1.
4. Locate the Control Transformer primary leads (H1, H2, H3, etc.). See wiring diagram.
5. Locate Control Transformer leads X1 and X2.
  - a. Lead X1 is connected to the Input Contactor (CR1) interlock located underneath the Input Contactor. See Figure F.1.
  - b. Lead X2 is connected to the secondary winding thermostat. See Figure F.1.

NOTE: Unused leads should be taped.

- a. Inspect for broken or incorrect connections.

## CONTROL TRANSFORMER (T2) VOLTAGE TEST (continued) (continued)

FIGURE F.2 - Control Transformer X1 and X2 Test Connections

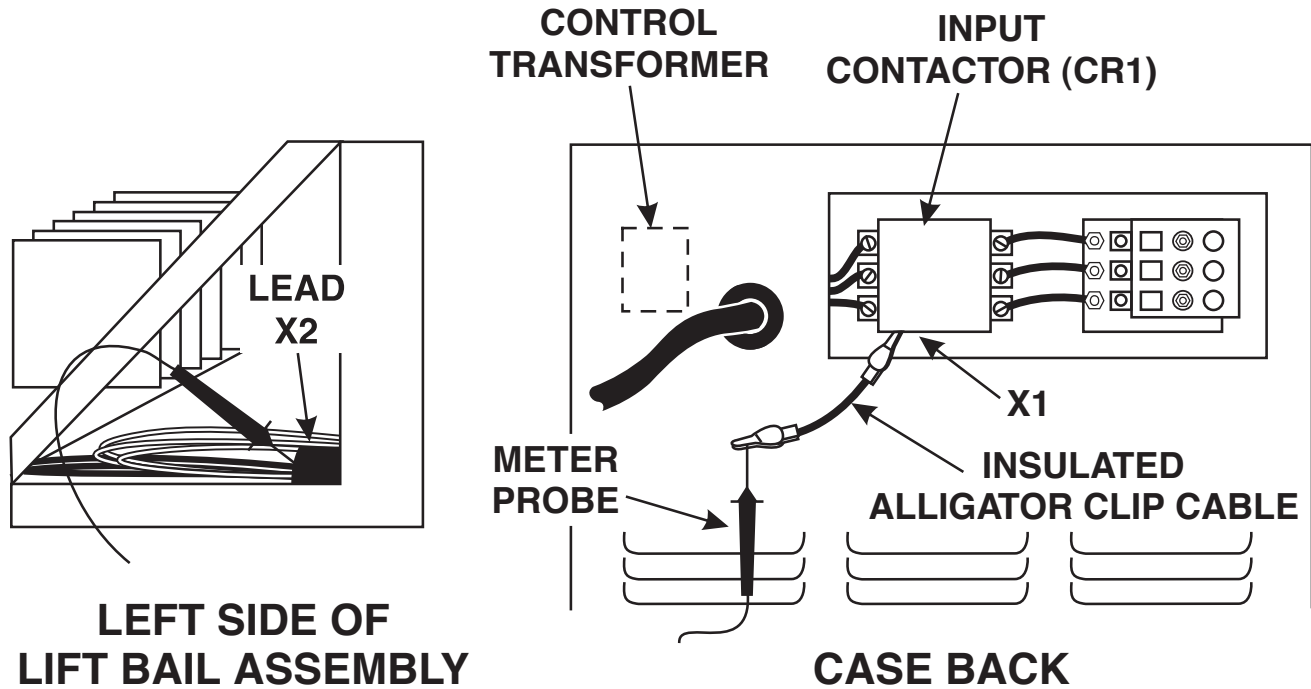

6. Test for 115 VAC between leads X1 and X2.

NOTE: If the main AC input supply voltage varies, the Control Transformer voltage will vary by the same percentage.

- a. Connect one end of an insulated alligator clip to the X1 connection at the Input Contactor (CR1) interlock. See Figure F.2.
- b. Connect the other end of the alligator clip to one of the meter probes. Be sure that neither the alligator clip nor the meter probe touches any metal surfaces.
- c. Connect the other meter probe to the X2 connection at the secondary winding thermostat. See Figure F.2.
- d. Apply current Input Power to DC-600.

7. Read meter for 115 VAC.

- a. If 115 VAC is present, the Control Transformer is functioning properly.
- b. If 115 VAC IS NOT present, go to Step 8.

8. If 115 VAC is not present between leads X1 and X2, test for correct main AC input power to the Control Transformer primary windings (H1, H2, H3, etc.) See Wiring Diagram.

- a. If the correct main AC input power to the Control Transformer primary windings is present AND the secondary voltage is not correct, the Control Transformer may be faulty. Replace.

Return to Section TOC  
Return to Section TOC  
Return to Section TOC  
Return to Section TOC  
Return to Master TOC  
Return to Master TOC  
Return to Master TOC  
Return to Master TOC

---

**MAIN TRANSFORMER (T1) VOLTAGE TEST****⚠ WARNING**

Service and repair should be performed only by Lincoln Electric factory trained personnel. Unauthorized repairs performed on this equipment may result in danger to the technician or machine operator and will invalidate your factory warranty. For your safety and to avoid electrical shock, please observe all safety notes and precautions detailed throughout this manual.

If for any reason you do not understand the test procedures or are unable to perform the test/repairs safely, contact the Lincoln Electric Service Department for electrical troubleshooting assistance before you proceed. Call 1-888-935-3877.

---

**TEST DESCRIPTION**

This test will determine if the correct voltages are being

- a. applied to the primary windings of the Main Transformer (T1).
- b. induced on the secondary winding, auxiliary windings, and phase angle windings.

**MATERIALS NEEDED**

Volt/Ohm Meter (Multimeter)

IDEALARC DC-600 wiring diagram (See *Electrical Diagram Section* of Manual).

## MAIN TRANSFORMER (T1) VOLTAGE TEST (continued)

FIGURE F.3 - Input Contactor, Reconnect Panel, and Primary Leads to Main Transformer Locations

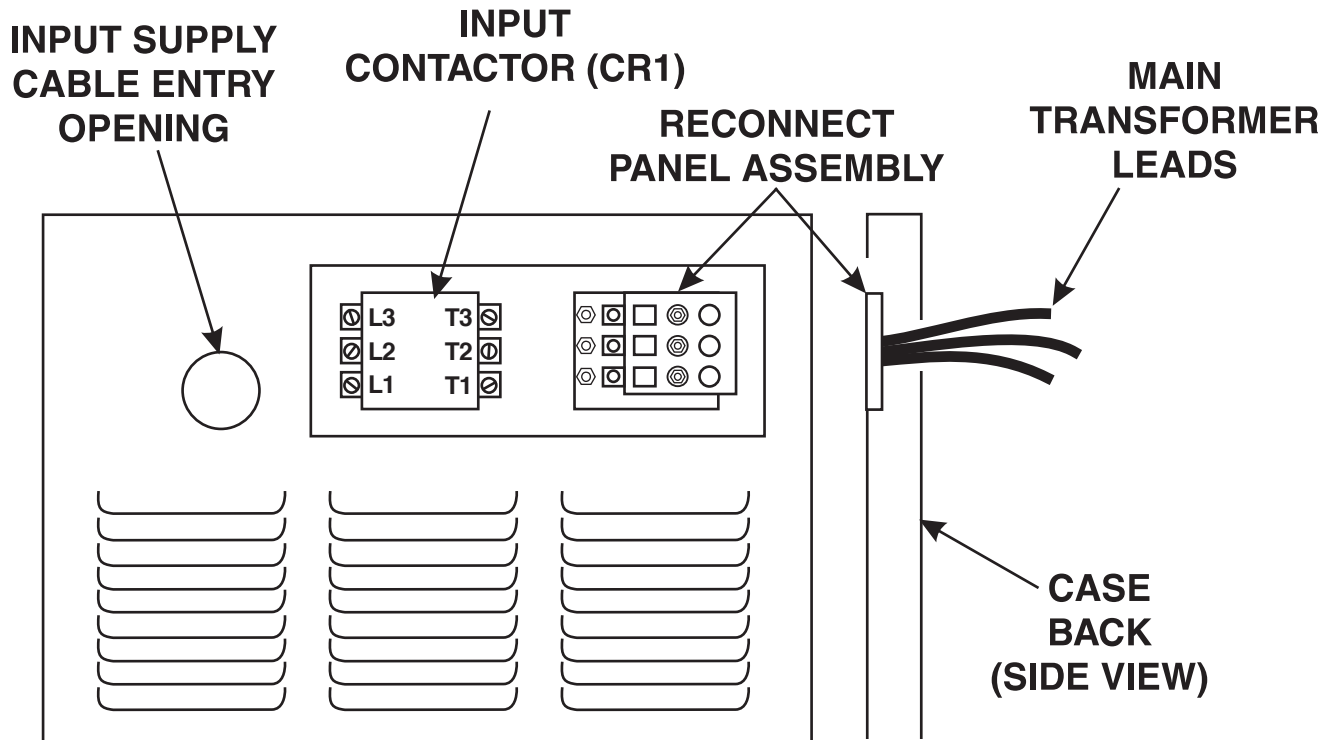

### PROCEDURE

1. Set ON/OFF PUSH BUTTON to OFF
2. Disconnect main AC input power from the machine.
3. Inspect the Input Contactor, Reconnect Panel, and primary leads to the Main Transformer for loose or faulty connections. See Figure F.3.
  - a. Confirm that the Reconnect Panel is connected properly for the three-phase main AC input power supplied to the machine. See the Reconnect Panel Connection Diagram located on the inside of the Input Box Assembly Access Door.
4. Connect main AC input power to the machine.
5. Set the ON/OFF PUSH BUTTON to ON.
  - a. Make sure the Input Contact (CR1) energizes. The fan runs.
6. Test with an AC voltmeter for proper main AC input voltage to the line side of the Input Contactor (CR1). See wiring diagram.
  - a. L1 to L2.
  - b. L2 to L3.
  - c. L1 to L3.

## MAIN TRANSFORMER (T1) VOLTAGE TEST (continued)

FIGURE F.4 - Main Secondary Lead Test Points

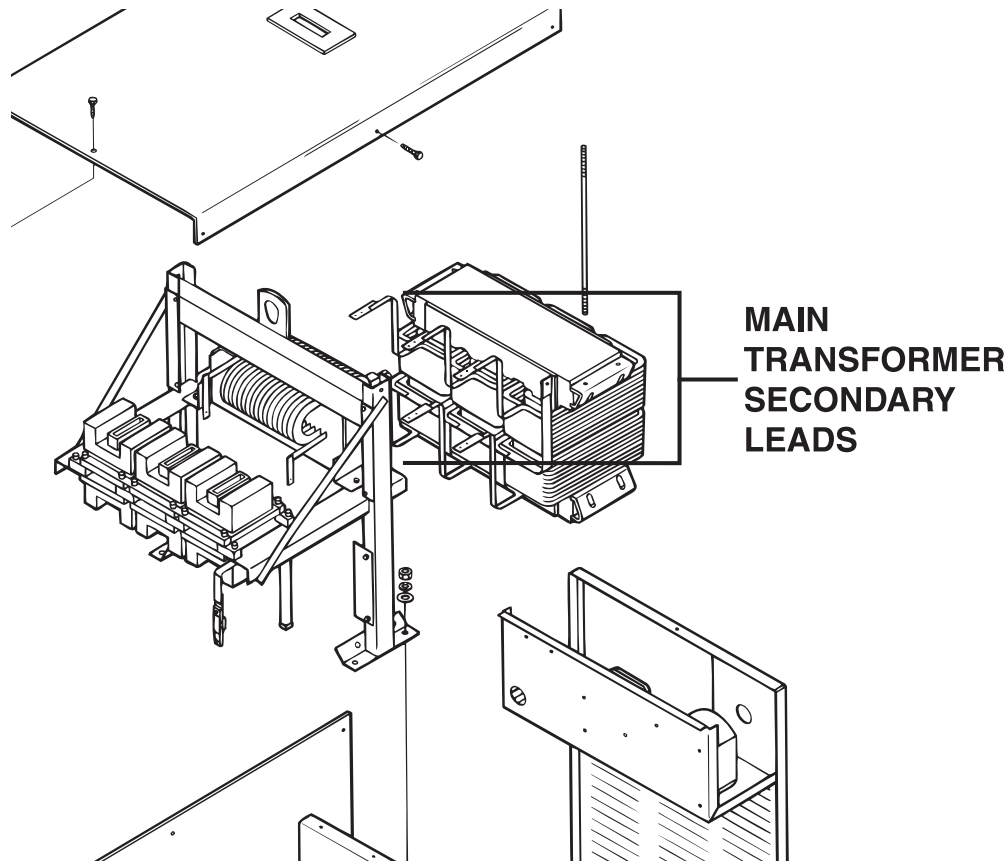

7. Read meter.
  - a. If proper voltage is present for all three phases, proper main AC input voltage is being supplied.
  - b. If proper voltage is not present in any or all of the three phases, check input fuses and leads.
8. Test with an AC voltmeter for proper main AC input voltage from the output side of the Input Contactor (CR1). See wiring diagram.
  - a. T1 to T2.
  - b. T2 to T3.
  - c. T1 to T3.
9. Read meter.
  - a. If proper voltage is present for all three phases, the Contactor is working properly.
  - b. If the proper voltage is not present for any or all of the three phases, the contactor may be faulty. Replace.
10. Test with an AC voltmeter for 52 VAC from each of the six main transformer secondary leads to the common buss connected to the output choke. See Figure F.4.
  - a. If one or more of the above voltage tests are incorrect, check for loose or faulty wiring.
  - b. If the wiring is good, then the Main Transformer may be faulty. Replace.







Return to Section TOC

Return to Section TOC

Return to Section TOC

Return to Section TOC

Return to Master TOC

Return to Master TOC

Return to Master TOC

Return to Master TOC

IDEALARC® DC-600



## FIRING BOARD TEST

**⚠ WARNING**

Service and repair should be performed only by Lincoln Electric factory trained personnel. Unauthorized repairs performed on this equipment may result in danger to the technician or machine operator and will invalidate your factory warranty. For your safety and to avoid electrical shock, please observe all safety notes and precautions detailed throughout this manual.

If for any reason you do not understand the test procedures or are unable to perform the test/repairs safely, contact the Lincoln Electric Service Department for electrical troubleshooting assistance before you proceed. Call 1-888-935-3877.

**TEST DESCRIPTION**

This test determines whether or not the Firing Board is receiving the correct voltages and gate signals. The LEDs (Light Emitting Diodes) will help you determine if the Firing Board is generating gate signals to the main SCRs.

**MATERIALS NEEDED**

Volt/Ohm Meter (Multimeter)

IDEALARC DC-600 wiring diagram and Firing Board schematic drawing (See **Electrical Drawing Section** of Manual).

## FIRING BOARD TEST (continued)

## TEST PROCEDURE FOR NORMAL FIRING BOARD OPERATION

1. Disconnect main AC input power to the IDEALARC DC-600.
2. Locate the Firing Board on the left side of Control Box facing the machine.
3. Perform a visual inspection of the Firing Board to see if there are any loose or faulty connections.
4. Connect the correct main AC input power to the machine.
5. Set the ON/OFF PUSH BUTTON to ON.
6. Locate LEDs 7, 8, and 9 on the Firing Board. See **Figure F.7**. Each LED should be ON and be equally bright. Use **Table F.1** to check the operation of each LED.

Return to Section TOC  
Return to Master TOCReturn to Section TOC  
Return to Master TOCReturn to Section TOC  
Return to Master TOCReturn to Section TOC  
Return to Master TOC

## FIRING BOARD TEST (continued)

FIGURE F.7 - Firing Board LED and Molex Plug Locations

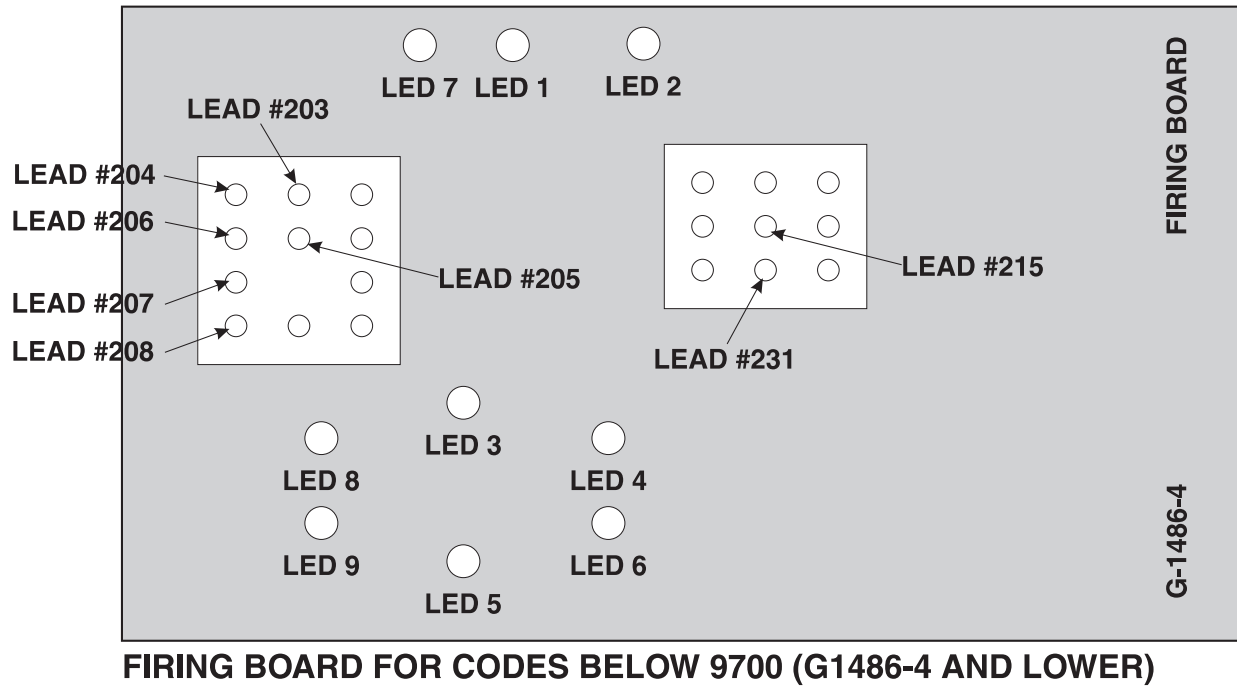
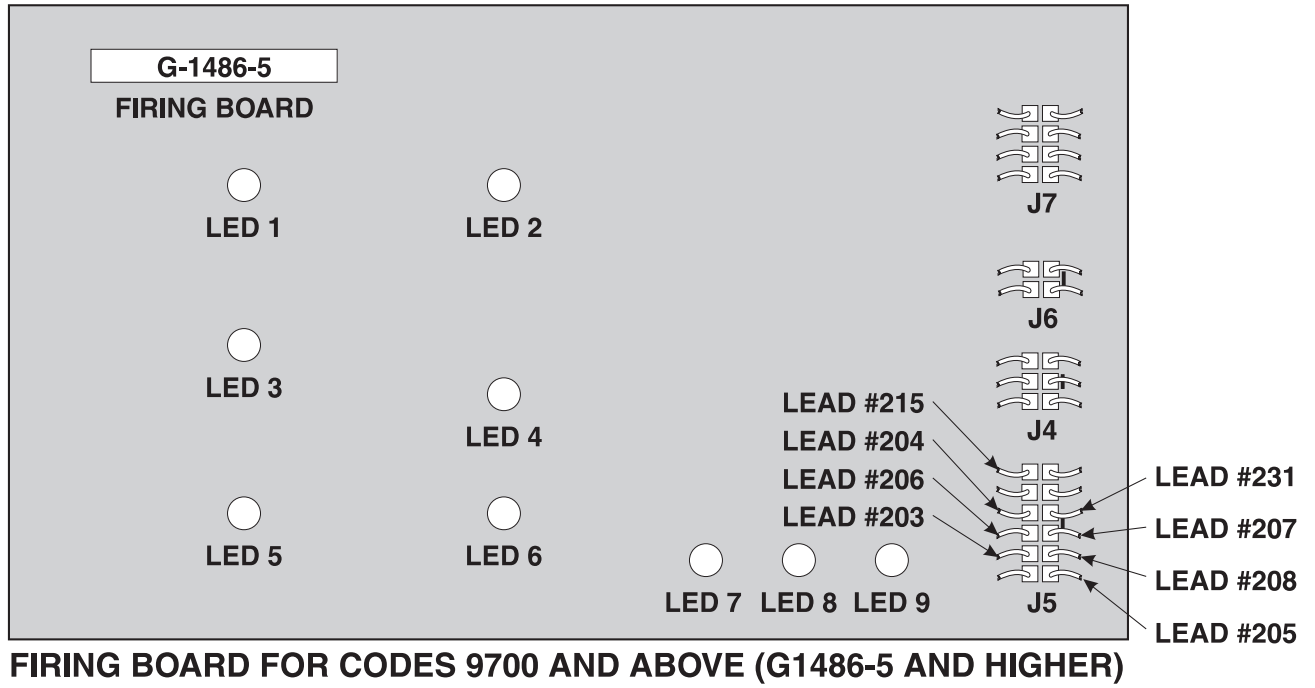

Return to Section TOC

Return to Section TOC

Return to Section TOC

Return to Section TOC

Return to Master TOC

Return to Master TOC

Return to Master TOC

Return to Master TOC

## FIRING BOARD TEST (continued)

TABLE F.1 - LED 7, 8 and 9 Check List

IF	THEN
LED 7 is ON	AC power is being supplied to the Firing Board from leads #203 and #204 connected to the phase angle winding in the Main Transformer.
LED 7 is OFF or is DIMMER than other LEDs	The proper AC voltage may not be reaching Firing Board. Check for loose or faulty connections. <b>Perform Main Transformer Test.</b>
LED 8 is ON	AC power is being supplied to the Firing Board from leads #205 and #206 connected to the phase angle winding in the Main Transformer.
LED 8 is OFF or is DIMMER than other LEDs	The proper AC voltage may not be reaching Firing Board. Check for loose or faulty connections. <b>Perform Main Transformer Test.</b>
LED 9 is ON	AC power is being supplied to the Firing Board from leads #207 and #208 connected to the phase angle winding in the Main Transformer.
LED 9 is OFF or is DIMMER than other LEDs	The proper AC voltage may not be reaching Firing Board. Check for loose or faulty connections. <b>Perform Main Transformer Test.</b>

## FIRING BOARD TEST (continued)

FIGURE F.8 - Jumper Wire Connection Points

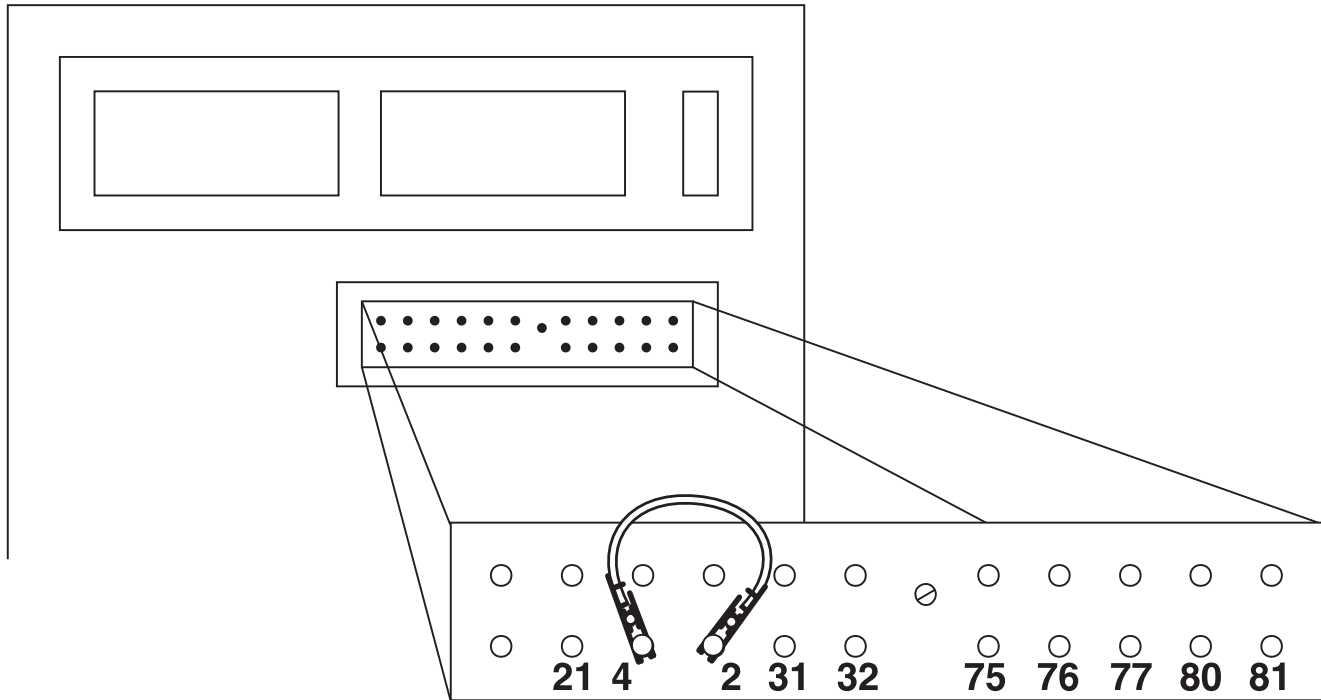

7. Locate the terminal strip directly below the Control Box.
8. Connect a jumper wire from terminal #2 to terminal #4 on the terminal strip. See Figure F.8.

NOTE: This jumper connection initiates machine output.

## FIRING BOARD TEST (continued)

9. Locate LEDs 1 to 6. Each LED should glow with equal brightness.  
NOTE: LEDs 1 to 6 indicate that the gate firing signals are being generated to send to each of the SCRs.
10. Set the OUTPUT CONTROL SWITCH (SW3) in the "Output Control at DC-600" position.
11. Set the WELDING CONTROL SWITCH in either of the "CV" positions.
12. Rotate the OUTPUT CONTROL POTENTIOMETER. As the pot is turned clockwise, the LEDs glow brighter. As the pot is turned counter-clockwise, the LEDs dim.
- If the LEDs glow and change in brightness equally as the pot is turned and the problem continues, then the SCR Bridge may be faulty. Perform **SCR Bridge test**.
  - If all of LEDs 1-6 do not glow or do not change in brightness equally as the pot is turned, go to Step 13.
  - One or two lights stay bright or dim and the others change, this could indicate an open or shorted gate lead or bad snubber board on related SCR assembly. Perform **SCR Bridge Test**.
13. Test for 10 VDC to 13 VDC between leads #231 and #215 on the Firing Board in CV mode.
- Locate on the Firing Board the Molex Plug with leads #231 and #215 connected to it. See **Figure F.7**.
  - Set the ON/OFF PUSH BUTTON to OFF.
  - Remove the Molex Plug from the board.
  - Insert the meter probes into the appropriate Plug lead cavities.
- NOTE: OBSERVE POLARITY. DC VOLTAGES BEING TESTED.
- Connect the Molex Plug into the Firing Board.
  - Set the WELDING MODE SWITCH in either of the "CV" positions.
  - Set the ON/OFF PUSH BUTTON to ON.
  - Rotate the OUTPUT CONTROL POTENTIOMETER clockwise and counter-clockwise. The DC voltage between leads #231 and #215 should vary from 10 VDC to 13 VDC as the pot is turned from minimum to maximum.
  - If the voltage does NOT vary, then the Control Board may be faulty. Replace.

Return to Section TOC  
Return to Master TOCReturn to Section TOC  
Return to Master TOCReturn to Section TOC  
Return to Master TOCReturn to Section TOC  
Return to Master TOC



## FIRING BOARD TEST (continued)

14. Test for approximately 5.8 VDC between leads #231 and # 215 on the Firing Board in VV (CC) mode.
  - a. Keep the meter probes inserted into the Plug lead cavities for leads #231 and #215.
  - b. Keep the jumper connected at terminals #2 and #4 at the terminal strip.
  - c. Set the WELDING MODE SWITCH (SW4) to the VV (CC) position.
  - d. Rotate the OUTPUT CONTROL POTENTIOMETER clockwise and counter-clockwise. The DC voltage between leads #231 and #215 should be constant at approximately 5.8 VDC. This voltage should not vary when the pot is turned.
  - e. Remove probes inserted into the Molex Plug lead cavities of lead #231 and #215.
15. Test Output Pilot Control Relay (CR4) for proper operation by removing and replacing repeatedly the jumper wire from terminal # 2. This should cause the relay contacts to open and close. The contacts can be seen closing and opening through the clear plastic relay case or can be heard opening and closing.
  - a. If the Output Control Relay (CR4) does not close when energized, check for loose or faulty wiring.
16. Remove the jumper from terminals #2 and #4 on the terminal strip.
17. Replace the Firing Board if the above voltage and control relay tests were passed. It may be faulty.

Return to Section TOC      Return to Section TOC      Return to Section TOC  
Return to Master TOC      Return to Master TOC      Return to Master TOC

---

**CONTROL BOARD TEST****⚠ WARNING**

Service and repair should be performed only by Lincoln Electric factory trained personnel. Unauthorized repairs performed on this equipment may result in danger to the technician or machine operator and will invalidate your factory warranty. For your safety and to avoid electrical shock, please observe all safety notes and precautions detailed throughout this manual.

If for any reason you do not understand the test procedures or are unable to perform the test/repairs safely, contact the Lincoln Electric Service Department for electrical troubleshooting assistance before you proceed. Call 1-888-935-3877.

---

**TEST DESCRIPTION**

This test will determine if the Control Board is receiving the correct voltages and feedback signals.

**MATERIALS NEEDED**

Analog Volt/Ohm Meter (Multimeter)  
IDEALARC DC-600 wiring diagrams (See *Electrical Diagrams Section* of this Manual).

Return to Section TOC

Return to Master TOC

Return to Section TOC

Return to Master TOC

Return to Section TOC

Return to Master TOC

Return to Section TOC

Return to Master TOC

**CONTROL BOARD TEST (continued)**

**FIGURE F.9 - Control Board LED Locations**

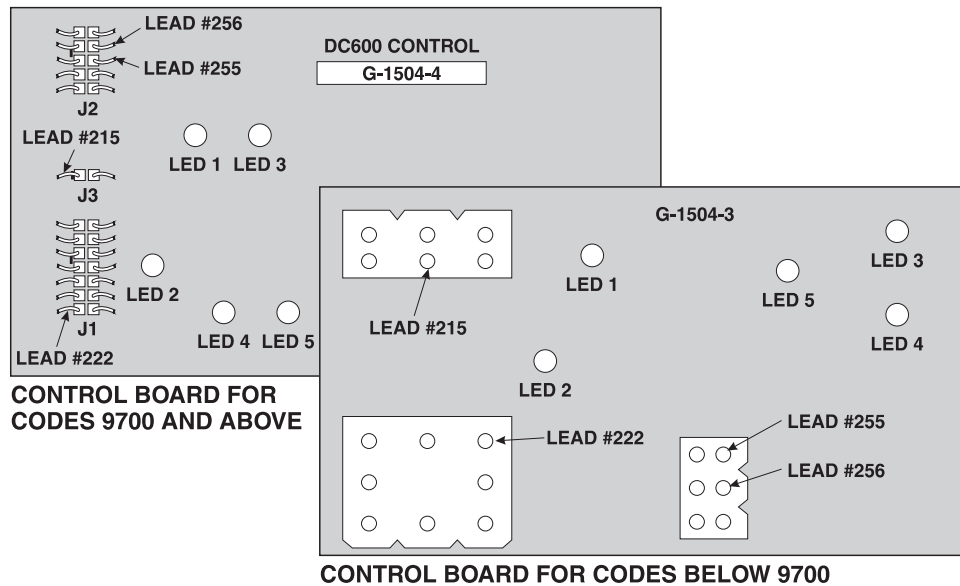

**TABLE F.2 - LED Function During Normal Operation**

LED #	FUNCTION DURING NORMAL OPERATION (Machine is ON)
1	Glows to display that 115 VAC is present between leads #255 and #256 at Plug J2 on Control Board.
2	Glows to display that output voltage feedback is being supplied to the Control Board. Terminals #2 and #4 on the terminal strip must be jumped together.
3	Glows to display that power is applied to fault protection relay (CR2).
4	DOES NOT GLOW. Glows only if there is a fault condition.
5	Glows to display a control signal (lead # 231) is being supplied to the Firing Circuit. When the OUTPUT CONTROL SWITCH (SW-3) is in the "Output Control at DC-600" position and the WELDING MODE SWITCH (SW-4) is in the "CV" position, the LED will glow brighter or dimmer as the OUTPUT CONTROL POTENTIOMETER is rotated. If the pot is rotated clockwise (open circuit voltage increased), the LED will glow dimmer. If the pot is rotated counter-clockwise (open circuit voltage decreased), the LED will glow brighter. When the WELDING MODE SWITCH (SW-4) is in the VV(CC) position for stick welding, the open circuit voltage is at maximum. LED 5 will be very dim or not lit.

Return to Section TOC

Return to Section TOC

Return to Section TOC

Return to Master TOC

Return to Master TOC

Return to Master TOC

## CONTROL BOARD TEST (continued)

FIGURE F.10 - LED 1 Test Points

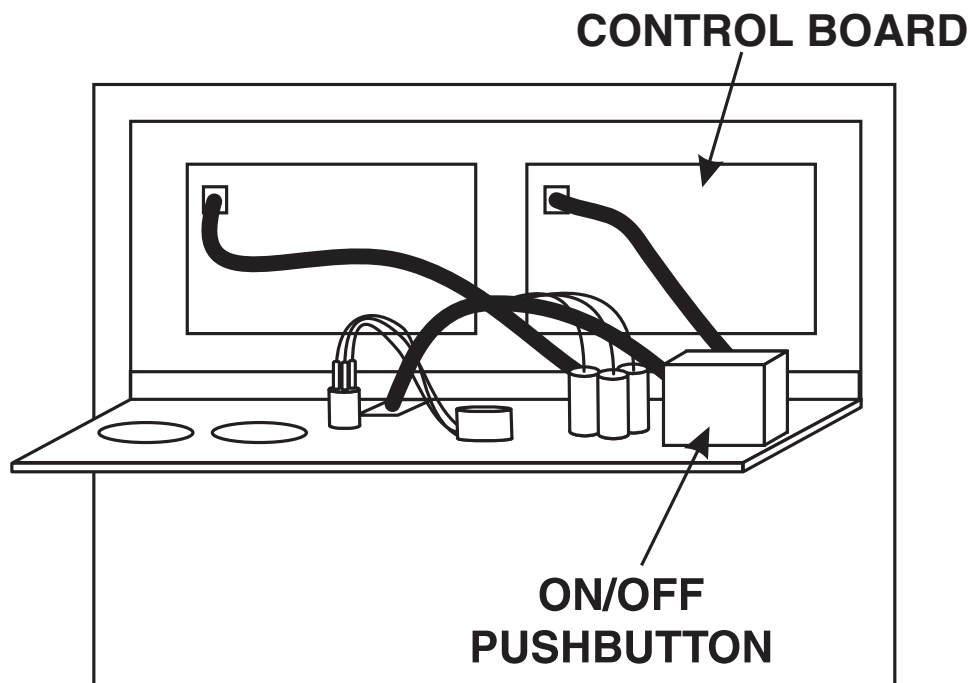

**If LED 1 Does Not Glow When ON/OFF PUSH BUTTON is Set to ON**

1. Test for 115 VAC between leads #255 and #256 at Plug J2 on the Control Board.
  - a. Disconnect main AC input supply power to the machine.
  - b. Locate the Control Board in the Control Box.
  - c. Disconnect Molex Plug J2.
  - d. Insert the probes into the Plug lead cavities for leads #255 and #256.
  - e. Replace the Molex Plug J2.
  - f. Connect main AC input power to the machine.
  - g. Set the ON/OFF PUSH BUTTON to ON.
  - h. Read meter for 115 VAC.

If 115 VAC is present AND LED 1 does not glow, the Control Board may be faulty. Replace.

If 115 VAC is not present,

- Inspect leads #255 and #256 and associated wiring for loose or faulty connections. See wiring diagram.
- Test for continuity (zero ohms) between lead # 256 at Plug J2 on the Control Board and the ON/OFF PUSH BUTTON. See Figure F.10.

NOTE: Disconnect main AC input power to the machine

- Test for continuity (zero ohms) between lead #256 at Plug J2 on the Control Board and lead X2 at the secondary thermostat. See Figure F.10.

NOTE: Disconnect main AC input power to the machine.

## CONTROL BOARD TEST (continued)

FIGURE F.11 - LED 2 Open Circuit Voltage Test Points

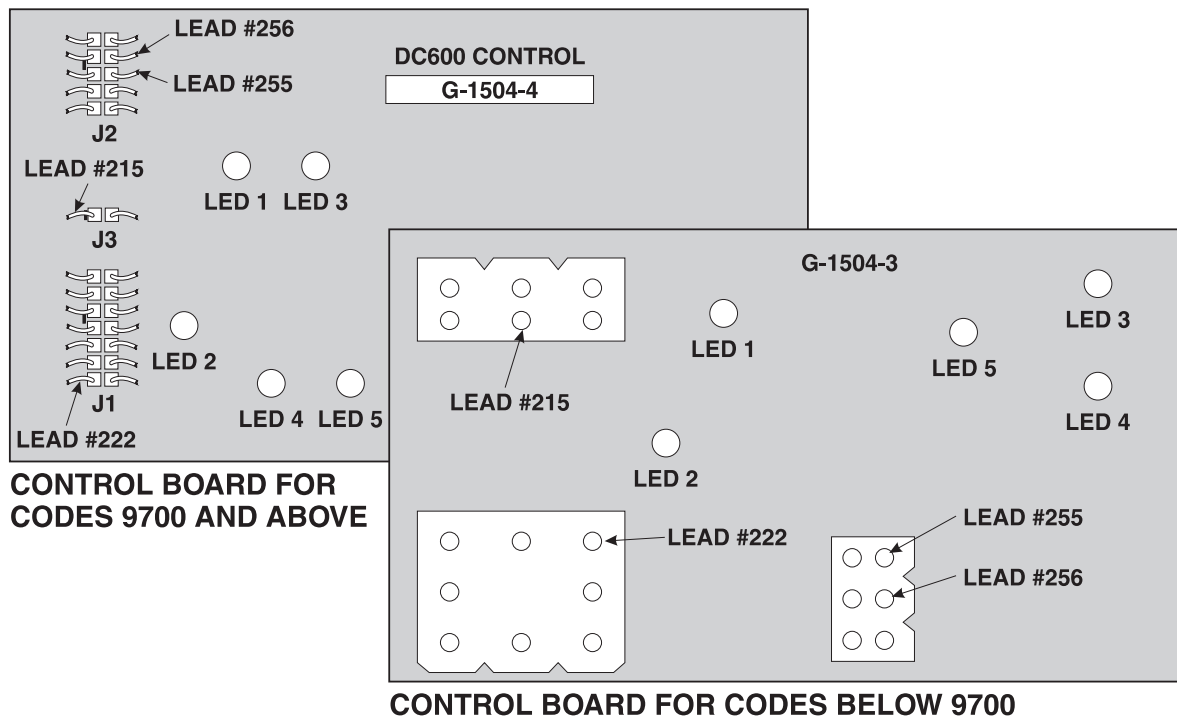

**If LED 2 Does Not Light When Machine is Operating Under Load (or terminals #2 and #4 are jumpered together on the terminal strip).**

1. Test for the following open circuit voltages at the Weld Output Terminals

- 15 - 58 VDC when the WELDING MODE SWITCH is in either of the CV positions
- 75 VDC when the WELDING MODE SWITCH is in the VV(CC) position.

NOTE: BE SURE TO OBSERVE POLARITY. DC VOLTAGES BEING TESTED.

2. Touch the negative (-) meter probe to the negative (-) Weld Output Terminal and positive (+) meter probe to the positive (+) Weld Output Terminal.

3. Read meter.

- a. If the open circuit voltage is present at the Weld Output Terminals, then test for open circuit voltage the Control Board.

- b. If the open circuit voltage is not present at the Weld Output Terminals, then

- Check the Output Choke and associated heavy current carrying leads for loose or faulty connections.

- Perform the Main Transformer Test

- Perform the Firing Board Test

- Perform the SCR Output Bridge Test

4. Test for open circuit voltage at the Control Board

- a. Insert meter probes in to Plug lead cavities to test for open circuit voltage from lead #222 at Plug J1 on the Control Board to lead #215 at Plug J3 on the Control Board. See Figure F.11.

## CONTROL BOARD TEST (continued)

- b. If the open circuit voltage is not present at the Control Board, then check leads #222 and #215 for loose or faulty wiring connections. See wiring diagram.
5. Test for continuity (zero ohms) between the negative output terminal and lead #222 at Plug J1 on the Control Board.
- a. If more than zero ohms is measured, the lead may be faulty.
6. Test for continuity (zero ohms) between the positive output terminal and lead #215 at Plug J3 on the Control Board.
- a. If more than zero ohms is measured, the lead may be faulty.

NOTE: If previous tests do not reveal the problem then the Control Board may be faulty. Replace.

**If LED 3 Does Not Glow But LED 1 Does Glow When ON PUSH BUTTON Is Pushed**

NOTE: When this condition occurs, the Fault Protection Relay (CR2) is not receiving the 24 VDC supply voltage. Therefore, the Input Contactor (CR1) cannot close. Perform the following:

1. Set and hold in the ON position the ON/OFF PUSH BUTTON.
- a. If LED 4 glows or flickers,
- Check the Weld Output Terminals and associated wiring for a "short" condition. See wiring diagram.
  - Check the Remote Control Circuit (leads #75, #76, #77). They may be shorted to the negative welding voltage. See wiring diagram.
- b. If the above procedures do not uncover the problem, the Control Board may be faulty. Replace.

**If LED 5 Does Not Glow and Vary in Brightness Under the Following Conditions**

Machine is operating under load (or terminals #2 and #4 are jumpered together on the terminal strip).

The OUTPUT CONTROL POTENTIOMETER is rotated.

The WELD MODE SWITCH is in either CV position.

The OUTPUT CONTROL SWITCH is in the "Output Control at DC-600" position.

1. Check the OUTPUT CONTROL POTENTIOMETER and associated wiring for loose or faulty connections.
- a. If all the above conditions are met, the Control Board may be faulty. Replace.

Return to Section TOC      Return to Section TOC      Return to Section TOC  
Return to Master TOC      Return to Master TOC      Return to Master TOC



## STATIC SCR TEST

**⚠ WARNING**

Service and repair should be performed only by Lincoln Electric factory trained personnel. Unauthorized repairs performed on this equipment may result in danger to the technician or machine operator and will invalidate your factory warranty. For your safety and to avoid electrical shock, please observe all safety notes and precautions detailed throughout this manual.

If for any reason you do not understand the test procedures or are unable to perform the test/repairs safely, contact the Lincoln Electric Service Department for electrical troubleshooting assistance before you proceed. Call 1-888-935-3877.

**TEST DESCRIPTION**

The Static SCR Test is used to quickly determine if an SCR is shorted or "leaky." See the Waveform Section in this manual for normal and abnormal SCR waveforms.

**MATERIALS NEEDED**

Analog Ohmmeter (Multimeter)  
IDEALARC DC-600 wiring diagrams (See *Electrical Diagrams Section* of this Manual).

Return to Section TOC

Return to Master TOC

Return to Section TOC

Return to Master TOC

Return to Section TOC

Return to Master TOC

Return to Section TOC

Return to Master TOC

## STATIC SCR TEST (continued)

### PROCEDURE

1. Disconnect main AC input power to the machine.
2. Disconnect all Molex Plugs from the Firing Board and Control Board. See Figure F.12.

**FIGURE F.12 - Firing Board and Control Board Molex Plug Locations**

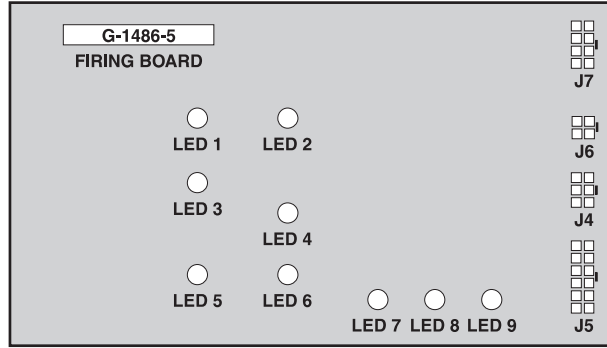

FIRING BOARD FOR CODES 9700 AND ABOVE

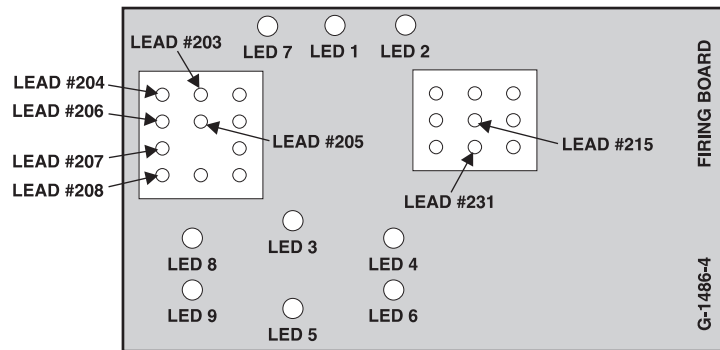

FIRING BOARD FOR CODES BELOW 9700

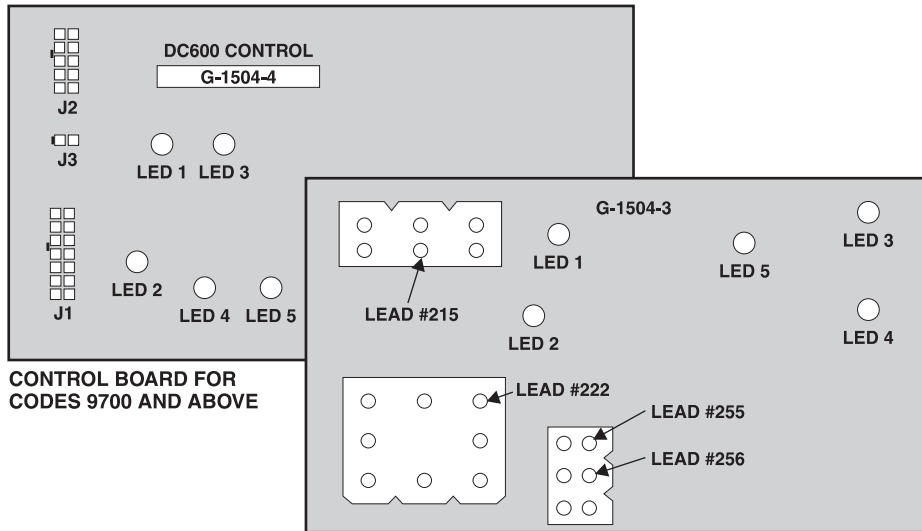

CONTROL BOARD FOR CODES 9700 AND ABOVE

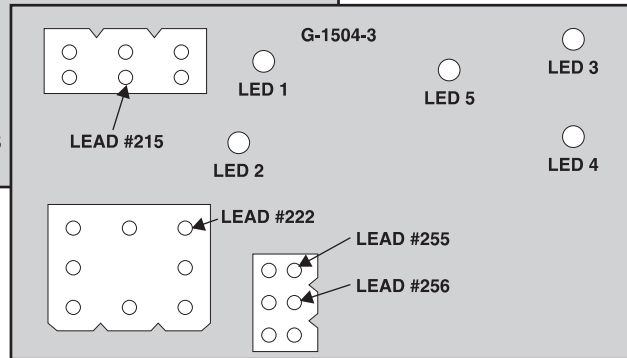

CONTROL BOARD FOR CODES BELOW 9700

Return to Section TOC

Return to Section TOC

Return to Section TOC

Return to Section TOC

Return to Master TOC

Return to Master TOC

Return to Master TOC

Return to Master TOC

## STATIC SCR TEST (continued)

FIGURE F.13 - Heat Sink Test Points

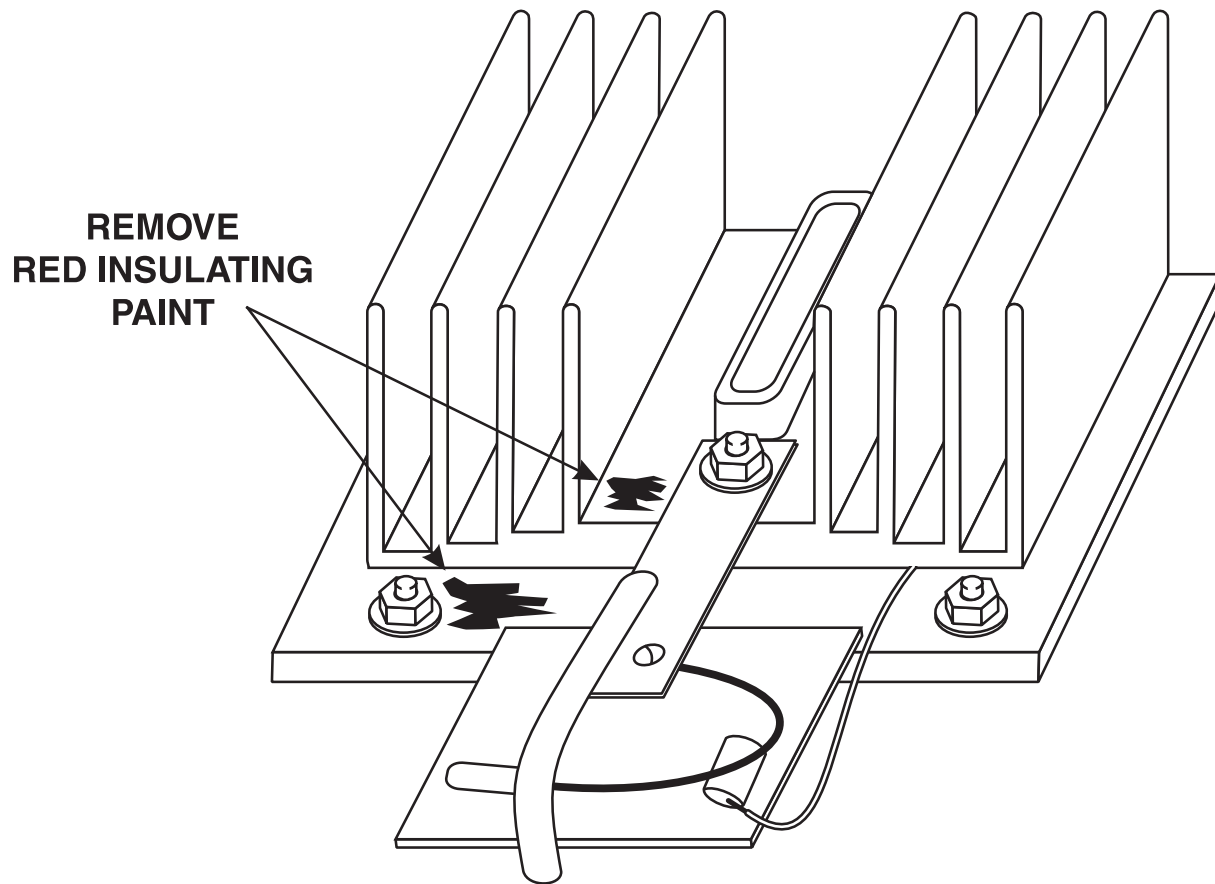

3. Remove the red insulating paint from the heat sink test points. See FIGURE F.13.
4. Test for high or infinite resistance from the anode to the cathode of SCR 1. **See Figure F.14.** Use an analog ohmmeter (Multimeter).

NOTE: DO NOT DISASSEMBLE THE HEAT SINKS.

## STATIC SCR TEST (continued)

FIGURE F.14 - SCR 1 Test Points

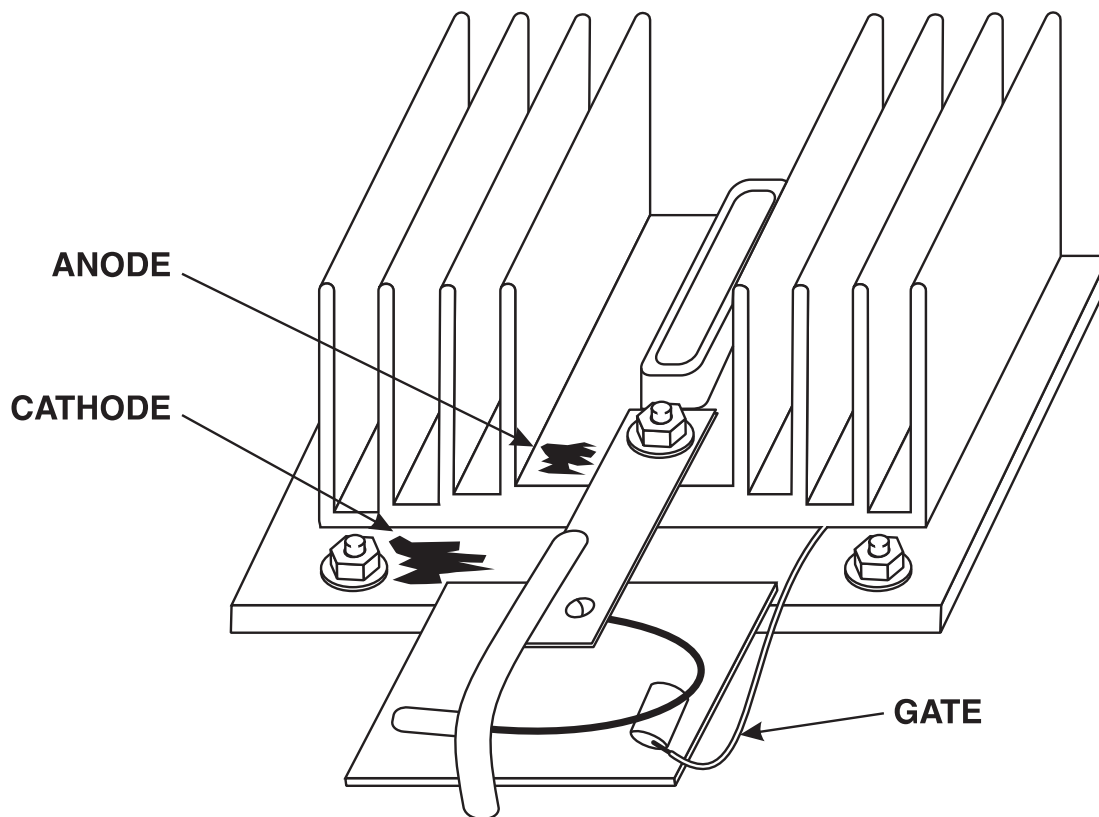

5. Test for high or infinite resistance from the cathode to the anode of SCR 1 by reversing the leads. See Figure F.14.
  - a. If a high or infinite resistance is indicated for both tests 4 and 5, the SCR 1 is not shorted.
  - b. If a low resistance is indicated in either strips 4 or 5, go to Step 6.
6. Disconnect the snubber circuit. See wiring diagram.
7. Retest SCR 1 with the snubber circuit disconnected.
  - a. If a low resistance is still indicated, SCR 1 is faulty. Replace. If one SCR is shorted they may all appear shorted. The SCRs will have to be tested separately by disconnecting the secondary leads from the bridge assembly.
  - b. If a very high or infinite resistance is indicated with the snubber circuit disconnected, replace the snubber circuit.
8. Repeat Steps 3 to 7 for SCRs 2 - 6.
9. Replace all Molex Plugs on the Firing Board and Control Board.

NOTE: To further check the SCR's Function, use an SCR tester and proceed to active SCR Test.

---

**ACTIVE SCR TEST****⚠ WARNING**

Service and repair should be performed only by Lincoln Electric factory trained personnel. Unauthorized repairs performed on this equipment may result in danger to the technician or machine operator and will invalidate your factory warranty. For your safety and to avoid electrical shock, please observe all safety notes and precautions detailed throughout this manual.

If for any reason you do not understand the test procedures or are unable to perform the test/repairs safely, contact the Lincoln Electric Service Department for electrical troubleshooting assistance before you proceed. Call 1-888-935-3877.

---

**TEST DESCRIPTION**

The Active SCR Test will determine if the device is able to be gated ON and conduct current from anode to cathode.

**MATERIALS NEEDED**

An SCR Tester as specified in this procedure.  
IDEALARC DC-600 wiring diagrams (See *Electrical Diagrams Section* of this Manual).

Return to Section TOC

Return to Section TOC

Return to Section TOC

Return to Section TOC

Return to Master TOC

Return to Master TOC

Return to Master TOC

Return to Master TOC

## ACTIVE SCR TEST (continued)

### PROCEDURE

1. Disconnect main AC input power to the machine.
2. Disconnect all Molex Plugs from the Firing Board and Control Board. See Figure F.15.

**FIGURE F.15 - Firing Board and Control Board Molex Plug Locations**

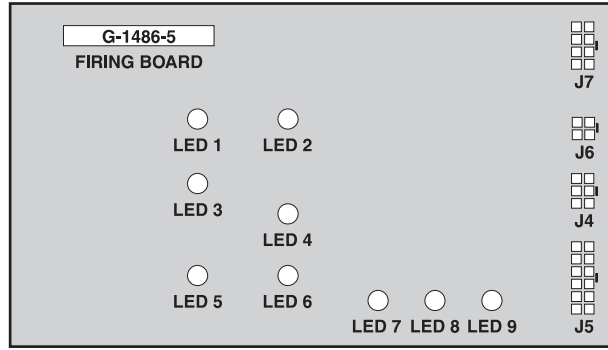

FIRING BOARD FOR CODES 9700 AND ABOVE

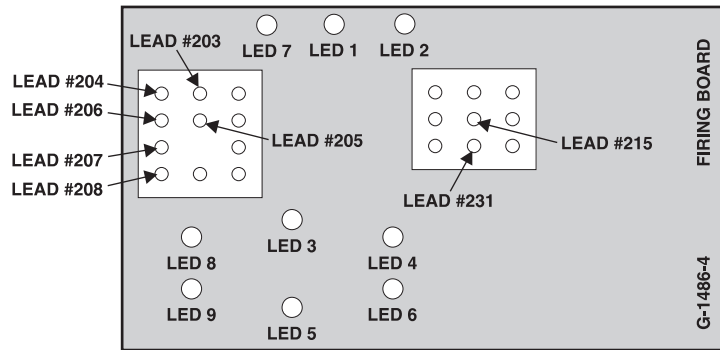

FIRING BOARD FOR CODES BELOW 9700

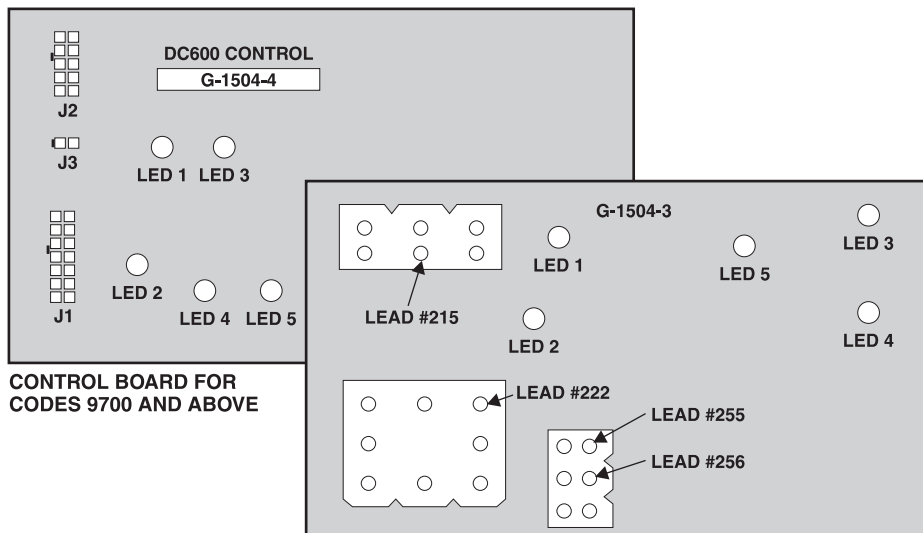

CONTROL BOARD FOR CODES 9700 AND ABOVE

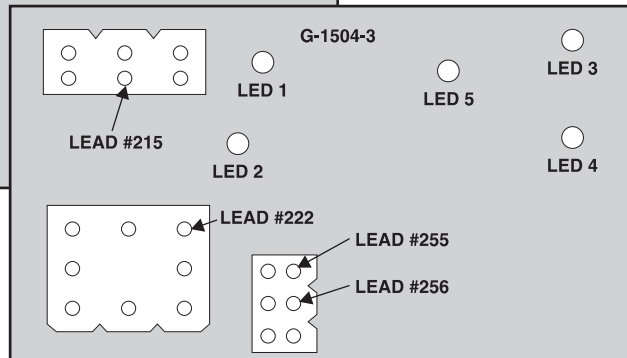

CONTROL BOARD FOR CODES BELOW 9700

Return to Section TOC

Return to Section TOC

Return to Section TOC

Return to Section TOC

Return to Master TOC

Return to Master TOC

Return to Master TOC

Return to Master TOC

**ACTIVE SCR TEST (continued)**

**FIGURE F.16 - Heat Sink Test Points.**

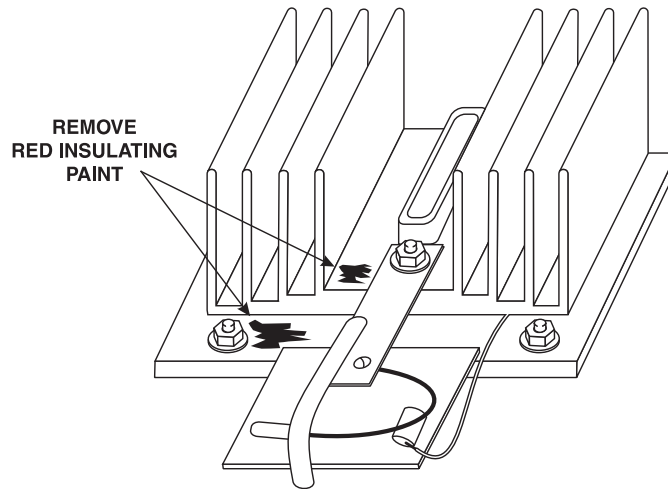

3. Remove the red insulating paint from the heat sink test points. See FIGURE F.16. **NOTE: DO NOT DISASSEMBLE THE HEAT SINKS.**

**FIGURE F.17 - SCR Tester Circuit and SCR connections.**

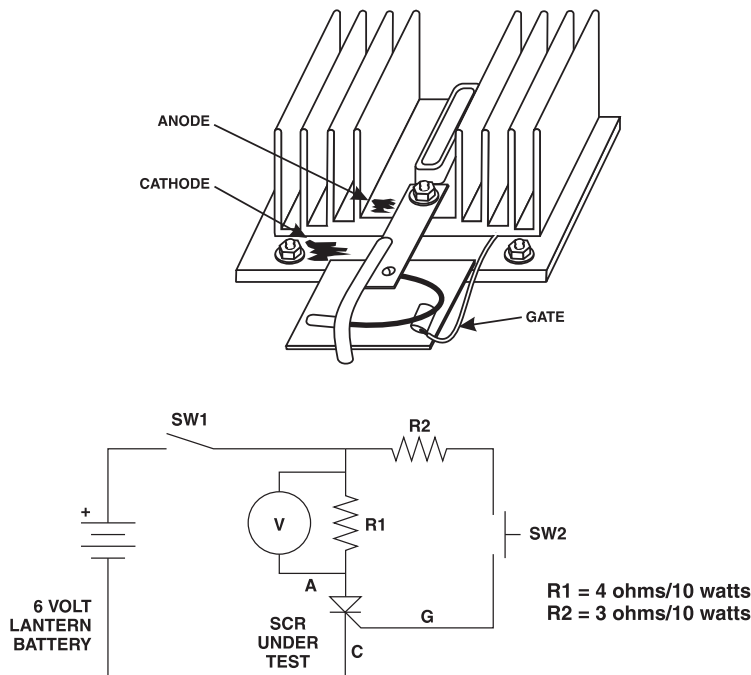

To test SCRs construct the circuit outlined above. Resistor values are plus or minus ten percent. The voltmeter scale should be low, approximately 0-5 or 0-10 volts DC.

4. Construct the circuit shown in Figure F.17. One 6-volt lantern battery can be used. Set voltmeter scale low, at approximately 0-5 volts or 0-10 volts.
- a. Test the voltage level of the battery. Short leads (A) and (C). Close switch SW-1. Battery voltage should be 4.5 volts or higher. If lower, replace the battery.

Return to Section TOC

Return to Master TOC

## ACTIVE SCR TEST (continued)

5. Connect the Tester to the SCR 1 as shown in Figure F.17.
  - a. Connect Tester lead (A) to the anode.
  - b. Connect Tester lead (C) to the cathode.
  - c. Connect Tester lead (G) to the gate.
6. Close switch SW-1.
 

NOTE: Switch SW-2 should be open.
7. Read meter for zero voltage.
  - a. If the voltage reading is higher than zero, the SCR is shorted.
8. Close or keep closed switch SW-1
9. Close switch SW-2 for 2 seconds and release and read meter.
  - a. If the voltage is 3 - 6 volts while the switch is closed and after the switch is open, the SCR is functioning.
  - b. If the voltages is 3-6 volts only when the switch is closed or there is no voltage when the switch is closed, the SCR is defective.
10. Open switch SW-1.
11. Reconnect the Tester leads. See **Figure F.17**.
  - a. Connect Tester lead (A) to the cathode.
  - b. Connect Tester lead (C) to the anode.
  - c. Disconnect Test lead (G) from the gate.
12. Close switch SW-1.
13. Read meter for zero voltage.
  - a. If the voltage is zero, the SCR is functioning.
  - b. If the voltage is higher than zero, the SCR is shorted.
14. Perform the Active Test Procedure outlined in Steps 5-13 for SCR's 2-6.
15. Replace all SCR assemblies that do not pass the above tests.
16. Replace all Molex Plugs onto the Firing Board and Control Board.

NOTE: Be sure battery is functioning properly. A low battery can affect the results of the test. Repeat Battery Test Procedure in Step 4 if needed.





**NORMAL OPEN CIRCUIT VOLTAGE WAVEFORM  
CONSTANT VOLTAGE INNERSHIELD  
MAXIMUM OUTPUT SETTING - NO LOAD**

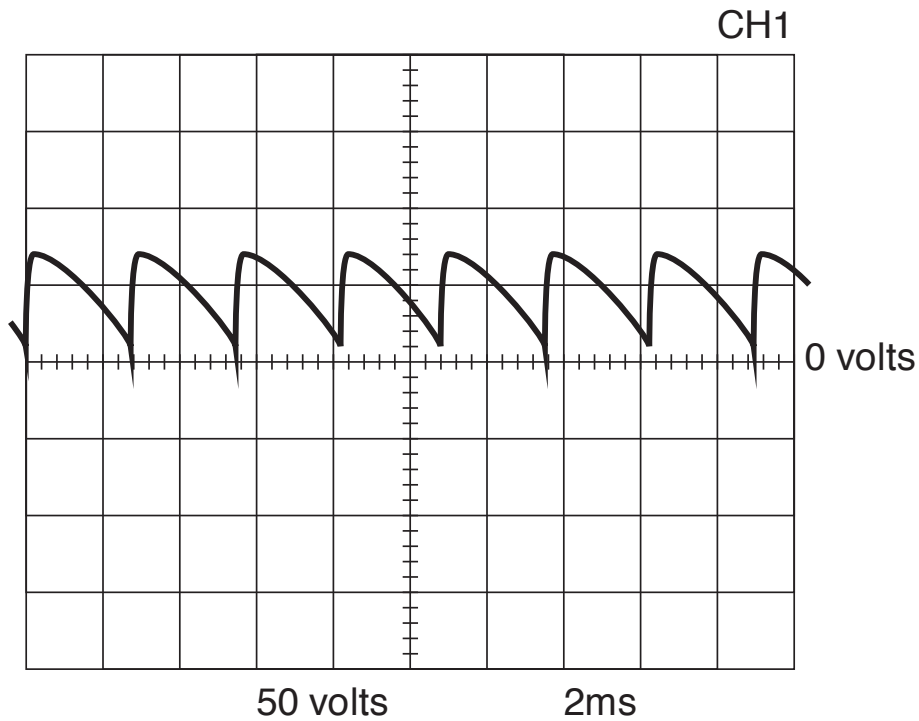

This is the typical DC open circuit voltage waveform generated from a properly operating machine. Note that each vertical division represents 50 volts and that each horizontal division represents 2 milliseconds in time.

Note: Scope probes connected at machine output terminals: (+) probe to positive terminal, (-) probe to negative terminal.

**SCOPE SETTINGS**

Volts/Div .....	50V/Div.
Horizontal Sweep .....	2 ms/Div.
Coupling .....	DC
Trigger .....	Internal

IDEALARC® DC-600



Return to Section TOC  
Return to Section TOC  
Return to Section TOC  
Return to Section TOC  
Return to Section TOC

Return to Master TOC  
Return to Master TOC  
Return to Master TOC  
Return to Master TOC  
Return to Master TOC



**TYPICAL OUTPUT VOLTAGE WAVEFORM - MACHINE LOADED  
CONSTANT VOLTAGE INNERSHIELD MODE**

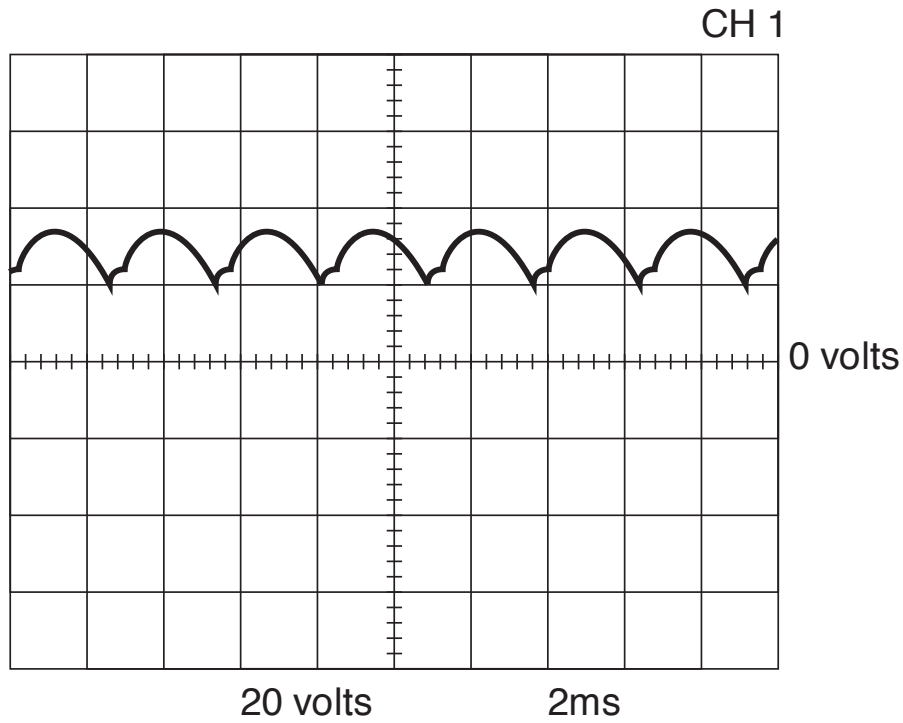

This is the typical DC open circuit voltage waveform generated from a properly operating machine. Note that each vertical division represents 20 volts and that each horizontal division represents 2 milliseconds in time. The machine was loaded with a resistance grid bank. The grid bank meters read 200 amps at 28VDC.

Note: Scope probes connected at machine output terminals: (+) probe to positive terminal, (-) probe to negative terminal.

**SCOPE SETTINGS**

Volts/Div .....	20V/Div.
Horizontal Sweep .....	2 ms/Div.
Coupling .....	DC
Trigger .....	Internal

**IDEALARC® DC-600**



Return to Section TOC

Return to Master TOC





**INPUT CONTACTOR (CR1) CLEANING/REPLACEMENT****⚠ WARNING**

Service and repair should be performed only by Lincoln Electric factory trained personnel. Unauthorized repairs performed on this equipment may result in danger to the technician or machine operator and will invalidate your factory warranty. For your safety and to avoid electrical shock, please observe all safety notes and precautions detailed throughout this manual.

If for any reason you do not understand the test procedures or are unable to perform the test/repairs safely, contact the Lincoln Electric Service Department for electrical troubleshooting assistance before you proceed. Call 1-888-935-3877.

**TEST DESCRIPTION**

This procedure will aid the technician in the cleaning or removal/replacement of the input contactor.

**MATERIALS NEEDED**

Phillips head screwdriver  
5/16" socket wrench  
Flat head screw driver  
Low pressure air source

## INPUT CONTACTOR (CR1) CLEANING/REPLACEMENT (continued)

### CLEANING PROCEDURE

1. Disconnect main AC input power supply to the machine.
2. Locate and get access to the Input Contactor (CR1) in the Input Box. See Figure F.18.
3. Remove the Input Contractor cover plate using a Phillips head screwdriver.



**DO NOT APPLY INPUT POWER TO THE MACHINE WITH THE INPUT CONTACTOR COVER PLATE REMOVED.**

4. Blow out any dirt or dust in or around the contacts with a low pressure air stream.
5. Inspect the contacts for signs of excessive wear, pitting, or contacts fused (stuck) to together.
  - a. If any of these conditions are present, replace the Input Contactor Assembly.
6. Replace the Input Contactor cover plate.

### CONTACTOR REPLACEMENT PROCEDURE

1. Disconnect main AC input power supply to the machine.
2. Locate and get access to the Input Contactor (CR1) in the Input Box. See Figure F.18.
3. Disconnect the main AC input power supply leads L1, L2, and L3 to the Input Contactor.
4. Disconnect the output leads T1, T2, and T3 from the Input Contactor.
5. Identify and label the leads connected to the Input Contactor coil and interlock. See wiring diagram.
6. Disconnect the leads from the Input Contactor coil (leads #271 & #272). See wiring diagram.
7. Disconnect the leads from the Input Contactor interlock (leads #211 & #212). See wiring diagram.
8. Remove the three self-tapping mounting screws using a 5/16" socket wrench. See Figure F.18.
9. Remove the Input Contactor.
10. Insert the replacement Input Contactor and install it following the procedures in reverse order.

NOTE: Be sure to reconnect all leads correctly.

**FIGURE F.18 - Input Contactor Cleaning and Removal**

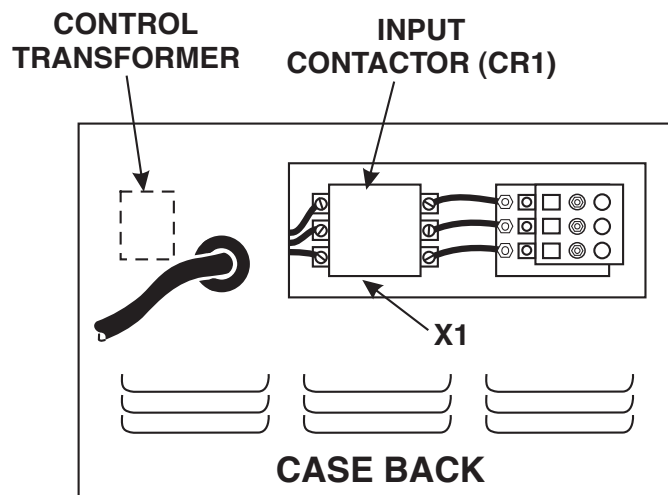



## SCR / SCR OUTPUT BRIDGE REMOVAL AND REPLACEMENT PROCEDURE

### WARNING

Service and repair should be performed only by Lincoln Electric factory trained personnel. Unauthorized repairs performed on this equipment may result in danger to the technician or machine operator and will invalidate your factory warranty. For your safety and to avoid electrical shock, please observe all safety notes and precautions detailed throughout this manual.

If for any reason you do not understand the test procedures or are unable to perform the test/repairs safely, contact the Lincoln Electric Service Department for electrical troubleshooting assistance before you proceed. Call 1-888-935-3877.

---

### TEST DESCRIPTION

This procedure will aid the technician in the removal and replacement of the SCR Output Bridge.

### MATERIALS NEEDED

- 9/16" socket wrench
- 1/2" socket wrench
- 1/2" open end wrench

## SCR / SCR OUTPUT BRIDGE REMOVAL AND REPLACEMENT PROCEDURE (continued)

FIGURE F.19 - Individual Heat Sink Removal

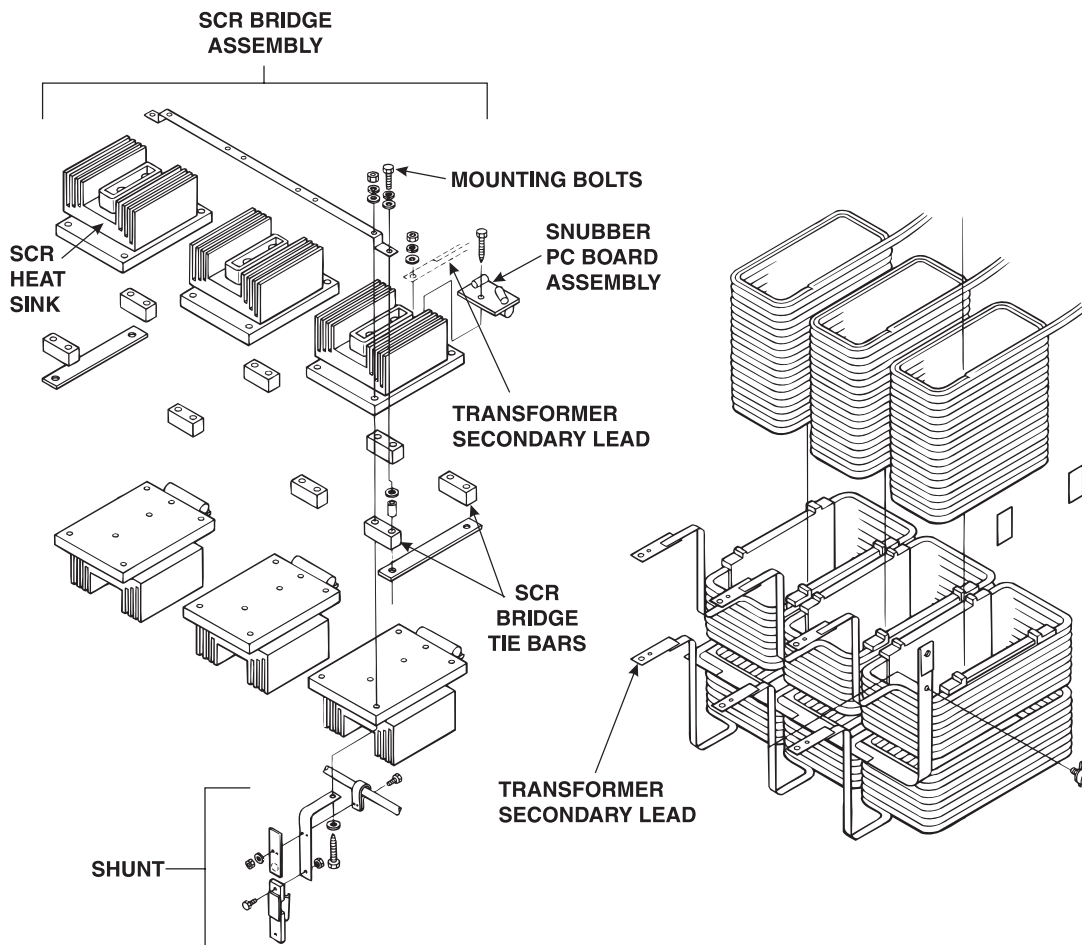

NOTE: If it is necessary to remove and replace only one or two individual SCRs and they are easy to work on, use these procedures.

1. Disconnect main AC input power supply to the machine.
2. Identify and label the following :
  - a. The transformer secondary lead (heavy aluminum conductor) connected to the anode of the SCR heat sink for each assembly to be removed. See Figure F.19.
  - b. The snubber leads for each SCR heat sink to be removed. See Figure F.19.
3. Disconnect the transformer secondary lead to the anode of the heat sink assembly using 1/2" socket wrench and 1/2" open end wrench.
4. Disconnect the gate lead to the SCR.
  - a. If the gate lead is cut, it will have to be re-soldered when the replacement SCR is installed.
  - b. If a new snubber board is used, install properly.

## SCR / SCR OUTPUT BRIDGE

### REMOVAL AND REPLACEMENT PROCEDURE (continued)

5. Remove the four thru bolts and associated nuts and washers holding the SCR heat sink to the bridge tie bars.
  - a. The main mounting bolts that mount the SCR bridge assembly to the frame rail may have to be loosened to slide the SCR Heat Sink out from under the buss jumper strap.
  - b. When all four thru-bolts are removed, the SCR Heat Sink directly above or below will be detached also. Support the SCR Heat Sink above or below. To hold the Heat Sink in place temporarily, insert one of the thru-bolts and replace the nut hand tight.
6. Install the replacement SCR Heat Sink in reverse order of removal.
  - a. Apply a thin layer of Lincoln E1868 (Dow Corning 340) heat sink compound to all bolted electrical connections on the aluminum heat sinks.

**NOTE:** If it is necessary to remove and replace the entire SCR Output Bridge Assembly, use these procedures.

**FIGURE F.20 - SCR Output Bridge Removal**

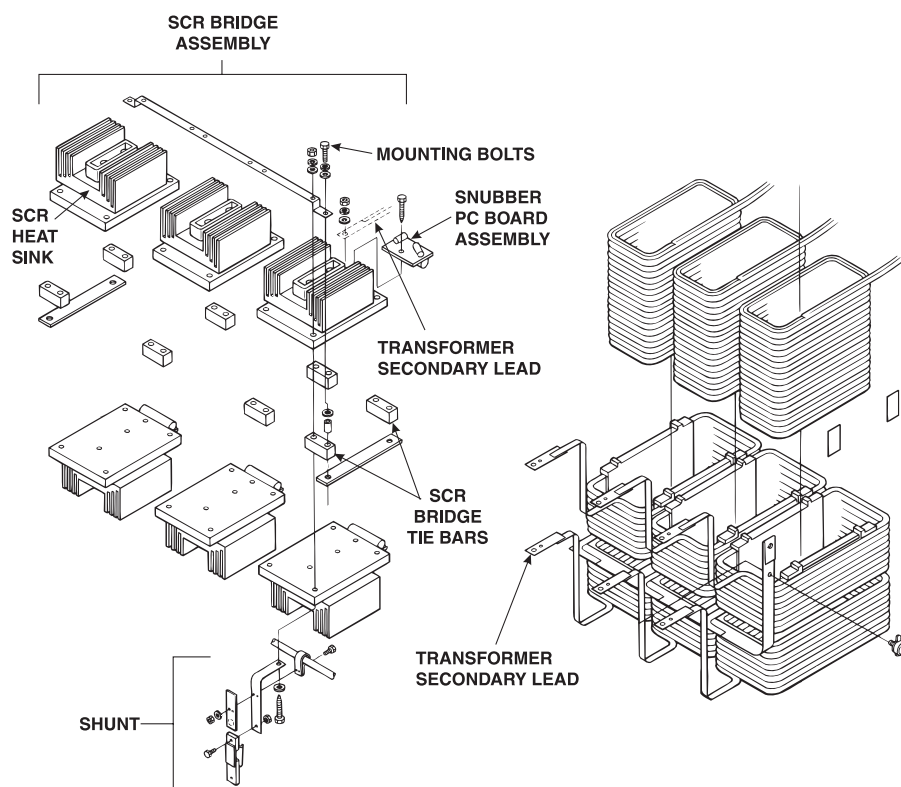

1. Disconnect the Gate Lead Molex Plug J4 from the Firing Board (later models).
  - a. If working on an earlier model and there is no Gate Lead Molex Board, identify and label the six Gate leads and cut or unsolder the leads from their respective snubber boards.
2. Remove the four self-tapping bolts that mount the SCR Bridge Assembly to the horizontal rails using a 9/16" socket wrench. See Figure F.20.
  - a. Note placement of insulating washers, tubes, and pads so they can be replaced correctly.
3. Identify and label the six transformer secondary (heavy aluminum) leads that connect to the anodes of the SCR Head Sink Assemblies. See Figure F.20.
4. Remove the transformer secondary leads using a 1/2" socket wrench.

## SCR / SCR OUTPUT BRIDGE REMOVAL AND REPLACEMENT PROCEDURE (continued)

5. Remove the bolt that connects the Shunt Assembly (heavy copper) lead to the SCR Bridge Assembly. The Shunt Assembly connects the positive Weld Output Terminal to the SCR Bridge Assembly.
6. Remove the small snubber lead from the left hand (facing the front of the machine) rear heat sink mounting bolt using a 1/2" socket wrench.
7. Clear all leads from any obstructions.
8. Lift the SCR Bridge Assembly straight up and out of the machine being sure that no leads become tangled or hooked on the other machine parts.
  - a. Be sure to locate the SCR Bridge Assembly on a stable work surface capable of holding the weight of the assembly.
9. Remove individual SCR Heat Sinks following the procedure described in A above.
10. Replace all insulating materials, including the insulators on the frame rail and all insulating tubes, when installing the SCR Output Bridge Assembly.
11. The Output Bridge assembly should be electrically isolated from ground. Check with an analog ohm meter. Minimum resistance is 500,000 ohms to ground.

## LIFT BAIL REMOVAL (INCLUDING MAIN TRANSFORMER, CHOKE AND OUTPUT BRIDGE ASSEMBLY)

### WARNING

Service and repair should be performed only by Lincoln Electric factory trained personnel. Unauthorized repairs performed on this equipment may result in danger to the technician or machine operator and will invalidate your factory warranty. For your safety and to avoid electrical shock, please observe all safety notes and precautions detailed throughout this manual.

If for any reason you do not understand the test procedures or are unable to perform the test/repairs safely, contact the Lincoln Electric Service Department for electrical troubleshooting assistance before you proceed. Call 1-888-935-3877.

---

### MATERIALS NEEDED

Miscellaneous Hand Tools

Return to Section TOC

Return to Section TOC

Return to Section TOC

Return to Section TOC

Return to Master TOC

Return to Master TOC

Return to Master TOC

Return to Master TOC

## LIFT BAIL REMOVAL (INCLUDING MAIN TRANSFORMER, CHOKE AND OUTPUT BRIDGE ASSEMBLY) (continued)

FIGURE F.21 - Lift Bail Removal

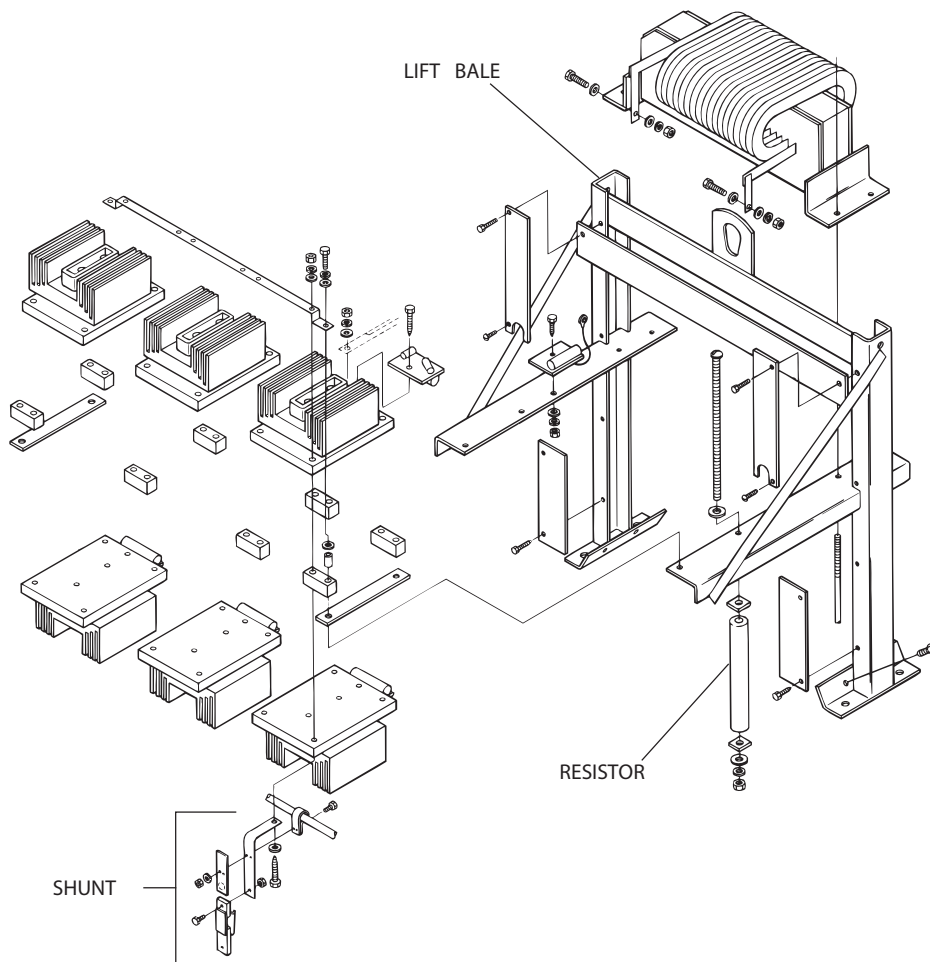

1. Disconnect gate leads.
  - a. On later models, remove gate lead Molex Plug J5 from the Firing Board.
  - b. On earlier models, identify and label the six gate leads and cut or unsolder the leads from their respective Snubber Board.
2. Disconnect the Shunt lead from the SCR Bridge Assembly. See Figure F.21.
3. Disconnect the leads from the secondary thermostat. See wiring diagram.
4. Disconnect auxiliary winding leads.
  - a. On later models, remove Molex Plug J5 from the Firing Board.
  - b. On earlier models, disconnect the following leads from the terminal strip in the Control Box: 31, 32A, 203, 204, 205, 206, 207, and 208.

## LIFT BAIL REMOVAL (INCLUDING MAIN TRANSFORMER, CHOKE AND OUTPUT BRIDGE ASSEMBLY) (continued)

5. Disconnect leads #215 and #216 from Relay CR4 and lead #231 from the splice connector.
6. Disconnect leads #211 and #212 from the ON/OFF PUSH BUTTON.
7. Disconnect lead #256 from the PILOT LIGHT.
8. Disconnect lead #271 from relay CR2 located in the Control Box.
9. Remove resistor R2 from the horizontal rail. See **Figure F.21**.
10. Cut and remove all cable ties and unbundle all wires.
11. Label and cut fan motor leads.
12. Separate leads #271, #211, and X2 from the harness.
13. Disconnect lead #272 from Input Contactor (CR1) coil.
14. Disconnect the heavy copper lead from the negative Weld Output Terminal.
15. Identify, label, and disconnect the Main Transformer leads from the Reconnect Panel and the three leads that go to the Input Contactor.
16. Remove the four mounting nuts that hold the Lift Bail Assembly to the Base.
17. Lift the Bail Assembly carefully straight up and out of the machine using a hoist. Be sure all leads are free to move with the assembly.

Return to Section TOC      Return to Section TOC      Return to Section TOC  
Return to Master TOC      Return to Master TOC      Return to Master TOC



**TRANSFORMER REMOVAL FROM LIFT BAIL ASSEMBLY PROCEDURE****⚠ WARNING**

Service and repair should be performed only by Lincoln Electric factory trained personnel. Unauthorized repairs performed on this equipment may result in danger to the technician or machine operator and will invalidate your factory warranty. For your safety and to avoid electrical shock, please observe all safety notes and precautions detailed throughout this manual.

If for any reason you do not understand the test procedures or are unable to perform the test/repairs safely, contact the Lincoln Electric Service Department for electrical troubleshooting assistance before you proceed. Call 1-888-935-3877.

---

**MATERIALS NEEDED**

9/16" socket wrench  
9/16" open end wrench  
1/2" socket wrench  
1/2" open end wrench  
3/8" socket wrench

## TRANSFORMER REMOVAL FROM LIFT BAIL ASSEMBLY PROCEDURE (continued)

FIGURE F.22 Transformer Bail Assembly Removal

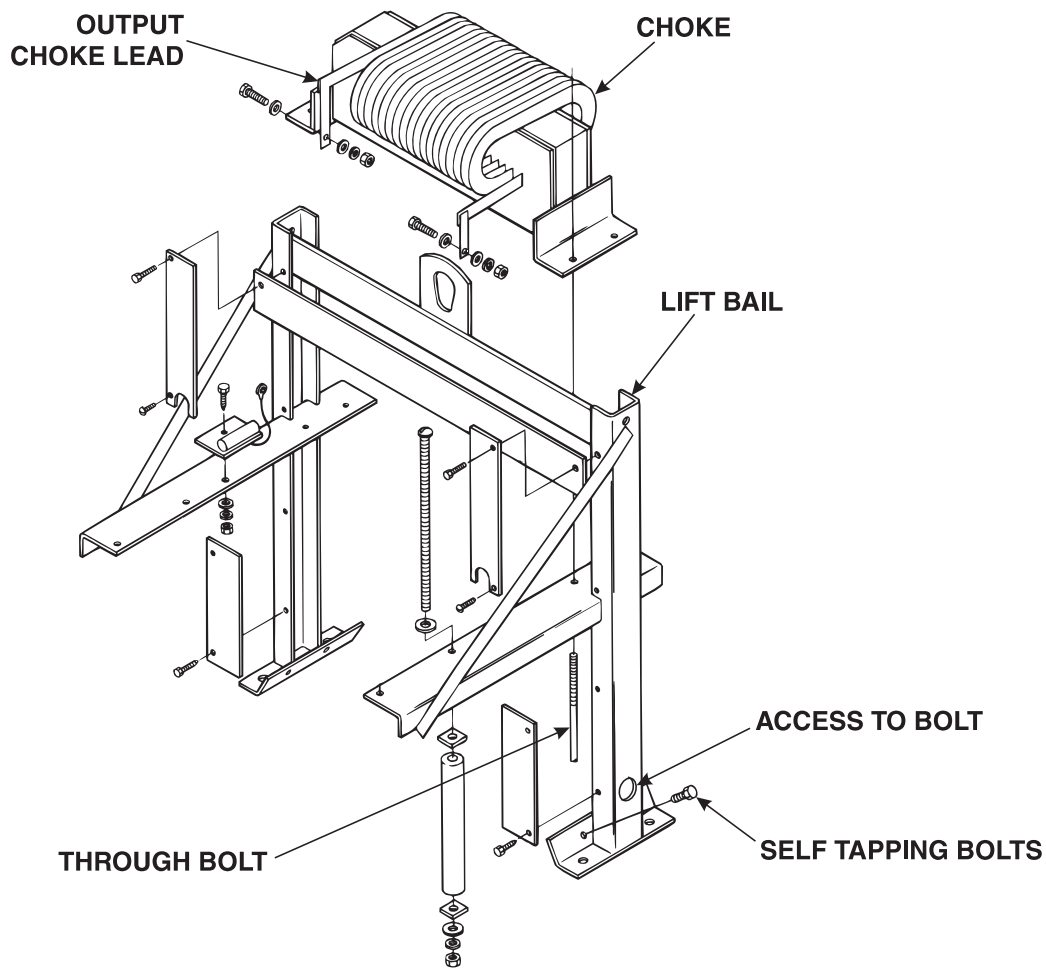

1. Remove the four screws that connect the top and side baffles around the Output Choke using a 3/8" socket wrench.
2. Remove the two bolts and nuts connecting the Output Choke leads to the copper strap and the main secondary common buss lead using a 9/16" socket wrench and a 9/16" open end wrench.
  - a. Identify and label the small snubber leads.
3. Remove the four nuts mounting the Output Choke to the transformer through bolts using a 9/16" socket wrench.
4. Lift the Output Choke straight up until the through bolts are cleared and then move it out toward the rear of the transformer.
5. Remove the six transformer secondary leads from the SCR Output Bridge Assembly using a 1/2" socket wrench and a 1/2" open end wrench.
  - a. Identify and label all leads, including the small snubber leads.
  - b. Clear the secondary leads so they are free to move when the transformer is removed.

## TRANSFORMER REMOVAL FROM LIFT BAIL ASSEMBLY PROCEDURE (continued)

6. Remove the four self-tapping bolts that hold the Lift Bail to the transformer base using a 9/16" socket wrench. **See Figure F.22.**

NOTE: There is one bolt on each side of the transformer that must be removed by inserting the wrench through the hole in Lift Bail.

7. Remove the Lift Bail and Output Bridge Assembly from the transformer by lifting the Lift Bail up slightly and sliding the Lift Bail towards the SCR Bridge.

## TRANSFORMER DISASSEMBLY

1. Identify and label all leads to the transformer.
2. Cut or unsolder all leads.
  - a. Cut the secondary leads. These must be re-TIG welded to the new transformer coils.
3. Remove the four nuts from the through bolts that hold the transformer together.
4. Attach a hoist to the top of the E Iron and lift from assembly.

Return to Section TOC

Return to Section TOC

Return to Section TOC

Return to Section TOC

Return to Master TOC

Return to Master TOC

Return to Master TOC

Return to Master TOC

## TRANSFORMER REMOVAL FROM LIFT BAIL ASSEMBLY PROCEDURE (continued)

Figure F.23 Transformer Coil Removal

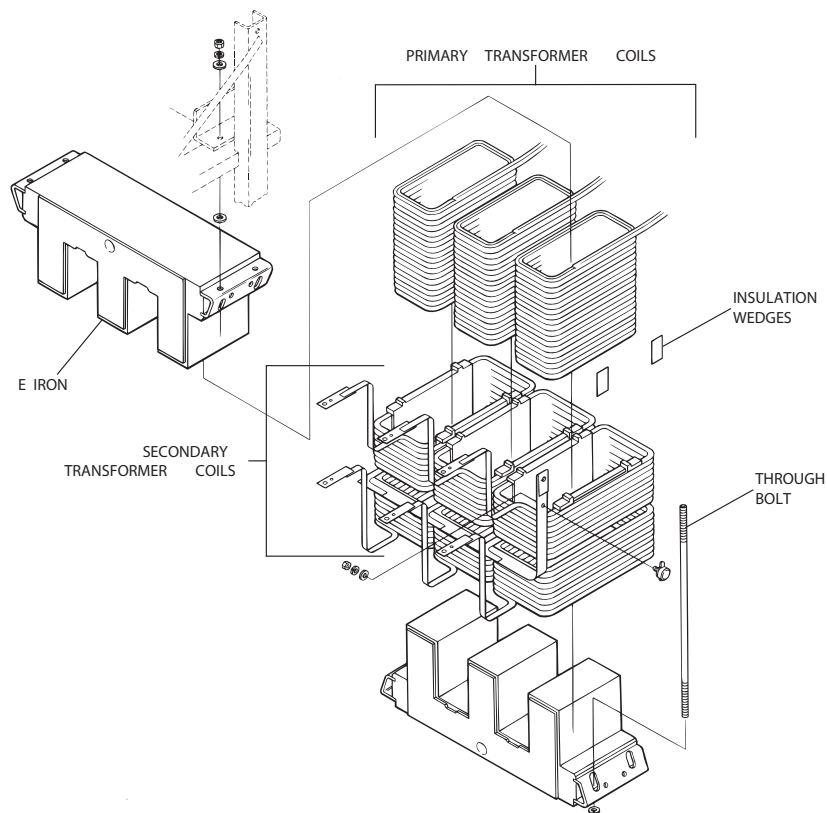

1. Label and cut leads to the coil(s) being removed. See Figure F.23.
- NOTE: To remove a main transformer coil, it is necessary to remove the secondary coil first.
2. Remove the secondary coil by breaking the seal caused by the epoxy paint and lifting the coil up away from the main transformer coil.
  - a. If the secondary coil is not being replaced, do not cut the lead to the secondary coil. With the lead attached, lift the coil off the main transformer coil and bend the coil and lead to the side.
3. Remove the main transformer coil.
  - a. Take out the insulated wedges that help keep the coil firmly seated on the iron E. If these do not dislodge easily, it will be necessary to force the coil off the iron E.
4. Replace the coil(s).
  - a. Be sure to replace all insulated wedges.
  - b. Using a high temperature industrial epoxy, such as Lincoln E-1603, "glue the primary coils in place" by applying the epoxy to the coil side and cell insulation opposite the wedges. Using a high temperature industrial epoxy, Such as Lincoln E-1603, "glue the secondary coils in place" from the iron to the coil sides.
5. Test for correct operation before replacing the transformer assembly back into the machine.
  - a. The primary coils should be ground tested at 2700VAC for 1 second. The secondary coils should be ground tested at 1500VAC for 1 second. The primary to secondary insulation should be tested at 2700VAC for 1 second.

## RETEST AFTER REPAIR

Should a machine under test be rejected for any reason requiring the removal of any mechanical part that could affect the machine's electrical characteristics, or if any electrical components are repaired or replaced, the machine must be retested.

### INPUT IDLE AMPS AND WATTS

Input volts/Phase/Hertz	Maximum Idle Amps	Input volts/Phase/Hertz
208/3/60	14.4	1.488
230/3/60	13.0	1.488
380/3/60	7.9	1.488
416/3/60	7.2	1.488
460/3/60	6.5	1.488
550/3/60	5.4	1.488
575/3/60	5.2	1.488
200/3/50	30.8	3.5
220/3/50	28.0	3.5
260/3/50	23.7	3.5
346/3/60	17.8	3.5
380/3/50	16.2	3.5
400/3/50	15.4	3.5
415/3/50	14.8	3.5
440/3/50	14.0	3.5
500/3/50	12.3	3.5
550/3/50	11.2	3.5

### OPEN CIRCUIT VOLTAGES

Mode	Input Hertz	Open Circuit Volts
Variable Voltage	60	74/70 DC
Variable Voltage	50	71/67 DC
Auxiliary Output (#31-#32)	60	123/117 AC
Auxiliary Output (#31-#32)	50	118/112 AC

## RETEST AFTER REPAIR (Continued)

Should a machine under test be rejected for any reason requiring the removal of any mechanical part that could affect the machine's electrical characteristics, or if any electrical components are repaired or replaced, the machine must be retested.

### MAXIMUM ACCEPTABLE OUTPUT VOLTAGE – AT MINIMUM OUTPUT SETTINGS

Mode	Input Hertz	Load
Variable Voltage	60	75 Amps@24/26VDC
Variable Voltage	50	75 Amps@24/26VDC
Constant Voltage Innershield	60	100 Amps@11.5/12.5VDC
Constant Voltage Innershield	50	100 Amps@11.5/14.5VDC

### MINIMUM ACCEPTABLE OUTPUT VOLTAGE – AT MAXIMUM OUTPUT SETTINGS

Mode	Input Hertz	Load
Variable Voltage	60/50	750 Amps@44/50VDC
Constant Voltage Innershield	60/50	750 Amps@44/50VDC

Return to Master TOC

Return to Master TOC

Return to Master TOC

Return to Master TOC

Electrical Diagrams .....G-1

Wiring Diagram (Codes 9773, 9775, 9776, 9778, 9779, 9780, 9781, 9782, 9910, 10282, 10283, 10410, 10411, 10412, 10413, 10414, 10416, 10417) (L8750) .....G-2

Wiring Diagram (Codes 9774, 9777, 10419) (L8751) .....G-3

Wiring Diagram (Code 9793) (L8752) .....G-4

Wiring Diagram (Code 9832) (L7779) .....G-5

Wiring Diagram (Codes 10407, 10408, 10409, 10415) (L10575) .....G-6

Wiring Diagram (Code 10418) (L10576) .....G-7

Operating Schematic (Codes 9773, 9775, 9776, 9778, 9779, 9780, 9781, 9782, 9910, 10282, 10283, 10410, 10411, 10412, 10413, 10414, 10416, 10417) (G2259) .....G-8

Operating Schematic (Codes 10407, 10408, 10409, 10415, 10418) (G3150) .....G-9

Control Board Schematic (G2312) .....G-10

Firing Board Schematic (L8337) .....G-11

\* **NOTE:** Many PC Board Assemblies are now totally encapsulated, surface mounted and or multi-layered and are therefore considered to be unserviceable. Assembly drawings of these boards are no longer provided.

WIRING DIAGRAM - (CODES 9773, 9775, 9776, 9778, 9779, 9780, 9781, 9782, 9910, 10282, 10283, 10410, 10411, 10412, 10413, 10414, 10416, 10417) (L8750)

Return to Section TOC

Return to Section TOC

Return to Section TOC

Return to Section TOC

Return to Master TOC

Return to Master TOC

Return to Master TOC

Return to Master TOC

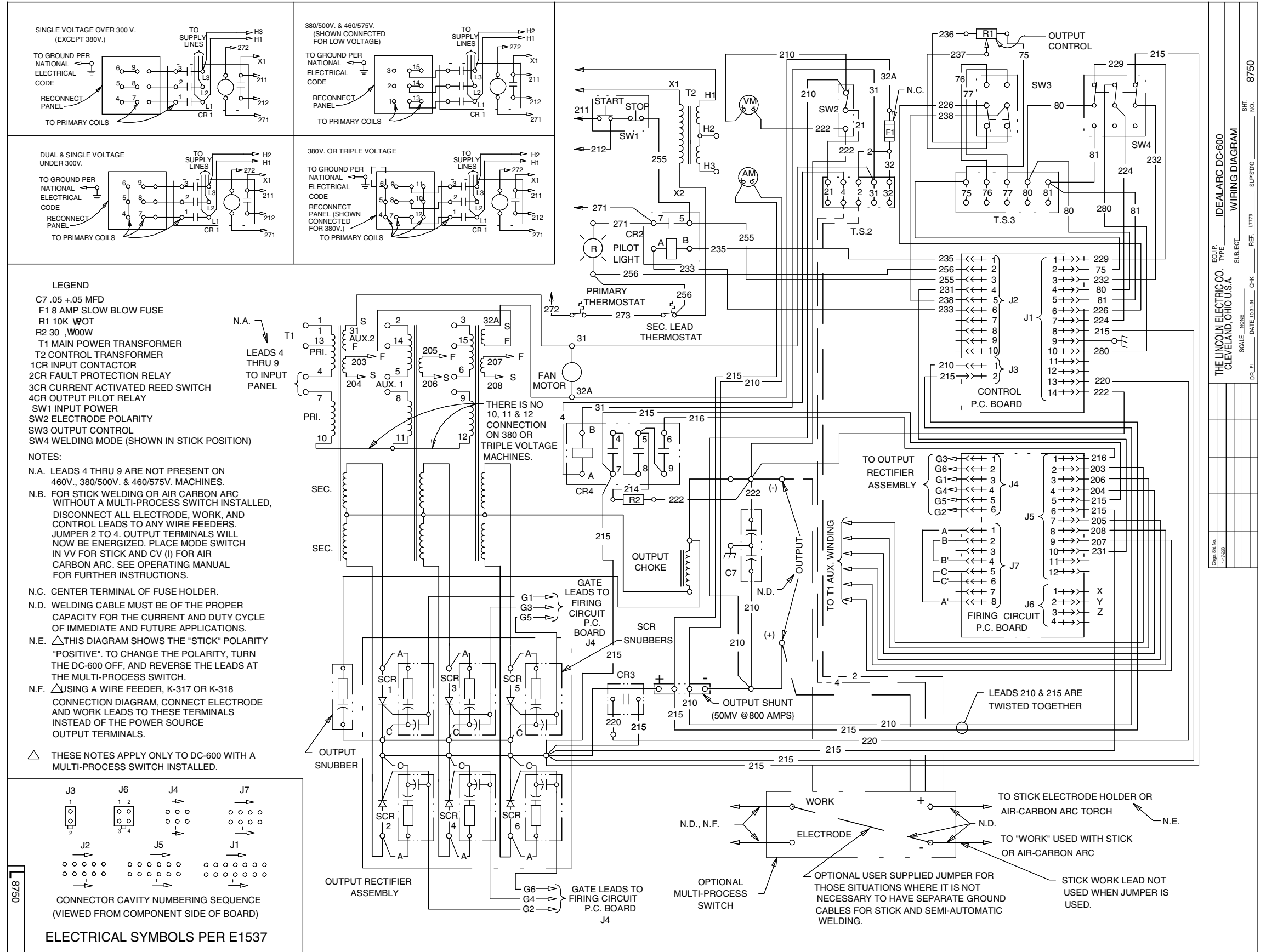

- LEGEND**
- C7 .05 +.05 MFD
  - F1 8 AMP SLOW BLOW FUSE
  - R1 10K  $\frac{W}{OT}$
  - R2 30  $\frac{W}{OOW}$
  - T1 MAIN POWER TRANSFORMER
  - T2 CONTROL TRANSFORMER
  - 1CR INPUT CONTACTOR
  - 2CR FAULT PROTECTION RELAY
  - 3CR CURRENT ACTIVATED REED SWITCH
  - 4CR OUTPUT PILOT RELAY
  - SW1 INPUT POWER
  - SW2 ELECTRODE POLARITY
  - SW3 OUTPUT CONTROL
  - SW4 WELDING MODE (SHOWN IN STICK POSITION)
- NOTES:**
- N.A. LEADS 4 THRU 9 ARE NOT PRESENT ON 460V., 380/500V. & 460/575V. MACHINES.
  - N.B. FOR STICK WELDING OR AIR CARBON ARC WITHOUT A MULTI-PROCESS SWITCH INSTALLED, DISCONNECT ALL ELECTRODE, WORK, AND CONTROL LEADS TO ANY WIRE FEEDERS. JUMPER 2 TO 4. OUTPUT TERMINALS WILL NOW BE ENERGIZED. PLACE MODE SWITCH IN VV FOR STICK AND CV (I) FOR AIR CARBON ARC. SEE OPERATING MANUAL FOR FURTHER INSTRUCTIONS.
  - N.C. CENTER TERMINAL OF FUSE HOLDER.
  - N.D. WELDING CABLE MUST BE OF THE PROPER CAPACITY FOR THE CURRENT AND DUTY CYCLE OF IMMEDIATE AND FUTURE APPLICATIONS.
  - N.E.  $\Delta$  THIS DIAGRAM SHOWS THE "STICK" POLARITY "POSITIVE". TO CHANGE THE POLARITY, TURN THE DC-600 OFF, AND REVERSE THE LEADS AT THE MULTI-PROCESS SWITCH.
  - N.F.  $\Delta$  USING A WIRE FEEDER, K-317 OR K-318 CONNECTION DIAGRAM, CONNECT ELECTRODE AND WORK LEADS TO THESE TERMINALS INSTEAD OF THE POWER SOURCE OUTPUT TERMINALS.
  - $\Delta$  THESE NOTES APPLY ONLY TO DC-600 WITH A MULTI-PROCESS SWITCH INSTALLED.

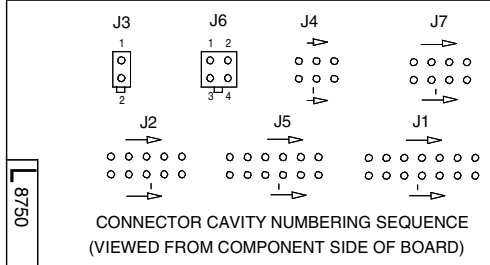

ELECTRICAL SYMBOLS PER E1537

DRG. SH. NO.	11/7/82
EQUIP. TYPE	IDEALARC DC-600
SUBJECT	WIRING DIAGRAM
SCALE	1:1
DATE	03/31/82
CHK.	
REF.	L1779
SUP. NO.	
SH. NO.	8750

NOTE: This diagram is for reference only. It may not be accurate for all machines covered by this manual. The wiring diagram specific to your code is pasted inside one of the enclosure panels of your machine.



WIRING DIAGRAM - (CODES 9774, 9777, 10419) (L8751)

Return to Section TOC

Return to Section TOC

Return to Section TOC

Return to Section TOC

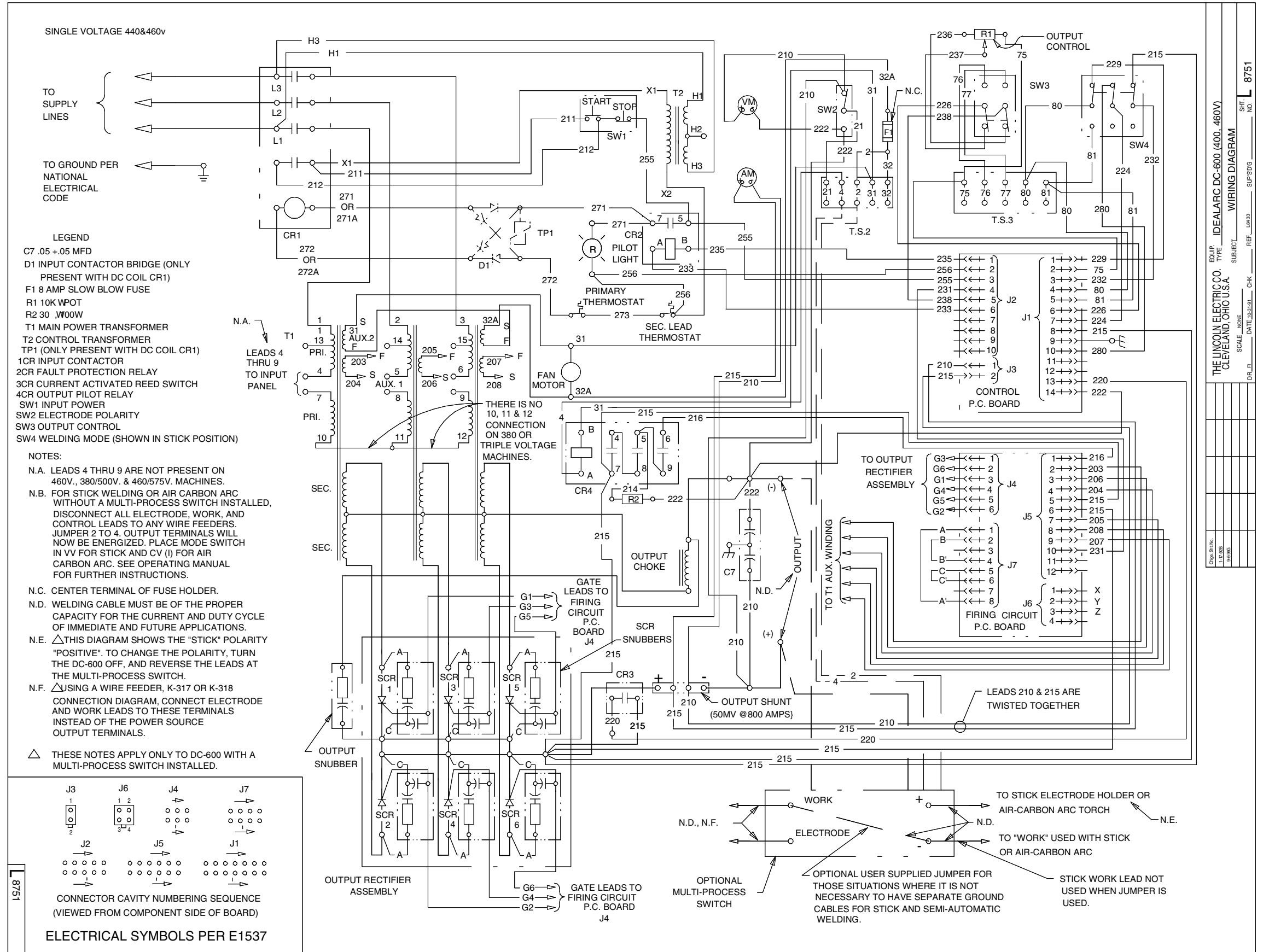

DR. FR. DATE: 10/13/91. CHK. REF. L8751. SUP/SDG. NO. 8751

EQUIP. TYPE: IDEALARC DC-600 (400, 460V)

SUBJECT: WIRING DIAGRAM

SCALE: NONE

THE LINCOLN ELECTRIC CO. CLEVELAND, OHIO U.S.A.

NOTE: This diagram is for reference only. It may not be accurate for all machines covered by this manual. The wiring diagram specific to your code is pasted inside one of the enclosure panels of your machine.



WIRING DIAGRAM - (CODE 9832) (L7779)

Return to Section TOC  
Return to Master TOC

Return to Section TOC  
Return to Master TOC

Return to Section TOC  
Return to Master TOC

Return to Section TOC  
Return to Master TOC

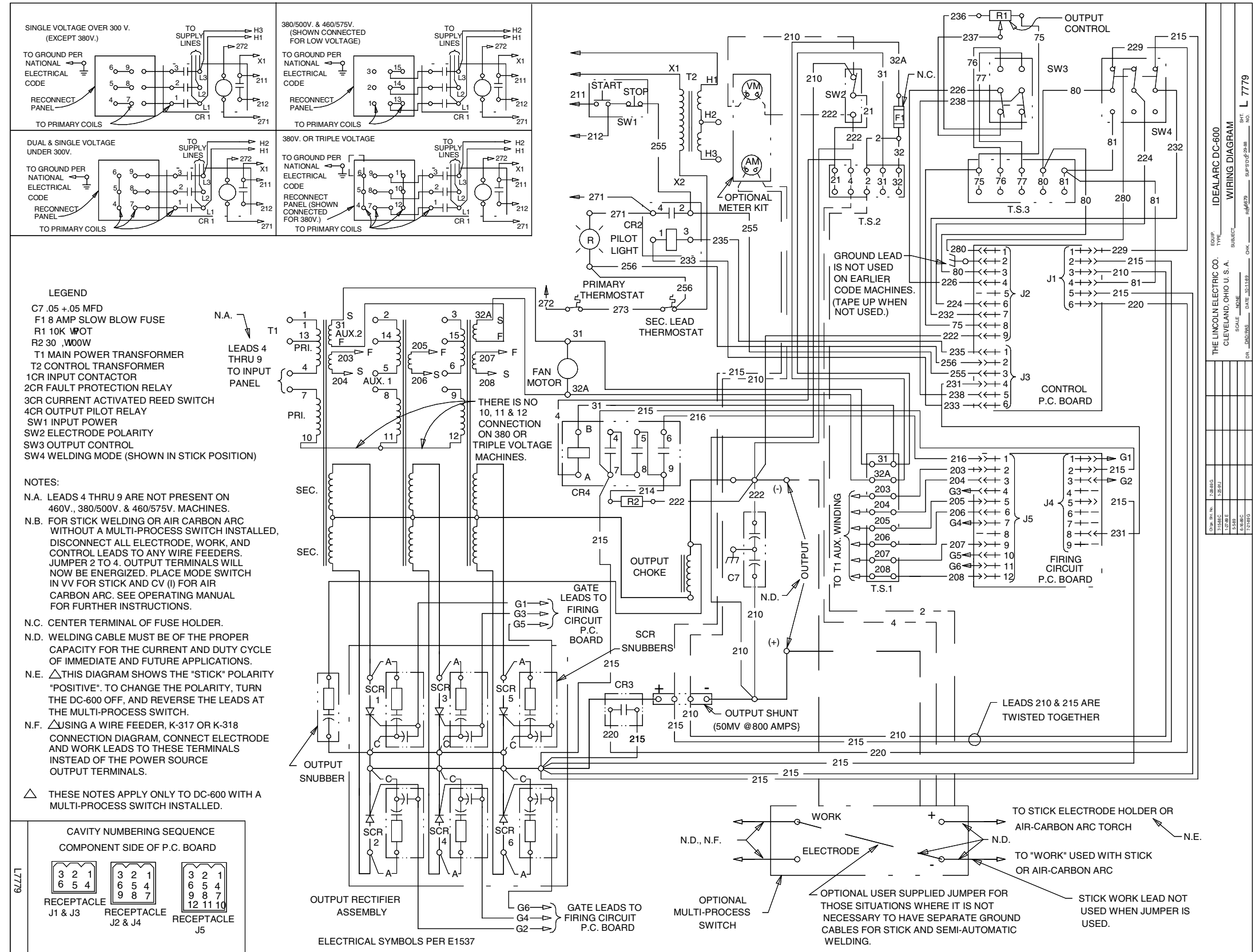

DATE	2-8-85	BY	WJ
REV.	1-2-87	BY	WJ
REV.	1-2-88	BY	WJ
REV.	8-5-88	BY	WJ
REV.	1-2-88	BY	WJ

THE LINCOLN ELECTRIC CO.  
 CLEVELAND, OHIO U.S.A.  
 SCALE: 1/8" = 1"

EQUIP. TYPE: IDEALARC DC-600  
 SUBJECT: WIRING DIAGRAM  
 PART NO.: L 7779  
 OR. DRAWING: DC-600-32-38

NOTE: This diagram is for reference only. It may not be accurate for all machines covered by this manual. The wiring diagram specific to your code is pasted inside one of the enclosure panels of your machine.

WIRING DIAGRAM - (CODES 10407, 10408, 10409, 10415) (L10575)

Return to Section TOC

Return to Section TOC

Return to Section TOC

Return to Section TOC

Return to Master TOC

Return to Master TOC

Return to Master TOC

Return to Master TOC

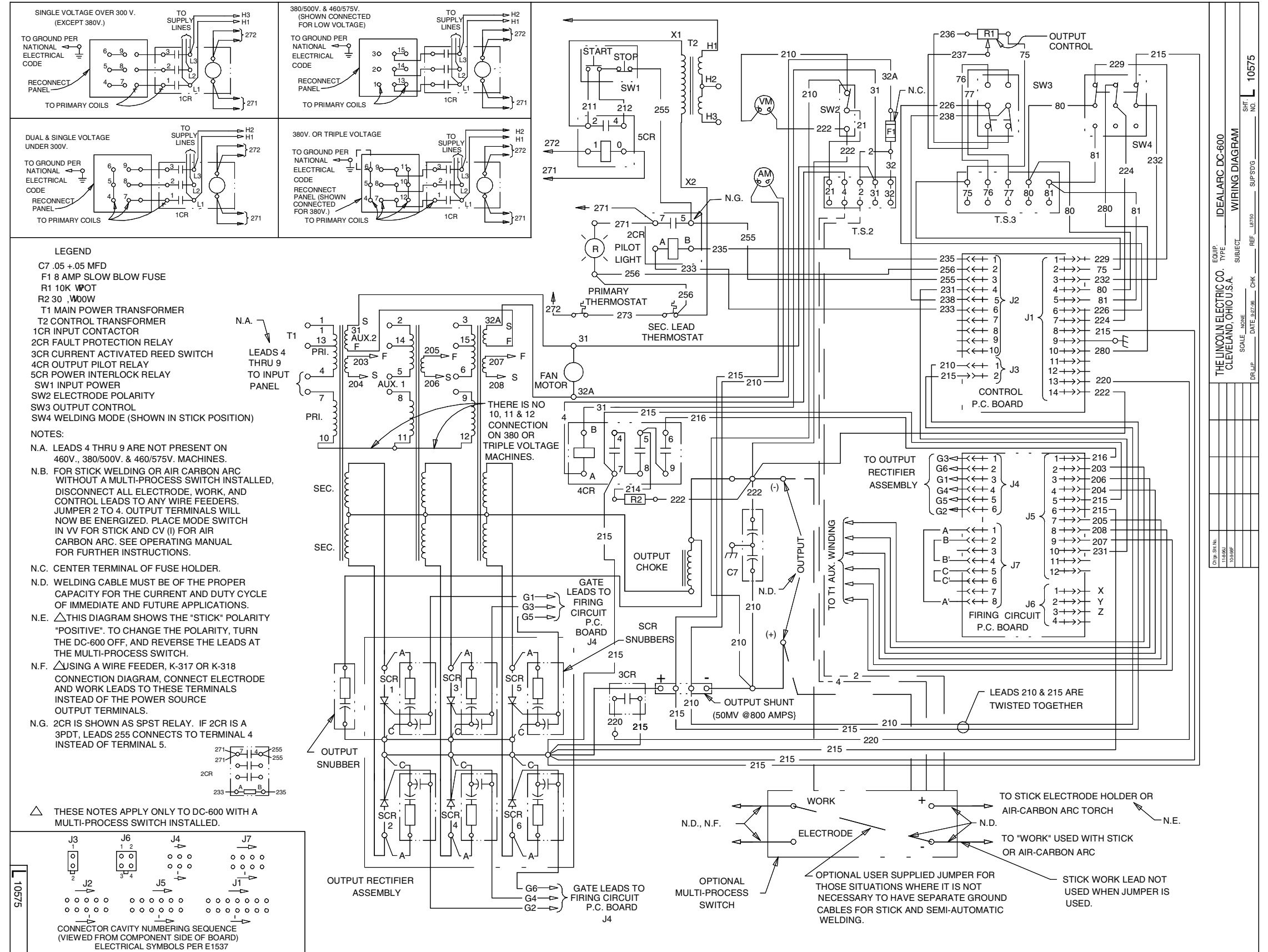

10575

THE LINCOLN ELECTRIC CO. CLEVELAND, OHIO U.S.A.

EQUIP. TYPE IDEALARC DC-600

SUBJECT WIRING DIAGRAM

SCALE INCHES

DATE 9-22-86

CHK

REF E1537

SUP'D'G

SHT. NO. 10575

NOTE: This diagram is for reference only. It may not be accurate for all machines covered by this manual. The wiring diagram specific to your code is pasted inside one of the enclosure panels of your machine.



WIRING DIAGRAM - CODE 10418) (L10576)

Return to Section TOC

Return to Section TOC

Return to Section TOC

Return to Section TOC

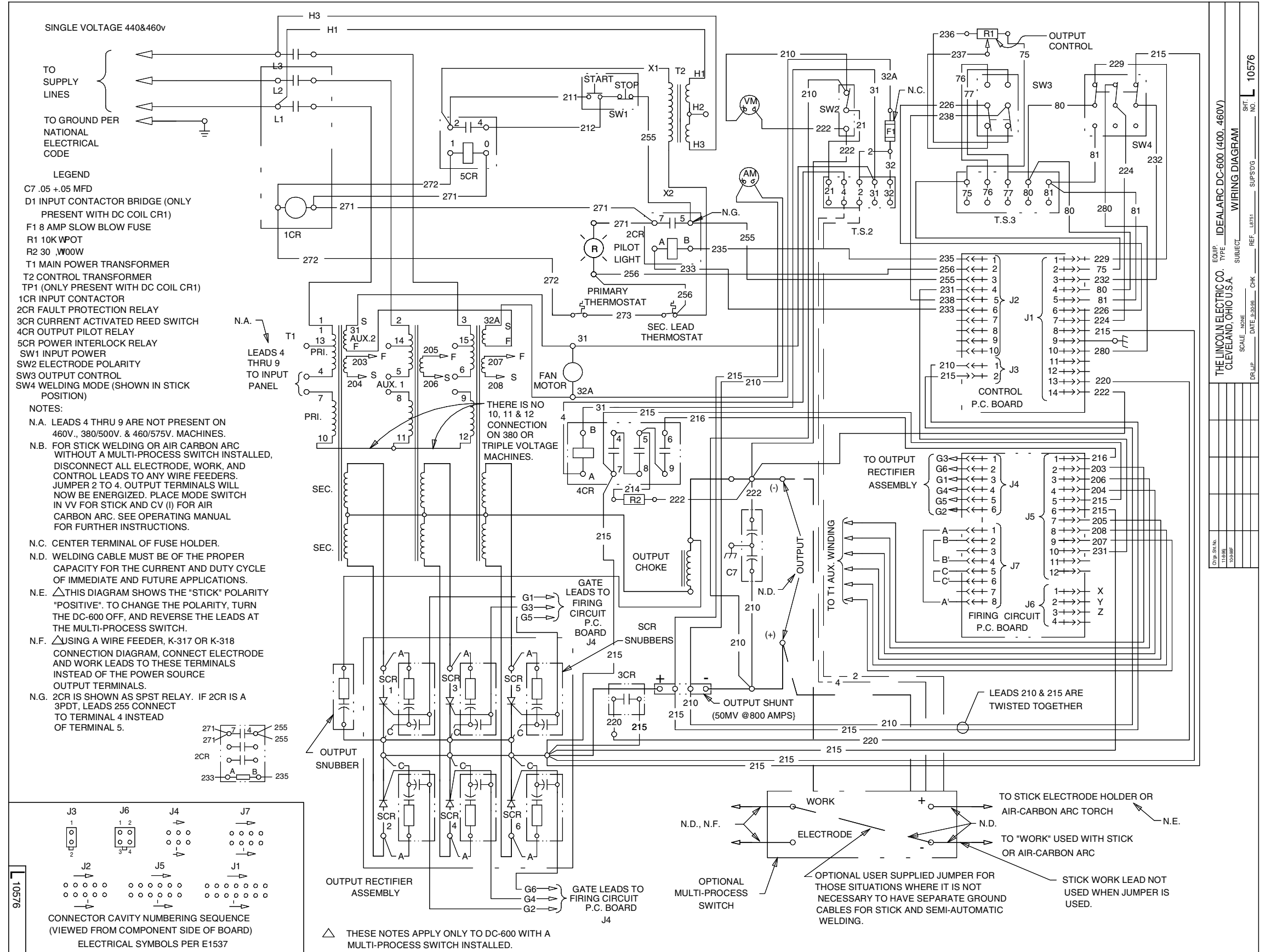

EQUIP. TYPE IDEALARC DC-600 (400, 460V)  
 SUBJECT WIRING DIAGRAM  
 REF. L10576  
 SCALE NONE  
 DATE 2-23-95  
 DR/LJP  
 SUP/STG  
 10576

**NOTE:** This diagram is for reference only. It may not be accurate for all machines covered by this manual. The wiring diagram specific to your code is pasted inside one of the enclosure panels of your machine.





SCHEMATIC - CONTROL BOARD (G2312)

Return to Section TOC  
Return to Master TOC

Return to Section TOC  
Return to Master TOC

Return to Section TOC  
Return to Master TOC

Return to Section TOC  
Return to Master TOC

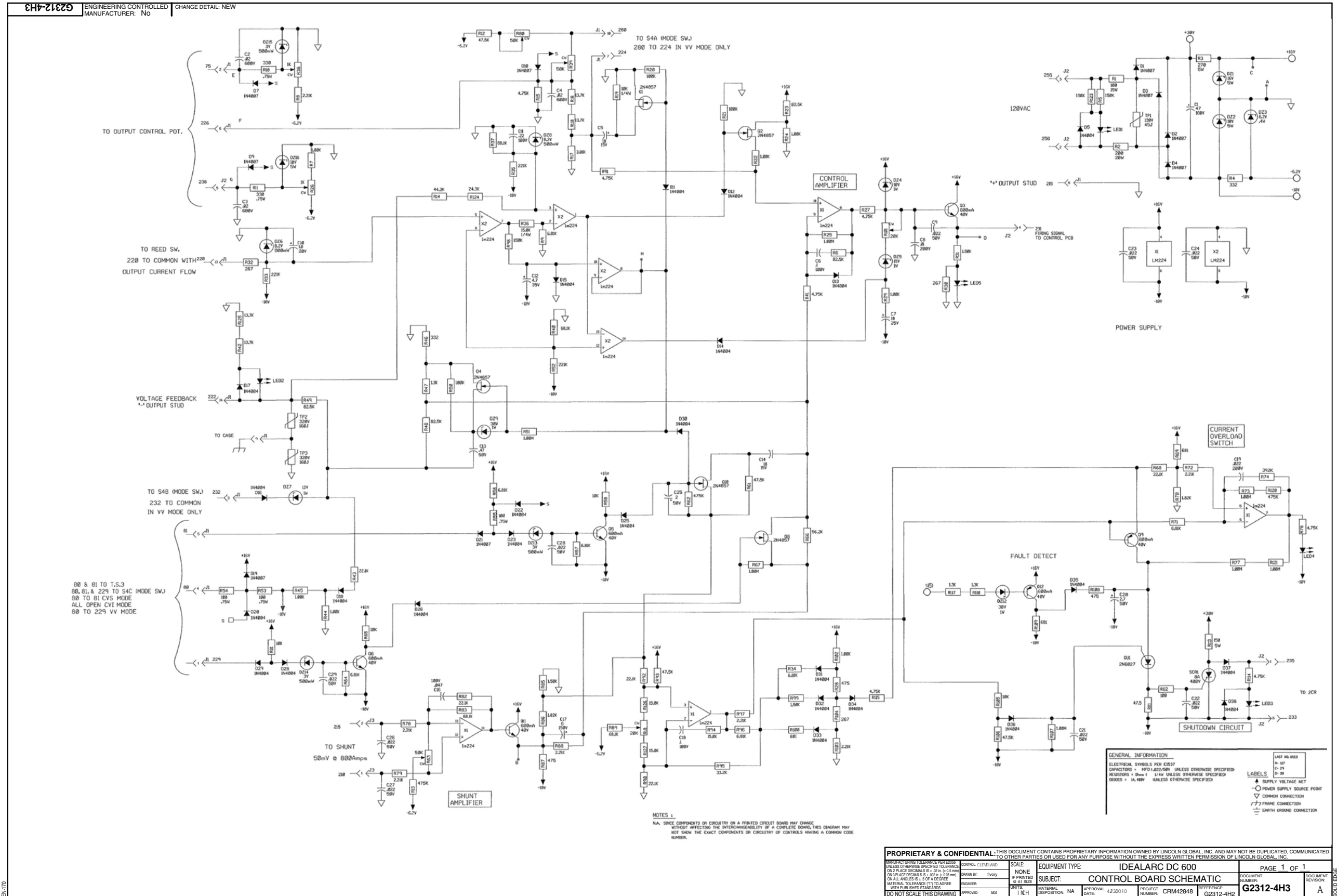

NOTE: This diagram is for reference only. It may not be accurate for all machines covered by this manual.



SCHEMATIC - FIRING BOARD (L8337)

Return to Section TOC

Return to Section TOC

Return to Section TOC

Return to Section TOC

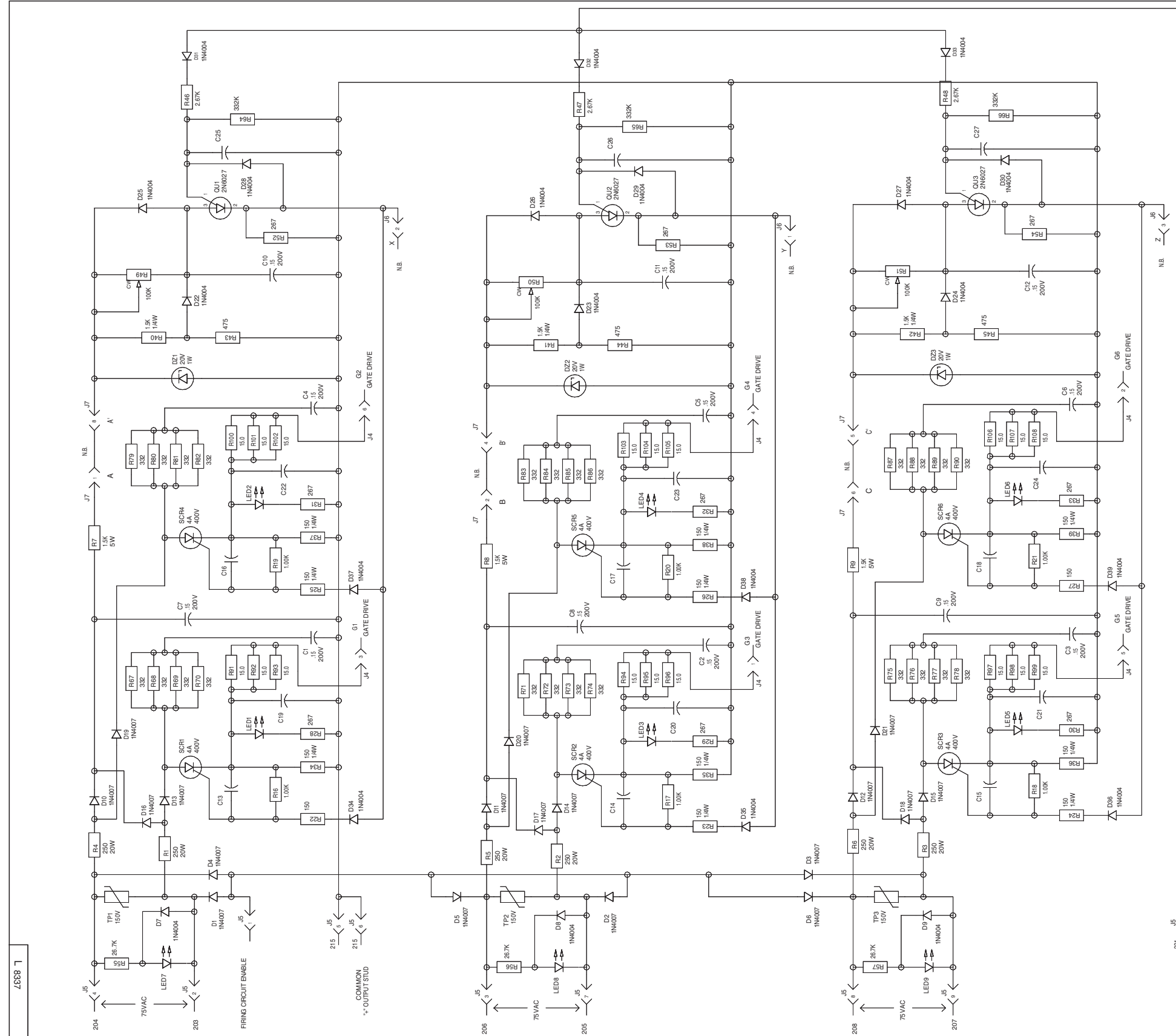

**NOTES:**

- N.A. SINCE COMPONENTS OR CIRCUITRY ON A PRINTED CIRCUIT BOARD MAY CHANGE WITHOUT AFFECTING THE INTERCHANGIBILITY OF A COMPLETE BOARD, THIS DRAWING MAY NOT SHOW THE EXACT COMPONENTS OR CIRCUITRY OF CONTROL FIRING A COMMON CODE NUMBER.
- N.B. J6 IS USED TO CONNECT THE FIRING PCBs IN TWO LIKE MACHINES TO PARALLEL THE OUTPUTS. J7 REMAINS IN THE MASTER FIRING PCB WHILE J7 IS REMOVED FROM THE SLAVE FIRING PCB.

**GENERAL INFORMATION**

ELECTRICAL SYMBOLS PER E1537  
 CAPACITORS = MFD (UNLESS OTHERWISE SPECIFIED)  
 RESISTORS = Ohms (UNLESS OTHERWISE SPECIFIED)  
 DIODES = 1A 400V (UNLESS OTHERWISE SPECIFIED)

**LABELS**

- A SUPPLY VOLTAGE NET
- POWER SUPPLY SOURCE POINT
- △ COMMON CONNECTION
- ⚡ FRAME CONNECTION
- ⊥ EARTH GROUND CONNECTION

FILE: L8337\_5HA

1/10/82 RD  
 1/28/1 MDW

DR. J.A.S. DATE 3-22-80 DA. CHK. SJP/S.D.G. NO. L 8337

THE LINCOLN ELECTRIC CO.  
 CLEVELAND, OHIO U.S.A.  
 SCALE NONE

EQUIP. TYPE \_\_\_\_\_  
 SUBJECT \_\_\_\_\_  
 SHT. NO. \_\_\_\_\_

NOTE: This diagram is for reference only. It may not be accurate for all machines covered by this manual.

