

QUICKMIG 250 & 300

For use with machines having code numbers: 50605 - 50606



SERVICE MANUAL



INDEX OF CONTENTS

TECHNICAL SPECIFICATIONS.....	3
MAJOR COMPONENTS LOCATION	18
TROUBLESHOOTING AND REPAIR SECTION.....	20
SIDE PANELS REMOVAL AND DC BUS CAPACITORS DISCHARGE PROCEDURE	24
INVERTER BOARD RESISTANCE TEST	27
RECTIFICATION BOARD RESISTANCE TEST	29
INVERTER BOARD VOLTAGE TEST	31
AUXILIARY POWER BOARD TEST	33
CONTROL BOARD TEST	35
DISASSEMBLY OPERATIONS.....	37
RETEST AFTER REPAIR.....	43
CALIBRATION PROCEDURE.....	44
ELECTRICAL SCHEMATICS	45
NOTE	46

TECHNICAL SPECIFICATIONS

NAME		INDEX			
QUICKMIG® 250		K14379-1			
QUICKMIG® 300		K14380-1			
INPUT					
	Input Voltage U ₁	EMC Class		Frequency	
QUICKMIG® 250	400V ± 10%, 3-phase	A		50/60Hz	
QUICKMIG® 300					
	Process	Input Power at Rated Cycle (40°C)	Input Amperes I _{1max}	PF	
QUICKMIG® 250	GMAW/FCAW	13,5 kVA @ 35% Duty Cycle	19,2 A	0,58	
	SMAW	15,5 kVA @ 25% Duty Cycle	21,9 A	0,56	
QUICKMIG® 300	GMAW/FCAW	15 kVA @ 35% Duty Cycle	22,0 A	0,65	
	SMAW	14 kVA @ 35% Duty Cycle	19,8 A	0,62	
RATED OUTPUT					
	Process	Open Circuit Voltage	Duty Cycle 40°C (based on a 10 min. period)	Output Current	Output Voltage
QUICKMIG® 250	GMAW	72Vdc	35%	250A	26,5Vdc
			60%	230A	25,5Vdc
			100%	175A	22,8Vdc
	FCAW		35%	250A	26,5Vdc
			60%	230A	25,5Vdc
			100%	175A	22,8Vdc
	SMAW		35%	250A	30Vdc
			60%	190A	27,6Vdc
			100%	150A	26Vdc
QUICKMIG® 300	GMAW	72Vdc	35%	300A	29Vdc
			60%	230A	25,5Vdc
			100%	175A	22,8Vdc
	FCAW		35%	300A	29Vdc
			60%	230A	25,5Vdc
			100%	175A	22,8Vdc
	SMAW		35%	250A	30Vdc
			60%	190A	27,6Vdc
			100%	150A	26Vdc
WELDING CURRENT RANGE					
	GMAW	FCAW	SMAW		
QUICKMIG® 250	50A÷250A	50A÷250A	10A÷250A		
QUICKMIG® 300	50A÷300A	50A÷300A	10A÷250A		
RECOMMENDED INPUT CABLE AND FUSE SIZES					
	Fuse Type gR or Circuit Breaker Type D		Power Lead		
QUICKMIG® 250	16A, 400V AC		4 Conductor, 2,5mm ²		
QUICKMIG® 300	16A, 400V AC		4 Conductor, 2,5mm ²		

WELDING VOLTAGE REGULATION RANGE				
	GMAW		FCAW	
QUICKMIG® 250	16,5 V ÷ 26,5 V		16,5 V ÷ 26,5 V	
QUICKMIG® 300	16,5 V ÷ 29 V		16,5 V ÷ 29 V	
WIRE FEED SPEED RANGE / WIRE DIAMETER				
	WFS Range	Drive Rolls	Drive roll diameter	
QUICKMIG® 250	1.5 ÷ 18m/min	4	Ø30	
QUICKMIG® 300				
	Solid Wires	Aluminum Wires	Cored Wires	
QUICKMIG® 250	0.6 ÷ 1.2 mm	1.0 ÷ 1.2 mm	0.8 ÷ 1.0 mm	
QUICKMIG® 300				
DIMENSION				
	Weight	Height	Width	Length
QUICKMIG® 250	49 kg	760 mm	395 mm	830 mm
QUICKMIG® 300	50 kg			
OTHERS				
	Protection Rating	Maximum Gas Pressure	Operating Humidity (t=20°C)	
QUICKMIG® 250	IP23	0,5MPa (5 bar)	≤ 90 %	
QUICKMIG® 300				
	Operating Temperature	Storage Temperature		
QUICKMIG® 250	from -10°C to +40°C	from -25°C to 55°C		
QUICKMIG® 300				

Electromagnetic Compatibility (EMC)

11/04

This machine has been designed in accordance with all relevant directives and standards. However, it may still generate electromagnetic disturbances that can affect other systems like telecommunications (telephone, radio, and television) or other safety systems. These disturbances can cause safety problems in the affected systems. Read and understand this section to eliminate or reduce the amount of electromagnetic disturbance generated by this machine.



This machine has been designed to operate in an industrial area. To operate in a domestic area it is necessary to observe particular precautions to eliminate possible electromagnetic disturbances. The operator must install and operate this equipment as described in this manual. If any electromagnetic disturbances are detected the operator must put in place corrective actions to eliminate these disturbances, if necessary with assistance from

Lincoln Electric.

WARNING

Provided that the public low voltage system impedance at the point of common coupling is lower than:

- 58 m Ω for the **QUICKMIG® 250**
- 59,9 m Ω for the **QUICKMIG® 300**

This equipment is compliant with IEC 61000-3-11 and IEC 61000-3-12 and can be connected to public low voltage systems. It is the responsibility of the installer or user of the equipment to ensure, by consultation with the distribution network operator if necessary, that the system impedance complies with the impedance restrictions.

Before installing the machine, the operator must check the work area for any devices that may malfunction because of electromagnetic disturbances. Consider the following.

- Input and output cables, control cables, and telephone cables that are in or adjacent to the work area and the machine.
- Radio and/or television transmitters and receivers. Computers or computer controlled equipment.
- Safety and control equipment for industrial processes. Equipment for calibration and measurement.
- Personal medical devices like pacemakers and hearing aids.
- Check the electromagnetic immunity for equipment operating in or near the work area. The operator must be sure that all equipment in the area is compatible. This may require additional protection measures.
- The dimensions of the work area to consider will depend on the construction of the area and other activities that are taking place.

Consider the following guidelines to reduce electromagnetic emissions from the machine.

- Connect the machine to the input supply according to this manual. If disturbances occur it may be necessary to take additional precautions such as filtering the input supply.
- The output cables should be as short as possible and positioned together as close as possible to each other. If possible connect the work piece to ground in order to reduce the electromagnetic emissions. The operator must check that connecting the work piece to ground does not cause problems or unsafe operating conditions for personnel and equipment.
- Shielding of cables in the work area can reduce electromagnetic emissions. This may be necessary for special applications.

WARNING

EMC classification of this product is class A in accordance with electromagnetic compatibility standard EN 60974-10 which means that the product is designed to be used in an industrial environment only.

WARNING











The Class A equipment is not intended for use in residential locations where the electrical power is provided by the public low-voltage supply system. There may be potential difficulties in ensuring electromagnetic compatibility in those locations, due to conducted as well as radiated disturbances.









WARNING

This equipment must be used by qualified personnel. Be sure that all installation, operation, maintenance and repair procedures are performed only by qualified person. Read and understand this manual before operating this equipment. Failure to follow the instructions in this manual could cause serious personal injury, loss of life, or damage to this equipment. Read and understand the following explanations of the warning symbols. Lincoln Electric is not responsible for damages caused by improper installation, improper care or abnormal operation.

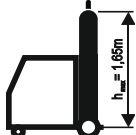
	<p>WARNING: This symbol indicates that instructions must be followed to avoid serious personal injury, loss of life, or damage to this equipment. Protect yourself and others from possible serious injury or death.</p>
	<p>READ AND UNDERSTAND INSTRUCTIONS: Read and understand this manual before operating this equipment. Arc welding can be hazardous. Failure to follow the instructions in this manual could cause serious personal injury, loss of life, or damage to this equipment.</p>
	<p>ELECTRIC SHOCK CAN KILL: Welding equipment generates high voltages. Do not touch the electrode, work clamp, or connected work pieces when this equipment is on. Insulate yourself from the electrode, work clamp and connected work pieces.</p>
	<p>ELECTRICALLY POWERED EQUIPMENT: Turn off input power using the disconnect switch at the fuse box before working on this equipment. Ground this equipment in accordance with local electrical regulations.</p>
	<p>ELECTRICALLY POWERED EQUIPMENT: Regularly inspect the input, electrode, and work clamp cables. If any insulation damage exists replace the cable immediately. Do not place the electrode holder directly on the welding table or any other surface in contact with the work clamp to avoid the risk of accidental arc ignition.</p>
	<p>ELECTRIC AND MAGNETIC FIELDS MAY BE DANGEROUS: Electric current flowing through any conductor creates electric and magnetic fields (EMF). EMF fields may interfere with some pacemakers and welders having a pacemaker shall consult their physician before operating this equipment.</p>
	<p>CE COMPLIANCE: This equipment complies with the European Community Directives.</p>
 <p><small>Optical radiation-emission Category 2 (EN 12198)</small></p>	<p>ARTIFICIAL OPTICAL RADIATION: According with the requirements in 2006/25/EC Directive and EN 12198 Standard, the equipment is a category 2. It makes mandatory the adoption of Personal Protective Equipment (PPE) having filter with a protection degree up to a maximum of 15, as required by EN169 Standard.</p>
	<p>FUMES AND GASES CAN BE DANGEROUS: Welding may produce fumes and gases hazardous to health. Avoid breathing these fumes and gases. To avoid these dangers the operator must use enough ventilation or exhaust to keep fumes and gases away from the breathing zone.</p>
	<p>ARC RAYS CAN BURN: Use a shield with the proper filter and cover plates to protect your eyes from sparks and the rays of the arc when welding or observing. Use suitable clothing made from durable flame-resistant material to protect you skin and that of your helpers. Protect other nearby personnel with suitable, non-flammable screening and warn them not to watch the arc nor expose themselves to the arc.</p>

	<p>WELDING SPARKS CAN CAUSE FIRE OR EXPLOSION: Remove fire hazards from the welding area and have a fire extinguisher readily available. Welding sparks and hot materials from the welding process can easily go through small cracks and openings to adjacent areas. Do not weld on any tanks, drums, containers, or material until the proper steps have been taken to insure that no flammable or toxic vapors will be present. Never operate this equipment when flammable gases, vapors or liquid combustibles are present.</p>
	<p>WELDED MATERIALS CAN BURN: Welding generates a large amount of heat. Hot surfaces and materials in work area can cause serious burns. Use gloves and pliers when touching or moving materials in the work area.</p>
	<p>CYLINDER MAY EXPLODE IF DAMAGED: Use only compressed gas cylinders containing the correct shielding gas for the process used and properly operating regulators designed for the gas and pressure used. Always keep cylinders in an upright position securely chained to a fixed support. Do not move or transport gas cylinders with the protection cap removed. Do not allow the electrode, electrode holder, work clamp or any other electrically live part to touch a gas cylinder. Gas cylinders must be located away from areas where they may be subjected to physical damage or the welding process including sparks and heat sources.</p>
	<p>A GAS CYLINDER can be used with this machine. In this case, place the gas cylinder on the back of the machine on the shelf intended for this and secure it by attaching it to the machine with chains. The height of the cylinder cannot exceed 1.65m.</p>
	<p>MOVING PARTS ARE DANGEROUS: There are moving mechanical parts in this machine, which can cause serious injury. Keep your hands, body and clothing away from those parts during machine starting, operating and servicing.</p>
	<p>SAFETY MARK: This equipment is suitable for supplying power for welding operations carried out in an environment with increased hazard of electric shock.</p>

The manufacturer reserves the right to make changes and/or improvements in design without upgrade at the same time the operator's manual.

Introduction

The welding machines **QUICKMIG® 250** and **QUICKMIG® 300** can be used for welding in below methods:

- GMAW
- FCAW
- SMAW

The complete package contains:

- Work lead with ground clamp – 3m,
- Gas hose – 2m,
- Drive roll V0.8/1.0 for solid wire (assembly in the wire feeder).

Recommended equipment, which can be bought by user, was mentioned in the chapter "Accessories".

Installation and Operator Instructions

Read this entire section before installation or operation of the machine.

Location and Environment

This machine will operate in harsh environments. However, it is important that simple preventative measures are followed to assure long life and reliable operation.

- Do not place or operate this machine on a surface with an incline greater than 10° from horizontal.
- Do not use this machine for pipe thawing.
- This machine must be located where there is free circulation of clean air without restrictions for air movement to and from the air vents. Do not cover the machine with paper, cloth or rags when switched on.
- Dirt and dust that can be drawn into the machine should be kept to a minimum.
- This machine has a protection rating of IP23. Keep it dry when possible and do not place it on wet ground or in puddles.
- Locate the machine away from radio controlled machinery. Normal operation may adversely affect the operation of nearby radio controlled machinery, which may result in injury or equipment damage. Read the section on electromagnetic compatibility in this manual.
- Do not operate in areas with an ambient temperature greater than 40°C.

Duty cycle and Overheating

The duty cycle of a welding machine is the percentage of time in a 10 minute cycle at which the welder can operate the machine at rated welding current.

Example: 60% duty cycle

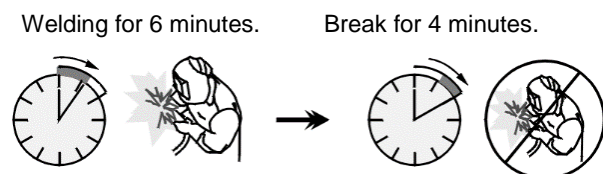

Excessive extension of the duty cycle will cause the thermal protection circuit to activate.

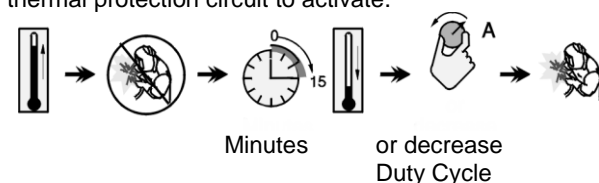

Input Supply Connection

WARNING

Only a qualified electrician can connect the welding machine to the supply network. Installation had to be made in accordance with the appropriate National Electrical Code and local regulations.

Check the input voltage, phase and frequency supplied to this machine before turning it on. Verify the connection of ground wires from the machine to the input source. The welding machine **QUICKMIG® 250**, **QUICKMIG® 300**, must be connected to a correctly installed plug-in socket with an earth pin. Input voltage is three-phase 400VAC, 50/60Hz. For more information about input supply refer to the technical specification section of this manual and to the rating plate of the machine.

Make sure that the amount of mains power available from the input supply is adequate for normal operation of the machine. The necessary delayed fuse (or circuit breaker with "D" characteristic) and cable sizes are indicated in the technical specification section of this manual.

WARNING

The welding machine can be supplied from a power generator of output power at least 30% larger than input power of the welding machine.

WARNING

When powering welder from a generator be sure to turn off welder first, before generator is shut down, in order to prevent damage to welder!

Output Connections

Refer to points [1], [3] and [4] of the figures below.

Controls and Operational Features

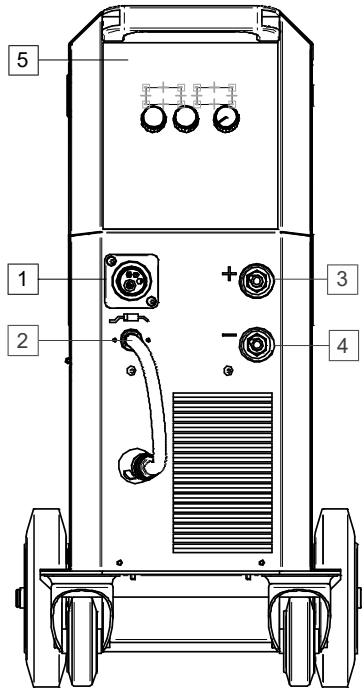

Figure 1

1. EURO Socket: For connecting a welding gun (for GMAW / FCAW processes).
2. Lead of Changing Polarity of EURO socket.
3. Positive Output Socket for the Welding Circuit: For connecting an electrode holder with lead / work lead depending on the require configuration. **+**
4. Negative Output Socket for the Welding Circuit: For connecting an electrode holder with lead / work lead depending on the require configuration. **-**
5. User Interface: See "User Interface" chapter.

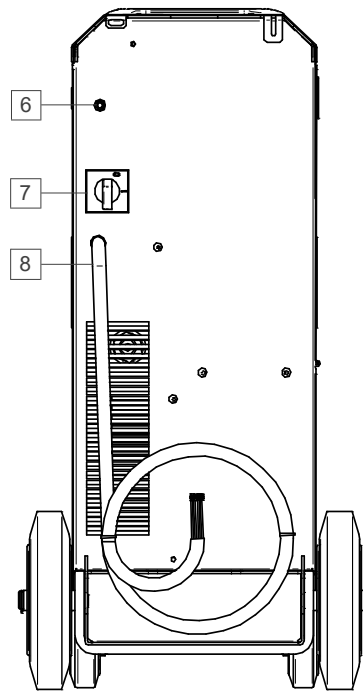

Figure 2

6. Gas Connector: Connection for gas line.
7. Power Switch ON/OFF (I/O): Controls the input power to the machine. Be sure the power source is connected to the mains supply before turning power on ("I").
8. Power Lead (5m): Connect the supply plug to the existing input cable that is rated for the machine as indicated in this manual, and conforms to all applicable standards. This connection shall be performed by a qualified person only.

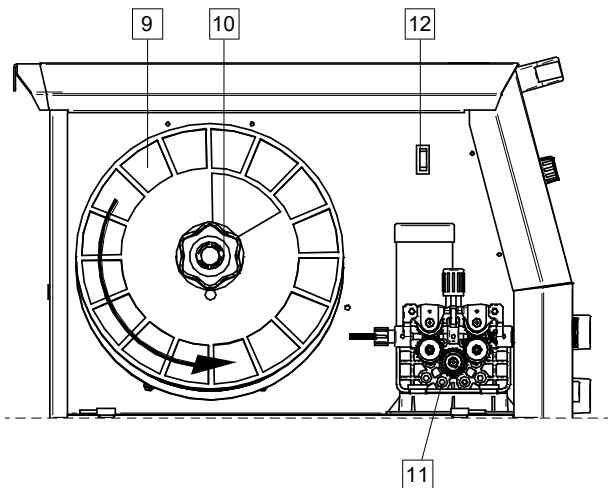

Figure 3

9. Spoiled Wire (for GMAW / FCAW): Not supplied as standard.
10. Wire Spool Holder: Maximum 15kg spools. Maximum 300mm diameter spools. Holder allows mounting plastic, steel and fiber spools onto 51 mm spindle.
Note: Plastic Brake Nut has a Left-hand thread.
11. Wire drive: 4-rolls wire drive.
12. Switch: Cold Inch / Gas Purge: This switch allows wire feeding (wire test) and gas flow (gas test) without switching on the output voltage.

User Interface

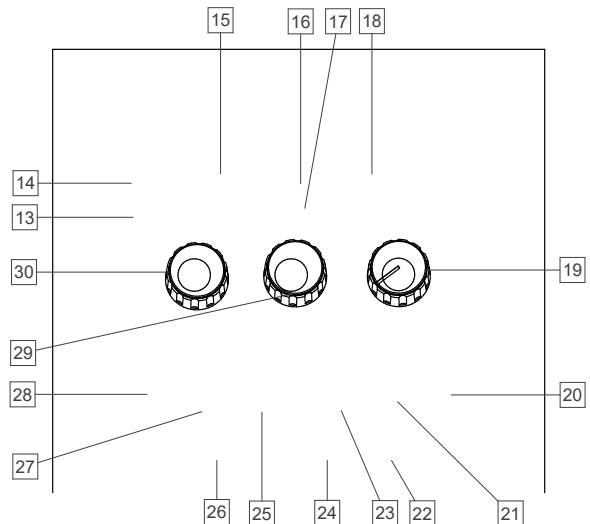





Figure 4

13. Thermal Overload Indicator: It indicates that the machine is overloaded or that the cooling is not sufficient. Displays show: "ALA ot" = Alarm Over Temperature message.
14. Input Power Indicator: This LED lights up when the welding machine is ON and is ready to work.
15. Left Display: Shows wire feed speed or welding current. During welding shows the actual welding current value.
16. Output Current LED Indicator: Informs that the Left Display shows the output current in ampere.
17. Wire Feed Speed LED Indicator: Informs that the Left Display shows the wire feed speed in m/min.
18. Right Display: Depending on the selected function and the welding program shows the welding voltage in volts or value of Arc Force. During welding shows the actual output welding voltage.
19. Inductance Control: Adjusts the hardness of the arc. A low value (1-4) makes the arc harder (more spatter), while a high value (8-10) produces a softer arc (less spatter). Adjustment range: 0 to +10.





20. **Wire Diameter or Manual Mode Selection Button:** Sets the diameter of the welding wire for Synergic Mode or choose Manual Mode.

Process	Symbol	Description
	0.6	Available wire diameter depends on choosing gas shielding type, type of wire and welding wire material.
	0.8	
	0.9	
	1.0	
	1.2	
		The machine works in Manual mode. Welding parameters (wire feed speed and voltage) are selected by the user.

21. **Wire Material Selection Button:** sets the type of wire materials (for Synergic Mode only):

Process	Symbol	Description
	Fe	Steel
	Al	Aluminum
	SS	Stainless steel





22. **Burnback Time Selection Button** – for Synergic and Manual Mode, allow to choose and set burnback time:

Process	Symbol	Description
		Burnback Time - amount of time that the welding is continued after the wire stops feeding. It prevents the wire from sticking in the puddle and prepares the end of the wire for the next arc ignition.
		<ul style="list-style-type: none"> Regulation range: from 0,02 to 0,25 seconds.
		
		

23. **Welding Wire Type Selection Button:** Set welding wire type (for Synergic Mode only):

Process	Symbol	Description
	Solid	<ul style="list-style-type: none"> For Synergic Mode only Gas shield required
	Flux-Cored	



24. **Run-In WFS Button:** Allow to show and set the Run-in wire feed speed value (for Synergic and Manual Mode):

Process	Symbol	Description
		Run-in WFS – sets the wire feed speed from the time the trigger is pulled until an arc is established.
		<ul style="list-style-type: none"> Adjust range: from 20 to 100 percent of the WFS value. When Run-In value is more than max WFS, machine keep max WFS.
		
		



25. **Gas Selection Button:** Enables the selection of the type of shielding gas (for Synergic Mode only).

Process	Symbol	Description
	CO ₂	To choose gas shielding.
	MIX	
	Ar	



26. **Selection Button to Display Workpoint as WFS or A:** Allows to change the operating point display as wire feed speed (WFS) in [m/min] or as an output current value in [A]. Only available in synergic mode.

Process	Symbol	Description
		Workpoint values are displayed in m/min.
	A	Workpoint values are displayed as an amperage [A].







27. Torch Trigger Mode Button (2-Step/4-Step): Change the function of the torch trigger.

Process	Symbol	Description
		2-Step trigger operation turns welding on and off as direct response to the trigger. Welding process starts when the torch trigger is press.
		4-Step mode allows to continue welding, when the torch trigger is released. To stop welding, the torch trigger should be pressed again. 4-step model facilitates to make long welds.

28. Welding Process Selection Button: Allow to choose the welding process:

Symbol	Description
	GMAW/FACW welding mode.
	SMAW welding mode.

29. The Center Control: Sets the value shown on the right display. Depending on welding processes or selected function can be set:

Process	Symbol	Description
	V	The welding voltage (also during welding).
		Burnback Time • Adjust range: from 0.02 to 0.25 seconds
		Run-in WFS • Adjust range: from 20 to 100 percent of the WFS value.
		ARC FORCE, the output current is temporarily increased to clear short circuit connections between the electrode and the workpiece. Lower values will provide less short circuit current and a softer arc. Higher settings will provide a higher short circuit current, a more forceful arc and possibly more spatter. • Adjust range: from 0 to 100.

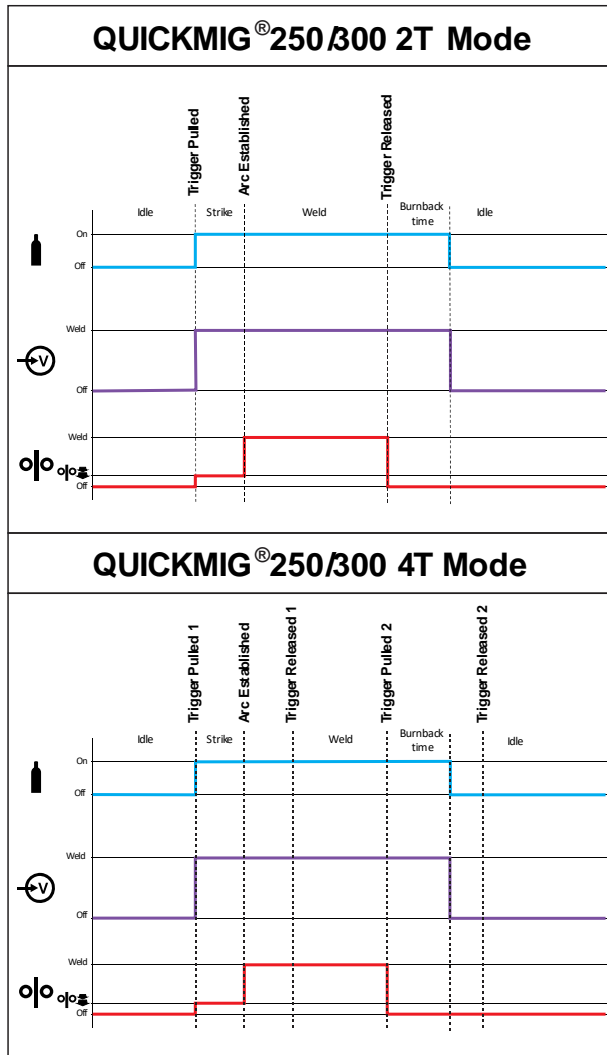



Figure 5

30. Left Control: Sets the value shown on the left display. Depending on welding process can be set:

Process	Mark	Description
	o/o	Workpoint values are displayed in m/min.
	A	Workpoint values are displayed as an amperage [A].

Welding SMAW Process

QUICKMIG® 250, QUICKMIG® 300 does not include the electrode holder with lead necessary for SMAW welding, but the one can be purchased separately.

Procedure of begin welding of SMAW process:

- First turn the machine off.
- Determine the electrode polarity for the electrode to be used. Consult the electrode data for this information.
- Depending on the polarity of using electrode, connect the work lead and the electrode holder with lead to output socket [3] or [4] and lock them. See the Table 1.

Table 1.

		Output socket	
POLARITY	DC (+)	The electrode holder with lead to SMAW	[3] +
		Work lead	[4] -
	DC (-)	The electrode holder with lead to SMAW	[3] -
		Work lead	[4] +

- Connect the work lead to the welding piece with the work clamp.
- Install the proper electrode in the electrode holder.
- Turn the welding machine on.
- Set welding mode to SMAW.
- Set the welding parameters.
- The welding machine is now ready to weld.
- By applying the principle of occupational health and safety at welding, welding can be begun.

User can set functions:

- The welding current
- Arc dynamics ARC FORCE

Welding GMAW, FCAW Process

QUICKMIG® 250, QUICKMIG® 300 can be used to welding GMAW, FCAW-GS, FCAW-SS process.

NOTE: Welding FCAW-SS process is possible in Manual Mode only.

In **QUICKMIG® 250, QUICKMIG® 300** can be set:

- Wire Feed Speed, WFS
- The welding voltage
- Burnback Time
- Run-in WFS
- 2-Step/4-Step
- Polarization DC+/DC-
- Inductance

Preparation the Machine for Welding GMAW and FCAW Process.

Procedure of welding in GMAW or FCAW process:

- Determine the wire polarity for the wire to be used. Consult the wire data for this information.
- Connect output the gas-cooled gun to GMAW / FCAW process to Euro Socket [1].
- Depending on the using wire, connect the work lead to output socket [3] or [4]. See the Table 2.

Table 2

		Output socket	
POLARITY	DC (+)	Lead of Changing Polarity [2]	[3] +
		Work lead	[4] -
	DC (-)	Lead of Changing Polarity [2]	[3] -
		Work lead	[4] +



- Connect the work lead to the welding piece with the work clamp.
- Install the proper wire.
- Install the proper drive roll.
- Make sure, if it is needed (GMAW, FCAW-GS processes), that the gas shield has been connected.
- Turn the machine on.
- Push the Cold Inch Switch [12] to feed the wire through the gun liner until the wire comes out of the threaded end.
- Install a proper contact tip.
- Check gas flow with Gas Purge Switch [12] – GMAW and FCAW processes.
- Close the left side panel.
- Set welding mode to GMAW
- The welding machine is now ready to weld.
- By applying the principle of occupational health and safety at welding, welding can be begun.

Welding GMAW Process in synergic mode

In synergic mode, the welding load voltage is not set by user. The correct welding load voltage will set by the machine's software.

The optimum output welding voltage is automatically set by the machine when changing the wire feed speed m/min or the output current value in A, depending on the selected workpoint. Table 3 below show all available synergic welding programs.

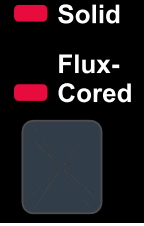
Table 3

Wire Diameter	Wire type	Wire Material	Gas Type
			
0.6	Solid	Fe	CO ₂
0.8	Solid	Fe	CO ₂
0.9	Solid	Fe	CO ₂
1.0	Solid	Fe	CO ₂
1.2	Solid	Fe	CO ₂
0.6	Solid	Fe	MIX
0.8	Solid	Fe	MIX
0.9	Solid	Fe	MIX
1.0	Solid	Fe	MIX
1.2	Solid	Fe	MIX
0.8	Solid	Ss	MIX
0.9	Solid	Ss	MIX
1.0	Solid	Ss	MIX
1.2	Solid	Ss	MIX
0.8	Flux-Cored	Fe	CO ₂
0.9	Flux-Cored	Fe	CO ₂
1.0	Flux-Cored	Fe	CO ₂
1.2	Flux-Cored	Fe	CO ₂
0.8	Flux-Cored	Fe	MIX
0.9	Flux-Cored	Fe	MIX
1.0	Flux-Cored	Fe	MIX
1.2	Flux-Cored	Fe	MIX
1.0	Solid	Al	Ar
1.2	Solid	Al	Ar

Loading the Electrode Wire

Depending on the type of wire spool it can be installed on the wire spool support without adapter or installed with use applicable adapter that must be purchased separately (see "Accessories" chapter).

WARNING

Turn the input power OFF at the welding power source before installation or changing a wire spool.

- Turn the machine off.
- Open the side cover of the machine.
- Unscrew the locking nut of the sleeve.
- Load the spool with the wire on the sleeve such that the spool turns anticlockwise when the wire is fed into the wire feeder.
- Make sure that the spool locating pin goes into the fitting hole on the spool.
- Screw in the fastening cap of the sleeve.
- Put on the wire roll using the correct groove corresponding to the wire diameter.
- Free the end of the wire and cut off the bent end making sure it has no burr.
- The device is adapted to the spool max. 300mm

WARNING

Sharp end of the wire can hurt.

- Rotate the wire spool anticlockwise and thread the end of the wire into the wire feeder as far as the Euro socket.
- Adjust force of pressure roll of the wire feeder properly.

Adjustments of Brake Torque of Sleeve

To avoid spontaneous unrolling of the welding wire the sleeve is fitted with a brake.

Adjustment is carried by rotation of its Allen screw M8, which is placed inside of the sleeve frame after unscrewing the fastening cap of the sleeve.

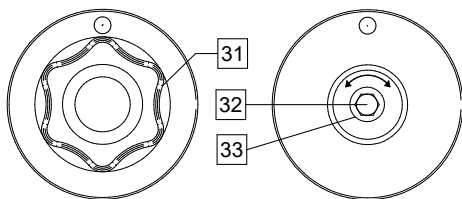

Figure 6

31. Fastening cap.
32. Adjusting Allen screw M8.
33. Pressing spring.

Turning the Allen screw M8 anticlockwise increases the spring tension and you can increase the brake torque

Turning the Allen screw M8 clockwise decreases the spring tension and you can decrease the brake torque.

After finishing of adjustment, you should screw in the fastening cap again.

Adjusting of Force of Pressure Roll Force

The pressure arm controls the amount of force the drive rolls exert on the wire.

Pressure force is adjusted by turning the adjustment nut clockwise to increase force, counterclockwise to decrease force. Proper adjustment of pressure arm gives the best welding performance.

WARNING

If the roll pressure is too low the roll will slide on the wire. If the roll pressure is set too high the wire may be deformed, which will cause feeding problems in the welding gun. The pressure force should be set properly. Decrease the pressure force slowly until the wire just begins to slide on the drive roll and then increase the force slightly by turning of the adjustment nut by one turn.

Inserting Electrode Wire into Welding Torch

- Turn the welding machine off.
- Depending on welding process, connect the proper gun to the euro socket, the rated parameters of the gun and of the welding machine should be matched.
- Remote the nozzle from the gun and contact tip or protection cap and contact tip. Next, straighten the gun out flat.
- Turn the welding machine on.
- Push the Cold Inch Switch [12] to feed the wire through the gun liner until the wire comes out of the threaded end.
- When switch is released spool of wire should not unwind.
- Adjust wire spool brake accordingly.
- Turn the welding machine off.
- Install a proper contact tip.
- Depending on the welding process and the type of the gun, install the nozzle (GMAW process) or protection cap (FCAW- process).

WARNING

Take precaution to keep eyes and hands away from the end of the gun while the wire is being come out of the threaded end.

Changing Driving Rolls

WARNING

Turn the input power off of the welding power source before installation or changing drive rolls.

QUICKMIG® 250, QUICKMIG® 300 is equipped with drive roll V0.8/V1.0 for steel wire. For others wire type or / and diameter, the proper drive rolls kit you can find in "Accessories" chapter and follow instructions:

- Turn the input power OFF.
- Unlock 2 rolls by turning 2 Quick-Change Carrier Gear [38].
- Release the pressure roll levers [39].
- Change the drive rolls [37] corresponding to the used wire.

WARNING

Be sure that the gun liner and contact tip are also sized to match the selected wire size.

WARNING

For wires with the diameter larger than 1.6mm, the following parts have to be changed:

- The guide tube of the feeding console [35] and [36].
- The guide tube of the Euro Socket [34].
- Lock 2 new rolls by turning 2 Quick-Change Carrier Gear [38].
- Insert the wire through the guide tube, over the roller and through the guide tube of Euro Socket into liner of gun. The wire can be pushed into the liner manually for a few centimeters, and should feed easily and without any force.
- Lock the pressure roll lever [39].

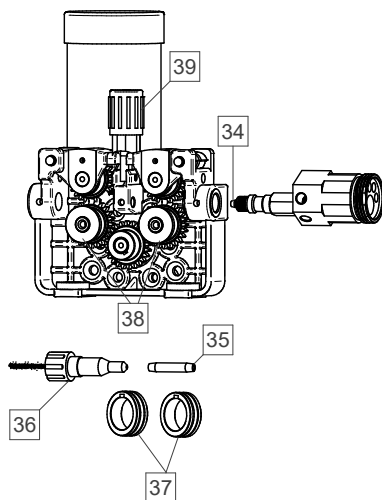

Figure 7

Gas Connection

A gas cylinder must be installed with a proper flow regulator. Once a gas cylinder with a flow regulator has been securely installed, connect the gas hose from the regulator to the machine gas inlet connector.

WARNING

The welding machine supports all suitable shielding gases including carbon dioxide, argon and helium at a maximum pressure of 5,0 bars.

Transport & Lifting



WARNING

Falling equipment can cause injury and damage to unit.

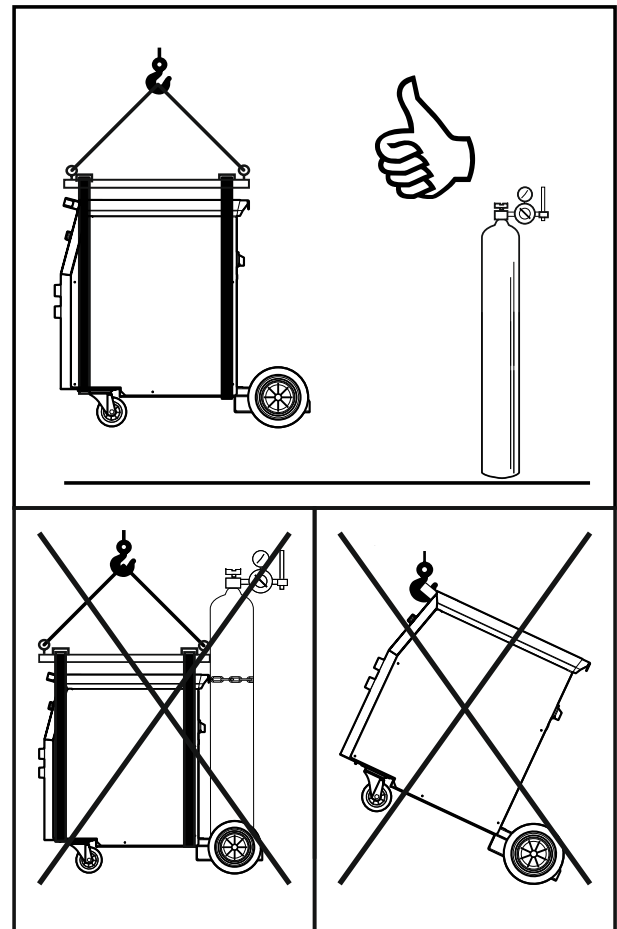

Figure 8

During transportation and lifting with a crane, adhere to the following rules:

- Power source does not include the eye bolt which can be used to transport or lifting the machine.
- To lift use of suitable lifting equipment capacity.
- To lifting and transport use a travers and minimum two belts.
- Lift only power source without gas cylinder, cooler and wire feeder, or/and any other accessories.

Maintenance

WARNING

For any repair operations, modifications or maintenances, it is recommended to contact the nearest Technical Service Center or Lincoln Electric. Repairs and modifications performed by unauthorized service or personnel will cause, that the manufacturer's warranty will become null and void.

Any noticeable damage should be reported immediately and repaired.

Routine maintenance (everyday)

- Check condition of insulation and connections of the work leads and insulation of power lead. If any insulation damage exists replace the lead immediately.
- Remove the spatters from the welding gun nozzle. Spatters could interfere with the shielding gas flow to the arc.
- Check the welding gun condition: replace it, if necessary.
- Check condition and operation of the cooling fan. Keep clean its airflow slots.

Periodic maintenance (every 200 working hours but at list once every year)

- Perform the routine maintenance and, in addition:
- Keep the machine clean. Using a dry (and low pressure) airflow, remove the dust from the external case and from the cabinet inside.
- If it is required, clean and tighten all weld terminals.

The frequency of the maintenance operations may vary in accordance with the working environment where the machine is placed.

WARNING

Do not touch electrically live parts.

WARNING

Before the case of welding machine will be removed, the welding machine had to be turned off and the power lead had to be disconnected from mains socket.

WARNING

Mains supply network must be disconnected from the machine before each maintenance and service. After each repair, perform proper tests to ensure safety.

Customer Assistance Policy

The business of The Lincoln Electric Company is manufacturing and selling high quality welding equipment, consumables, and cutting equipment. Our challenge is to meet the needs of our customers and to exceed their expectations. On occasion, purchasers may ask Lincoln Electric for advice or information about their use of our products. We respond to our customers based on the best information in our possession at that time. Lincoln Electric is not in a position to warrant or guarantee such advice, and assumes no liability, with respect to such information or advice. We expressly disclaim any warranty of any kind, including any warranty of fitness for any customer's particular purpose, with respect to such information or advice. As a matter of practical consideration, we also cannot assume any responsibility for updating or correcting any such information or advice once it has been given, nor does the provision of information or advice create, expand or alter any warranty with respect to the sale of our products

Lincoln Electric is a responsive manufacturer, but the selection and use of specific products sold by Lincoln Electric is solely within the control of, and remains the sole responsibility of the customer. Many variables beyond the control of Lincoln Electric affect the results obtained in applying these types of fabrication methods and service requirements.

Subject to Change – This information is accurate to the best of our knowledge at the time of printing. Please refer to www.lincolnelectric.com for any updated information.

THERMAL PROTECTION

Thermal detection devices protect the machine from excessive operating temperatures. Excessive temperatures may be caused by a lack of cooling air or operating the machine beyond the duty cycle and output rating. If excessive operating temperatures should occur, the yellow LED will light and the detection device will prevent output voltage or current.

These detection devices are self-resetting once the machine cools sufficiently. If the thermostat shutdown was caused by excessive output or duty cycle and the fan is operating normally, the power switch may be left on and the reset should occur within a 15 minute period. If the fan is not turning or the air intake louvers were obstructed, then the power must be switched off and the fan problem or air obstruction must be corrected.

MAJOR COMPONENTS LOCATION

QUICKMIG 250 & 300

- | | |
|-------------------|------------------------|
| 1. Fans | 8. Wire drive assembly |
| 2. EMC filter | 9. Rectification Board |
| 3. Display Board | 10. Auxiliary Board |
| 4. Inverter Board | 11. Control Board |
| 5. Gas solenoid | 12. Main Transformer |
| 6. ON/OFF switch | 13. Output Choke |
| 7. Reel support | |

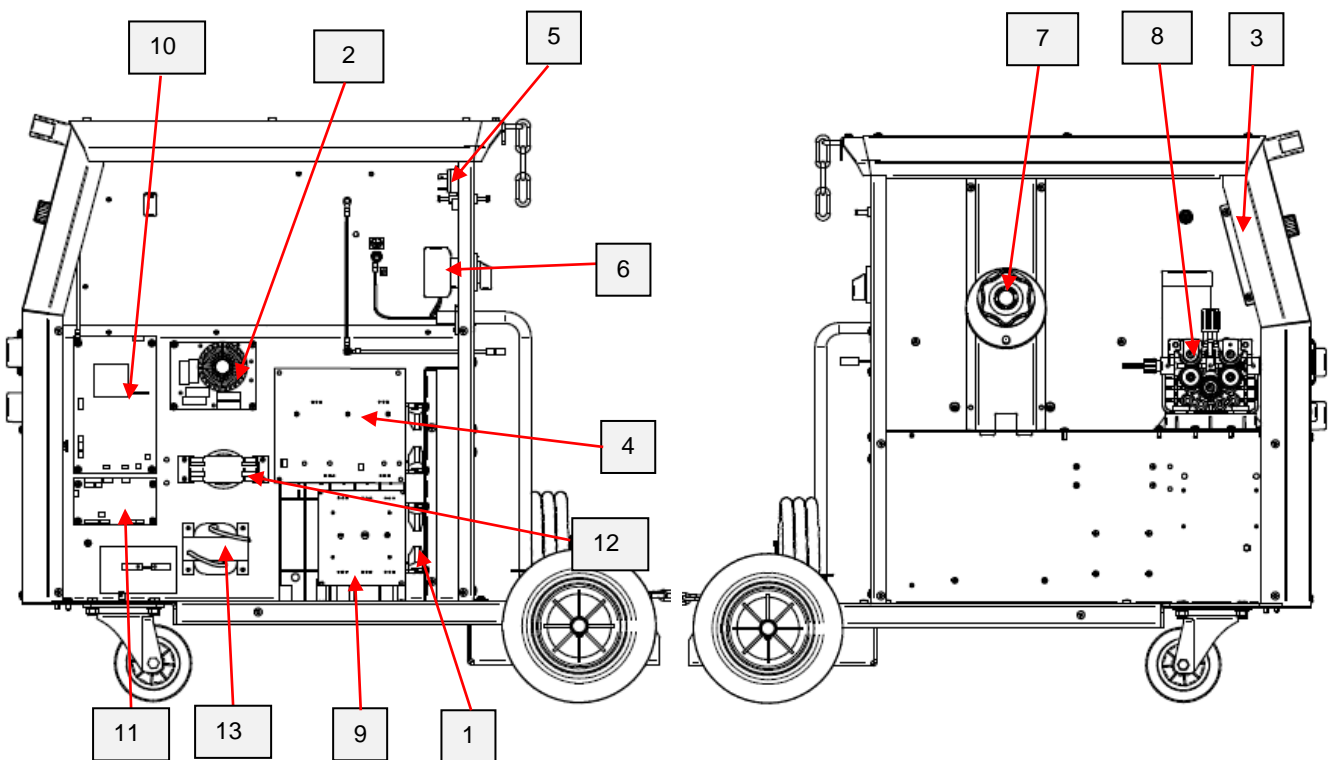

OVERLOAD PROTECTION

QUICKMIG 250 & 300 are electrically protected from producing higher than normal output current. An electronic protection circuit limits the current to within the capabilities of the machine.

THERMAL PROTECTION

There are thermal devices located on the power board. They protect the machine from excessive operating temperature. Excessive temperature may be caused by a lack of cooling air or by operating the machine beyond

the duty cycle and output rating. If excessive operating temperature should occur, the Thermal Overload indicator on the front panel, will turn ON and the thermostat will prevent output current.

The thermal protection devices are self-resetting once the machine cools sufficiently. If the shutdown was caused by excessive output or duty cycle and the fan is operating normally, the power switch may be left on and the reset should occur within about 8-10 minutes period. If the fan is not turning or the air intake louvers are obstructed, the input power must be removed and the fan problem or air obstruction must be corrected.

INSULATED GATE BIPOLAR TRANSISTOR (IGBT) OPERATION

An IGBT is a type of transistor. IGBTs are semiconductors well suited for high frequency switching and high current applications. Drawing A shows an IGBT in a passive mode. There is no gate signal, zero volts relative to the source, and therefore, no current flow. The drain terminal of the IGBT may be connected to a voltage supply; but since there is no conduction the circuit will not supply current to components connected to the source. The circuit is turned off

like a light switch in the OFF position.

Drawing B shows the IGBT in an active mode. When the gate signal, a positive DC voltage relative to the source, is applied to the gate terminal of the IGBT, it is capable of conducting current. A voltage supply connected to the drain terminal will allow the IGBT to conduct and supply current to circuit components coupled to the source. Current will flow through the conducting IGBT to downstream components as long as the positive gate signal is present. This is similar to turning ON a light switch.

IGBT

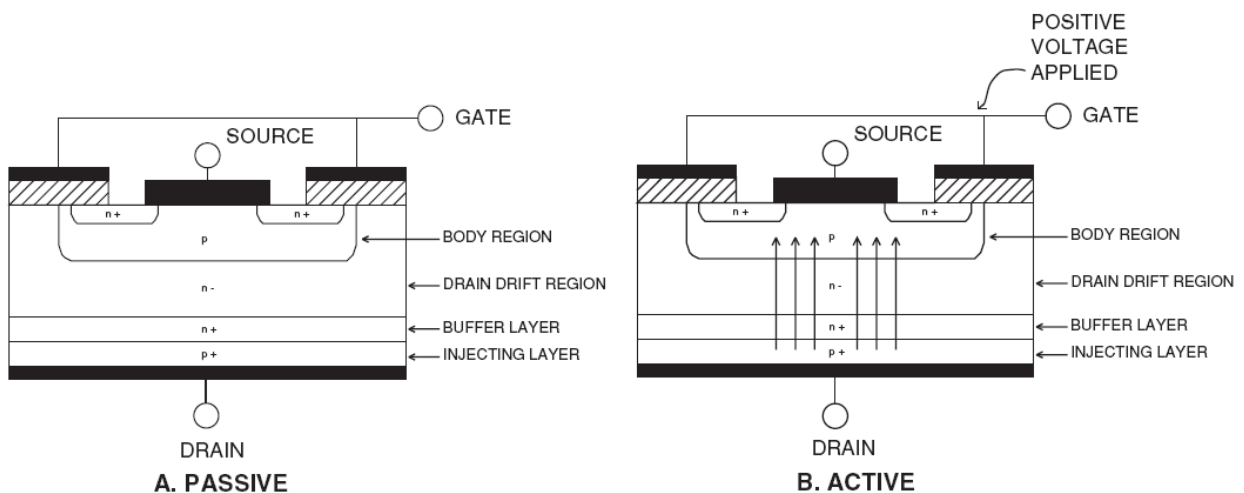

TROUBLESHOOTING AND REPAIR SECTION

- How to use troubleshooting Guide
- Troubleshooting Guide
- Side panels removal and capacitor discharge procedure

HOW TO USE TROUBLESHOOTING GUIDE

Service and repair should be performed by only Lincoln Electric Factory Trained Personnel. Unauthorized repairs performed on this equipment may result in danger to the technician and machine operator and will invalidate your factory warranty. For your safety and to avoid Electrical Shock, please observe all safety notes and precautions detailed throughout this manual.

.....

This Troubleshooting Guide is provided to help you locate and repair possible machine malfunctions. Simply follow the three-step procedure listed below.

Step 1. LOCATE PROBLEM (SYMPTOM). Look under the column labeled "PROBLEMS". This column describes possible symptoms that the machine may exhibit. Find the listing that best describes the symptom that the machine is exhibiting. Symptoms are grouped into three main categories: Output Problems, Function Problems, and LED Function Problems.

Step 2. PERFORM EXTERNAL TESTS. The second column, labeled "CHECKS", lists the obvious external possibilities that may contribute to the machine symptom. Perform these tests/checks in the order listed. In general, these tests can be conducted without removing the case wrap-around cover.

Step 3. PERFORM COMPONENT TESTS. The last column, labeled "RECOMMENDED COURSE OF ACTION " lists the most likely components that may have failed in your machine. It also specifies the appropriate test procedure to verify that the subject component is either good or bad. If there are a number of possible components, check the components in the order listed to eliminate one possibility at a time until you locate the cause of your problem.

All of the referenced test procedures referred to in the Troubleshooting Guide are described in detail at the end of this chapter. Refer to the Troubleshooting and Repair Table of Contents to locate each specific Test Procedure. All of the referred to test points, components, terminal strips, etc., can be found on the referenced electrical wiring diagrams and schematics. Refer to the Wiring Diagrams Section Table of Contents to locate the appropriate diagram.

WARNING



ELECTRIC SHOCK can kill

- Have an electrician install and service this equipment
- Turn the input power off at the fuse box before working on equipment
- Do not touch electrically hot parts
- Prior to performing preventive maintenance, perform the following capacitor discharge procedure to avoid electric shock

Sometimes machine failures appear to be due to PC board failures. These problems can sometimes be traced to poor electrical connections. To avoid problems when troubleshooting and replacing PC boards, please use the following procedure:

1. Determine to the best of your technical ability that the PC board is the most likely component causing the failure symptom.
2. Check for loose connections at the PC board to assure that the PC board is properly connected.
3. If the problem persists, replace the suspect PC board using standard practices to avoid static electrical damage and electrical shock.

4. Test the machine to determine if the failure symptom has been corrected by the replacement PC board.

NOTE: Allow the machine to heat up so that all electrical components can reach their operating temperature.

5. Remove the replacement PC board and substitute it with the original PC board to recreate the original problem.
 - If the original problem does not reappear by substituting the original board, then the PC board was not the problem. Continue to look for bad connections in the control wiring harness, junction blocks, and terminal strips.
 - If the original problem is recreated by the substitution of the original board, then the PC board was the problem. Reinstall the replacement PC board and test the machine.
6. Always indicate that this procedure was followed when warranty reports are to be submitted.

NOTE: Following this procedure and writing on the warranty report, "INSTALLED AND SWITCHED PC BOARDS TO VERIFY PROBLEM," will help avoid denial of legitimate PC board warranty claims.

TROUBLESHOOTING

!! WARNING !! BEFORE CONNECT POWER SUPPLY, MAKE A CAREFUL VISUAL INSPECTION INSIDE THE MACHINE, CHECK ALL THE BOARDS AND HARNESES.

PROBLEMS / SYMPTOMS	POSSIBLE AREAS OF MISADJUSTMENT(S)	CHECKS & RECOMMENDED COURSE OF ACTION
THE INPUT FUSES REPEATEDLY FAIL OR THE INPUT CIRCUIT BREAKERS KEEP TRIPPING.	<ul style="list-style-type: none"> • MAKE SURE THE INPUT FUSES OR CIRCUIT BREAKERS ARE PROPERLY SIZED. 	<ul style="list-style-type: none"> • PERFORM THE INPUT RECTIFIER BRIDGE • PERFORM THE MAIN BOARD TEST
THE MACHINE IS "DEAD". NO LIGHTS, NO OUTPUT, THE MACHINE APPEARS TO HAVE NO INPUT POWER.	<ul style="list-style-type: none"> • MAKE SURE THE INPUT POWER SWITCH IS IN THE ON POSITION. • CHECK THE MAIN INPUT FUSES OR BREAKERS TO MAKE SURE ALL THREE PHASES OF THE CORRECT INPUT POWER ARE PRESENT AT THE MACHINE. 	<ul style="list-style-type: none"> • CHECK THE INPUT SWITCH FOR PROPER OPERATION. ALSO CHECK THE ASSOCIATED LEADS FOR LOOSE OR FAULTY CONNECTIONS. SEE WIRING DIAGRAM. • PERFORM THE AUXILIARY POWER BOARD TEST
THERMAL INDICATOR IS ON	<ul style="list-style-type: none"> • INSUFFICIENT VENTILATION • AMBIENT TEMPERATURE IS TOO HIGH • EXCEEDING THE RATED DUTY CYCLE 	<ul style="list-style-type: none"> • IMPROVE THE VENTILATION/REMOVE ANY OBSTRUCTION FROM THE VENTILATION GRIDS • IT WILL AUTOMATICALLY RECOVER WHEN THE TEMPERATURE REDUCES
WELDING FEEDING NOT WORKING	<ul style="list-style-type: none"> • UI OR AUX. POWER PCB IS BROKEN • CONTACT TIP IS MELTED OR LINER IS OBSTRUCT • DRIVE ROLL PRESSURE IS NOT SUFFICIENT 	<ul style="list-style-type: none"> • VERIFY AND REPLACE THE UI OR AUX.POWER PCB • CHANGE THE CONTACT TIP OR THE TORCH LINER • INCREASE TENSION ON DRIVE ROLL
COOLING FAN NOT WORKING	<ul style="list-style-type: none"> • FAN BROKEN • FAN HARNESS WIRE BROKEN OR DISCONNECTED • AUX. POWER BOARD FAULTY 	<ul style="list-style-type: none"> • REPLACE THE FAN • CHECK THE FAN HARNESS • CHECK AND REPLACE IF NECESSARY THE AUX. POWER BOARD
ARC IS NOT STABLE AND TOO MUCH SPATTERS	<ul style="list-style-type: none"> • TOO LARGE CONTACT TIP MAKES THE CURRENT UNSTEADY • TOO THIN POWER CABLE MAKES THE INPUT VOLTAGE UNSTABLE • TOO LOW INPUT VOLTAGE • WIRE FEEDING RESISTANCE IS TOO LARGE (DRIVE ROLLS TOO THIGHT) 	<ul style="list-style-type: none"> • CHANGE TO PROPER CONTACT TIP AND /OR DRIVE ROLL • CHANGE THE POWER CABLE • CORRECT THE INPUT VOLTAGE OR MAKE SURE TO USE A CORRECT CROSS SECTION FOR THE EXTENSION IF USED. • CLEAN OR REPLACE THE LINER AND KEEP THE GUN CABLE STRAIGHT
ARC WILL NOT START	<ul style="list-style-type: none"> • WORK CABLE BROKEN • WORK PIECE HAS GREASY, DIRTY, RUSTY OR PAINTED 	<ul style="list-style-type: none"> • CONNECT/REPAIR WORK CABLE • CLEAN THE WORK PIECE, ENSURE GOOD ELECTRICAL CONTACT BETWEEN WORK CLAMP AND JOB
NO SHIELDING GAS	<ul style="list-style-type: none"> • TORCH IS NOT CONNECTED OR DAMAGED PROPERLY • GAS PIPE IS CHOKED • GAS HOSE BROKEN/CUTTED 	<ul style="list-style-type: none"> • RE-CONNECT THE TORCH OR REPLACE IT • CHECK GAS CIRCUIT • REPAIR OR REPLACE GAS HOSE

SIDE PANELS REMOVAL AND DC BUS CAPACITORS DISCHARGE PROCEDURE

WARNING

Service and repair should be performed only by Lincoln Electric factory trained personnel. Unauthorized repairs performed on this equipment may result in danger to the technician or machine operator and will invalidate your factory warranty. For your safety and to avoid electrical shock, please observe all safety notes and precautions detailed throughout this manual.

If for any reason you do not understand the test procedures or are unable to perform the test/repairs safely, contact your Local Lincoln Electric Service Department for electrical troubleshooting assistance before you proceed.

.....

DESCRIPTION

This procedure will aid the technician in the removal and replacement of the left and right metal panels and discharging the DC Bus capacitors making it safe for the technician to work on the machine.

MATERIALS NEEDED

Torx T25 wrench

QUICKMIG 250 & 300 – SIDE PANELS & COVER REMOVAL

NOTE: to remove the side panels is it not necessary to remove the cover

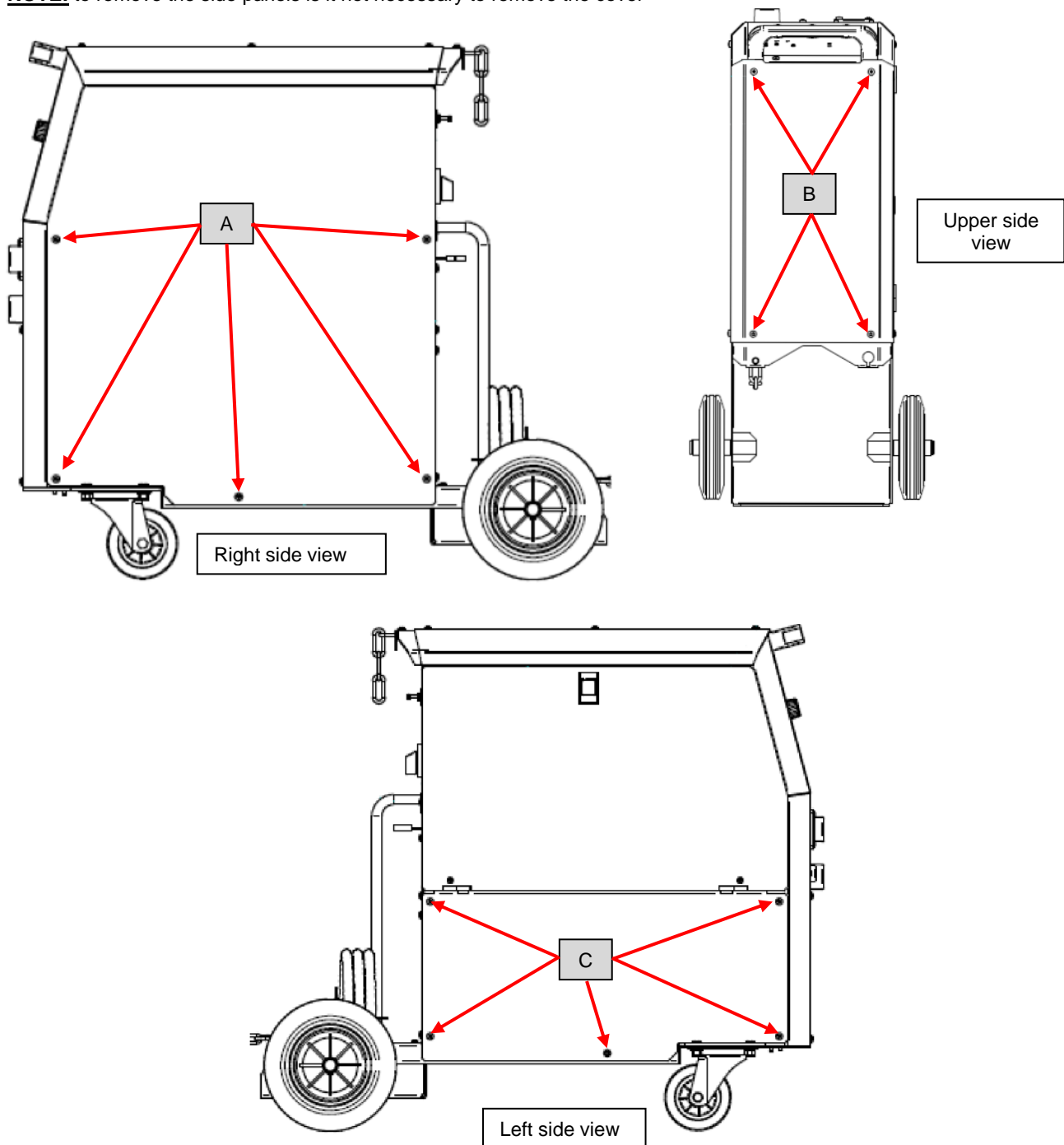

Necessary tool:

- Torx T25 wrench

Procedure:

1. Turn ON/OFF switch to OFF position.
2. Disconnect Input Power from the machine!
3. Remove the 9 screws (A) & (B) from the right panel and upper side panel. **See above pictures**
4. Remove the 5 screws (C) from the left low side panel. **See above pictures**
5. Remove carefully the left and right panels

Follow the next session to **perform the discharge procedure**

DISCHARGE PROCEDURE

WARNING



ELECTRIC SHOCK can kill

Have an electrician install and service this equipment
Turn the input power off at the fuse box before working on equipment

Do not touch electrically hot parts

Prior to performing preventive maintenance, perform the following capacitor discharge procedure to avoid electric shock.

DC BUS CAPACITOR DISCHARGE PROCEDURE

1. Remove main input power to the QUICKMIG 250 & 300
2. Remove the right side panel following the case removal procedure available in this Service manual.

3. Obtain a high resistance and high wattage resistor (25-1000 ohms and 25 watts minimum). This resistor is NOT supplied with the machine. NEVER USE A SHORTING STRAP FOR THIS PROCEDURE.
4. For all the following operations **use electrically insulated gloves.**
5. Locate the two terminals **DC+** and **DC -** on the Switch Board on the right side of the machine (**See Figure 1**).
6. Using insulated pliers hold the body of the resistor and connect the resistor leads across one of the three DC BUS capacitors. Hold the resistor in place for 10 seconds. DO NOT TOUCH CAPACITOR TERMINALS WITH YOUR BARE HANDS.
7. Check again the voltage across the DC BUS Capacitors; voltage should be zero. If any voltage remains, repeat the discharge procedure.

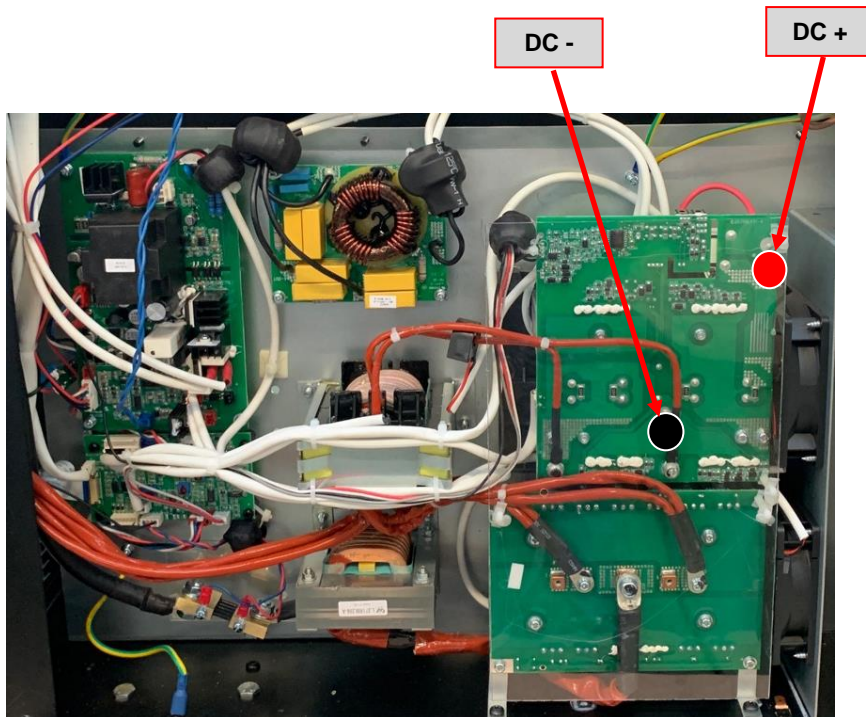

Figure 1

INVERTER BOARD RESISTANCE TEST

WARNING

Service and repair should be performed by only Lincoln Electric factory trained personnel. Unauthorized repairs performed on this equipment may result in danger to the technician or machine operator and will invalidate your factory warranty. For your safety and to avoid electrical shock, please observe all safety notes and precautions detailed throughout this manual. If for any reason you do not understand the test procedures or are unable to perform the test/repairs safely, contact your Local Lincoln Electric Service Department for electrical troubleshooting assistance before you proceed.

.....

TEST DESCRIPTION

This test will determine if the Inverter board has failed.

MATERIALS NEEDED

Volt / Ohmmeter
Machine Wiring Diagram

INVERTER BOARD RESISTANCE TEST (continued)

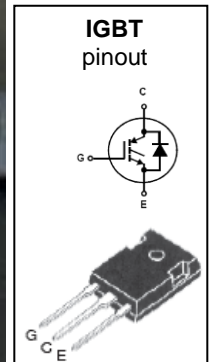
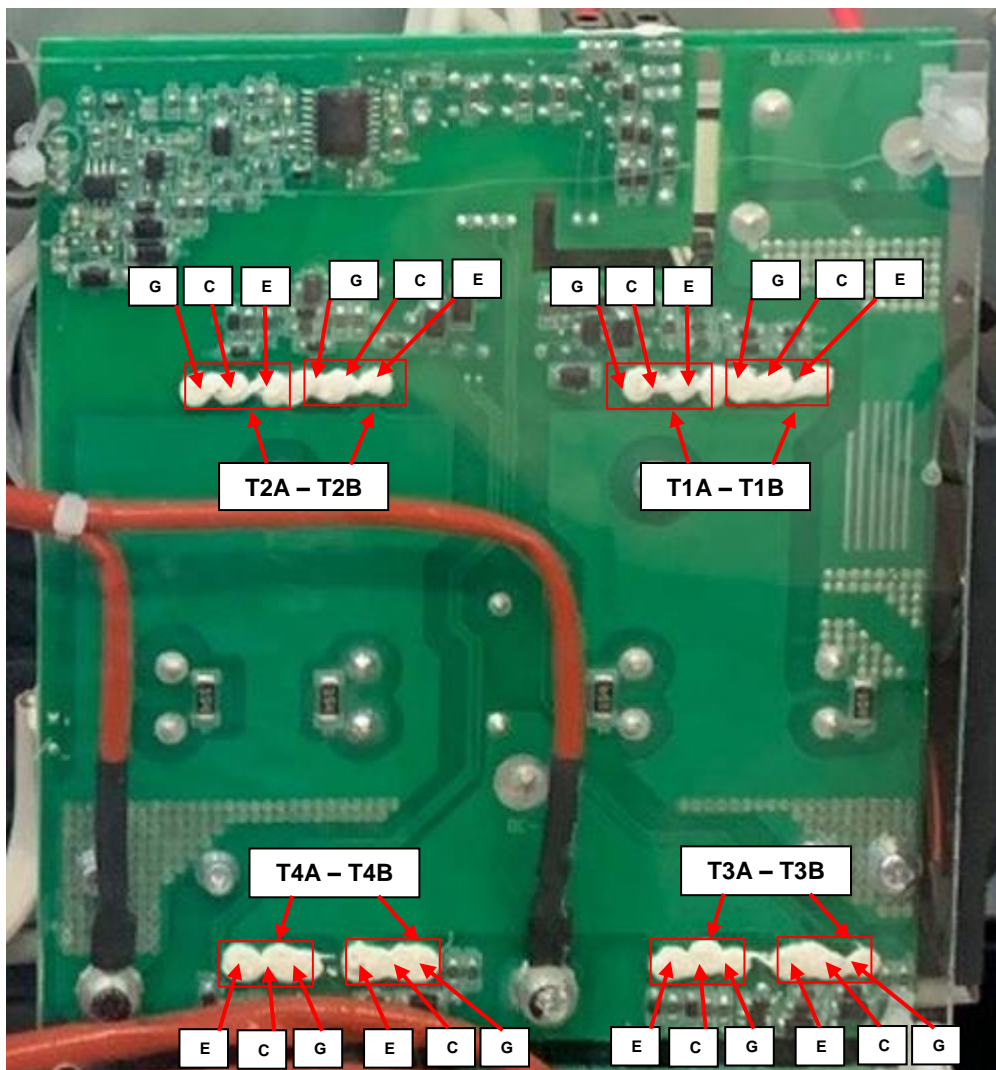

TEST PROCEDURE

1. Remove main input power to the QUICKMIG 250 & 300
2. Perform the **Discharge procedure**
3. Remove the plastic protection before proceeding with the following tests.
4. Without disconnect any cables check Inverter IGBT **T1A,T1B,T2A,T2B, T3A,T3B, T4A, T4B** using the Volt-Ohmmeter (diode test mode), following the **Table tests 1**

IGBT T1A,T1B,T2A,T2B, T3A,T3B, T4A, T4B - Table tests 1

<i>Positive Probe (RED)</i>	<i>Negative Probe (BLACK)</i>	<i>Value</i>
Emitter (E)	Collector (C)	0.3V - 0.7V
Collector (C)	Emitter (E)	OPEN
Emitter (G)	Gate (E)	0.7V - 0.8V

RECTIFICATION BOARD RESISTANCE TEST

WARNING

Service and repair should be performed by only Lincoln Electric factory trained personnel. Unauthorized repairs performed on this equipment may result in danger to the technician or machine operator and will invalidate your factory warranty. For your safety and to avoid electrical shock, please observe all safety notes and precautions detailed throughout this manual. If for any reason you do not understand the test procedures or are unable to perform the test/repairs safely, contact your Local Lincoln Electric Service Department for electrical troubleshooting assistance before you proceed.

.....

TEST DESCRIPTION

This test will determine if the Inverter board has failed.

MATERIALS NEEDED

Volt / Ohmmeter
Machine Wiring Diagram

RECTIFICATION BOARD RESISTANCE TEST (continued)

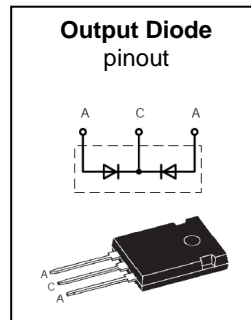
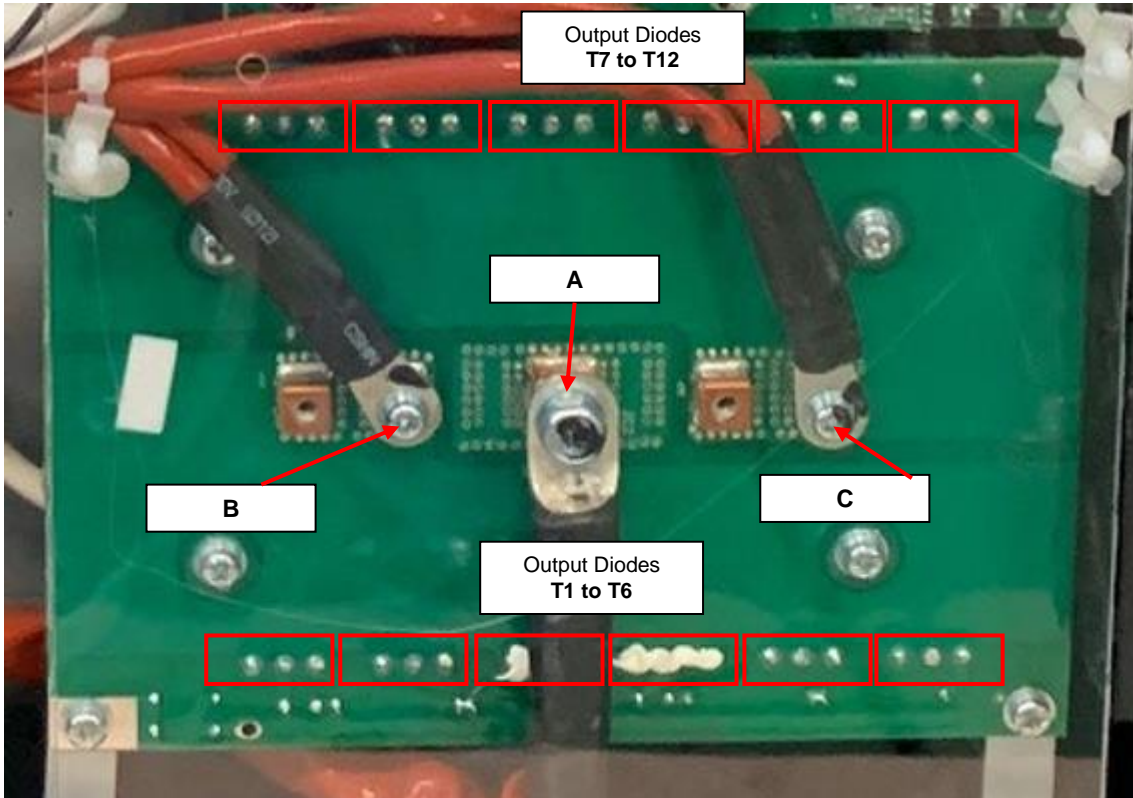

Figure is showing PCB version for QUICKMIG 300

TEST PROCEDURE

1. Remove main input power to the QUICKMIG 250 & 300
2. Perform the **Discharge procedure**
3. Remove the cables (A)
4. Using the multi-meter (diode test mode) check the output diode (T1 to T12 in case of QUICKMIG 300) for short circuits following the Test Table 2 below and the diode module pinout available on the top right side of this page:

Test table 2 - Diode T1 to T12

Positive Probe (RED)	Negative Probe (BLACK)	Value
A	B	Open
A	C	Open
B	A	0.29V
C	A	0.29V

5. If the above tests are not correct the rectification board may be faulty and has to be replaced

INVERTER BOARD VOLTAGE TEST

WARNING

Service and repair should be performed by only Lincoln Electric factory trained personnel. Unauthorized repairs performed on this equipment may result in danger to the technician or machine operator and will invalidate your factory warranty. For your safety and to avoid electrical shock, please observe all safety notes and precautions detailed throughout this manual. If for any reason you do not understand the test procedures or are unable to perform the test/repairs safely, contact your Local Lincoln Electric Service Department for electrical troubleshooting assistance before you proceed.

.....

TEST DESCRIPTION

This test will help to determine if the main inverter board is receiving the correct input voltages and if the correct regulated voltages are being processed and maintained by the inverter.

MATERIALS NEEDED

Volt / Ohmmeter
Machine Wiring Diagram

INVERTER BOARD VOLTAGE TEST (continued)

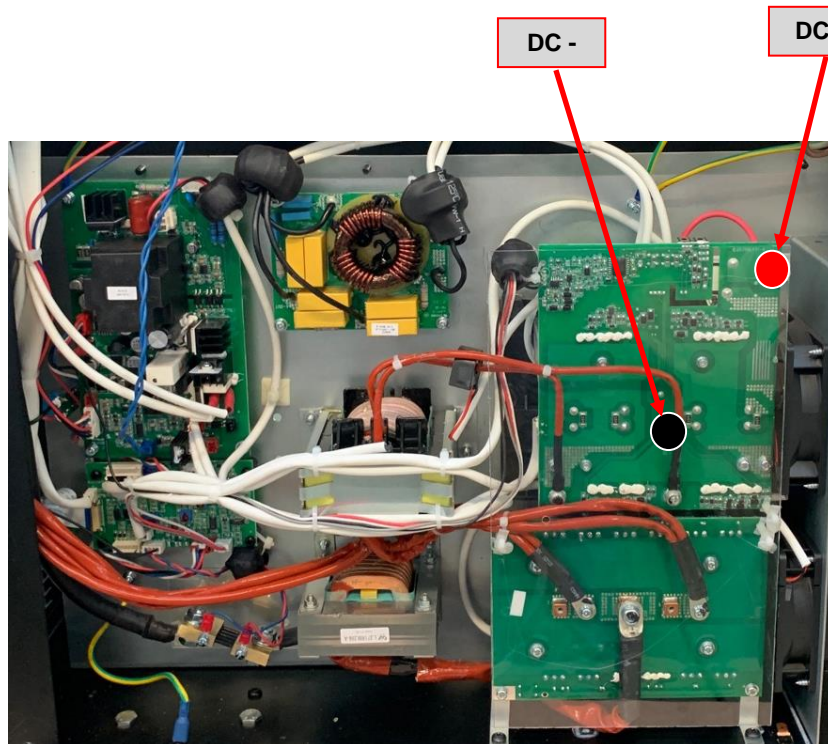

TEST PROCEDURE

- ⚠ Use always electrically insulate gloves during this test procedure**
1. Carefully apply 400Vac +/- 15% input voltage via the input cable to the QUICKMIG 250 or 300
 2. Switch to ON position the mains switch located on the back of the machine
 3. Check for 565Vdc +/-15% between terminals **DC +** and **DC -**
 4. If voltage is not present check the EMC filter and the main switch.

AUXILIARY POWER BOARD TEST

WARNING

Service and repair should be performed by only Lincoln Electric factory trained personnel. Unauthorized repairs performed on this equipment may result in danger to the technician or machine operator and will invalidate your factory warranty. For your safety and to avoid electrical shock, please observe all safety notes and precautions detailed throughout this manual. If for any reason you do not understand the test procedures or are unable to perform the test/repairs safely, contact your Local Lincoln Electric Service Department for electrical troubleshooting assistance before you proceed.

.....

TEST DESCRIPTION

This test will help to determine if the correct input voltages are applied to the voltage supply board and also if the correct regulated voltages are being processed by the board.

MATERIALS NEEDED

Volt/Ohmmeter
Machine Wiring Diagram

AUXILIARY POWER BOARD TEST (continued)

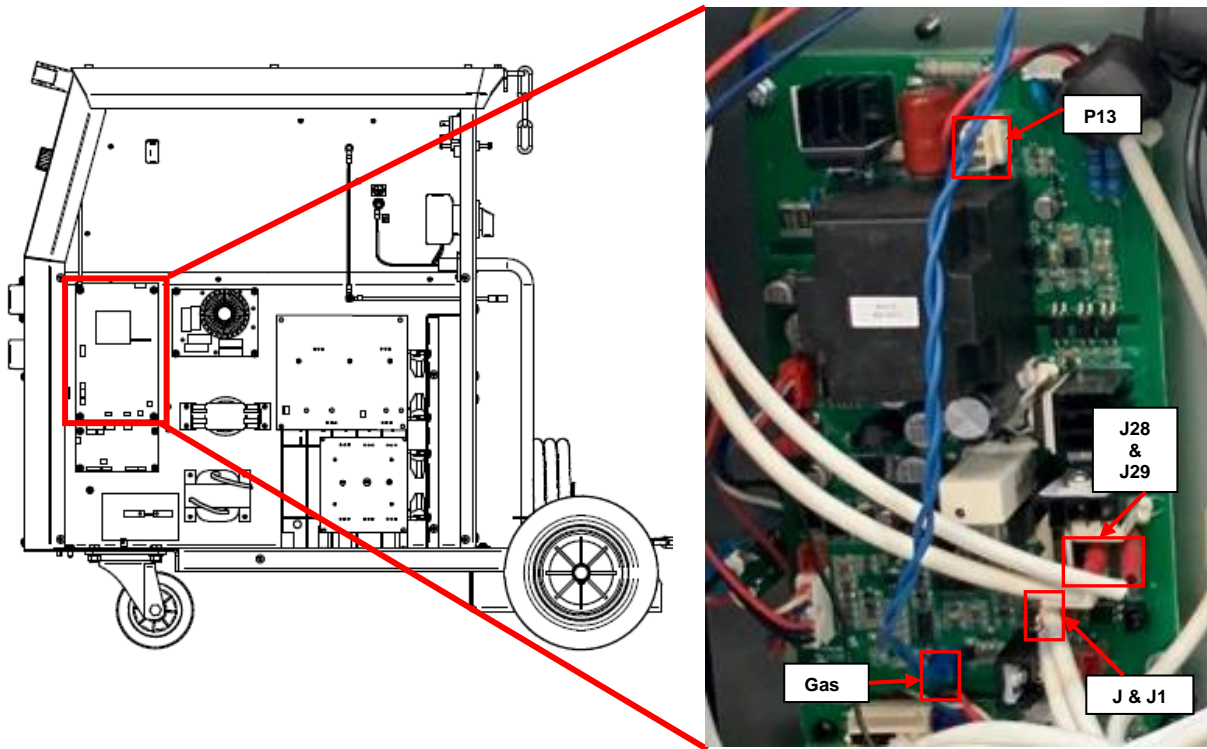

TEST PROCEDURE

⚠ **Use always electrically insulate gloves during this test procedure**

1. Carefully apply 400Vac +/- 15% input voltage via the input cable to the QUICKMIG 250 or 300
2. Switch to ON position the mains switch located on the back of the machine
3. Follow the below tables tests:

J and J1: Auxiliary supply board to Fans

Pin #	Description	Value	Notes
1	Power Supply for Fans	+ 24Vdc +/- 15%	Present only during welding or thermal error
2		SGND	

GAS: Auxiliary supply board to GAS solenoid

Pin #	Description	Value	Notes
1	Power Supply for Gas solenoid	+24 VDC +/- 15%	Present only when Trigger is pressed or during postflow
2		GND	

J28 – J29: Auxiliary supply board to Drive Motor

Pin #	Description	Value	Notes
J28	Power Supply for wire drive motor	From + 2,3 Vdc to 17,5Vdc depending by WFS setting	Present only when Trigger is pressed
J29			

P13: Main Board to Auxiliary supply board

Pin #	Description	Value	Notes
P13-1	Rectifier input Voltage	565 VDC	Present only when Trigger is pressed
P13-3			

CONTROL BOARD TEST

WARNING

Service and repair should be performed by only Lincoln Electric factory trained personnel. Unauthorized repairs performed on this equipment may result in danger to the technician or machine operator and will invalidate your factory warranty. For your safety and to avoid electrical shock, please observe all safety notes and precautions detailed throughout this manual. If for any reason you do not understand the test procedures or are unable to perform the test/repairs safely, contact your Local Lincoln Electric Service Department for electrical troubleshooting assistance before you proceed.

.....

TEST DESCRIPTION

This test will help to determine if the correct input voltages are applied to the voltage supply board and also if the correct regulated voltages are being processed by the board.

MATERIALS NEEDED

Volt/Ohmmeter
Machine Wiring Diagram

CONTROL BOARD TEST (continued)

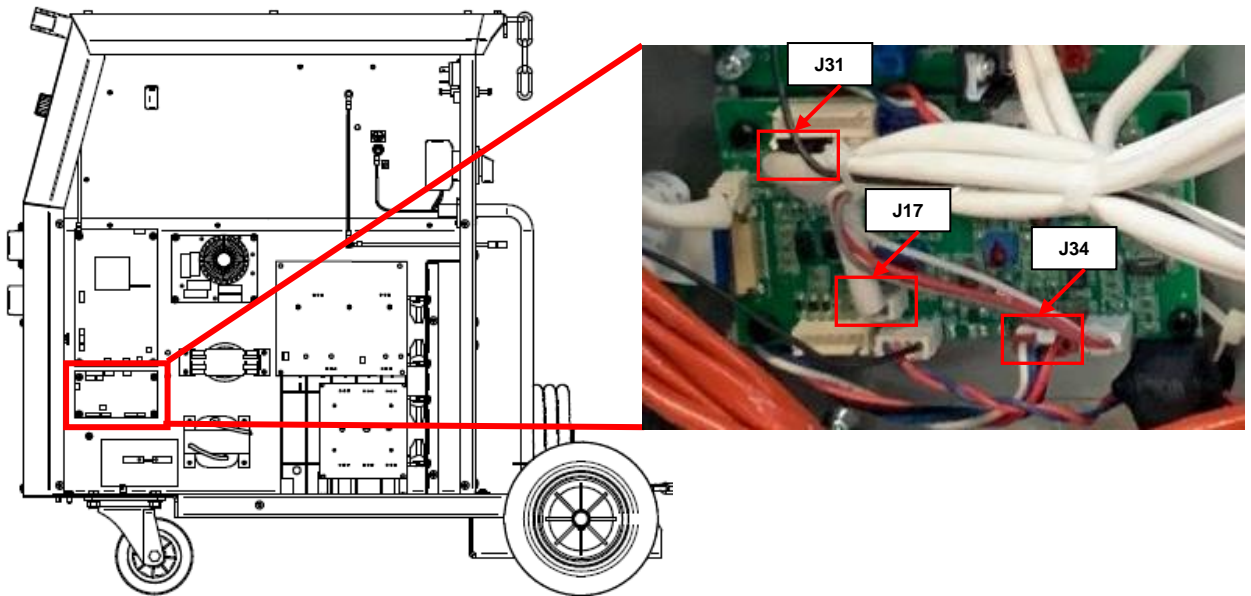

TEST PROCEDURE

⚠ Use always electrically insulate gloves during this test procedure

1. Carefully apply 400Vac +/- 15% input voltage via the input cable to the QUICKMIG 250 or 300
2. Switch to ON position the mains switch located on the back of the machine
3. Follow the below tables tests:

J34: Auxiliary supply board to Control Board

Pin #	Description	Value	Notes
3	Supply 5 Vdc	+ 5Vdc	Supply voltages for Control Board
5		GND	
2	VCC	+ 30Vdc	
4			

4. If fault of the machine is that always thermal error is present, proceed with following tests:
5. Switch OFF the machine and unplug it from the wall plug.
6. Disconnect the connector **J31** and measure between female connector **J31-1 / J31-2, J31-3 / J31-4 (Thermal sensor Y2 – Y3)**, you need to find an open circuit.
7. Disconnect the connector **J17** and measure between female connector **J17-1 / J17-2 (Thermal sensor Y1)**, value must be 0 (zero) Ohm.

DISASSEMBLY OPERATIONS

EMC, AUXILIARY SUPPLY AND CONTROL PCB REMOVAL AND REPLACEMENT PROCEDURE

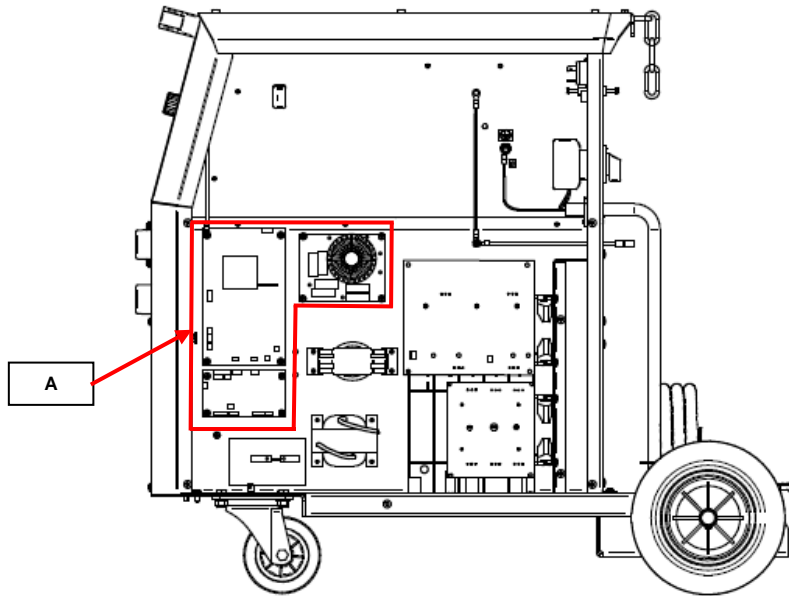

Figure 1

REMOVAL PROCEDURE

Necessary tools:

- PH02 screwdriver

1. Remove main input power to the QUICKMIG 250 or 300
2. Open the right side panel of the machine following the case cover removal procedure.
3. Perform the **Discharge procedure**
4. Locate the EMC, AUXILIARY SUPPLY AND CONTROL PCB, inside the area "A". See **Figure1**.
5. Remove all the cables and plugs from the board that you need to remove.
6. Remove the 4 screws that are at the corners of the board that you need to remove.
7. Carefully remove the board from the machine.

For the board re-assembly operations, make the previous steps in the reverse order.

DISASSEMBLY OPERATIONS

FAN REMOVAL AND REPLACEMENT PROCEDURE

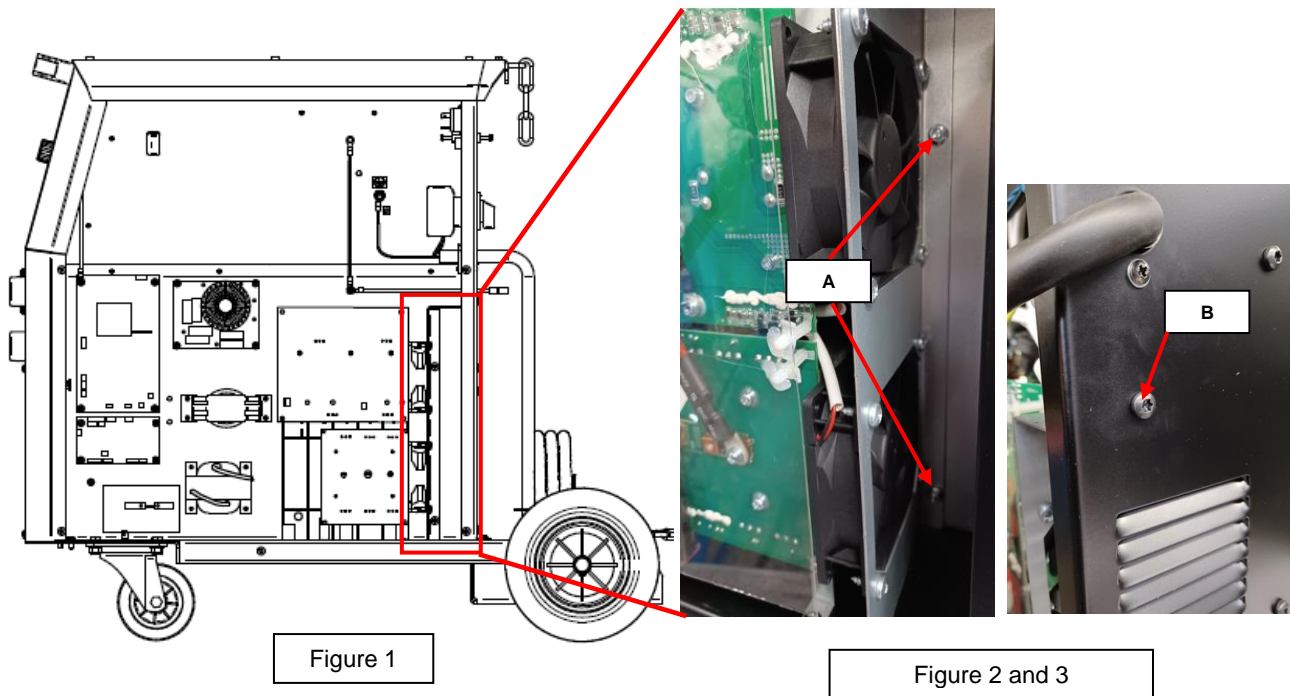

Figure 1

Figure 2 and 3

REMOVAL PROCEDURE

Necessary tools:

- PH02 screwdriver

1. Remove main input power to the QUICKMIG 250 or 300
2. Open the right side panel of the machine following the case cover removal procedure.
3. Perform the **Discharge procedure**
4. Locate the fans. See **Figure1**.
5. Remove all the cables from connector **J** and **J1** of the Auxiliary Power Board.
6. Remove the 2 screws (A) using scredriver PH02, and the screw (B) using the TX25 scredriver from the rear panel. See **Figure2 and 3**.
7. Carefully remove the fans support from the machine and remove the faulty fan using a PH02 screwdriver.
8. **For the fans re-assembly operations**, make the previous steps in the reverse order.

DISASSEMBLY OPERATIONS

INVERTER AND OUTPUT BOARD REMOVAL AND REPLACEMENT PROCEDURE

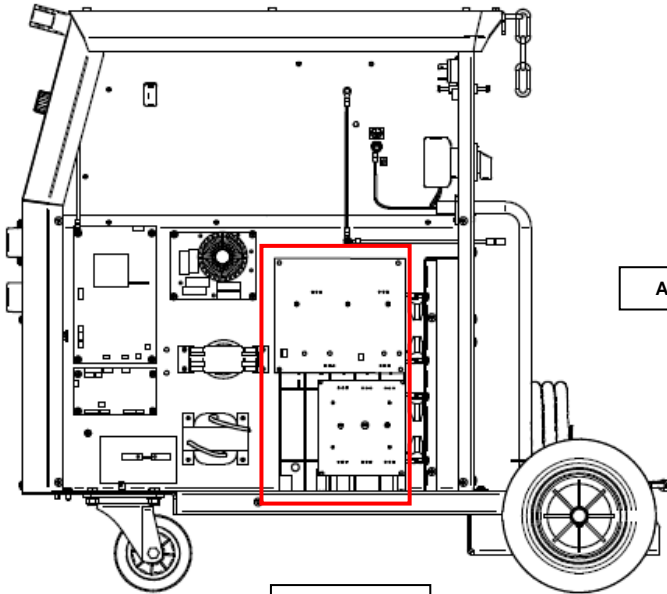

Figure 1

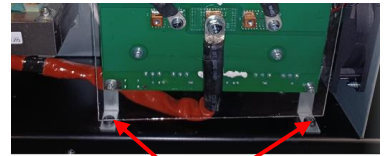
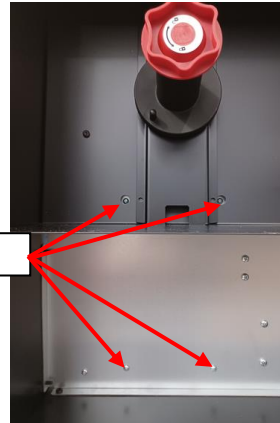

Figure 2 and 3

REMOVAL PROCEDURE

Necessary tools:

- PH02 screwdriver
- TX25 torx screwdriver

1. Remove main input power to the QUICKMIG 250 or 300
2. Open the right and left side panels of the machine following the case cover removal procedure.
3. Perform the **Discharge procedure**
4. Locate the inverter and output board. See **Figure1**.
5. Remove all the cables from both Boards.
6. Remove the 4 screws (**A**) located on the left side of the machine
7. Remove the 2 screws (**B**) using TX25 screwdriver. See **Figure2 and 3**.
8. Carefully remove the block that includes the inverter and the output boards
9. Remove the screws that hold the inverter board or the output board (depending of which it is faulty) on the black plastic and remove the inverter board.
10. **For the Inverter or output board re-assembly operations**, make the previous steps in the reverse order.

DISASSEMBLY OPERATIONS

WIRE DRIVE REMOVAL AND REPLACEMENT PROCEDURE

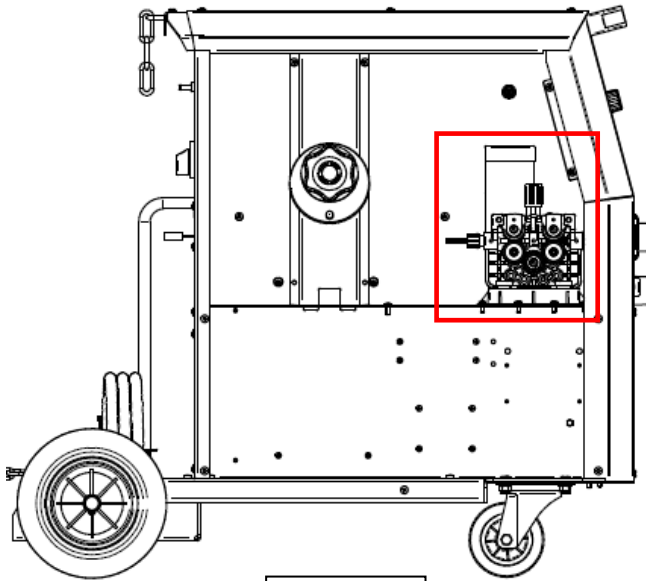

Figure 1

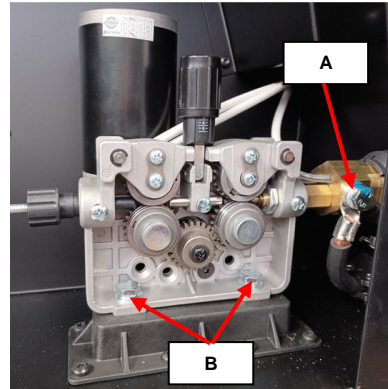

Figure 2

REMOVAL PROCEDURE

Necessary tools:

- PH02 screwdriver
- 13mm wrench

1. Remove main input power to the QUICKMIG 250 or 300
2. Open the right side panel of the machine following the case cover removal procedure.
3. Perform the **Discharge procedure**
4. Locate the wire drive assembly. See **Figure1**.
5. Remove the cables from connector J28 and J29 on Auxiliary Power Board and J4 from Control Board.
6. Using a 13 mm wrench remove the power cable (**A**). See **Figure2**.
7. Using a 13mm wrench remove the 2 screws (**B**). See **Figure2**.
8. Carefully remove the wire drive block.
9. **For the wire drive block re-assembly operations**, make the previous steps in the reverse order.

DISASSEMBLY OPERATIONS

GAS SOLENOID REPLACEMENT PROCEDURE

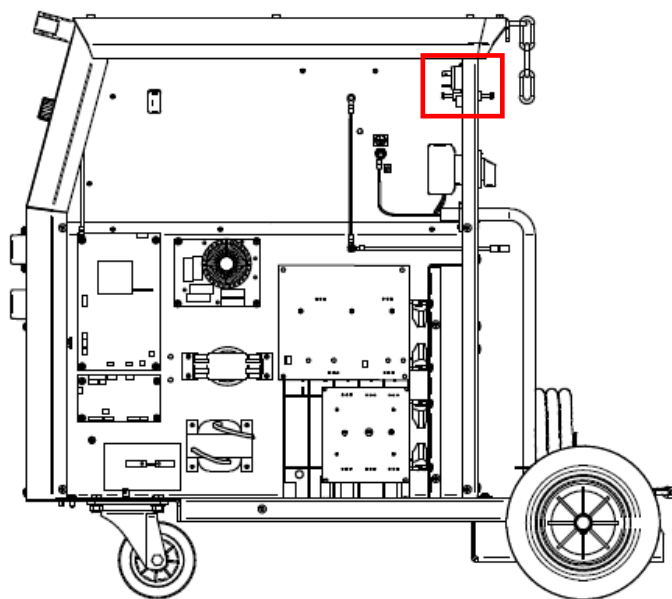

Figure 1

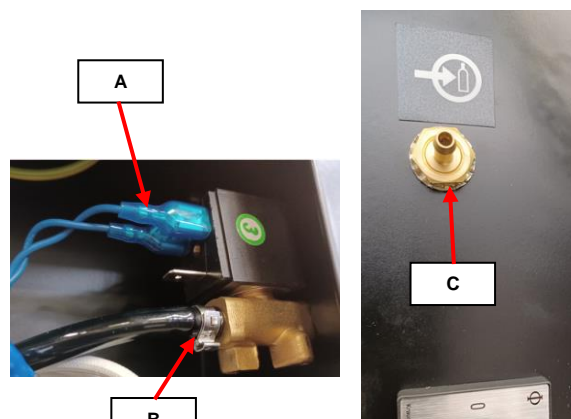

Figure 2

REMOVAL PROCEDURE

Necessary tools:

- Nippers
- 17mm wrench

1. Remove main input power to the QUICKMIG 250 or 300
2. Open the right side panel of the machine following the case cover removal procedure.
3. Perform the **Discharge procedure**
4. Locate the gas solenoid. See **Figure1**.
5. Remove the 2 cables (**A**) from the gas solenoid. See **Figure2**.
6. Using a nippers remove the metal clamp (**B**). See **Figure2**.
7. Using a 17mm wrench remove the nut (**C**). See **Figure2**.
8. Carefully remove the gas solenoid.
9. **For the gas solenoid re-assembly operations**, make the previous steps in the reverse order.

DISASSEMBLY OPERATIONS

FRONT PANEL BOARD REMOVAL AND REPLACEMENT PROCEDURE

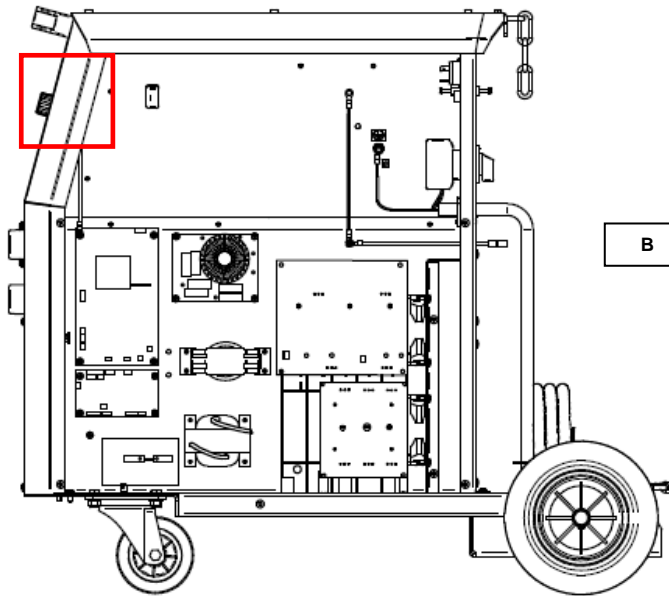

Figure 1

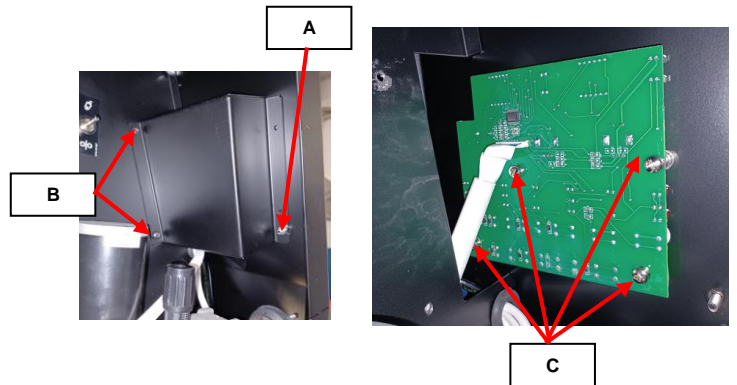

Figure 2

REMOVAL PROCEDURE

Necessary tools:

- PH02 screwdriver
- 8mm socket wrench
- TX25 wrench

1. Remove main input power to the QUICKMIG 250 or 300
2. Open the right side panel of the machine following the case cover removal procedure.
3. Perform the **Discharge procedure**
4. Locate the front panel board. See **Figure1**.
5. Remove the flat cable from J22 connector located on the Control board.
6. Using the 8mm socket wrench remove the nut (**A**). See **Figure2**.
7. Using TX25 wrench remove the 2 screws (**B**). See **Figure2**.
8. Remove the black cover from the machine.
9. Using the PH02 screwdriver remove the 4 screws (**C**). See **Figure2**.
10. Carefully remove the front panel board.
11. **For the front panel board re-assembly operations**, make the previous steps in the reverse order.

RETEST AFTER REPAIR

Should a machine under test be rejected for any reason requiring the removal of any mechanical part that could affect the machine's electrical characteristics, or if any electrical components are repaired or replaced, the machine must be retested.

Machine input and output

QUICKMIG 250 & 300

Model	Input Voltage	Max. Input Current (A)	Rated Output in GMAW
QUICKMIG 250	400Vac/3ph/50Hz	22,5 max	250A@35%
QUICKMIG 300	400Vac/3ph/50Hz	19,8 max	300A@35%

Output current range GMAW - FCAW
50-250 Amps – QUICKMIG 250
50-300 Amps – QUICKMIG 300

Output current range SMAW
10-250 Amps – QUICKMIG 250 & 300

Maximum Open Circuit Voltage $U_{0 \text{ peak}}$
72 Vp

! IMPORTANT !

After the repair, the unit shall be tested accordingly to the norm **EN60974-4**
Arc welding equipment “In-service inspection and testing”

CALIBRATION PROCEDURE

Calibrate the Max current preset:

1. Input 3~380V supply voltage, turn on the machine and select MMA mode.
2. Preset the current to maximum, connect output to load bank;
3. Adjust the load bank and the VR1, to make the output to 250~253A/29~30V;

Calibrate the current display accuracy:

1. Adjust the VR2, make the display current same as the measure output current;

Calibrate WFS

1. Select to manual MIG mode, connect to load bank, and then short the torch switch on Euro connector, make the output current at about 50~100A;
2. Preset the WFS to minimum(1.5m/min), adjust the VR4 make the feeder speed to 21 ± 1 RPM;
3. Preset the WFS to maximum(18m/min), adjust the VR3 make the feeder speed to 197 ± 2 RPM;

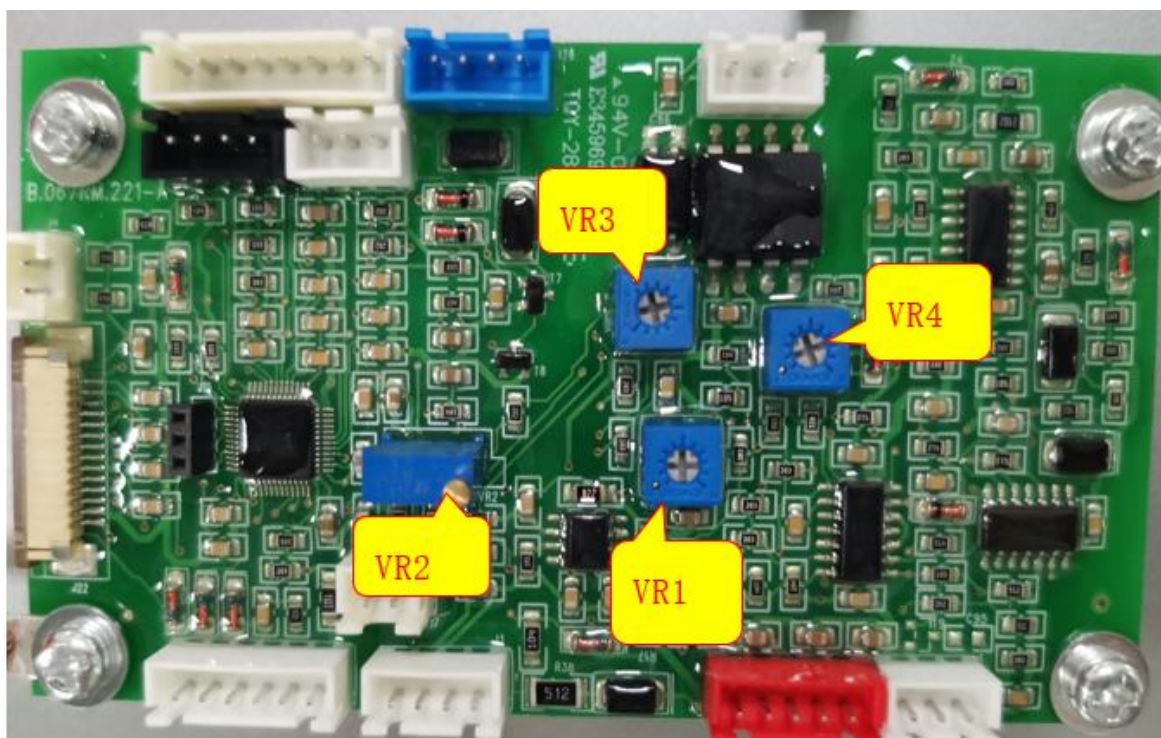

ELECTRICAL SCHEMATICS

Block Diagram

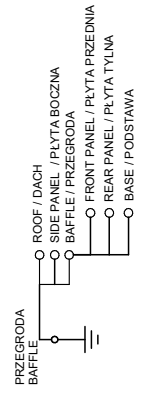
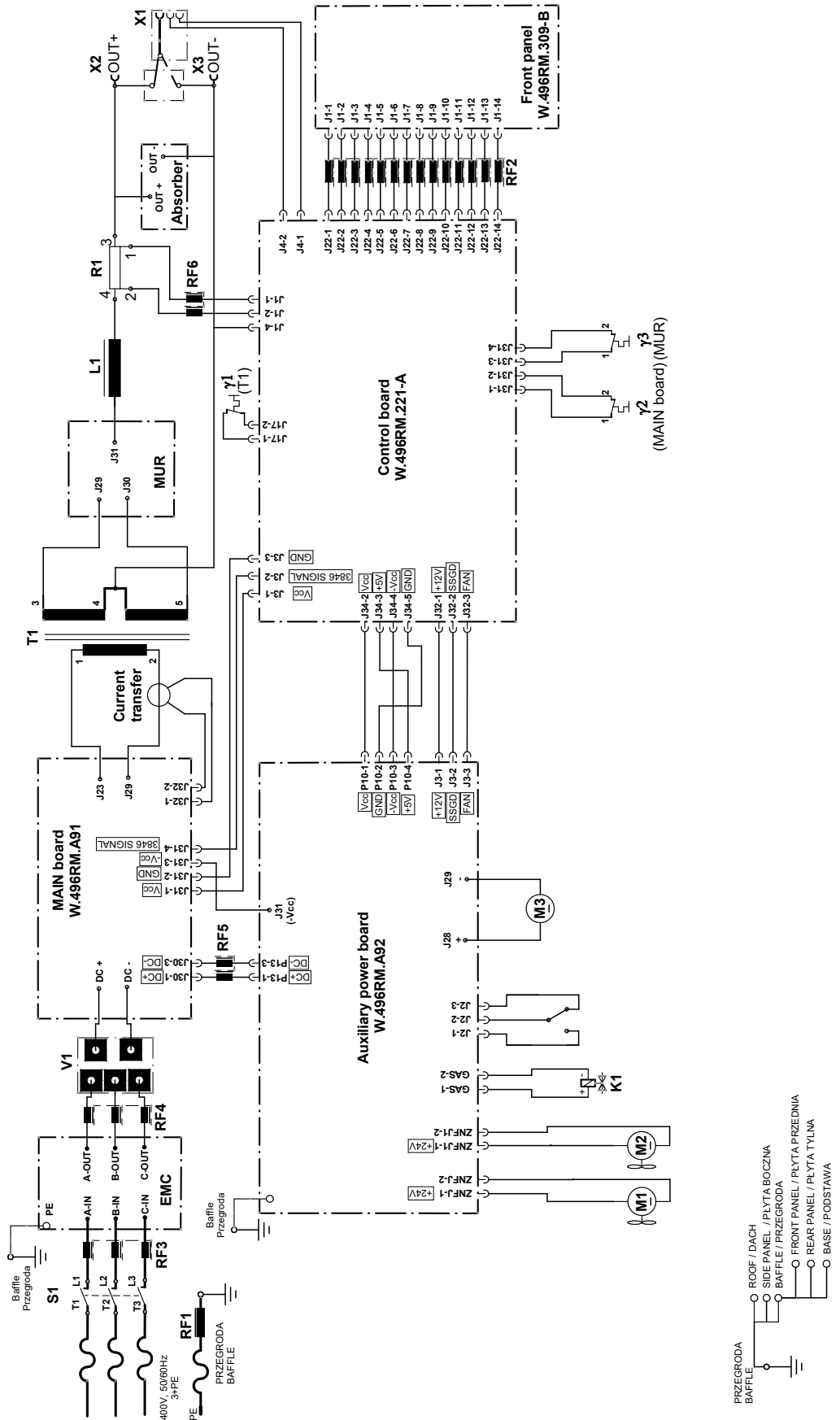

NOTE
