

(A) INPUT AND MOTOR POWER CIRCUIT

(B) CONTROL POWER SUPPLY AND RELAY CIRCUIT

(C) MOTOR CONTROL CIRCUIT

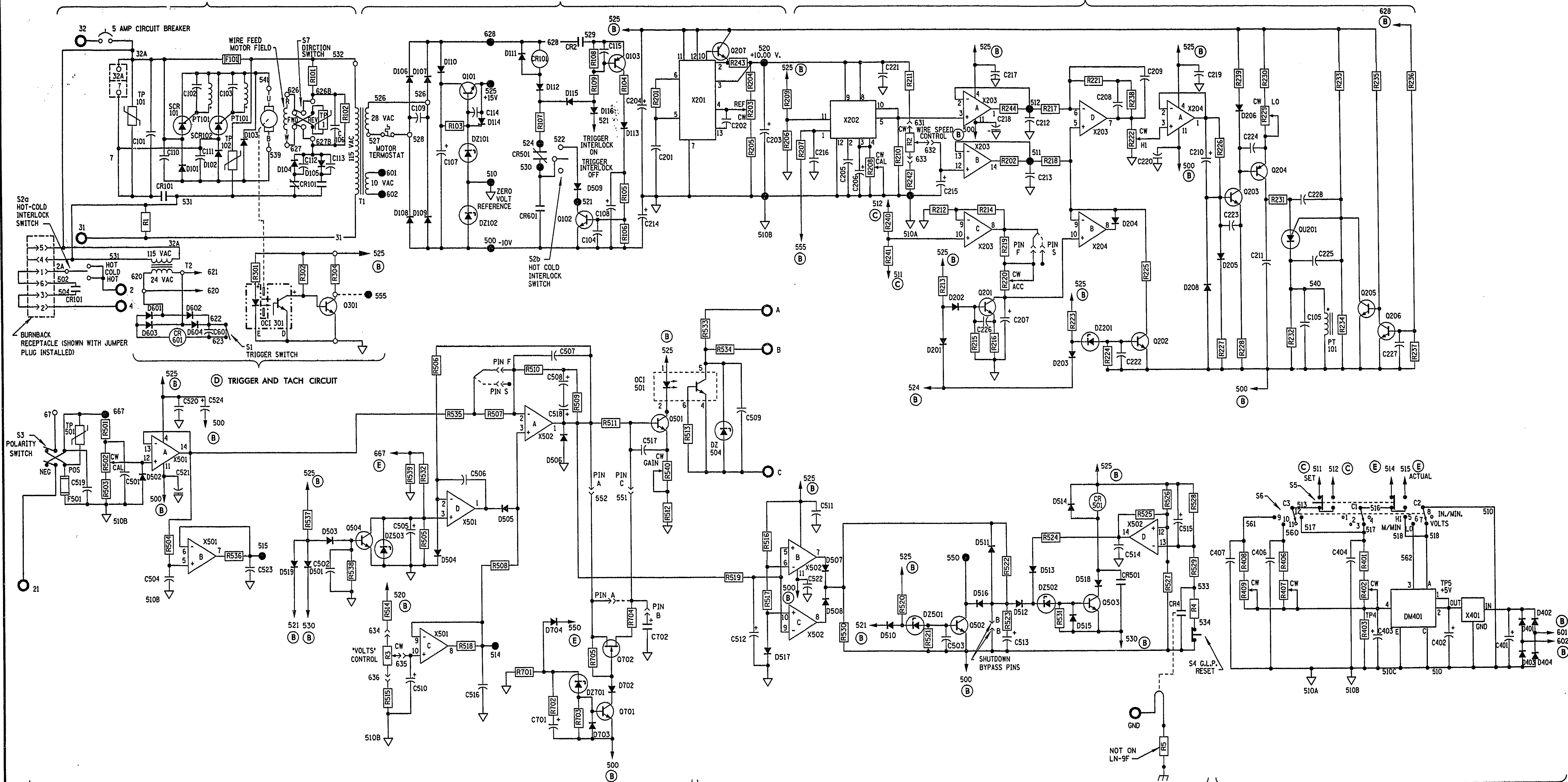

(D) TRIGGER AND TACH CIRCUIT

(E) VOLTAGE CONTROL CIRCUIT

(F) SHUTDOWN CIRCUIT

(G) METER CIRCUIT

C101	.005 MFD	
C102	.047 MFD	
C103	.022 MFD	
C104	.047 MFD	
C105	.01 MFD	
C106	50 MFD	R101 40 OHM 12W
C107	150 MFD	R102 100K OHM
C108	2.7 MFD	R103 330 OHM
C109	.15 MFD	R104 1K OHM
C110	.005 MFD	R105 10K OHM
C111	.005 MFD	R106 100K OHM
C112	.02 MFD	R107 10 OHM
C113	.02 MFD	R108 2.2K OHM
C114	.022 MFD	R109 15K OHM
C115	.022 MFD	
D101	16A	CR101 3PDT 24 VDC
D102	16A	SCR101 12A, 400V
D103	16A	SCR102 12A, 400V
D104	1A 1000V	
D105	1A 1000V	
D106	1A	Q101 2N5655
THRU D116		Q102 2N5655
		Q103 MPS A92
DZ101	15V, 5W	PT101 1:1 PULSE TRANSFORMER
DZ102	10V, 5W	TP101 TRANSIENT PROTECTOR
		TP102 TRANSIENT PROTECTOR

*C105 AND PT101 PRIMARY ARE SHOWN IN SECTION C

C201	.022 MFD	R208 100K OHM TRIMMER
C202	.022 MFD	R209 33K OHM
C203	18 MFD	R210 10K OHM
C204	4.7 MFD	R211 5.6K OHM
C205	.0033 MFD	R212 15K OHM
C206	.47 MFD	R213 47K OHM
C207	18 MFD	R214 15K OHM
C208	4 MFD	R215 100K OHM
C209	.047 MFD	R216 1K OHM
C210	.047 MFD	R217 1K OHM
C211	.15 MFD	R218 1K OHM
C212	.022 MFD	R219 33K OHM
C213	.022 MFD	R220 50K OHM TRIMMER
C214	4.7 MFD	R221 15K OHM
C215	18 MFD	R222 10K OHM TRIMMER
C216	100pF	R223 33K OHM
C217	100pF	R224 100K OHM
C218	.022 MFD	R225 1K OHM
C219	.022 MFD	R226 1K OHM
C220	.022 MFD	R227 6.8K OHM
C221	100pF	R228 10K OHM
C222	.022 MFD	R229 20K OHM TRIMMER
C223	.022 MFD	R230 27K OHM
C224	.022 MFD	R231 15 OHM
C225	.022 MFD	R232 10K OHM
C226	.022 MFD	R233 6.8K OHM
C227	.022 MFD	R234 500 OHM TRIMMER
C228	.022 MFD	R235 10K OHM
C229	.022 MFD	R236 15K OHM
C230	.022 MFD	R237 10K OHM
C231	.022 MFD	R238 1M OHM
D201	1A	
D202	1A	
D203	1A	
D204	1A	
D205	1A	
D206	1A	
D207	1A	
D208	1A	
D209	1A	
D210	1A	
D211	1A	
D212	1A	
D213	1A	
D214	1A	
D215	1A	
D216	1A	
D217	1A	
D218	1A	
D219	1A	
D220	1A	
D221	1A	
D222	1A	
D223	1A	
D224	1A	
D225	1A	
D226	1A	
D227	1A	
D228	1A	
D229	1A	
D230	1A	
D231	1A	
D232	1A	
D233	1A	
D234	1A	
D235	1A	
D236	1A	
D237	1A	
D238	1A	

C401	500 MFD	R401 24.3K OHM 1/4W 1%
C402	4.7 MFD	R402 2K OHM TRIMMER
C403	27 MFD	R403 2.80K OHM 1/4W 1%
C404	4.0 MFD	R404 7.68K OHM 1/4W 1%
C405	.47 MFD	R405 102K OHM 1/4W 1%
C406	.022 MFD	R406 10K OHM TRIMMER
C407	.022 MFD	R407 102K OHM 1/4W 1%
C408	.022 MFD	R408 10K OHM TRIMMER
C409	.022 MFD	R409 10K OHM TRIMMER
D401	THRU D404	
D402	1A	
D403	1A	
D404	1A	
D405	1A	
D406	1A	
D407	1A	
D408	1A	
D409	1A	
D410	1A	
D411	1A	
D412	1A	
D413	1A	
D414	1A	
D415	1A	
D416	1A	
D417	1A	
D418	1A	
D419	1A	
D420	1A	
D421	1A	
D422	1A	
D423	1A	
D424	1A	
D425	1A	
D426	1A	
D427	1A	
D428	1A	
D429	1A	
D430	1A	
D431	1A	
D432	1A	
D433	1A	
D434	1A	
D435	1A	
D436	1A	
D437	1A	
D438	1A	
D439	1A	
D440	1A	

FOR VOLTMETER P.C. BOARDS
L6687-1 OR HIGHER USE S2145
SCHEMATIC FOR COMPONENT
VALUES AND CIRCUIT CONNECTIONS.

C501	.1 MFD	F501 1/8 AMP FAST BLOW FUSE
C502	.022 MFD	OC1501 OPTO-ISOLATOR
C503	.022 MFD	O501 2N4123
C504	4.0 MFD	O502 2N4123
C505	.47 MFD	O503 2N816
C506	.022 MFD	O504 2N4123
C507	.022 MFD	O505 2N4123
C508	.39 MFD	X501 I.C. QUAD OP-AMP
C509	.022 MFD	X502 I.C. QUAD OP-AMP
C510	1.8 MFD	TP501 TRANSIENT PROTECTOR
C511	.022 MFD	R501 44.2K OHM 1/4W 1%
C512	4.7 MFD	R502 500 OHM TRIMMER
C513	50 MFD	R503 4.75K OHM 1/4W 1%
C514	.022 MFD	R504 100K OHM
C515	1 MFD	R505 22K OHM
C516	.022 MFD	R506 10K OHM
C517	.022 MFD	R507 33K OHM
C518	.39 MFD	R508 10K OHM
C519	.005 MFD	R509 4.7MEG OHM
C520	.022 MFD	R510 10K OHM
C521	.022 MFD	R511 470 OHM
C522	.022 MFD	R512 2.7MEG OHM
C523	.022 MFD	R513 1.8K OHM
C524	4.7 MFD	R514 5.6K OHM
C525	.022 MFD	R515 1.8K OHM
C526	.022 MFD	R516 6.8K OHM
C527	.022 MFD	R517 27K OHM
C528	.022 MFD	R518 270 OHM
C529	.022 MFD	R519 10K OHM
C530	.022 MFD	R520 33K OHM
C531	.022 MFD	R521 100K OHM
C532	.022 MFD	R522 15K OHM
C533	.022 MFD	R523 1K OHM
C534	.022 MFD	R524 4.7K OHM
C535	.022 MFD	R525 4.7K OHM
C536	.022 MFD	R526 22K OHM
C537	.022 MFD	R527 22K OHM
C538	.022 MFD	R528 22K OHM
C539	.022 MFD	R529 2.2K OHM
C540	.022 MFD	R530 15K OHM
C541	.022 MFD	R531 100K OHM
C542	.022 MFD	R532 27K OHM
C543	.022 MFD	R533 10K OHM
C544	.022 MFD	R534 100 OHM
C545	.022 MFD	R535 1K OHM
C546	.022 MFD	R536 270 OHM
C547	.022 MFD	R537 33K OHM
C548	.022 MFD	R538 10K OHM
C549	.022 MFD	R539 100K OHM
C550	.022 MFD	R540 2K OHM TRIMMER

■D509 AND CR501 N.C. CONTACT ARE SHOWN IN SECTION B

C601	.15 MFD	R601 100K OHM
C602	.022 MFD	R602 15K OHM
C603	.022 MFD	R603 1K OHM
C604	4.0 MFD	R604 4.7K OHM
C605	.47 MFD	R605 22K OHM
C606	.022 MFD	R606 10K OHM
C607	.022 MFD	R607 10K OHM
C608	.022 MFD	R608 10K OHM
C609	.022 MFD	R609 10K OHM
C610	.022 MFD	R610 10K OHM
C611	.022 MFD	R611 10K OHM
C612	.022 MFD	R612 10K OHM
C613	.022 MFD	R613 10K OHM
C614	.022 MFD	R614 10K OHM
C615	.022 MFD	R615 10K OHM
C616	.022 MFD	R616 10K OHM
C617	.022 MFD	R617 10K OHM
C618	.022 MFD	R618 10K OHM
C619	.022 MFD	R619 10K OHM
C620	.022 MFD	R620 10K OHM
C621	.022 MFD	R621 10K OHM
C622	.022 MFD	R622 10K OHM
C623	.022 MFD	R623 10K OHM
C624	.022 MFD	R624 10K OHM
C625	.022 MFD	R625 10K OHM
C626	.022 MFD	R626 10K OHM
C627	.022 MFD	R627 10K OHM
C628	.022 MFD	R628 10K OHM
C629	.022 MFD	R629 10K OHM
C630	.022 MFD	R630 10K OHM
C631	.022 MFD	R631 10K OHM
C632	.022 MFD	R632 10K OHM
C633	.022 MFD	R633 10K OHM
C634	.022 MFD	R634 10K OHM
C635	.022 MFD	R635 10K OHM
C636	.022 MFD	R636 10K OHM
C637	.022 MFD	R637 10K OHM
C638	.022 MFD	R638 10K OHM
C639	.022 MFD	R639 10K OHM
C640	.022 MFD	R640 10K OHM

R1	2 OHM 50W
R2	10K OHM 2W POT.
R3	10K OHM 2W POT.
R4	22K OHM
R5	0.1 OHM
CR2	WELD CURRENT-REED SWITCH
CR4	S1 SPST TRIGGER SWITCH
S1	DPDT INTERLOCK SWITCH
S2	DPDT OFF INTERLOCK SWITCH
S3	DPDT POLARITY SWITCH
S4	SPST G.L.P. RESET SWITCH
S5	DPDT SET-ACTUAL SWITCH
S6	3 POLE VOLTS-SPEED SELECTOR SWITCH
S7	DPDT DIRECTION SWITCH
TP1	ISOVAC TRANSIENT PROTECTOR
T1	POWER SUPPLY TRANSFORMER
T2	TRIGGER SUPPLY TRANSFORMER

KEY TO SYMBOLS

- INPUT CABLE CONNECTION
- POWER OR SIGNAL SOURCE POINT
- REMOVABLE CONNECTION
- ∇ COMMON CONNECTION
- (A) THRU (G) SOURCE POINT CIRCUIT LOCATION

ELECTRICAL SYMBOLS PER E1537

LEAD COLOR CODING

- B - BLACK
- R - RED
- U - BLUE
- W - WHITE

SINCE COMPONENTS OR CIRCUITRY ON A PRINTED CIRCUIT BOARD MAY CHANGE WITHOUT AFFECTING THE INTERCHANGEABILITY OF A COMPLETE BOARD, THIS DIAGRAM MAY NOT SHOW THE EXACT COMPONENTS OR CIRCUITRY OF CONTROLS HAVING A COMMON CODE NUMBER.

THIS SHEET CONTAINS PROPRIETARY INFORMATION OWNED BY THE LINCOLN ELECTRIC CO. AND IS NOT TO BE REPRODUCED, DISCLOSED OR USED WITHOUT THE EXPRESS PERMISSION OF THE LINCOLN ELECTRIC CO.

UNLESS OTHERWISE SPECIFIED TOLERANCE ON HOLES PER E2006 ON 3 PLACE DECIMALS IS .005 ON 2 PLACE DECIMALS IS .002 ON ALL OTHERS IS .005 MATERIAL TOLERANCE PER TO AGENT WITH PUBLISHED STANDARDS.

THE LINCOLN ELECTRIC CO. CLEVELAND, OHIO U.S.A.

LN-9 AND LN-9F (METRIC)

OPERATING SCHEMATIC

SCALE NONE

DATE 5-22-71

NO. 1590