

# RANGER 305D MACHINE SCHEMATIC L12212-2 REV: B

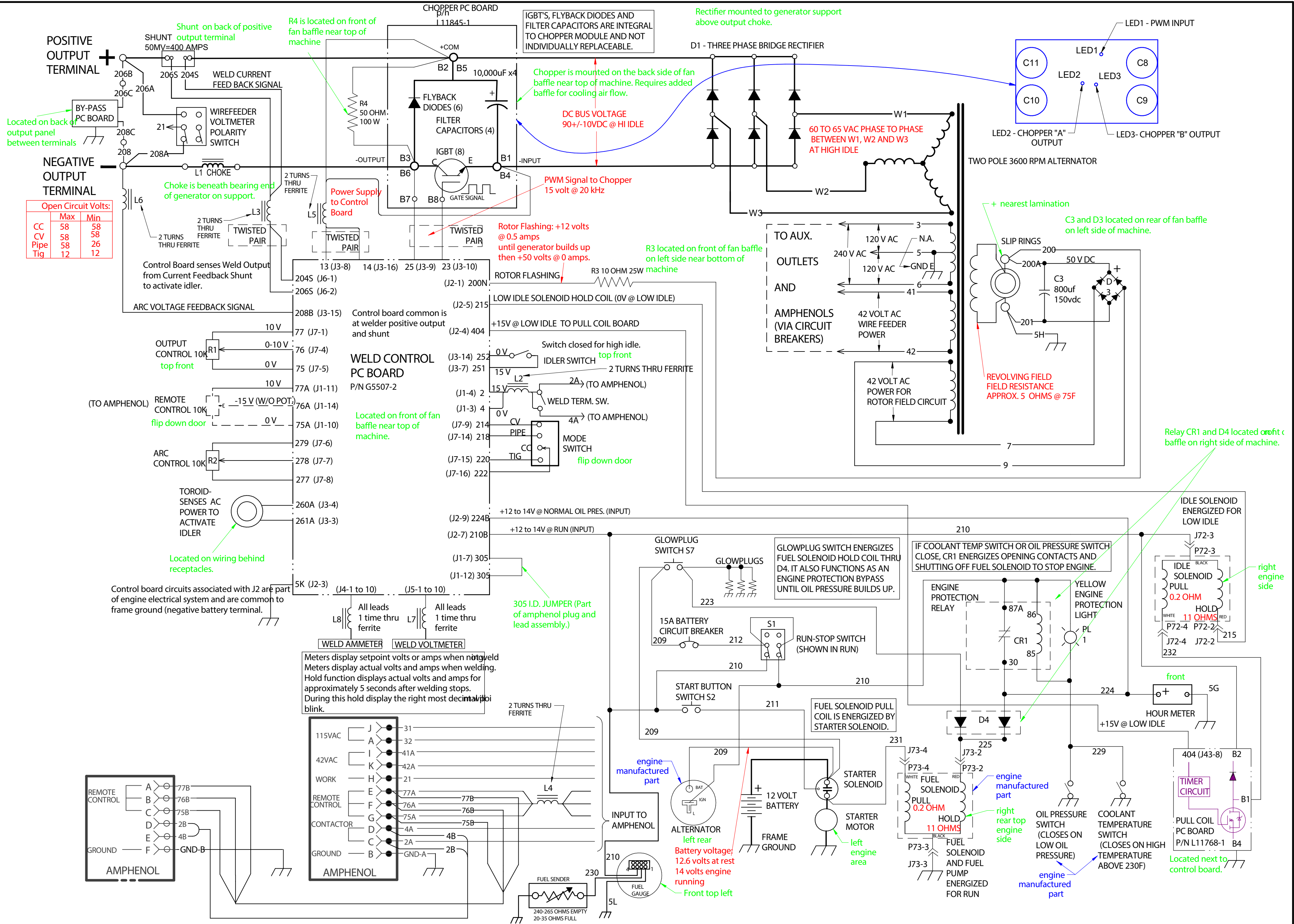

# RANGER 305D MACHINE SCHEMATIC L12212-2 REV: B PAGE 2

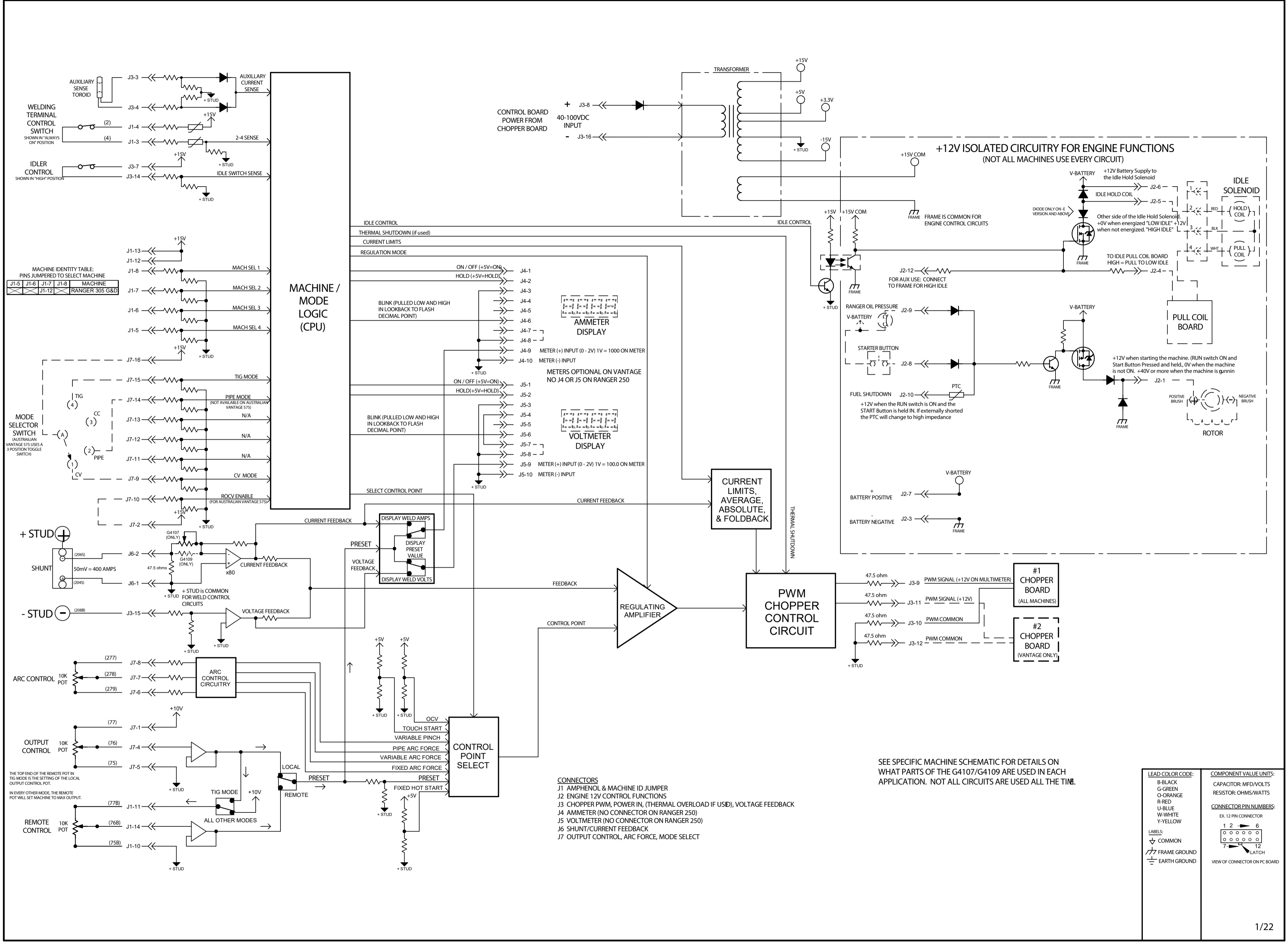

**MACHINE IDENTITY TABLE:**  
PINS JUMPERED TO SELECT MACHINE

| J1-5 | J1-6 | J1-7 | J1-8 | MACHINE        |
|------|------|------|------|----------------|
| X    | X    | X    | X    | RANGER 305 G&D |

- CONNECTORS**
- J1 AMPHENOL & MACHINE ID JUMPER
  - J2 ENGINE 12V CONTROL FUNCTIONS
  - J3 CHOPPER PWM, POWER IN, (THERMAL OVERLOAD IF USED), VOLTAGE FEEDBACK
  - J4 AMMETER (NO CONNECTOR ON RANGER 250)
  - J5 VOLT METER (NO CONNECTOR ON RANGER 250)
  - J6 SHUNT/CURRENT FEEDBACK
  - J7 OUTPUT CONTROL, ARC FORCE, MODE SELECT

SEE SPECIFIC MACHINE SCHEMATIC FOR DETAILS ON WHAT PARTS OF THE G4107/G4109 ARE USED IN EACH APPLICATION. NOT ALL CIRCUITS ARE USED ALL THE TIME.

| LEAD COLOR CODE:              | COMPONENT VALUE UNITS: |
|-------------------------------|------------------------|
| B-BLACK                       | CAPACITOR: MFD/VOLTS   |
| G-GREEN                       | RESISTOR: OHMS/WATTS   |
| O-ORANGE                      |                        |
| R-RED                         |                        |
| U-BLUE                        |                        |
| W-WHITE                       |                        |
| Y-YELLOW                      |                        |
| <b>CONNECTOR PIN NUMBERS:</b> |                        |
| EX 12 PIN CONNECTOR           |                        |
| VIEW OF CONNECTOR ON PC BOARD |                        |