



**NOTE:** This manual will cover most of the troubleshooting and repair procedures for the code numbers listed. Some variances may exist when troubleshooting/repairing later code numbers.

## ***POWER MIG<sup>®</sup> 200***

For use with machines having Code Numbers:

**10564, 10584**

# ***SERVICE MANUAL***

## ! WARNING

### ! CALIFORNIA PROPOSITION 65 WARNINGS !

Diesel engine exhaust and some of its constituents are known to the State of California to cause cancer, birth defects, and other reproductive harm.

The Above For Diesel Engines

The engine exhaust from this product contains chemicals known to the State of California to cause cancer, birth defects, or other reproductive harm.

The Above For Gasoline Engines

**ARC WELDING CAN BE HAZARDOUS. PROTECT YOURSELF AND OTHERS FROM POSSIBLE SERIOUS INJURY OR DEATH. KEEP CHILDREN AWAY. PACEMAKER WEARERS SHOULD CONSULT WITH THEIR DOCTOR BEFORE OPERATING.**

Read and understand the following safety highlights. For additional safety information, it is strongly recommended that you purchase a copy of "Safety in Welding & Cutting - ANSI Standard Z49.1" from the American Welding Society, P.O. Box 351040, Miami, Florida 33135 or CSA Standard W117.2-1974. A Free copy of "Arc Welding Safety" booklet E205 is available from the Lincoln Electric Company, 22801 St. Clair Avenue, Cleveland, Ohio 44117-1199.

**BE SURE THAT ALL INSTALLATION, OPERATION, MAINTENANCE AND REPAIR PROCEDURES ARE PERFORMED ONLY BY QUALIFIED INDIVIDUALS.**



### FOR ENGINE powered equipment.

1.a. Turn the engine off before troubleshooting and maintenance work unless the maintenance work requires it to be running.



1.b. Operate engines in open, well-ventilated areas or vent the engine exhaust fumes outdoors.



1.c. Do not add the fuel near an open flame welding arc or when the engine is running. Stop the engine and allow it to cool before refueling to prevent spilled fuel from vaporizing on contact with hot engine parts and igniting. Do not spill fuel when filling tank. If fuel is spilled, wipe it up and do not start engine until fumes have been eliminated.

1.d. Keep all equipment safety guards, covers and devices in position and in good repair. Keep hands, hair, clothing and tools away from V-belts, gears, fans and all other moving parts when starting, operating or repairing equipment.

1.e. In some cases it may be necessary to remove safety guards to perform required maintenance. Remove guards only when necessary and replace them when the maintenance requiring their removal is complete. Always use the greatest care when working near moving parts.



1.f. Do not put your hands near the engine fan. Do not attempt to override the governor or idler by pushing on the throttle control rods while the engine is running.

1.g. To prevent accidentally starting gasoline engines while turning the engine or welding generator during maintenance work, disconnect the spark plug wires, distributor cap or magneto wire as appropriate.



1.h. To avoid scalding, do not remove the radiator pressure cap when the engine is hot.



### ELECTRIC AND MAGNETIC FIELDS may be dangerous

- 2.a. Electric current flowing through any conductor causes localized Electric and Magnetic Fields (EMF). Welding current creates EMF fields around welding cables and welding machines
- 2.b. EMF fields may interfere with some pacemakers, and welders having a pacemaker should consult their physician before welding.
- 2.c. Exposure to EMF fields in welding may have other health effects which are now not known.
- 2.d. All welders should use the following procedures in order to minimize exposure to EMF fields from the welding circuit:
  - 2.d.1. Route the electrode and work cables together - Secure them with tape when possible.
  - 2.d.2. Never coil the electrode lead around your body.
  - 2.d.3. Do not place your body between the electrode and work cables. If the electrode cable is on your right side, the work cable should also be on your right side.
  - 2.d.4. Connect the work cable to the workpiece as close as possible to the area being welded.
  - 2.d.5. Do not work next to welding power source.

Mar '95

POWER MIG 200

**LINCOLN**<sup>®</sup>  
ELECTRIC



### ELECTRIC SHOCK can kill.

- 3.a. The electrode and work (or ground) circuits are electrically "hot" when the welder is on. Do not touch these "hot" parts with your bare skin or wet clothing. Wear dry, hole-free gloves to insulate hands.
- 3.b. Insulate yourself from work and ground using dry insulation. Make certain the insulation is large enough to cover your full area of physical contact with work and ground.
- In addition to the normal safety precautions, if welding must be performed under electrically hazardous conditions (in damp locations or while wearing wet clothing; on metal structures such as floors, gratings or scaffolds; when in cramped positions such as sitting, kneeling or lying, if there is a high risk of unavoidable or accidental contact with the workpiece or ground) use the following equipment:**
- Semiautomatic DC Constant Voltage (Wire) Welder.
  - DC Manual (Stick) Welder.
  - AC Welder with Reduced Voltage Control.
- 3.c. In semiautomatic or automatic wire welding, the electrode, electrode reel, welding head, nozzle or semiautomatic welding gun are also electrically "hot".
- 3.d. Always be sure the work cable makes a good electrical connection with the metal being welded. The connection should be as close as possible to the area being welded.
- 3.e. Ground the work or metal to be welded to a good electrical (earth) ground.
- 3.f. Maintain the electrode holder, work clamp, welding cable and welding machine in good, safe operating condition. Replace damaged insulation.
- 3.g. Never dip the electrode in water for cooling.
- 3.h. Never simultaneously touch electrically "hot" parts of electrode holders connected to two welders because voltage between the two can be the total of the open circuit voltage of both welders.
- 3.i. When working above floor level, use a safety belt to protect yourself from a fall should you get a shock.
- 3.j. Also see Items 6.c. and 8.



### ARC RAYS can burn.

- 4.a. Use a shield with the proper filter and cover plates to protect your eyes from sparks and the rays of the arc when welding or observing open arc welding. Headshield and filter lens should conform to ANSI Z87.1 standards.
- 4.b. Use suitable clothing made from durable flame-resistant material to protect your skin and that of your helpers from the arc rays.
- 4.c. Protect other nearby personnel with suitable, non-flammable screening and/or warn them not to watch the arc nor expose themselves to the arc rays or to hot spatter or metal.



### FUMES AND GASES can be dangerous.

- 5.a. Welding may produce fumes and gases hazardous to health. Avoid breathing these fumes and gases. When welding, keep your head out of the fume. Use enough ventilation and/or exhaust at the arc to keep fumes and gases away from the breathing zone. **When welding with electrodes which require special ventilation such as stainless or hard facing (see instructions on container or MSDS) or on lead or cadmium plated steel and other metals or coatings which produce highly toxic fumes, keep exposure as low as possible and below Threshold Limit Values (TLV) using local exhaust or mechanical ventilation. In confined spaces or in some circumstances, outdoors, a respirator may be required. Additional precautions are also required when welding on galvanized steel.**
- 5.b. Do not weld in locations near chlorinated hydrocarbon vapors coming from degreasing, cleaning or spraying operations. The heat and rays of the arc can react with solvent vapors to form phosgene, a highly toxic gas, and other irritating products.
- 5.c. Shielding gases used for arc welding can displace air and cause injury or death. Always use enough ventilation, especially in confined areas, to insure breathing air is safe.
- 5.d. Read and understand the manufacturer's instructions for this equipment and the consumables to be used, including the material safety data sheet (MSDS) and follow your employer's safety practices. MSDS forms are available from your welding distributor or from the manufacturer.
- 5.e. Also see item 1.b.

Mar '95

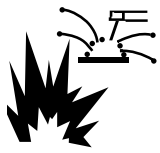

### WELDING SPARKS can cause fire or explosion.

- 6.a. Remove fire hazards from the welding area. If this is not possible, cover them to prevent the welding sparks from starting a fire. Remember that welding sparks and hot materials from welding can easily go through small cracks and openings to adjacent areas. Avoid welding near hydraulic lines. Have a fire extinguisher readily available.
- 6.b. Where compressed gases are to be used at the job site, special precautions should be used to prevent hazardous situations. Refer to "Safety in Welding and Cutting" (ANSI Standard Z49.1) and the operating information for the equipment being used.
- 6.c. When not welding, make certain no part of the electrode circuit is touching the work or ground. Accidental contact can cause overheating and create a fire hazard.
- 6.d. Do not heat, cut or weld tanks, drums or containers until the proper steps have been taken to insure that such procedures will not cause flammable or toxic vapors from substances inside. They can cause an explosion even though they have been "cleaned". For information, purchase "Recommended Safe Practices for the Preparation for Welding and Cutting of Containers and Piping That Have Held Hazardous Substances", AWS F4.1 from the American Welding Society (see address above).
- 6.e. Vent hollow castings or containers before heating, cutting or welding. They may explode.
- 6.f. Sparks and spatter are thrown from the welding arc. Wear oil free protective garments such as leather gloves, heavy shirt, cuffless trousers, high shoes and a cap over your hair. Wear ear plugs when welding out of position or in confined places. Always wear safety glasses with side shields when in a welding area.
- 6.g. Connect the work cable to the work as close to the welding area as practical. Work cables connected to the building framework or other locations away from the welding area increase the possibility of the welding current passing through lifting chains, crane cables or other alternate circuits. This can create fire hazards or overheat lifting chains or cables until they fail.
- 6.h. Also see item 1.c.

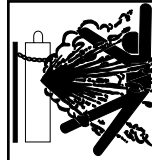

### CYLINDER may explode if damaged.

- 7.a. Use only compressed gas cylinders containing the correct shielding gas for the process used and properly operating regulators designed for the gas and pressure used. All hoses, fittings, etc. should be suitable for the application and maintained in good condition.
- 7.b. Always keep cylinders in an upright position securely chained to an undercarriage or fixed support.
- 7.c. Cylinders should be located:
  - Away from areas where they may be struck or subjected to physical damage.
  - A safe distance from arc welding or cutting operations and any other source of heat, sparks, or flame.
- 7.d. Never allow the electrode, electrode holder or any other electrically "hot" parts to touch a cylinder.
- 7.e. Keep your head and face away from the cylinder valve outlet when opening the cylinder valve.
- 7.f. Valve protection caps should always be in place and hand tight except when the cylinder is in use or connected for use.
- 7.g. Read and follow the instructions on compressed gas cylinders, associated equipment, and CGA publication P-1, "Precautions for Safe Handling of Compressed Gases in Cylinders," available from the Compressed Gas Association 1235 Jefferson Davis Highway, Arlington, VA 22202.



### FOR ELECTRICALLY powered equipment.

- 8.a. Turn off input power using the disconnect switch at the fuse box before working on the equipment.
- 8.b. Install equipment in accordance with the U.S. National Electrical Code, all local codes and the manufacturer's recommendations.
- 8.c. Ground the equipment in accordance with the U.S. National Electrical Code and the manufacturer's recommendations.

Mar '95

## PRÉCAUTIONS DE SÛRETÉ

Pour votre propre protection lire et observer toutes les instructions et les précautions de sûreté spécifiques qui paraissent dans ce manuel aussi bien que les précautions de sûreté générales suivantes:

### Sûreté Pour Soudage A L'Arc

1. Protégez-vous contre la secousse électrique:
  - a. Les circuits à l'électrode et à la pièce sont sous tension quand la machine à souder est en marche. Eviter toujours tout contact entre les parties sous tension et la peau nue ou les vêtements mouillés. Porter des gants secs et sans trous pour isoler les mains.
  - b. Faire très attention de bien s'isoler de la masse quand on soude dans des endroits humides, ou sur un plancher métallique ou des grilles métalliques, principalement dans les positions assis ou couché pour lesquelles une grande partie du corps peut être en contact avec la masse.
  - c. Maintenir le porte-électrode, la pince de masse, le câble de soudage et la machine à souder en bon et sûr état de fonctionnement.
  - d. Ne jamais plonger le porte-électrode dans l'eau pour le refroidir.
  - e. Ne jamais toucher simultanément les parties sous tension des porte-électrodes connectés à deux machines à souder parce que la tension entre les deux pinces peut être le total de la tension à vide des deux machines.
  - f. Si on utilise la machine à souder comme une source de courant pour soudage semi-automatique, ces précautions pour le porte-électrode s'appliquent aussi au pistolet de soudage.
2. Dans le cas de travail au dessus du niveau du sol, se protéger contre les chutes dans le cas où on recoit un choc. Ne jamais enrouler le câble-électrode autour de n'importe quelle partie du corps.
3. Un coup d'arc peut être plus sévère qu'un coup de soliel, donc:
  - a. Utiliser un bon masque avec un verre filtrant approprié ainsi qu'un verre blanc afin de se protéger les yeux du rayonnement de l'arc et des projections quand on soude ou quand on regarde l'arc.
  - b. Porter des vêtements convenables afin de protéger la peau de soudeur et des aides contre le rayonnement de l'arc.
  - c. Protéger l'autre personnel travaillant à proximité au soudage à l'aide d'écrans appropriés et non-inflammables.
4. Des gouttes de laitier en fusion sont émises de l'arc de soudage. Se protéger avec des vêtements de protection libres de l'huile, tels que les gants en cuir, chemise épaisse, pantalons sans revers, et chaussures montantes.
5. Toujours porter des lunettes de sécurité dans la zone de soudage. Utiliser des lunettes avec écrans latéraux dans les zones où l'on pique le laitier.
6. Eloigner les matériaux inflammables ou les recouvrir afin de prévenir tout risque d'incendie dû aux étincelles.

7. Quand on ne soude pas, poser la pince à une endroit isolé de la masse. Un court-circuit accidentel peut provoquer un échauffement et un risque d'incendie.
8. S'assurer que la masse est connectée le plus près possible de la zone de travail qu'il est pratique de le faire. Si on place la masse sur la charpente de la construction ou d'autres endroits éloignés de la zone de travail, on augmente le risque de voir passer le courant de soudage par les chaînes de levage, câbles de grue, ou autres circuits. Cela peut provoquer des risques d'incendie ou d'échauffement des chaînes et des câbles jusqu'à ce qu'ils se rompent.
9. Assurer une ventilation suffisante dans la zone de soudage. Ceci est particulièrement important pour le soudage de tôles galvanisées plombées, ou cadmiées ou tout autre métal qui produit des fumeés toxiques.
10. Ne pas souder en présence de vapeurs de chlore provenant d'opérations de dégraissage, nettoyage ou pistolage. La chaleur ou les rayons de l'arc peuvent réagir avec les vapeurs du solvant pour produire du phosgène (gas fortement toxique) ou autres produits irritants.
11. Pour obtenir de plus amples renseignements sur la sûreté, voir le code "Code for safety in welding and cutting" CSA Standard W 117.2-1974.

## PRÉCAUTIONS DE SÛRETÉ POUR LES MACHINES À SOUDER À TRANSFORMATEUR ET À REDRESSEUR

1. Relier à la terre le châssis du poste conformément au code de l'électricité et aux recommandations du fabricant. Le dispositif de montage ou la pièce à souder doit être branché à une bonne mise à la terre.
2. Autant que possible, l'installation et l'entretien du poste seront effectués par un électricien qualifié.
3. Avant de faire des travaux à l'intérieur de poste, la débrancher à l'interrupteur à la boîte de fusibles.
4. Garder tous les couvercles et dispositifs de sûreté à leur place.

Mar. '93

## MASTER TABLE OF CONTENTS FOR ALL SECTIONS

	Page
Safety .....	i-iv
<hr/>	
Installation .....	Section A
<hr/>	
Operation .....	Section B
<hr/>	
Accessories .....	Section C
<hr/>	
Maintenance .....	Section D
<hr/>	
Theory of Operation .....	Section E
<hr/>	
Troubleshooting and Repair .....	Section F
<hr/>	
Electrical Diagrams .....	Section G
<hr/>	
Parts Manual .....	.P372 & P202-H.2
<hr/>	

# TABLE OF CONTENTS - INSTALLATION SECTION -

<b>Installation</b> .....	<b>Section A</b>
Technical Specifications .....	A-2
Safety Precautions .....	A-3
Uncrating the Power MIG 200 .....	A-3
Location .....	A-3
Input Power, Grounding and Connection Diagrams .....	A-3
Dual Voltage Machine Input Connections .....	A-4
Triple Voltage Machine Input Connections .....	A-5
Output Polarity Connections .....	A-5
Gun and Cable Installation .....	A-6
Shielding Gas .....	A-6

Return to Master TOC

Return to Master TOC

Return to Master TOC

Return to Master TOC

## TECHNICAL SPECIFICATIONS – POWER MIG 200

### INPUT – SINGLE PHASE ONLY

<u>Standard Voltage/Frequency</u> 208/230/60 Hz	<u>Input Current @ 150 Amp Rated Output</u> 28/26 Amps	<u>Input Current @ 150 Amp Rated Output</u> 36/33
--	---	--

### RATED OUTPUT

<u>Duty Cycle</u> 30% 40% 60%	<u>Amps</u> 200 Amps 180 Amps 150 Amps	<u>Volts at Rated Amperes</u> 22 Volts 23 Volts 24 Volts
--	---	---

### OUTPUT

<u>Welding Current Range</u> 30 – 200 Amps	<u>Maximum Open Circuit Voltage</u> 40 Volts	<u>Welding Voltage Range</u> 13.5-22 Volts
---	---	---

### RECOMMENDED INPUT WIRE AND FUSE SIZES

Input Voltage/ Frequency (Hz)	Fuse or Breaker Size (Super Lag)	Input Ampere Rating On Nameplate	75°C Copper Wire in Conduit AWG (IEC) Sizes (For lengths up to 100 ft.)	75°C Copper Wire in Conduit AWG (IEC) Sizes (For lengths exceeding 100 ft.)
208/60 230/60	60 60	36 33	10 (6 mm <sup>2</sup> ) 10 (6 mm <sup>2</sup> )	8 (10 mm <sup>2</sup> ) 8 (10 mm <sup>2</sup> )

NOTE: Use #10 AWG Grounding Wire

### PHYSICAL DIMENSIONS

<u>Height</u> 31.79 in 808 mm	<u>Width</u> 18.88 in 480 mm	<u>Depth</u> 38.78 in 985 mm	<u>Weight</u> 210 lbs 95 kg
-------------------------------------	------------------------------------	------------------------------------	-----------------------------------

### WIRE SPEED RANGE

<u>Wire Speed</u> 50 – 700 IPM (1.27 – 17.8 m/minute)
--

POWER MIG 200





Read entire installation section before starting installation.

## SAFETY PRECAUTIONS

### ⚠ WARNING



**ELECTRIC SHOCK can kill.**

- Only qualified personnel should perform this installation.
- Only personnel that have read and understood the POWER MIG 200 Operating Manual should install and operate this equipment.
- Machine must be grounded per any national, local or other applicable electrical codes.
- The POWER MIG power switch is to be in the OFF position when installing work cable and gun and when connecting other equipment.

## UNCRATING THE POWER MIG 200

Cut banding and lift off cardboard carton. Cut banding holding the machine to the skid. Remove foam and corrugated packing material. Untape accessories from Gas Bottle Platform. Unscrew the two wood screws (at the Gas Bottle Platform) holding the machine to the skid. Roll the machine off the skid assembly.

## LOCATION

Locate the welder in a dry location where there is free circulation of clean air into the louvers in the back and out the front. A location that minimizes the amount of smoke and dirt drawn into the rear louvers reduces the chance of dirt accumulation that can block air passages and cause overheating.

## INPUT POWER, GROUNDING AND CONNECTION DIAGRAMS

### ⚠ WARNING



**ELECTRIC SHOCK can kill.**

- Do not touch electrically live parts such as output terminals or internal wiring.
- All input power must be electrically disconnected before proceeding.

1. Before starting the installation, check with the local power company if there is any question about whether your power supply is adequate for the voltage, amperes, phase, and frequency specified on the welder nameplate. Also be sure the planned installation will meet the U.S. National Electrical Code and local code requirements. This welder may be operated from a single phase line or from one phase of a two or three phase line.
2. Models that have multiple input voltages specified on the nameplate (e.g. 208/230) are shipped connected for the highest voltage. If the welder is to be operated on lower voltage, it must be reconnected according to the instructions in **Figure A.1** for dual voltage machines and **Figure A.2** for triple voltage machines.

### ⚠ WARNING

**Make certain that the input power is electrically disconnected before removing the screw on the reconnect panel access cover.**

FIGURE A.1 — Dual Voltage Machine Input Connections

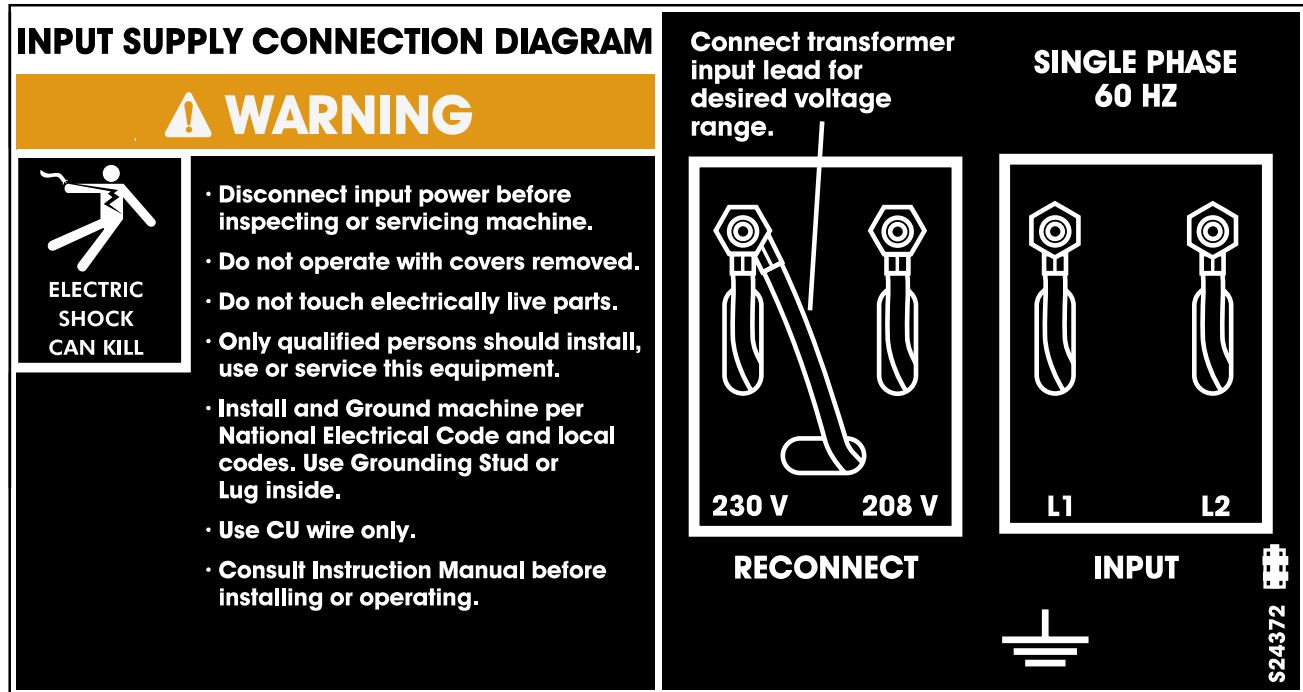

3. The 208/230 volt 60 Hz model POWER MIG is shipped with a 7 ft. input cable and plug connected to the welder.

The 230/460/575 volt 60 Hz model is not equipped with an input cable or a plug.

4. Using the instructions in **Figure A.3**, have a qualified electrician connect a receptacle (Customer Supplied) or cable to the input power lines and the system ground per the U.S. National Electrical Code and any applicable local codes. See **“Technical Specifications”** at the beginning of this chapter for proper wire sizes. For long runs over 100 feet, larger copper wires should be used. Fuse the two hot lines with super lag type fuses as shown in the following diagram. The center contact in the receptacle is for the grounding connection. A green wire in the input cable connects this contact to the frame of the welder. This ensures proper grounding of the welder frame when the welder plug is inserted into a grounded receptacle.

Return to Section TOC

Return to Master TOC

Return to Section TOC

Return to Master TOC

Return to Section TOC

Return to Master TOC

FIGURE A.2 — Triple Voltage Machine Input Connections

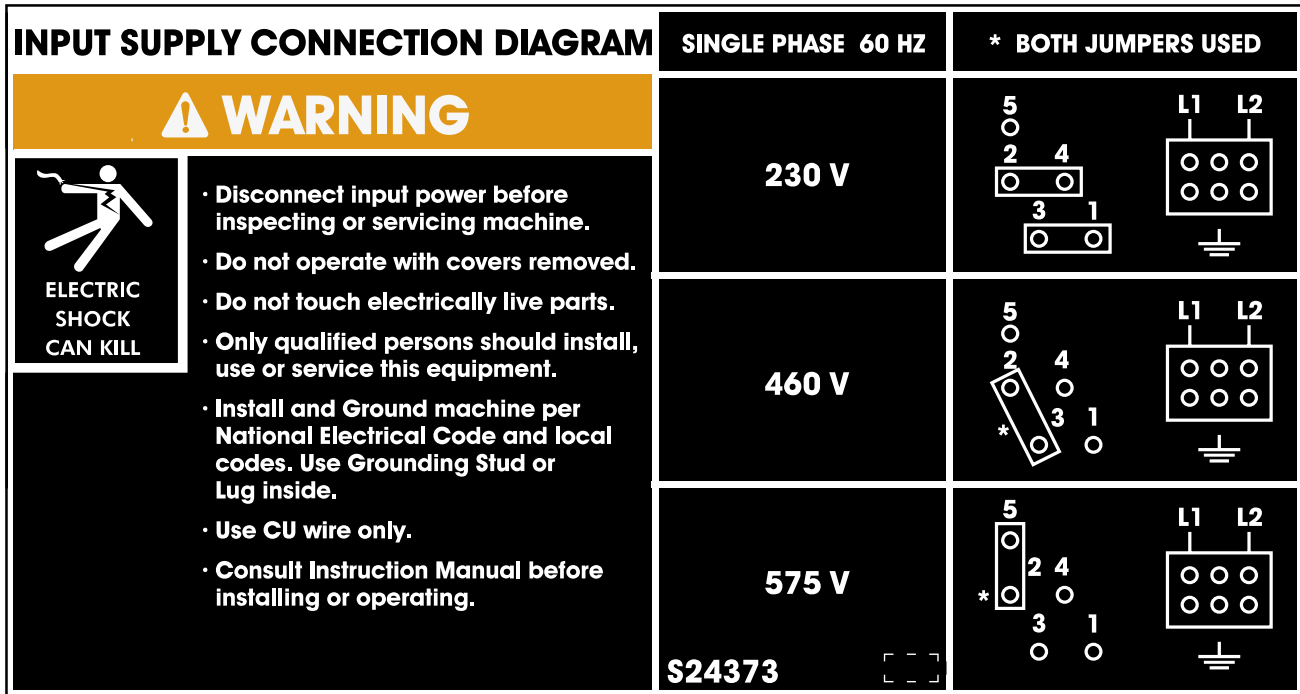
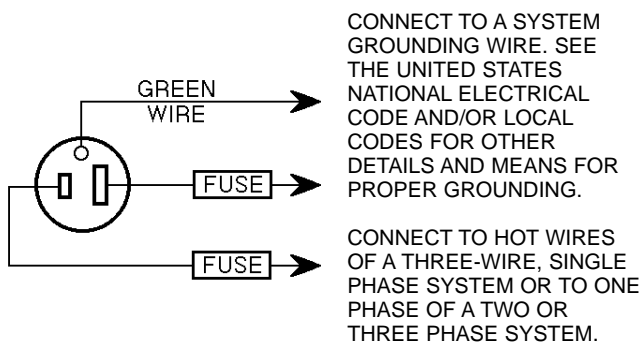

FIGURE A.3 — Receptacle Diagram



### OUTPUT POLARITY CONNECTIONS

The welder, as shipped from the factory, is connected for electrode positive (+) polarity. This is the normal polarity for GMA welding.

If negative (-) polarity is required, interchange the connection of the two cables located in the wire drive compartment near the front panel. The electrode cable, which is attached to the wire drive, is to be connected to the negative (-) labeled terminal and the work lead, which is attached to the work clamp, is to be connected to the positive (+) labeled terminal.

Return to Section TOC

Return to Section TOC

Return to Section TOC

Return to Section TOC

Return to Master TOC

Return to Master TOC

Return to Master TOC

Return to Master TOC

## GUN AND CABLE INSTALLATION

The Magnum 250L gun and cable provided with the POWER MIG 200 is factory installed with a liner for .035-.045" (0.9-1.2 mm) electrode and an .035" (0.9 mm) contact tip. Be sure that the contact tip, liner, and drive rolls all match the size of the wire being used.

### WARNING

Turn the welder power switch off before installing gun and cable.

1. Lay the cable out straight.
2. Unscrew knurled screw on the drive unit front end (inside wire feed compartment) until tip of screw no longer protrudes into gun opening as seen from front of machine.
3. Insert the male end of gun cable into the female casting through opening in front panel. Make sure connector is fully inserted and tighten knurled screw.
4. Connect the gun trigger connector from the gun and cable to the mating receptacle inside the compartment located above the gun connection made in item 3 above. Make sure that the keyways are aligned, insert and tighten retaining ring.

## SHIELDING GAS

(For Gas Metal Arc Welding Processes)

Customer must provide cylinder of appropriate type shielding gas for the process being used.

A gas flow regulator, for Argon blend gas, and an inlet gas hose are factory provided with the POWER MIG 200. When using 100% CO<sub>2</sub> an additional adapter will be required to connect the regulator to the gas bottle.

### WARNING



**CYLINDER may explode if damaged.**

- Gas under pressure is explosive. Always keep gas cylinders in an upright position and always keep chained to undercarriage or stationary support. See American National Standard Z-49.1, "Safety in Welding and Cutting" published by the American Welding Society.

Install shielding gas supply as follows:

1. Set gas cylinder on rear platform of POWER MIG 200. Hook chain in place to secure cylinder to rear of welder.

2. Remove the cylinder cap. Inspect the cylinder valves and regulator for damaged threads, dirt, dust, oil or grease. Remove dust and dirt with a clean cloth.

**DO NOT ATTACH THE REGULATOR IF OIL, GREASE OR DAMAGE IS PRESENT!** Inform your gas supplier of this condition. Oil or grease in the presence of high pressure oxygen is explosive.

3. Stand to one side away from the outlet and open the cylinder valve for an instant. This blows away any dust or dirt which may have accumulated in the valve outlet.

### WARNING

Be sure to keep your face away from the valve outlet when "cracking" the valve.

4. Attach the flow regulator to the cylinder valve and tighten the union nut(s) securely with a wrench.

**NOTE:** If connecting to 100% CO<sub>2</sub> cylinder, an additional regulator adapter must be installed between the regulator and cylinder valve. If adapter is equipped with a plastic washer, be sure it is seated for connection to the CO<sub>2</sub> cylinder.

5. Attach one end of the inlet gas hose to the outlet fitting of the flow regulator, the other end to the POWER MIG 200 rear fitting, and tighten the union nuts securely with a wrench.
6. Before opening the cylinder valve, turn the regulator adjusting knob counterclockwise until the adjusting spring pressure is released.
7. Standing to one side, open the cylinder valve slowly a fraction of a turn. When the cylinder pressure gauge pointer stops moving, open the valve fully.

### WARNING

Never stand directly in front of or behind the flow regulator when opening the cylinder valve. Always stand to one side.

8. The flow regulator is adjustable. Adjust it to the flow rate recommended for the procedure and process being used before making the weld.

# TABLE OF CONTENTS - OPERATION SECTION -

Return to Master TOC

Return to Master TOC

Return to Master TOC

Return to Master TOC

<b>Operation</b>	<b>Section B</b>
Warnings	B-2
Product Description	B-3
Recommended Processes and Equipment	B-3
Welding Capability	B-3
Limitations	B-3
Description of Controls	B-3
Wire Drive Roll	B-3
Wire Size Conversion Parts	B-3
Procedure for Changing Drive and Idle Roll Sets	B-4
Wire Reel Loading	B-4
To Start the Welder	B-4
Feeding Wire Electrode	B-5
Idle Roll Pressure Setting	B-5
Making a Weld	B-5
Avoiding Wire Feeding Problems	B-6
Fan Control	B-6
Input Line Voltage Variations	B-6
Wirefeed Overload Protection	B-6
Welding Thermal Overload Protection	B-6

Read entire Operation section before operating the POWER MIG 200.

## WARNING



**ELECTRIC SHOCK** can kill.

- Do not touch electrically live parts or electrode with skin or wet clothing. Insulate yourself from work and ground.
- Always wear dry insulating gloves.



**FUMES AND GASES** can be dangerous.

- Keep your head out of fumes.
- Use ventilation or exhaust to remove fumes from breathing zone.

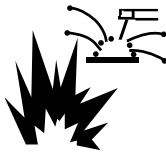

**WELDING SPARKS** can cause fire or explosion.

- Keep flammable material away.
- Do not weld on closed containers.



**ARC RAYS** can burn eyes and skin.

- Wear eye, ear and body protection.

Observe all safety information throughout this manual.

## PRODUCT DESCRIPTION

The POWER MIG™ 200 is a complete semiautomatic DC voltage arc welding machine built to meet NEMA specifications. It combines a tapped transformer voltage power source with a constant speed wire feeder to form a reliable robust performance welding system. A simple control scheme, consisting of continuous full range wire feed speed control, and 7 output voltage tap selections provides versatility with ease of use and accuracy.

Other features include a 2" (51 mm) O.D. wire reel spindle with adjustable brake, an integral gas cylinder mounting undercarriage, an adjustable Argon blend flow regulator with cylinder pressure gauge and inlet hose, a 12 ft. (3.6 m) Magnum 250L GMAW gun and cable with fixed (flush) nozzle, a 7 ft. (2.1 m) power cable with plug, and a 10 ft. (3.0 m) work cable with clamp.

Optional Spool Gun and Adapter kit, Dual Cylinder Mounting kit and Aluminum Feeding Kit for push feeding with standard built in feeder are also available.

## RECOMMENDED PROCESSES AND EQUIPMENT

The POWER MIG 200 is recommended for GMA welding processes using 10 to 44 lb (4.5 to 20 kg) 2" (51 mm) I.D. spools or Readi-Reel® coils (with optional adapter) of .025" through .045" (0.6 – 1.2 mm) solid steel, .035" (0.9 mm) stainless, 3/64" (1.2 mm) aluminum and .045" (1.2 mm) Outershield®; as well as .035" (0.9 mm) and .045" (1.2 mm) Innershield® self-shielding electrodes.

The POWER MIG is factory equipped to feed .035" (0.9 mm) electrodes. It also includes a 200A, 60% duty cycle (or 250A, 40% duty cycle) rated, 12 ft. (3.6 m) GMAW gun and cable assembly equipped for these wire sizes. Use of GMAW processes requires a supply of shielding gas.

## WELDING CAPABILITY

The POWER MIG 200 is rated at 200 amps @ 22 volts, at a 30% duty cycle based on a ten minute cycle time. It is capable of higher duty cycles at lower output currents. The tapped transformer design makes it well suited for use with most portable or in-plant generating systems.

## LIMITATIONS

The output voltage/current of the POWER MIG 200 is subject to vary if the input power to the machine varies, due to its tapped transformer power topology. In some cases an adjustment of WFS preset and/or voltage tap selection may be required to accommodate a significant drift in input power.

## DESCRIPTION OF CONTROLS

**Power ON/OFF Switch** — Place the lever in the "ON" position to energize the POWER MIG 200. See Figure B.1.

**Voltage Control** — Seven voltage tap selections are provided Labeled "A" (minimum voltage) through "G" (maximum voltage). It should only be adjusted when not welding. The control selection can be preset to the setting specified on the Procedure Decal on the inside of the wire compartment door. See Figure B.1.

**Wire Speed Control** — This controls the wire feed speed from 50 – 700 inches per minute (1.2 – 17.8 m/min). Wire speed is not affected when changes are made in the voltage control. See Figure B.1.

Figure B.1. Control Locations

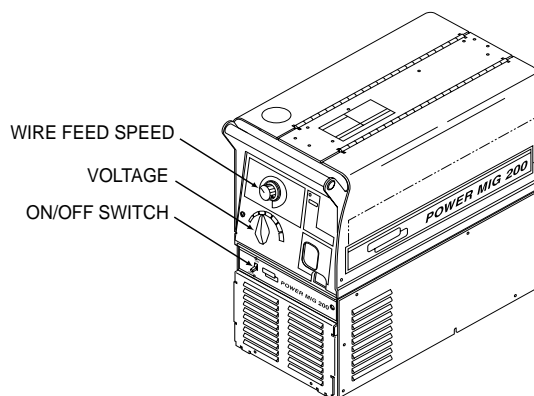

## WIRE DRIVE ROLL

The drive rolls installed with the POWER MIG each have two grooves, both for .030-.035" (0.8-0.9 mm) solid steel electrode. Drive roll size is indicated by the stenciling on the exposed side of the drive roll. If feeding problems occur, then the drive roll may be reversed or changed. See "*Procedure for Changing Drive Roll*" in this section.

## WIRE SIZE CONVERSION PARTS

The POWER MIG 200 is rated to feed .025 through .045" (0.6-1.2 mm) solid or cored electrode sizes. The drive roll kits and Magnum 250L gun and cable parts are available to feed different sizes and types of electrodes. See *Accessories section*.

POWER MIG 200





## PROCEDURE FOR CHANGING DRIVE AND IDLE ROLL SETS

1. Turn off the power source.
2. Release the pressure on the idle roll by swinging the adjustable pressure arm down toward the back of the machine. Lift the cast idle roll assembly and allow it to sit in an upright position..
3. Remove the outside wire guide retaining plate by loosening the two large knurled screws.
4. Wiggle both the metal idle and drive rolls off of their plastic hubs.
5. Remove the inside wire guide plate.
6. Replace the drive and idle rolls and inside wire guide with a set marked for the new wire size.  
**NOTE:** Be sure that the gun liner and contact tip are also sized to match the selected wire size.
7. Manually feed the wire from the wire reel, over the drive roll groove and through the wire guide and then into the brass bushing of the gun and cable assembly.
8. Replace the outside wire guide retaining plate by tightening the two large knurled screws. Reposition the adjustable pressure arm to its original position to apply pressure. Adjust pressure as necessary.

## WIRE REEL LOADING - READI-REELS, SPOOLS OR COILS

### To Mount a 30 Lb. (14 kg) Read-Reel Package (Using the Molded Plastic K363-P Read-Reel Adapter:)

1. Open the Wire Drive Compartment Door.
2. Depress the Release Bar on the Retaining Collar and remove it from the spindle.
3. Place the Optional Adapter on the spindle
4. Re-install the Retaining Collar. Make sure that the Release Bar "pops up" and that the collar retainers fully engage the retaining ring groove on the spindle.
5. Rotate the spindle and adapter so the retaining spring is at the 12 o'clock position.
6. Position the Read-Reel so that it will rotate in a direction when feeding so as to be de-reeled from top of the coil.

7. Set one of the Read-Reel inside cage wires on the slot in the retaining spring tab.
8. Lower the Read-Reel to depress the retaining spring and align the other inside cage wires with the grooves in the molded adapter.
9. Slide cage all the way onto the adapter until the retaining spring "pops up" fully.

### **CAUTION**

CHECK TO BE SURE THE RETAINING SPRING HAS FULLY RETURNED TO THE LOCKING POSITION AND HAS SECURELY LOCKED THE READI-REEL CAGE IN PLACE. RETAINING SPRING MUST REST ON THE CAGE, NOT THE WELDING ELECTRODE.

10. To remove Read-Reel from Adapter, depress retaining spring tab with thumb while pulling the Read-Reel cage from the molded adapter with both hands. Do not remove adapter from spindle.

FIGURE B.2

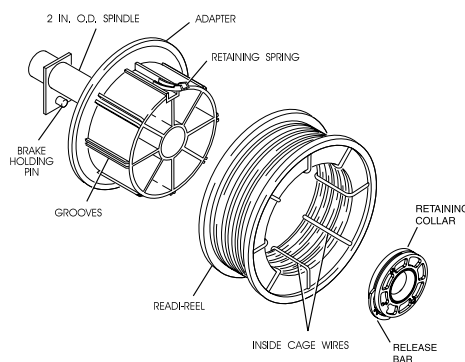

### To Mount 10 to 44 Lb. (4.5-20 kg) Spools (12"/300 mm Diameter) or 14Lb.(6 Kg) Innershield Coils:

(For 13-14 lb. (6 Kg) Innershield coils, a K435 Coil Adapter must be used).

1. Open the Wire Drive Compartment Door
2. Depress the Release Bar on the Retaining Collar and remove it from the spindle.
3. Place the spool on the spindle making certain the spindle brake pin enters one of the holes in the back side of the spool (Note: an arrow mark on the spindle lines up with the brake holding pin to assist in lining up a hole). Be certain the wire comes off the reel in a direction so as to de-reel from the top of the coil.
4. Re-install the Retaining Collar. Make sure that the Release Bar "pops up" and that the collar retainers fully engage the retaining ring groove on the spindle.

## TO START THE WELDER

Turn the "Power Switch" switch to "ON". This lights the red LED display lights. With the desired voltage and wire speed selected, operate the gun trigger for welder output and to energize the wire feed motor.



## FEEDING WIRE ELECTRODE

### WARNING

When triggering, the electrode and drive mechanism are electrically “hot” relative to work and ground and remain “hot” several seconds after the gun trigger is released.

**NOTE:** Check that drive rolls, guide plates and gun parts are proper for the wire size and type being used. Refer to **Table C.1** in Accessories section.

1. Turn the Readi-Reel or spool until the free end of the electrode is accessible.
2. While securely holding the electrode, cut off the bent end and straighten the first six inches. (If the electrode is not properly straightened, it may not feed properly through the wire drive system).
3. Release the pressure on the idle roll by swinging the adjustable pressure arm down toward the back of the machine. Lift the cast idle roll assembly and allow it to sit in an upright position. Leave the outer wire guide plate installed. Manually feed the wire through the incoming guide bushing and through the guide plates (over the drive roll groove). Push a sufficient wire length to assure that the wire has fed into the gun and cable assembly without restriction. Reposition the adjustable pressure arm to its original position to apply pressure to the wire.
4. Press gun trigger to feed the electrode wire through the gun.

## IDLE ROLL PRESSURE SETTING

The optimum idle roll pressure varies with type of wire, wire diameter, surface conditions, lubrication, and hardness. As a general rule, hard wires may require greater pressure, and soft, or aluminum wire, may require less pressure than the factory setting. The optimum idle roll setting can be determined as follows:

1. Press end of gun against a solid object that is electrically isolated from the welder output and press the gun trigger for several seconds.
2. If the wire “birdnests”, jams or breaks at the drive roll, the idle roll pressure is too great. Back the adjustment knob out 1/2 turn, run new wire through gun, and repeat above steps.
3. If the only result was drive roll slippage, loosen the adjustment knob on the conductor plate and pull the gun cable forward about 6" (15 cm). There should be a slight waviness in the expose wire. If there is not waviness, the pressure is too low. Tighten the adjustment knob 1/4 turn, reinstall the gun cable and repeat the above steps.

## MAKING A WELD

1. Check that the electrode polarity is correct for the process being used, then turn the power switch ON.
2. Set desired arc voltage tap and wire speed for the particular electrode wire, material type and thickness, and gas (for GMAW) being used. Use the Application Chart on the door inside the wire compartment as a quick reference for some common welding procedures.
3. Press the trigger to feed the wire electrode through the gun and cable and then cut the electrode within approximately 3/8" (10 mm) of the end of the contact tip [3/4" (20 mm) Outershield®].
4. If welding gas is to be used, turn on the gas supply and set the required flow rate (typically 25-35 CFH; 12-16 liters/min).
5. When using Innershield electrode, the gas nozzle may be removed from the insulation on the end of the gun and replaced with the gasless nozzle. This will give improved visibility and eliminate the possibility of the gas nozzle overheating.
6. Connect work cable to metal to be welded. Work clamp must make good electrical contact to the work. The work must also be grounded as stated in “Arc Welding Safety Precautions”.

### WARNING

When using an open arc process, it is necessary to use correct eye, head, and body protection.

7. Position electrode over joint. End of electrode may be lightly touching the work.
8. Lower welding helmet, close gun trigger, and begin welding. Hold the gun so the contact tip to work distance is about 3/8" (10 mm) [3/4" (20 mm) for Outershield].
9. To stop welding, release the gun trigger and then pull the gun away from the work after the arc goes out.
10. When no more welding is to be done, close valve on gas cylinder (if used), momentarily operate gun trigger to release gas pressure, and turn off POWER MIG 200.

POWER MIG 200

**LINCOLN**<sup>®</sup>  
ELECTRIC

## AVOIDING WIRE FEEDING PROBLEMS

Wire feeding problems can be avoided by observing the following gun handling procedures:

1. Do not kink or pull cable around sharp corners.
2. Keep the gun cable as straight as possible when welding or loading electrode through cable.
3. Do not allow dolly wheels or trucks to run over cables.
4. Keep cable clean by following maintenance instructions.
5. Use only clean, rust-free electrode. The Lincoln electrodes have proper surface lubrication.
6. Replace contact tip when the arc starts to become unstable or the contact tip end is fused or deformed.
7. Keep wire reel spindle brake tension to minimum required to prevent excess reel over-travel which may cause wire "loop-offs" from coil.
8. Use proper drive rolls and wire drive idle roll pressure for wire size and type being used.

## FAN CONTROL

The fan is designed to come on when input power is applied to the POWER MIG 200 and go off when power is removed.

## INPUT LINE VOLTAGE VARIATIONS

**High Line Voltage** — Higher than rated input voltage will result in output voltages higher than normal for a given tap setting. If your input line is high, you may want to select a lower voltage tap than given on the recommended procedure chart.

**Low Line Voltage** — You may not be able to get maximum output from the machine if the line voltage is less than rated input. The unit will continue to weld, but the output may be less than normal for a given tap setting. If your input line is low, you may want to select a higher voltage tap than given on the recommended procedure chart.

## WIRE FEED OVERLOAD PROTECTION

The POWER MIG has solid state overload protection of the wire drive motor. If the motor becomes overloaded, the protection circuitry turns off the wire feed speed and gas solenoid. Check for proper size tip, liner, and drive rolls, for any obstructions or bends in the gun cable, and any other factors that would impede the wire feeding. To resume welding, simply pull the trigger. There is no circuit breaker to reset, as the protection is done with reliable solid state electronics.

## WELDING THERMAL OVERLOAD PROTECTION

The POWER MIG 200 has built-in protective thermostats that respond to excessive temperature. They open the wire feed and welder output circuits if the machine exceeds the maximum safe operating temperature because of a frequent overload, or high ambient temperature plus overload. The thermostats automatically reset when the temperature reaches a safe operating level and welding and feeding are allowed again, when gun is retriggered.

TABLE B.1.

Steel Thickness Wire Feed Speed/Voltage Tap Settings														
Wire Dia.	Gas Type	Wire Type	Polarity	18 gage	16 gage	14 gage	12 gage	10 gage	3/16	1/4	5/16	3/8	1/2	
Outershield	3/4" ESO†													
	.035	75Ar/25CO <sub>2</sub>	OS71M	DC+				250/D	300/E	350/F	500/G	*500/G		
	.035	100%CO <sub>2</sub>	OS71M	DC+					300/E	350/F	500/G			
	.045	75Ar/25CO <sub>2</sub>	OS71M	DC+						200/E	225/F	250/G	250/G	*250/G
Innershield	3/8" ESO†													
	.035	NoneReq'd	NR-211MP	DC-	50/B	70/B	80/B	90/C	100/C					
	.045	NoneReq'd	NR-211MP	DC-				50/B	70/C	90/C	110/D	*130/E		
	.045	NoneReq'd	NR212	DC-	40/B	50/B	60/B	65/C	70/C	90/C	110/D	*130/E	*150/E	*150/E
* Note- Requires Multiple Pass								.035 & .045 NR-211 MP is only						
† Electrical Stickout								recommended for a maximum of 5/16"						

POWER MIG 200



Return to Section TOC  
Return to Master TOC

Return to Section TOC  
Return to Master TOC

Return to Section TOC  
Return to Master TOC

Return to Section TOC  
Return to Master TOC

# TABLE OF CONTENTS - ACCESSORIES SECTION -

Return to Master TOC

Return to Master TOC

Return to Master TOC

Return to Master TOC

<b>Accessories</b>	<b>Section C</b>
Drive Roll Kits	C-2
3/64" (1.2mm) Aluminum Feeding Kit (K1703-1)	C-2
K363P Readi-Reel Adapter	C-2
Dual Cylinder Mounting Kit	C-2
Alternative Magnum GMAW Gun and Cable Assemblies	C-2
Magnum Gun Connection Kit	C-2
Spool Gun and Adapter Kit	C-2
Making a Weld (with the Spool Gun Adapter Kit)	C-3

## DRIVE ROLL KITS

Refer to Table C.1 for various drive roll kits that are available for the POWER MIG 200. The item in **Bold** is supplied standard with the POWER MIG 200.

Wire	Size	Drive Roll Kit
Solid Steel	.023"-.030" (0.6-0.8 mm)	KP1696-030S
	<b>.035" (0.9 mm)</b>	<b>KP1696-035S</b>
	.045" (1.2 mm)	KP1696-045S
Cored	.035" (0.9 mm)	KP1697-035C
	.045" (1.2 mm)	KP1697-045C
Aluminum	3/64" (1.2 mm)	KP1695-3/64A

TABLE C.1

## 3/64" (1.2 mm) ALUMINUM FEEDING KIT (K1703-1)

This kit helps push feeding aluminum through standard machine feeder and gun. It provides gun and wire drive conversion parts to weld with 3/64" (1.2 mm) aluminum wire. 5356 alloy aluminum wire is recommended for best push feeding performance.

Kit includes drive rolls and wire guide plate for the wire drive, liner and two contact tips for the gun, along with installation instructions.

## K363P READI-REEL ADAPTER

The K363P Readi-Reel Adapter mounts to the 2" spindle. It is needed to mount the 22-30 lb. Readi-Reels.

## DUAL CYLINDER MOUNTING KIT (K1702-1)

Permits stable side-by-side mounting of two full size (9" dia. x 5' high) gas cylinders with "no lift" loading. Simple installation and easy instructions provided. Includes upper and lower cylinder supports, wheel axles and mounting hardware.

## ALTERNATIVE MAGNUM GMAW GUN AND CABLE ASSEMBLIES

The following Magnum 250L gun and cable assemblies are separately available for use with the POWER MIG 200. Each is rated 200 amps 60% duty cycle and is equipped with the integrated connector, twist-lock trigger connector, fixed nozzle and insulator, and includes a liner, diffuser, and contact tips for the wire sizes specified:

Length	Part No.	English Wire Size	Metric Wire Size
10' (3.0 m)	K533-1	.035 – .045"	0.9 – 1.2 mm
12' (3.6 m)	K533-2		
15' (4.5 m)	K533-3		
10' *3.0 m)	K533-4	.025 – .030"	0.6 – 0.8 mm
12' (3.6 m)	K533-5		
15' (4.5 m)	K533-6		

TABLE C.2

## MAGNUM GUN CONNECTION KIT (Optional K466-6)

Using the optional K466-6 Magnum Connection kit for the POWER MIG permits use of standard Magnum 200, 300 or 400 gun and cable assemblies.

## SPOOL GUN AND ADAPTER KIT (K1809-1)

The K1809-1 includes the Magnum 250SG Spool gun and the adapter kit for connecting the spool gun to the Power MIG 200.

The Adapter Kit provides toggle switch selection between the machine's use with its feeder gun or the spool gun for same polarity welding with different wire and gas processes.

The kit includes a spool gun adapter module assembly with a single connecting plug and trigger switch, a rear gas inlet, fitting hose, solenoid valve assembly, and mounting hardware with installation and operation instructions.

### WARNING

Remove all input power to the POWER MIG 200 before installing the Spool Gun and Kit.

## MAKING A WELD WITH THE SPOOL GUN ADAPTER KIT AND SPOOL GUN INSTALLED

### CAUTION

In either toggle switch position, closing either gun trigger will cause the electrode of both guns to be electrically “HOT”. Be sure unused gun is positioned so electrode or tip will not contact metal case or other metal common to work.

---

1. Setting spool gun selector switch to the “Normal” position and pulling the trigger for the built-in feeder gun.
  - Disables spool gun operation and spool gun gas solenoid valve.
  - Closing feeder gun trigger starts feeder gun welding and makes both electrodes electrically “HOT”.
2. Setting spool gun selector switch to the Spool Gun Position and pulling SPOOL GUN Trigger.
  - Disables built-in feeder gun operation and machine gas solenoid valve.
  - Enables spool gun operation and spool gun gas solenoid valve.
  - Closing spool gun trigger starts spool gun welding and makes both electrodes electrically “HOT”.
3. Operation with POWER MIG 200:
  - Turn the POWER MIG-200 input power ON.
  - Adjusting the voltage tap control will increase or decrease your welding voltage.
  - Adjusting the wire speed control on the spool gun will increase or decrease the spool gun wire feed speed. NOTE: Adjusting the wire feed speed control on the Power Mig Panel has no affect on the spool gun’s wire feed speed.
4. Refer to the procedure decal on the Power Mig for initial aluminum settings. Make a test weld to determine the final settings.

5. To return to normal POWER MIG 200 welding, release the spool gun trigger set spool gun selector switch to normal and reset feeder gun voltage procedure setting if necessary.

Return to Section TOC  
Return to Master TOC  
Return to Section TOC  
Return to Master TOC  
Return to Section TOC  
Return to Master TOC  
Return to Section TOC  
Return to Master TOC



# TABLE OF CONTENTS - MAINTENANCE SECTION -

<b>Maintenance</b> .....	<b>Section D</b>
Safety Precautions .....	D-2
General Maintenance .....	D-2
Drive Rolls and Guide Plates .....	D-2
Contact Tip and Gas Nozzle Installation .....	D-2
Gun Tubes and Nozzles .....	D-2
Gun Cable Cleaning .....	D-2
Liner Removal and Replacement .....	D-3
Gun Handle Disassembly .....	D-4
Accessories and replacement parts for Magnum 250L Gun & Cable Assemblies .....	D-4
Major Component Location .....	D-5

Return to Master TOC

Return to Master TOC

Return to Master TOC

Return to Master TOC

## SAFETY PRECAUTIONS

### ⚠ WARNING



#### ELECTRIC SHOCK can kill.

- Have an electrician install and service this equipment.
- Turn the input power off at the fuse box before working on equipment
- Do not touch electrically hot parts.

(READ THE SAFETY PRECAUTIONS IN THE FRONT OF THIS MANUAL BEFORE WORKING ON THIS MACHINE.)

## GENERAL MAINTENANCE

In extremely dusty locations, dirt may clog the air passages causing the welder to run hot. Blow dirt out of the welder with low-pressure air at regular intervals to eliminate excessive dirt and dust build-up on internal parts.

The fan motors have sealed ball bearings which require no service.

## DRIVE ROLLS AND GUIDE PLATES

After every coil of wire, inspect the wire drive mechanism. Clean it as necessary by blowing with low pressure compressed air. Do not use solvents for cleaning the idle roll because it may wash the lubricant out of the bearing. All drive rolls are stamped with the wire sizes they will feed. If a wire size other than that stamped on the roll is used, the drive roll must be changed.

For instructions on replacing or changing drive roll, see *"Wire Drive Rolls"* in Operation section.

## CONTACT TIP AND GAS NOZZLE INSTALLATION

1. Choose the correct size contact tip for the electrode being used (wire size is stenciled on the side of the contact tip) and screw it snugly into the gas diffuser.
2. Screw the appropriate fixed gas nozzle fully onto the diffuser. Either the standard .50" (12.7 mm) flush nozzle or other optional flush or recessed (spray arc) nozzle sizes may be used. (See **Table D.2** in this section.)
3. If using optional adjustable slip-on nozzles, see **Table D.2** in this section.
  - Be sure the nozzle insulator is fully screwed onto the gun tube and does not block the gas holes in the diffuser.
  - Slip the appropriate gas nozzle onto the nozzle insulator. Either a standard .50" (12.7 mm) or optional .62" (15.9 mm) I.D. slip-on gas nozzle may be used and should be selected based on the welding application.
    - \* Adjust the gas nozzle as appropriate for the GMAW process to be used. Typically, the contact tip end should be flush to .12" (3.2 mm) extended for the short-circuiting transfer process and .12" (3.2 mm) recessed for spray transfer.

## GUN TUBES AND NOZZLES

1. Replace worn contact tips as required.
2. Remove spatter from inside of gas nozzle and from tip after each 10 minutes of arc time or as required.

## GUN CABLE CLEANING

To help prevent feeding problems, clean cable liner after using approximately 300 pounds (136 kg) of electrode. Remove the cable from the wire feeder and lay it out straight on the floor. Remove the contact tip from the gun. Using an air hose and only partial pressure, gently blow out the cable liner from the gas diffuser end.



## ⚠ CAUTION

Excessive pressure at the start may cause the dirt to form a plug.

Flex the cable over its entire length and again blow out the cable. Repeat this procedure until no further dirt comes out. If this has been done and feed problems are experienced, try liner replacement, and refer to the trouble shooting section on *rough wire feeding*.

## LINER REMOVAL AND REPLACEMENT

NOTE: Changing the liner for a different wire size requires replacement of the gas diffuser per Table D.1 to properly secure the different liner.

4. Insert a new untrimmed liner into the connector end of the cable. Be sure the liner bushing is stencilled appropriately for the wire size being used.
5. Fully seat the liner bushing into the connector. Tighten the set screw on the brass cable connector. The gas diffuser, at this time, should **not** be installed onto the end of the gun tube.
6. With the gas diffuser still removed from the gun tube, be sure the cable is straight, and then trim the liner to the length shown in Figure D.1. Remove any burrs from the end of the liner.
7. Screw the gas diffuser onto the end of the gun tube and securely tighten. Be sure the gas diffuser is correct for the liner being used. (See table and diffuser stencil.)

TABLE D.1

Diameter of Electrodes Used	Replacement Liner Part Number	Size Stencilled on End of Liner Bushing	Fixed Nozzle Gas Diffuser Part No. (and Stencil)	Adjustable Nozzle Gas Diffuser Part No. (and Stencil)
.025-.030" Steel (0.6-0.8 mm)	M16087-2	.030 (0.8 mm)	S19418-3	S19418-2
.035-.045" Steel (0.9-1.2 mm)	M16087-1	.045 (1.2 mm)	S19418-3	S19418-1
3/64" Aluminum (1.2 mm)	M17714-1	3/64" (1.2 mm)	S19418-3	S19418-1

## LINER REMOVAL, INSTALLATION AND TRIMMING INSTRUCTIONS FOR MAGNUM 250L

NOTE: The variation in cable lengths prevents the interchangeability of liners between guns. Once a liner has been cut for a particular gun, it should not be installed in another gun unless it can meet the liner cut-off length requirement. Liners are shipped with the jacket of the liner extended the proper amount.

1. Remove the gas nozzle and nozzle insulator, if used, to locate the set screw in the gas diffuser which is used to hold the old liner in place. Loosen the set screw with a 5/64" (2.0 mm) Allen wrench.
2. Remove the gas diffuser from the gun tube.
3. Lay the gun and cable out straight on a flat surface. Loosen the set screw located in the brass connector at the feeder end of the cable and pull the liner out of the cable.

8. Tighten the set screw in the side of the gas diffuser against the cable liner using a 5/64" (2.0 mm) Allen wrench.

FIGURE D.1

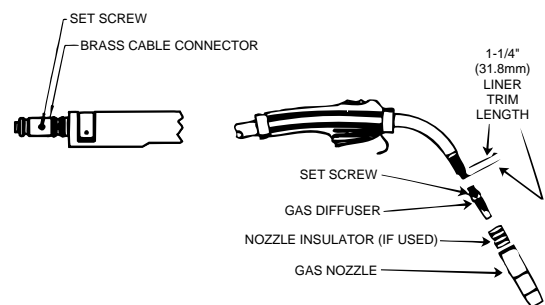

## ⚠ CAUTION

This screw should only be gently tightened. Overtightening will split or collapse the liner and cause poor wire feeding.

## GUN HANDLE DISASSEMBLY

The internal parts of the gun handle may be inspected or serviced if necessary.

The gun handle consists of two halves that are held together with a collar on each end. To open up the handle, turn the collars approximately 60 degrees counterclockwise (the same direction as removing a right hand thread) until the collar reaches a stop. Then pull the collar off the gun handle. If the collars are difficult to turn, position the gun handle against a corner, place a screwdriver against the tab on the collar and give the screwdriver a sharp blow to turn the collar past an internal locking rib.

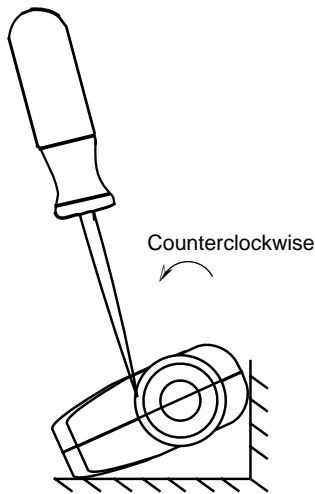

TABLE D.2  
ACCESSORIES AND EXPENDABLE REPLACEMENT PARTS  
FOR MAGNUM 250L GUN AND CABLE ASSEMBLIES

Description	Part No.	English Size	Metric Size	
CABLE LINER For 15' (4.5 m) or shorter Cable	M16087-2	.025 – .030"	0.6 – 0.8 mm	
	M16087-1	.035 – .045"	0.9 – 1.2 mm	
	M17714-1	3/64" (Alum. wire)	1.2 mm (Alum. wire)	
CONTACT TIPS Standard Duty	S19391-6	.025"	0.6 mm	
	S19391-7	.030"	0.8 mm	
	S19391-1 *	.035"	0.9 mm	
	S19391-2	.045"	1.2 mm	
	Heavy Duty	S19392-1	.035"	0.9 mm
		S19292-2	.045"	1.2 mm
	Tapered	S19393-5	.025"	0.6 mm
		S19393-6	.030"	0.8 mm
		S19393-1	.035"	0.9 mm
		S19393-2	.045"	1.2 mm
Tab (For Aluminum)	S18697-46	3/64" (Alum. Wire)	1.2 mm (Alum. Wire)	
GAS NOZZLES Fixed (Flush)  (Recessed)  Requires: Gas Diffuser As'bly  Adjustable Slip-On  Requires: Nozzle Insulator As'bly  Requires: Gas Diffuser As'bly  Gasless Nozzle (For Innershield)	M16081-1	3/8"	9.5 mm	
	M16081-2 *	1/2"	12.7 mm	
	M16081-3	5/8"	15.9 mm	
	M16080-1	3/8"	9.5 mm	
	M16080-2	1/2"	12.7 mm	
	M16080-3	5/8"	15.9 mm	
	S19418-3 *	.025 – .045"	0.6 – 1.2 mm	
	M16093-2	1/2"	12.7 mm	
	M16093-1	5/8"	15.9 mm	
	S19417-1			
	S19418-2	.025 – .030"	0.6 – 0.8 mm	
	S19418-1	.035 – .045"	0.9 – 1.2 mm	
	M16938 Δ			
GUN TUBE ASSEMBLIES Standard (60°) 45°	S18920 *			
	S19890			

\* Included with POWER MIG 200

Δ Requires S19418-1 Gas Diffuser Assembly.

- 1. Case Front Assembly
- 2. Rear Panel Assembly
- 3. Center Assembly
- 4. Wire Drive Assembly
- 5. Base & Power Component Assembly
- 6. Covers Assembly

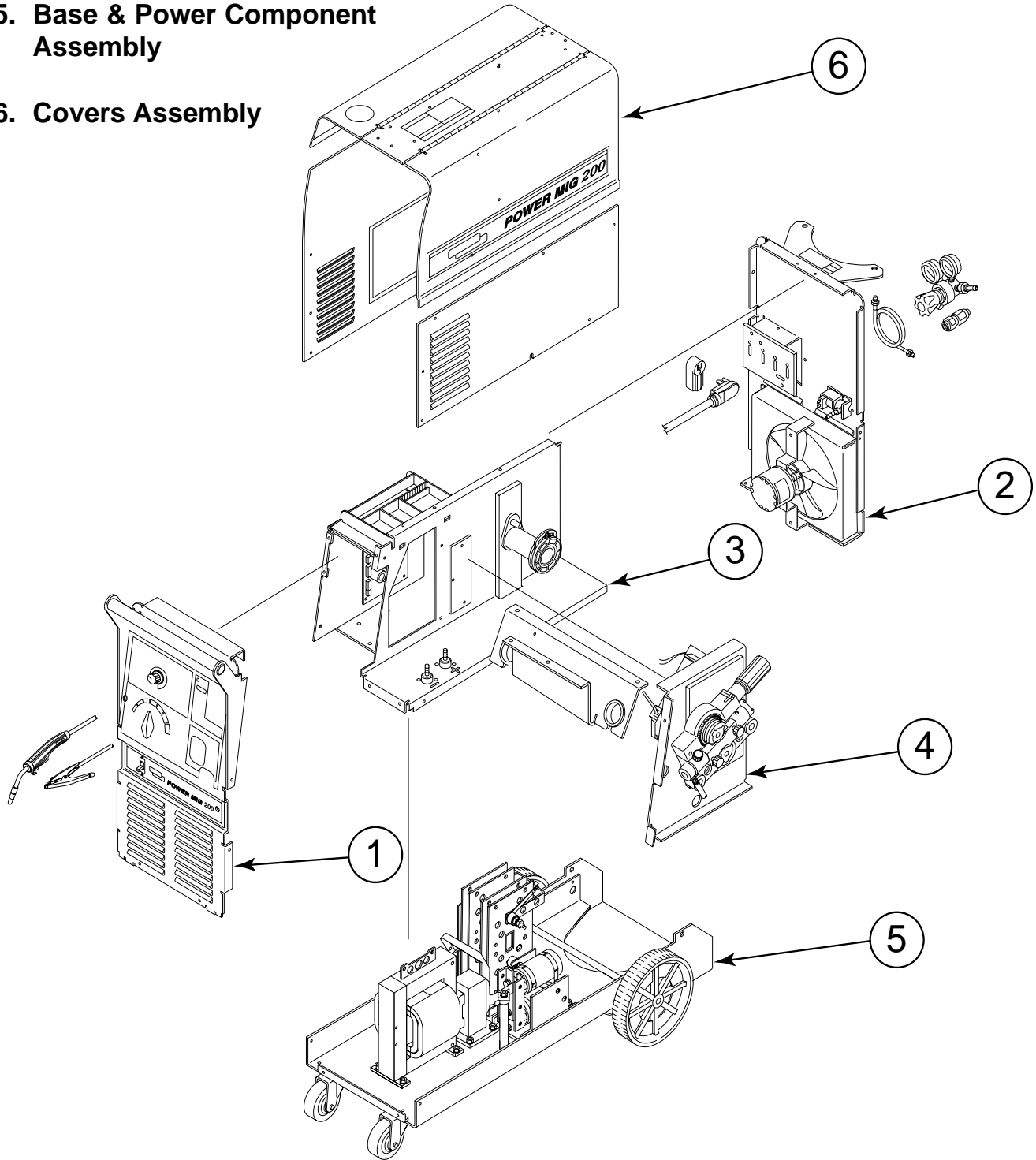

POWER MIG 200



Return to Section TOC

Return to Section TOC

Return to Section TOC

Return to Section TOC

Return to Master TOC

Return to Master TOC

Return to Master TOC

Return to Master TOC

Return to Section TOC      Return to Section TOC      Return to Section TOC  
Return to Master TOC      Return to Master TOC      Return to Master TOC



# TABLE OF CONTENTS - THEORY OF OPERATION SECTION -

<b>Theory of Operation</b> .....	<b>Section E</b>
Input Power Circuit .....	E-2
Input Line Voltage .....	E-2
Main Transformer .....	E-2
Voltage Selector Switch .....	E-2
Baffle Mounted Diode Bridge .....	E-2
Control Circuits .....	E-3
Output Rectification, Contactor & Control Boards .....	E-3
Optional Circuits .....	E-4
Control Board, Gun Trigger, & Wire Drive Motor .....	E-4
Protective Devices & Circuits .....	E-5
Thermal Overload Protection .....	E-5
Wirefeed Overload Protection .....	E-5

**FIGURE E.1 THEORY OF OPERATION BLOCK DIAGRAM**

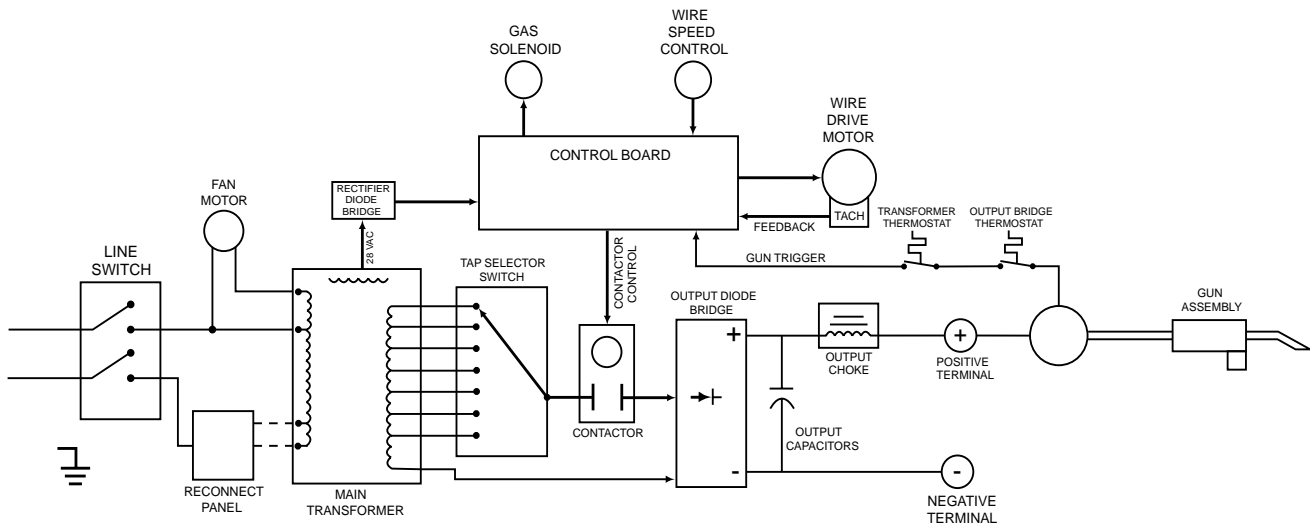
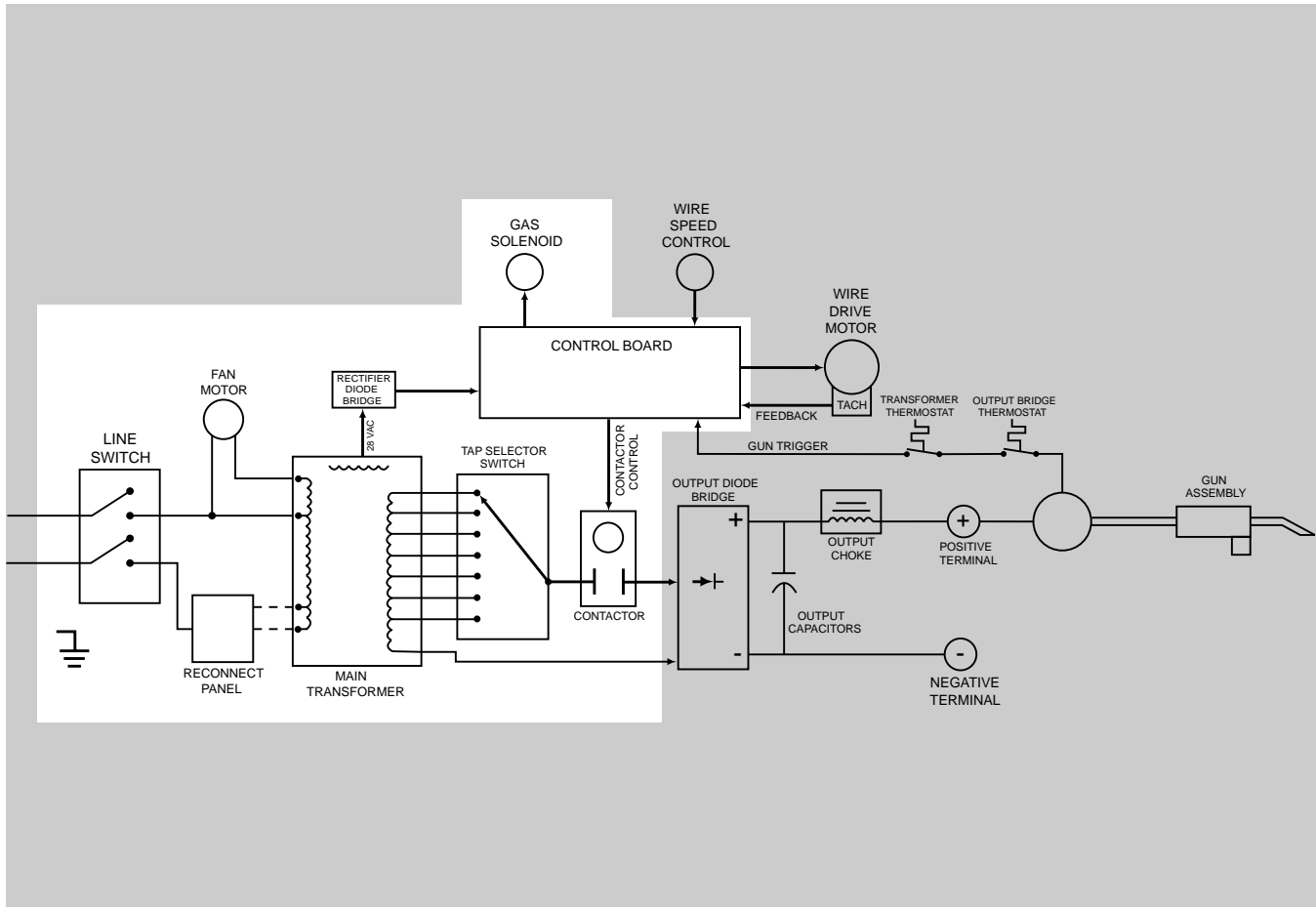

FIGURE E.2 – INPUT POWER CIRCUIT.



## INPUT LINE VOLTAGE, MAIN TRANSFORMER, VOLTAGE SELECTOR SWITCH AND BAFFLE MOUNTED DIODE BRIDGE

The single phase input power is connected to the POWER MIG 200 through a line switch located on the front panel.

A reconnect panel allows the user to configure the machine for the desired input voltage. The AC input voltage is applied to the primary of the main transformer. The cooling fan motor (120VAC) is powered from a portion of the primary winding. For welding purposes, the main transformer converts the high voltage, low current input power to a lower voltage, higher current output. This tapped secondary winding is coupled to a voltage selector switch. By selecting one of seven positions on the switch the user can preset the desired voltage output

from a minimum setting (A) to a maximum voltage setting (G). In addition, the main transformer houses a 28VAC winding. This 28VAC is rectified at the baffle mounted diode bridge and the resultant DC voltage is used to power the electronics on the control board, the output contactor, and the gas solenoid.

**NOTE:** Unshaded areas of block logic diagrams are the subject of discussion.

POWER MIG 200

**LINCOLN**  
ELECTRIC

FIGURE E.3 – CONTROL CIRCUITS.

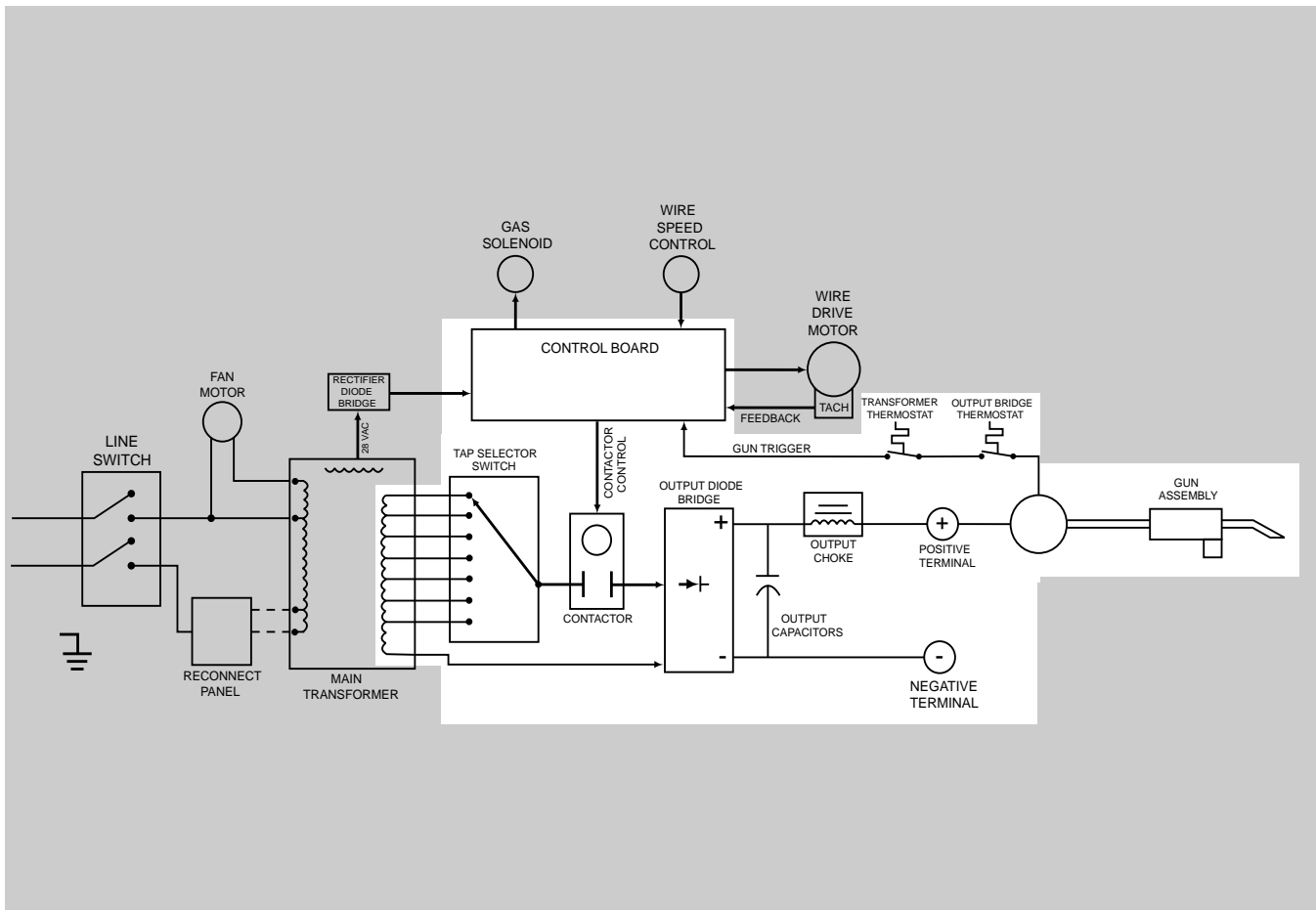

### OUTPUT RECTIFICATION, CONTACTOR AND CONTROL BOARD

The AC voltage developed on the secondary winding is applied, through the selector switch and output contactor, to the output rectifier bridge. This DC welding voltage is filtered by the output capacitors and applied to the output terminals and welding gun. Since the output choke is in series with the positive leg of the output rectifier and also in series with the gun and welding load, a filtered constant voltage output is applied to the output terminals of the machine.

**NOTE:** Unshaded areas of block logic diagrams are the subject of discussion.

POWER MIG 200

**LINCOLN**  
ELECTRIC

FIGURE E.4 – OPTIONAL CIRCUITS.

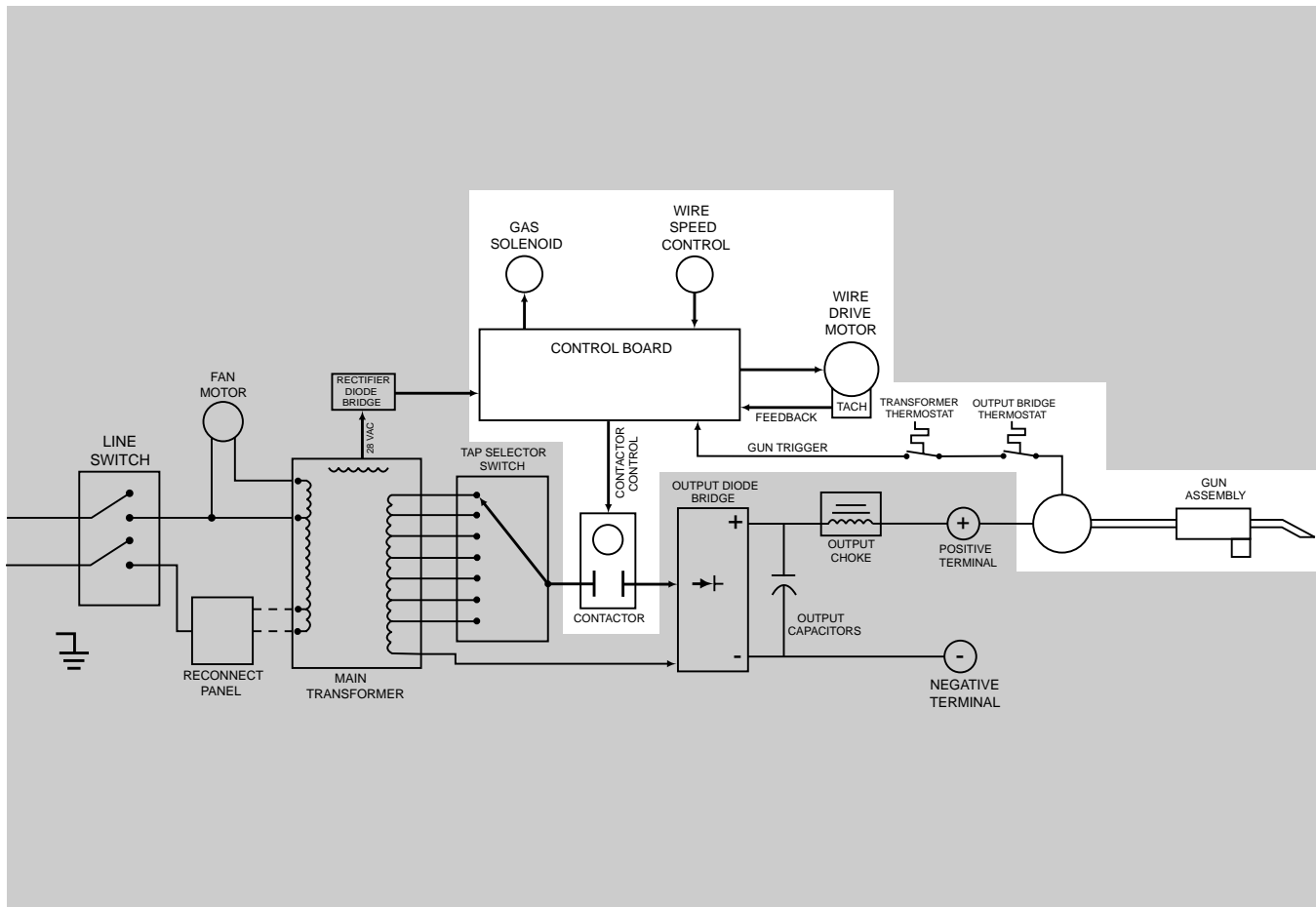

## CONTROL BOARD, GUN TRIGGER AND WIRE DRIVE MOTOR

When the control board receives an activation command from the trigger circuit the control board activates the gas solenoid, output contactor, and the wire drive motor. The control board monitors the motor's tach feedback signals and compares these to the wire speed control setting. The proper armature voltage is then applied to the wire drive motor. The drive motor speed is thus controlled which in turn regulates the electrode wire feed speed through the gun.

Two thermostats are included in the trigger circuitry. If either of these thermostats would "open", the trigger circuit would be interrupted and the machine's output would be disabled.

**NOTE:** Unshaded areas of block logic diagrams are the subject of discussion.

POWER MIG 200

**LINCOLN**  
ELECTRIC



## PROTECTIVE DEVICES AND CIRCUITS

### THERMAL AND OVERLOAD PROTECTION

The POWER MIG 200 has two built-in protective thermostats that respond to excessive temperatures. One is located on the main transformer. The other thermostat is located on the output rectifier heat sink assembly. They open the wire feed and welder output circuits if the machine exceeds the maximum safe operating temperature. This can be caused by a frequent overload or high ambient temperature.

The thermostats are self-resetting once the machine cools sufficiently. If the thermostat shutdown is caused by excessive output or duty cycle and the fan is operating normally, the power switch may be left on and the reset should occur within a 15 minute period. If the fan is not turning or the air intake louver are obstructed, then the input power must be removed and the fan problem or air obstruction must be corrected.

### WIREFEED OVERLOAD PROTECTION

The POWER MIG 200 has solid state overload protection of the wire drive motor. If the motor becomes overloaded, the protection circuitry turns off the wire feed speed and gas solenoid. Check for proper size tip liner, drive rolls, and any obstructions or bends in the gun cable. Check for any other factors that would impede the wire feeding. To resume welding, simply pull the trigger. There is no circuit breaker to reset, as the protection is done with reliable solid state electronics.

Return to Section TOC  
Return to Master TOC  
Return to Section TOC  
Return to Master TOC  
Return to Section TOC  
Return to Master TOC  
Return to Section TOC  
Return to Master TOC

POWER MIG 200



# TABLE OF CONTENTS - TROUBLESHOOTING AND REPAIR SECTION -

<b>Troubleshooting and Repair</b> .....	<b>Section F</b>
How to Use Troubleshooting Guide .....	F-2
PC Board Troubleshooting Procedures .....	F-3
Troubleshooting Guide .....	F-4
Test Procedures .....	F-11
Main Transformer Test .....	F-11
Wire Drive Motor and Tachometer Feedback Test .....	F-15
Output Bridge Rectifier Test .....	F-19
Contactor Test .....	F-21
Voltage Waveforms .....	F-23
Component Replacement Procedures .....	F-27
Control Board Replacement .....	F-27
Wire Drive Motor Assembly Replacement .....	F-29
Output Diode Bridge Rectifier Replacement .....	F-33
Output Capacitors Replacement .....	F-37
Main Transformer Replacement .....	F-41
Fan Blade/Motor Replacement .....	F-47
Output Contactor Replacement .....	F-49
Retest After Repair .....	F-52

## **WARNING**



### **ELECTRIC SHOCK can kill.**

- Never work on the inside of the machine without removing the input power. You can receive a life threatening electrical shock if you fail to do this. Only qualified technicians should perform installation, maintenance, and troubleshooting work on the machine.

---

## How To Use Troubleshooting Guide

---

### WARNING

Service and Repair should only be performed by Lincoln Electric Factory Trained Personnel. Unauthorized repairs performed on this equipment may result in danger to the technician and machine operator and will invalidate your factory warranty. For your safety and to avoid Electrical Shock, please observe all safety notes and precautions detailed throughout this manual.

---

This Troubleshooting Guide is provided to help you locate and repair possible machine malfunctions. Simply follow the three step procedure below.

**Step 1. LOCATE PROBLEM (SYMPTOM).** Look under the column labeled "PROBLEM (SYMPTOMS)". This column describes possible symptoms that the machinery may exhibit. Find the listing that best describes the symptom that the machine is exhibiting. Symptoms are grouped according to: feeding problems and function problems.

**Step 2. PERFORM EXTERNAL TESTS.** The second column labeled "POSSIBLE AREAS OF MISADJUSTMENT(S)" lists the obvious external possibilities that may contribute to the machine symptom. Perform these tests/checks in the order listed. In general, these tests can be conducted without removing the case wrap-around cover.

**Step 3. PERFORM COMPONENT TESTS.** The last column labeled "RECOMMENDED COURSE OF ACTION" lists the most likely components that may have failed in your machine. It also specifies the appropriate test procedure to verify that the subject component is either bad or good. If there are a number of possible components, check the components in the order listed to eliminate one possibility at a time until you locate the cause of your problem.

All the necessary test specifications and repair procedures are described in detail following the troubleshooting guide. All electrical test points, terminal strips, junctions, etc., can be found on the electrical wiring diagrams and schematics in the Electrical Diagram Section.

### CAUTION

If for any reason you do not understand the test procedures or are unable to perform the tests/repairs safely, contact the Lincoln Electric Service Department for technical troubleshooting assistance before you proceed. Call 1-888-935-3877.

---

## PC BOARD TROUBLESHOOTING PROCEDURES

**⚠ WARNING**

**ELECTRIC SHOCK  
can kill.**

• Have an electrician install and service this equipment. Turn the input power OFF at the fuse box before working on equipment. Do not touch electrically hot parts.

**⚠ CAUTION**

Sometimes machine failures appear to be due to PC board failures. These problems can sometimes be traced to poor electrical connections. To avoid problems when troubleshooting and replacing PC boards, please use the following procedure:

1. Determine to the best of your technical ability that the PC board is the most likely component causing the failure symptom.
2. Check for loose connections at the PC board to assure that the PC board is properly connected.
3. If the problem persists, replace the suspect PC board using standard practices to avoid static electrical damage and electrical shock. Read the warning inside the static resistant bag and perform the following procedures:



**ATTENTION  
Static-Sensitive  
Devices  
Handle only at  
Static-Safe  
Workstations**

**PC board can be  
damaged by static  
electricity.**

- Remove your body's static charge before opening the static-shielding bag. Wear an anti-static wrist strap. For safety, use a 1 Meg ohm resistive cord connected to a grounded part of the equipment frame.

- If you don't have a wrist strap, touch an unpainted, grounded, part of the equipment frame. Keep touching the frame to prevent static build-up. Be sure not to touch any electrically live parts at the same time.

- Tools which come in contact with the PC board must be either conductive, anti-static or static-dissipative.

- Remove the PC board from the static-shielding bag and place it directly into the equipment. Don't set the PC board on or near paper, plastic or cloth which could have a static charge. If the PC board can't be installed immediately, put it back in the static-shielding bag.

- If the PC board uses protective shorting jumpers, don't remove them until installation is complete.

- If you return a PC board to The Lincoln Electric Company for credit, it must be in the static-shielding bag. This will prevent further damage and allow proper failure analysis.

4. Test the machine to determine if the failure symptom has been corrected by the replacement PC board.

**NOTE:** It is desirable to have a spare (known good) PC board available for PC board troubleshooting.

**NOTE:** Allow the machine to heat up so that all electrical components can reach their operating temperature.

5. Remove the replacement PC board and substitute it with the original PC board to recreate the original problem.
  - a. If the original problem does not reappear by substituting the original board, then the PC board was not the problem. Continue to look for bad connections in the control wiring harness, junction blocks, and terminal strips.
  - b. If the original problem is recreated by the substitution of the original board, then the PC board was the problem. Reinstall the replacement PC board and test the machine.

6. Always indicate that this procedure was followed when warranty reports are to be submitted.

**NOTE:** Following this procedure and writing on the warranty report, "INSTALLED AND SWITCHED PC BOARDS TO VERIFY PROBLEM," will help avoid denial of legitimate PC board warranty claims.

**Troubleshooting Guide** — See Wiring Diagrams for location of specified components and for troubleshooting of specific circuits.

Observe Safety Guidelines detailed in the beginning of this manual.

PROBLEMS (SYMPTOMS)	POSSIBLE AREAS OF MISADJUSTMENT(S)	RECOMMENDED COURSE OF ACTION
<b>OUTPUT PROBLEMS</b>		
Major physical or electrical damage is evident.	1. Contact your local Lincoln Electric authorized field service facility.	1. Contact Lincoln Electric Service Department 1-888-935-3877.
The machine is dead--no open circuit voltage and no wire feed when the gun trigger is activated. The cooling fan is not running.	<ol style="list-style-type: none"> <li>1. Make certain the input power switch (S1) is in the "ON" position.</li> <li>2. Check the input voltage at the machine. The input voltage must match the rating plate and the reconnect panel.</li> <li>3. Check for blown or missing fuses in the input lines.</li> </ol>	<ol style="list-style-type: none"> <li>1. Check the input power switch (S1). It may be faulty.</li> <li>2. Check for broken or missing wires at the reconnect panel.</li> <li>3. Perform the <b>Main Transformer Test</b>.</li> </ol>
There is no open circuit voltage or wire feed when the gun trigger is activated. The cooling fan is running.	<ol style="list-style-type: none"> <li>1. Make sure the input voltage is correct and matches the nameplate rating and reconnect panel configuration.</li> <li>2. One of the two thermostats may be open due to machine overheating. If the machine operates normally after a cooling off period then check for proper fan operation and ventilation. Make certain the machine's duty cycle is not being exceeded.</li> </ol>	<ol style="list-style-type: none"> <li>1. The baffle mounted rectifier bridge may be faulty. Check and replace if necessary.</li> <li>2. Perform the <b>Main Transformer Test</b>.</li> <li>3. Check the thermostats and associated leads for loose or faulty connections. See the wiring diagram.</li> <li>4. The internal triggering circuit/plugs may be faulty. See the wiring diagram.</li> <li>5. The control board may be faulty.</li> </ol>

### ⚠ CAUTION

If for any reason you do not understand the test procedures or are unable to perform the tests/repairs safely, contact the Lincoln Electric Service Department for technical troubleshooting assistance before you proceed. Call 1-888-935-3877.

POWER MIG 200



**Troubleshooting Guide** — See Wiring Diagrams for location of specified components and for troubleshooting of specific circuits.

Observe Safety Guidelines detailed in the beginning of this manual.

PROBLEMS (SYMPTOMS)	POSSIBLE AREAS OF MISADJUSTMENT(S)	RECOMMENDED COURSE OF ACTION
<b>OUTPUT PROBLEMS (Continued)</b>		
(continued from previous page)	<ol style="list-style-type: none"> <li>3. Check the gun trigger leads. Leads #324 to #325 should have continuity (zero ohms) when the gun trigger is activated. If not, the gun trigger or cable may be faulty. Check or replace.</li> <li>4. If a spool gum option kit is installed, check to make sure it is set to the "normal" position if using the POWER MIG 200 built in wire feeder.</li> </ol>	
<p>When the gun trigger is activated and the wire feeds normally, but there is no open circuit voltage.</p>	<ol style="list-style-type: none"> <li>1. Make sure the gun cable and work cables are connected properly and in good condition.</li> <li>2. Make sure the output selector switch is in a good condition position and not between positions.</li> </ol>	<ol style="list-style-type: none"> <li>1. Check the output selector switch for proper operation and good connections.</li> <li>2. Perform the <b>Output Contactor Test</b>.</li> <li>3. Perform the <b>Output Bridge Rectifier Test</b>.</li> <li>4. Perform the <b>Main Transformer Test</b>.</li> <li>5. Check the heavy current carrying leads between the output selector switch, output contactor, output bridge rectifier, and the output terminals for loose or faulty connections. See Wiring Diagram.</li> </ol>

**⚠ CAUTION**

If for any reason you do not understand the test procedures or are unable to perform the tests/repairs safely, contact the Lincoln Electric Service Department for technical troubleshooting assistance before you proceed. Call 1-888-935-3877.

POWER MIG 200



Return to Section TOC

Return to Section TOC

Return to Section TOC

Return to Section TOC

Return to Master TOC

Return to Master TOC

Return to Master TOC

Return to Master TOC

**Troubleshooting Guide** — See Wiring Diagrams for location of specified components and for troubleshooting of specific circuits.

Observe Safety Guidelines detailed in the beginning of this manual.

PROBLEMS (SYMPTOMS)	POSSIBLE AREAS OF MISADJUSTMENT(S)	RECOMMENDED COURSE OF ACTION
<b>OUTPUT PROBLEMS (Continued)</b>		
Output voltage and wire feed speed is present when the gun trigger is NOT activated.	<ol style="list-style-type: none"> <li>1. Remove the gun assembly. If the problem is resolved, the gun assembly is faulty. Repair or replace. If the problem is NOT resolved, the fault is within the POWER MIG 200 machine.</li> </ol>	<ol style="list-style-type: none"> <li>1. Check for “shorts” in the trigger circuitry within the POWER MIG 200 machine. See the wiring diagram.</li> <li>2. The control board may be faulty.</li> </ol>
The machines output is low. Welds are “cold”. The weld beads are rounded or “humped” demonstrating poor wetting into the plate. The machine cannot obtain full rated output of 200 amps at 22VDC.	<ol style="list-style-type: none"> <li>1. Check the input voltage. Make sure the machine is configured properly for the input voltage being applied.</li> <li>2. Make sure the settings for wire feed speed and voltage are correct for the process being used.</li> <li>3. Make sure the electrode polarity is correct for the process being used.</li> <li>4. Check the welding cables and gun for loose or faulty connections.</li> </ol>	<ol style="list-style-type: none"> <li>1. Check for loose or faulty connections on the heavy current carrying leads inside the POWER MIG 200. See the Wiring Diagram.</li> <li>2. The output capacitors may be faulty. Check for loose connections at the capacitors. Also check for leaky capacitors. Replace if necessary.</li> </ol> <p><b>WARNING: The liquid electrolyte in these capacitors is toxic. Avoid contact with any portion of your body.</b></p> <ol style="list-style-type: none"> <li>3. The output selector switch may be faulty. Check for good contact and continuity (zero ohms) through the switch. See the Wiring Diagram.</li> <li>4. Perform the <b>Output Contactor Test</b>.</li> <li>5. Perform the <b>Output Bridge Rectifier Test</b>.</li> <li>6. Perform the <b>Main Transformer Test</b>.</li> </ol>
The output voltage is continuous when the gun trigger is NOT activated. The wire feed functions normally.	<ol style="list-style-type: none"> <li>1. The output contactor may be stuck closed.</li> </ol>	<ol style="list-style-type: none"> <li>1. Perform the <b>Output Contactor Test</b>.</li> </ol>

**⚠ CAUTION**

If for any reason you do not understand the test procedures or are unable to perform the tests/repairs safely, contact the Lincoln Electric Service Department for technical troubleshooting assistance before you proceed. Call 1-888-935-3877.

Return to Section TOC  
Return to Section TOC  
Return to Section TOC  
Return to Section TOC  
Return to Section TOC  
Return to Master TOC  
Return to Master TOC  
Return to Master TOC



**Troubleshooting Guide** – See Wiring Diagrams for location of specified components and for troubleshooting of specific circuits.

Observe Safety Guidelines detailed in the beginning of this manual.

PROBLEMS (SYMPTOMS)	POSSIBLE AREAS OF MISADJUSTMENT(S)	RECOMMENDED COURSE OF ACTION
<b>FUNCTION PROBLEMS</b>		
<p>There is no gas flow when the gun trigger is activated . The wire feeds and the arc voltage is present.</p>	<ol style="list-style-type: none"> <li>1. If a spool gun adapter is installed, make certain the toggle switch in the spool gun kit in the correct position.</li> <li>2. If a spool gun adapter is NOT installed, make certain the jumper plug is installed in J5. See the wiring diagram.</li> <li>3. Check the gas source and hoses for kinks or leaks.</li> </ol>	<ol style="list-style-type: none"> <li>1. Check plug J1 on the control board for loose or faulty connections. See wiring diagram.</li> <li>2. Check the gas solenoid by disconnecting it from leads #108A and #116A&amp;B. Apply a 12VDC external supply to the solenoid. If the solenoid does NOT activate then it may be faulty. Replace.</li> </ol>
<p>The machine stops feeding wire while welding. When the gun trigger is released and pulled again, the wire feed starts.</p>	<ol style="list-style-type: none"> <li>1. Check for a mechanical restriction in the wire feed path. The gun may be clogged.</li> <li>2. Make sure the drive rolls and guide plates are clean and are the correct size.</li> <li>3. Check the spindle for ease of rotation.</li> </ol>	<ol style="list-style-type: none"> <li>1. Check the motor armature current. Normal armature current is 2.0 to 2.7 amps maximum. If the motor armature current is normal, and the motor continues to shut-off, the control board may be faulty. Replace.</li> <li>2. If the motor armature current is high (over 2.7 amps) and there are NO restrictions in the wire feeding path then the motor or gearbox may be defective. Replace.</li> </ol>

**⚠ CAUTION**

If for any reason you do not understand the test procedures or are unable to perform the tests/repairs safely, contact the **Lincoln Electric Service Department** for technical troubleshooting assistance before you proceed. Call 1-888-935-3877

**Troubleshooting Guide** — See Wiring Diagrams for location of specified components and for troubleshooting of specific circuits.

Observe Safety Guidelines detailed in the beginning of this manual.

PROBLEMS (SYMPTOMS)	POSSIBLE AREAS OF MISADJUSTMENT(S)	RECOMMENDED COURSE OF ACTION
<b>WIRE FEEDING PROBLEMS</b>		
Rough wire feeding or the wire will not feed but the drive rolls are turning.	<ol style="list-style-type: none"> <li>1. The gun cable may be kinked or twisted.</li> <li>2. Check the drive roll tension and the position of the grooves.</li> <li>3. Electrode may be rusted or dirty.</li> <li>4. The contact tip may be damaged or not the correct size.</li> <li>5. Check the wire spindle for ease of rotation.</li> <li>6. Make certain the gun is pushed all the way into the gun mount and properly seated.</li> </ol>	
No control of wire feed speed. Other machine functions are normal.	<ol style="list-style-type: none"> <li>1. The wire feed speed control may be dirty. Rotate several times and check if the problem is resolved.</li> </ol>	<ol style="list-style-type: none"> <li>1. The wire speed control potentiometer may be faulty. Check or replace. Normal potentiometer resistance is 10K ohms.</li> <li>2. Perform the <b>Wire Drive Motor and Tachometer Feedback Test</b>.</li> <li>3. The control board may be faulty.</li> </ol>
There is no wire feed when the gun trigger is activated. Normal open circuit weld voltage is present and the gas solenoid functions normally.	<ol style="list-style-type: none"> <li>1. Check for adequate wire supply.</li> <li>2. If the drive rolls are turning, check for a mechanical restriction in the wire feed path.</li> <li>3. The gun liner may be clogged. Check or replace.</li> <li>4. If the drive rolls are not turning when the gun trigger is activated, contact your local Lincoln Electric Authorized Field Service Facility.</li> </ol>	<ol style="list-style-type: none"> <li>1. Perform the <b>Wire Drive Motor and Tachometer Feedback Test</b>.</li> <li>2. The wire speed control potentiometer may be faulty. Check or replace. Normal potentiometer resistance is 10K ohms.</li> <li>3. The control board may be faulty.</li> </ol>

### ⚠ CAUTION

If for any reason you do not understand the test procedures or are unable to perform the tests/repairs safely, contact the **Lincoln Electric Service Department** for technical troubleshooting assistance before you proceed. Call 1-888-935-3877

POWER MIG 200



Return to Section TOC

Return to Section TOC

Return to Section TOC

Return to Section TOC

Return to Master TOC

Return to Master TOC

Return to Master TOC

Return to Master TOC

**Troubleshooting Guide** – See Wiring Diagrams for location of specified components and for troubleshooting of specific circuits.

Observe Safety Guidelines detailed in the beginning of this manual.

PROBLEMS (SYMPTOMS)	POSSIBLE AREAS OF MISADJUSTMENT(S)	RECOMMENDED COURSE OF ACTION
<b>WELDING PROBLEMS</b>		
Poor arc striking with electrode sticking or blasting off.	<ol style="list-style-type: none"> <li>1. Make sure the settings for wire feed speed and voltage are correct for the process being used.</li> <li>2. Make certain the gas shielding is correct for the process being used.</li> <li>3. Make sure the machine's reconnect panel is configured properly for the input voltage being applied.</li> </ol>	<ol style="list-style-type: none"> <li>1. The output capacitors may be faulty. Check for loose connections at the capacitors. Also check for leaky capacitors. Replace if necessary.</li> </ol> <p><b>WARNING: The liquid electrolyte in these capacitors is toxic. Avoid contact with any portion of your body.</b></p> <ol style="list-style-type: none"> <li>2. Perform the <i>Output Diode Rectifier Test</i>.</li> </ol>
The arc is unstable and or "hunting"	<ol style="list-style-type: none"> <li>1. Check for a worn or melted contact tip.</li> <li>2. Check for loose or faulty connections on the work and gun cables.</li> <li>3. Make sure the electrode polarity is correct for the welding process being used.</li> <li>4. Check for rusted or dirty electrode wire.</li> <li>5. Make sure the machine's settings and shielding gas are correct for the process being used .</li> </ol>	<ol style="list-style-type: none"> <li>1. Check for loose or faulty connections at the output terminals, choke, output capacitors, output selector switch, output contactor, and all heavy current carrying leads. See the wiring diagram.</li> <li>2. Check the output selector switch for proper operation and good connections.</li> <li>3. The output capacitors may be faulty. Check for loose connections at the capacitors. Also check for leaky capacitors. Replace if necessary.</li> </ol> <p><b>WARNING: The liquid electrolyte in these capacitors is toxic. Avoid contact with any portion of your body.</b></p> <ol style="list-style-type: none"> <li>4. Perform the <i>Output Bridge Rectifier Test</i>.</li> </ol>

**⚠ CAUTION**

If for any reason you do not understand the test procedures or are unable to perform the tests/repairs safely, contact the **Lincoln Electric Service Department** for technical troubleshooting assistance before you proceed. Call 1-888-935-3877



Return to Section TOC  
Return to Section TOC  
Return to Section TOC  
Return to Section TOC  
Return to Section TOC

Return to Master TOC  
Return to Master TOC  
Return to Master TOC  
Return to Master TOC  
Return to Master TOC

**Troubleshooting Guide** – See Wiring Diagrams for location of specified components and for troubleshooting of specific circuits.

Observe Safety Guidelines detailed in the beginning of this manual.

PROBLEMS (SYMPTOMS)	POSSIBLE AREAS OF MISADJUSTMENT(S)	RECOMMENDED COURSE OF ACTION
<b>WELDING PROBLEMS</b>		
The weld bead is narrow or ropy. May have porosity with the electrode stubbing into the plate.	<ol style="list-style-type: none"> <li>1. Make sure the welding procedures and electrode polarity are correct for the process being used.</li> <li>2. Make certain the shielding gas is correct and the flow is proper.</li> <li>3. Make sure the weld joint is not “contaminated”.</li> </ol>	<ol style="list-style-type: none"> <li>1. Perform the Output Bridge Rectifier Test.</li> <li>2. The output capacitors may be faulty. Check for loose connections at the capacitors. Also check for leaky capacitors. Replace if necessary.</li> </ol> <p><b>WARNING: The liquid electrolyte in these capacitors is toxic. Avoid contact with any portion of your body.</b></p>
The contact tip seizes in the gas diffuser.	<ol style="list-style-type: none"> <li>1. The tip is being over heated due to excessive current and/or high duty cycle.</li> <li>2. A light application of high temperature anti-seize lubricant may be applied to the contact tip threads.</li> </ol>	

**⚠ CAUTION**

If for any reason you do not understand the test procedures or are unable to perform the tests/repairs safely, contact the **Lincoln Electric Service Department** for technical troubleshooting assistance before you proceed. Call 1-888-935-3877

**POWER MIG 200**



**MAIN TRANSFORMER TEST****⚠ WARNING**

Service and repair should only be performed by Lincoln Electric factory trained personnel. Unauthorized repairs performed on this equipment may result in danger to the technician or machine operator and will invalidate your factory warranty. For your safety and to avoid electrical shock please observe all safety notes and precautions detailed throughout this manual.

If for any reason you do not understand the test procedures or are unable to perform the test/repairs safely, contact the Lincoln Electric service department for technical troubleshooting assistance before you proceed. Call 1-888-935-3877.

---

**TEST DESCRIPTION**

This test will determine if the correct voltages are being applied.

- a. Applied to the primary windings of the main transformers.
- b. Induced on the secondary and auxiliary windings of the main transformer.

**MATERIALS NEEDED**

3/8" Nutdriver

5/16" Nutdriver

Volt-ohmmeter

This procedure takes approximately 40 minutes to perform.

## MAIN TRANSFORMER TEST (continued)

FIGURE F.1. – OUTPUT SELECTOR SWITCH TERMINALS

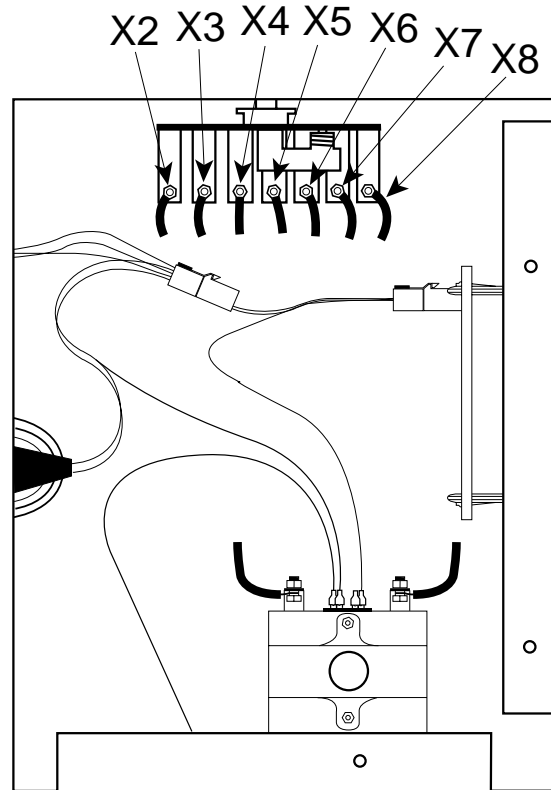

## TEST PROCEDURE

**⚠ WARNING**

THE ON/OFF POWER SWITCH will be “hot” during these tests.

**NOTE:** Secondary voltages will vary proportionately with the primary input voltage.

1. Disconnect the main input power supply to the machine.
2. Remove the case top and side panels with a 3/8” nutdriver.
3. Remove the tool tray with a 5/16” nut driver.
4. Locate leads X2 thru X8 located on the output selector switch. See Figure F.1.
5. Locate lead X1 located on the output rectifier assembly. **See Figure F.2.**

6. Locate leads X9 and X10. **See Figure F.3.**
7. Connect main input power to the machine.
8. Turn the POWER MIG 200 ON/OFF Power Switch to the ON position.

**⚠ WARNING**

**ELECTRIC SHOCK can kill.**

- Do not touch electrically live parts such as output terminals or internal wiring.
- All input power must be electrically disconnected before proceeding.

9. Carefully make the following voltage tests. **See Table F.1.**
10. Turn Off the machine.
11. If any of the voltages are incorrect or missing, check for loose or broken connections between the main transformer and the test points.

POWER MIG 200

**LINCOLN**<sup>®</sup>  
ELECTRIC

**MAIN TRANSFORMER TEST (continued)**

FIGURE F.2. – LEAD X1

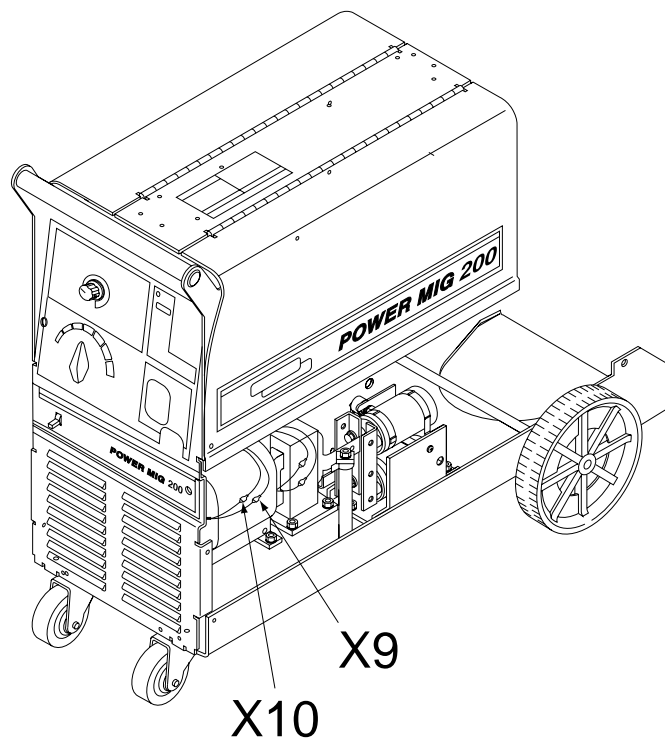
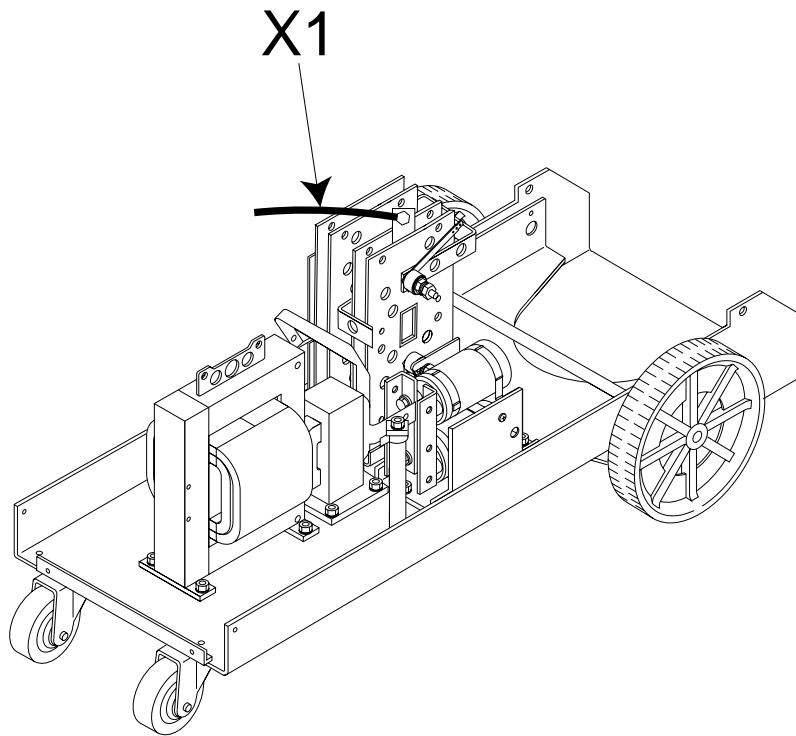

FIGURE F.3. – LEAD X9 & X10

POWER MIG 200



Return to Section TOC  
Return to Master TOC

Return to Section TOC  
Return to Master TOC

Return to Section TOC  
Return to Master TOC

Return to Section TOC  
Return to Master TOC

TABLE F.1. Test Points

INPUT VOLTAGE	TEST POINTS	EXPECTED VOLTAGE READING
230 VAC	X1-X2	11.9-13.0 VAC
230 VAC	X1-X3	14.1-15.2 VAC
230 VAC	X1-X4	16.2-17.5 VAC
230 VAC	X1-X5	18.4-19.7 VAC
230 VAC	X1-X6	20.5-22.0 VAC
230 VAC	X1-X7	22.7-24.2 VAC
230 VAC	X1-X8	24.8-26.5 VAC
230 VAC	X9-X10	26.9-28.8 VAC

12. If ALL the voltages tested are incorrect or missing, test for correct nameplate input voltage between the H1 lead at the ON/OFF POWER SWITCH to H2 or H3 at the reconnect panel. Voltage tested will vary depending on input voltage connection. See wiring diagram for test point locations.
  - A. If the input voltage test is incorrect, check for loose or broken leads between the reconnect panel and the ON/OFF POWER SWITCH.
  - B. Test the ON/OFF POWER SWITCH for proper operation.
13. If the correct nameplate voltage is being applied to the main transformer and one or more of the secondary voltages are missing or are incorrect, the main transformer may be faulty. Replace.
14. When test is complete, replace tool tray, case sides and top.



**WIRE DRIVE MOTOR AND TACHOMETER FEEDBACK TEST****⚠ WARNING**

Service and repair should only be performed by Lincoln Electric factory trained personnel. Unauthorized repairs performed on this equipment may result in danger to the technician or machine operator and will invalidate your factory warranty. For your safety and to avoid electrical shock please observe all safety notes and precautions detailed throughout this manual.

If for any reason you do not understand the test procedures or are unable to perform the test/repairs safely, contact the Lincoln Electric service department for technical troubleshooting assistance before you proceed. Call 1-888-935-3877.

**TEST DESCRIPTION**

This test will determine if the wire drive motor and voltage feedback circuit are functioning properly.

**MATERIALS NEEDED**

5/16" Nutdriver

Volt-Ohmmeter

**This procedure takes approximately 30 minutes to perform.**

## WIRE DRIVE MOTOR AND TACHOMETER FEEDBACK TEST

*(continued)*

FIGURE F.4. – PLUG J4

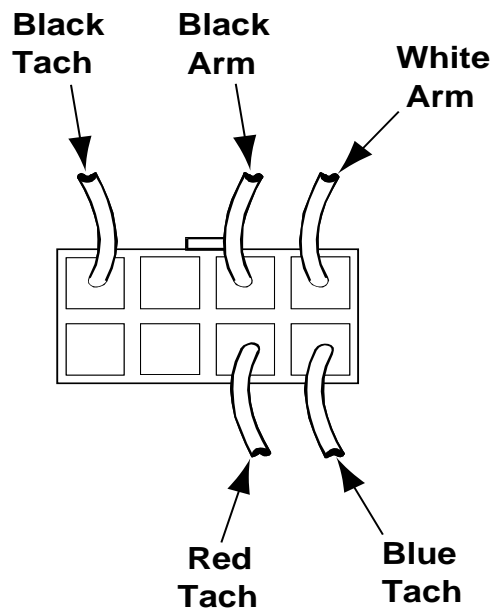
**TEST PROCEDURE**

**NOTE:** POLARITY MUST BE OBSERVED FOR THESE TESTS.

Test for correct wire drive motor armature voltage.

1. Disconnect main input power to the machine.

2. Open the side panels and remove the tool tray using a 5/16" nutdriver.

3. Locate plug J4 on the wiring harness. See Wiring Diagram.

4. Locate the black and white armature leads on plug J4. See Figure F.4.

## WIRE DRIVE MOTOR AND TACHOMETER FEEDBACK TEST (continued)

5. Make the following voltage tests:

### WARNING



#### ELECTRIC SHOCK can kill.

- Do not touch electrically live parts such as output terminals or internal wiring.
- All input power must be electrically disconnected before proceeding.

- Turn the machine OFF between each test.
- Carefully insert the meter probes into the lead side of plug J4. *See Figure F.4.*
- Turn the machine ON and pull the gun trigger to conduct the voltage test.

FROM LEAD	FROM LEAD	FROM LEAD
Black Armature Lead	White Armature Lead	2-29 VDC (varies depending on wire feed speed)

- If the voltage to the wire drive motor armature is zero, check the wires between plug J4 and the wire drive motor. Also check the electrical connector J5 for proper connections and jumper plug. See the Wiring Diagram.
- If all wires and connectors are good and the voltage to the drive motor armature is zero, the control PC board may be faulty. Replace the control PC board.
- If the motor is running at high speed and the armature voltage is high and uncontrollable, Proceed with the tachometer test.

### TEST FOR SUPPLY VOLTAGE TO TACHOMETER

- Disconnect the main AC input power to the machine.

- Locate plug J4.

- Locate the tach leads on plug J4. *See Figure F.5.*

- Connect the main input power to the machine.

- Make the following voltage tests:

### WARNING



#### ELECTRIC SHOCK can kill.

- Do not touch electrically live parts such as output terminals or internal wiring.
- All input power must be electrically disconnected before proceeding.

- Turn the machine OFF between each test.
- Carefully insert the meter probes into the lead side of plug J4.

FROM LEAD	FROM LEAD	FROM LEAD
Black (-)	Red (+)	5-6 VDC

- If the 5-6 VDC is present, check the leads to the tachometer circuit.
- If the leads are okay and 5-6 VDC is present, the correct voltage is being received from the control PC board. Continue with the supply voltage to tachometer test.
- If the 5-6 VDC is not present and the leads are okay, the control PC board may be faulty, replace the control PC board. Also check plug J5 and the jumper plug. See Wiring Diagram.

## WIRE DRIVE MOTOR AND TACHOMETER FEEDBACK TEST

(continued)

### TEST FOR FEEDBACK VOLTAGE TO CONTROL BOARD

1. Disconnect the main AC input power to the machine.
2. Locate plug J4 and the tach leads. See Figure F.5.
3. Connect main input power to the machine.
4. Make the following voltage tests:

#### **⚠ WARNING**



#### **ELECTRIC SHOCK can kill.**

- Do not touch electrically live parts such as output terminals or internal wiring.
- All input power must be electrically disconnected before proceeding.

- a. Turn the machine OFF between each test.
- b. Carefully insert the meter probes into the lead side of plug J4. See Figure F5.

- c. Turn the machine ON and pull the gun trigger to conduct the voltage test.

FROM LEAD	TO LEAD	EXPECTED VOLTAGE
Black (-)	BLUE (+)	3.0 TO 4.0 VDC

5. If the 3.0 to 4.0 VDC is present, the tachometer circuit is sending the correct feedback signal to the control PC board. Check the leads and plug J5. See the Wiring Diagram.
6. If the 3.0 to 4.0 VDC is NOT present or NOT correct, the control PC board is not receiving the proper feedback voltage from the tachometer circuit.
7. If the leads are okay, the tachometer circuit may be faulty, replace the tachometer circuit.
8. Replace the tool tray.

FIGURE F.5. – PLUG J4

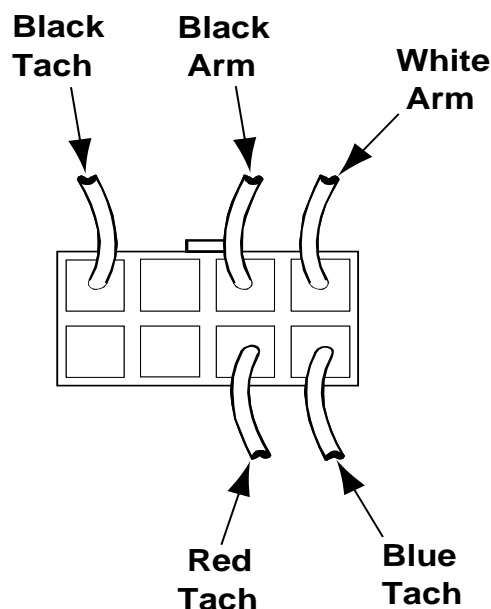

POWER MIG 200

**LINCOLN**  
ELECTRIC

## OUTPUT BRIDGE RECTIFIER TEST

**⚠ WARNING**

Service and repair should only be performed by Lincoln Electric factory trained personnel. Unauthorized repairs performed on this equipment may result in danger to the technician or machine operator and will invalidate your factory warranty. For your safety and to avoid electrical shock please observe all safety notes and precautions detailed throughout this manual.

If for any reason you do not understand the test procedures or are unable to perform the test/repairs safely, contact the Lincoln Electric service department for technical troubleshooting assistance before you proceed. Call 1-888-935-3877.

**TEST DESCRIPTION**

This test will determine if a diode is “shorted” or “leaky”. See the machine waveform section in this manual for normal and abnormal output wave forms.

**MATERIALS NEEDED**

Analog Volt-ohmmeter or Diode Tester

3/8” Nutdriver

1/2” Nutdriver

This procedure takes approximately 20 minutes to perform.

## OUTPUT BRIDGE RECTIFIER TEST *(continued)*

### TEST PROCEDURE

1. Remove input power to the POWER MIG 200 machine.
  2. Using the 3/8" nutdriver, remove the left case side.
  3. Locate and disconnect the negative lead from the output rectifier bridge assembly. Be sure there is no electrical contact between the rectifier and the lead. See Figure F.6.
  4. Test for "shorted" or "leaky" diodes by checking from the anodes to the cathodes of the diode heatsink plates. The readings should be high resistance in one polarity and low resistance in the opposite polarity.
  5. If any of the diodes are "leaky" or "shorted" the output rectifier assembly should be replaced.
  6. When the test is complete, replace the negative output lead previously removed.
  7. Replace the left case side.
- NOTE: Do not disassemble the rectifier assembly.

**Figure F.6. Rectifier Test Points**

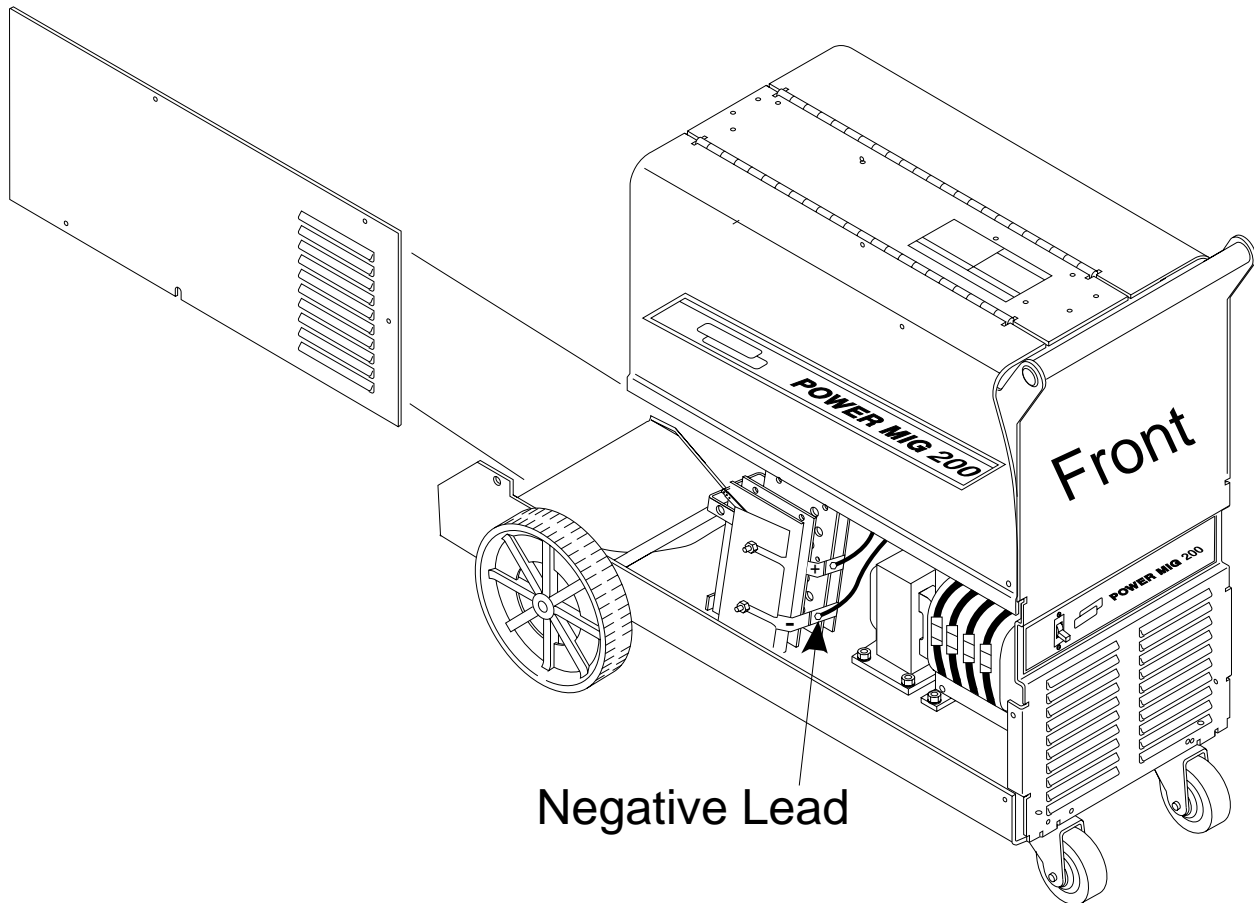

POWER MIG 200



**CONTACTOR TEST****⚠ WARNING**

Service and repair should only be performed by Lincoln Electric factory trained personnel. Unauthorized repairs performed on this equipment may result in danger to the technician or machine operator and will invalidate your factory warranty. For your safety and to avoid electrical shock please observe all safety notes and precautions detailed throughout this manual.

If for any reason you do not understand the test procedures or are unable to perform the test/repairs safely, contact the Lincoln Electric service department for technical troubleshooting assistance before you proceed. Call 1-888-935-3877.

---

**TEST DESCRIPTION**

This test will determine if the contactor is functional.

**MATERIALS NEEDED**

12 VDC Supply

Volt/Ohmmeter

7/16" Wrench

This procedure takes approximately 30 minutes to perform.

## CONTACTOR TEST (Continued)

### TEST PROCEDURE

1. Remove the input power to the POWER MIG 200 machine.
2. Using the 5/16" Nutdriver, remove the tool tray.
3. Locate and remove leads 106B, 106C and 107A from the contactor coil terminals. See Figure F.7. See the Wiring Diagram.
4. Using the 7/16" wrench, remove one lead from the contactors large terminals. See Figure F.7. See the Wiring Diagram.
5. Carefully apply 12 VDC to the contactor coil leads. (small terminals)

### **CAUTION**

Do not leave the 12 VDC applied to the contactor coil for a prolonged period of time (15 seconds maximum). Damage to contactor may result.

6. If the contactor does not activate when the 12VDC is applied, the contactor is faulty. Replace.

7. If the contactor activates when the 12VDC is applied, check the resistance between the two large terminals with the contactor activated. The resistance should be very low (0 to 1 ohm).
8. If the resistance is "high" or "open" between the two large terminals when the contactor is activated, the contactor is faulty. Replace.
9. If the contactor activates and the resistance between the terminals is low when the 12 VDC is applied, the contactor is good

**NOTE:** When the contactor is not activated, the resistance between the terminals should be very high (infinite). If the resistance is always low, the contacts are "stuck" and the contactor is faulty. Replace.

10. When the test is complete, replace leads 106B, 106C and 107A.
11. Replace the lead previously removed from one of the contactor large terminals.
12. Replace the tool tray.

**Figure F.7. Contactor Terminals and Leads**

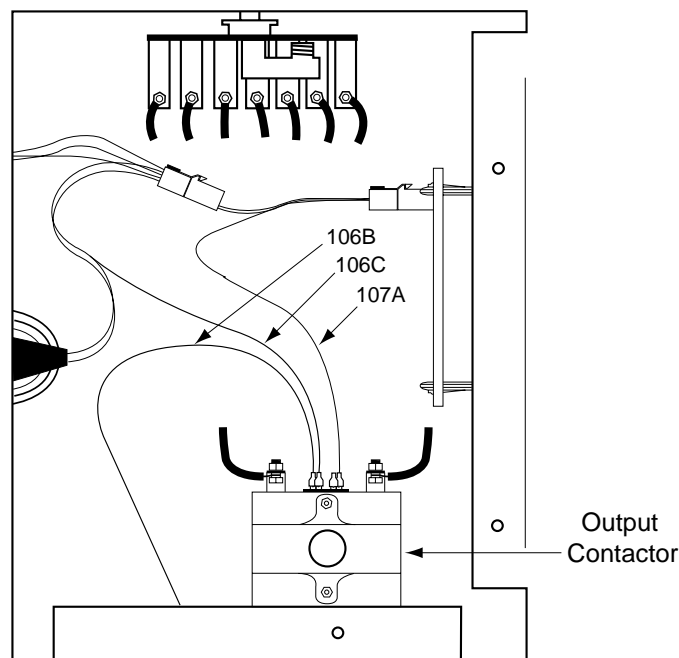

POWER MIG 200

**LINCOLN**  
ELECTRIC



TYPICAL OUTPUT VOLTAGE WAVEFORM - MACHINE LOADED  
(MAX TAP "G")

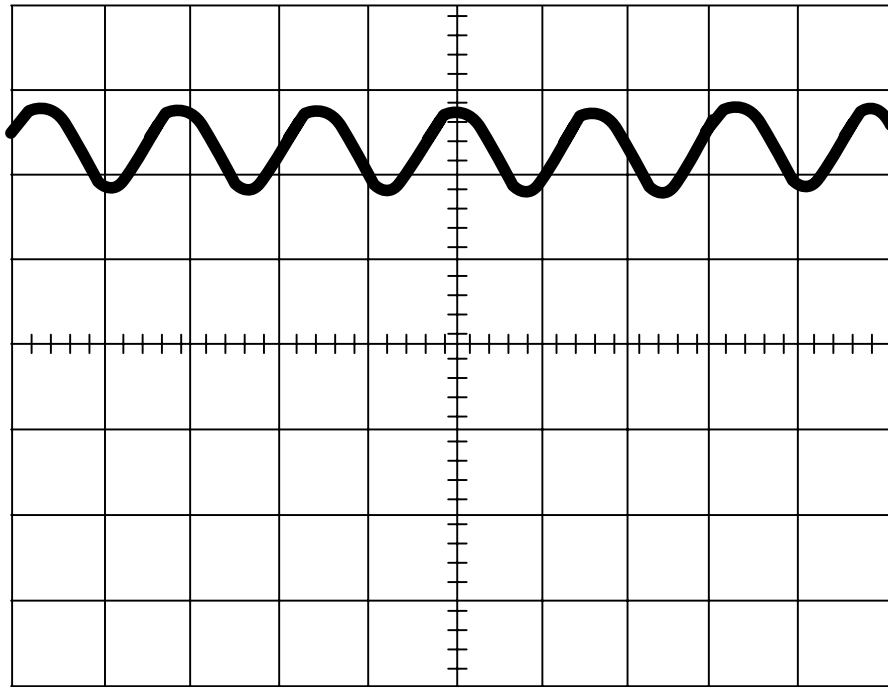

10.0 V

5 ms

0 Volts

MACHINE LOADED TO 200 AMPS AT 22 VDC

SCOPE SETTINGS

<p>This is a typical DC output voltage waveform generated from a properly operating machine. Note that each vertical division represents 10 volts and that each horizontal division represents 5 milliseconds in time. The machine was loaded with a resistance grid bank.</p>	<p>Volts/Div.....10V/Div Horizontal Sweep.....5 ms/Div Coupling.....DC Trigger.....Internal</p>
<p><b>NOTE:</b> Scope probes connected at machine output terminals: (+) probe to electrode, (-) probe to work.</p>	

Return to Section TOC  
Return to Section TOC  
Return to Section TOC  
Return to Section TOC  
Return to Section TOC  
Return to Section TOC

Return to Master TOC  
Return to Master TOC  
Return to Master TOC  
Return to Master TOC  
Return to Master TOC  
Return to Master TOC

NORMAL OPEN CIRCUIT VOLTAGE WAVEFORM (MAX TAP "G")

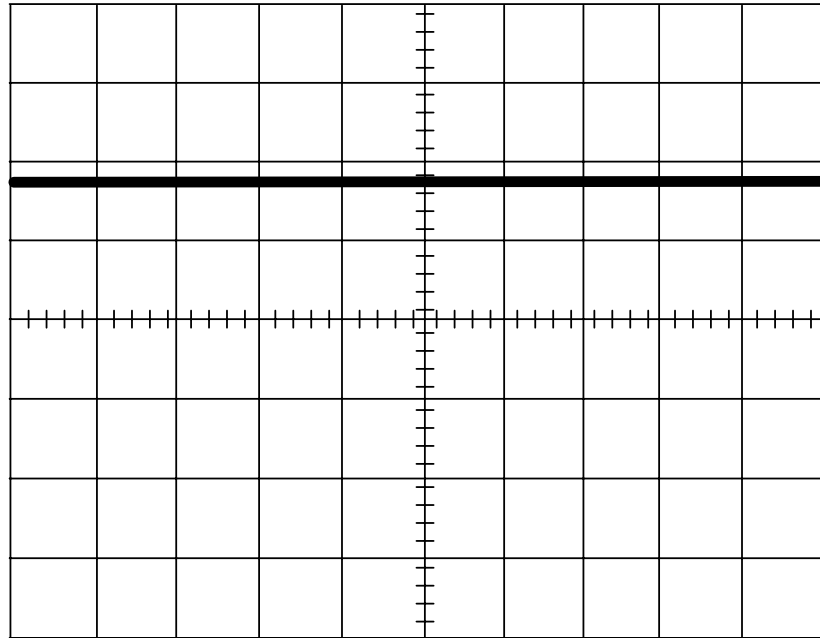

0 Volts

20.0 V

1.0 ms

SCOPE SETTINGS

This is a typical DC output voltage waveform generated from a properly operating machine. Note that each vertical division represents 20 volts and that each horizontal division represents 1.0 milliseconds in time.

**NOTE:** Scope probes connected at machine output terminals: (+) probe to electrode, (-) probe to work.

Volts/Div.....20V/Div  
 Horizontal Sweep.....1.0 ms/Div  
 Coupling.....DC  
 Trigger.....Internal

Return to Section TOC

Return to Section TOC

Return to Section TOC

Return to Section TOC

Return to Master TOC

Return to Master TOC

Return to Master TOC

Return to Master TOC

ABNORMAL OUTPUT VOLTAGE WAVEFORM - MACHINE LOADED (MAX TAP "G") ONE OUTPUT DIODE NOT FUNCTIONING

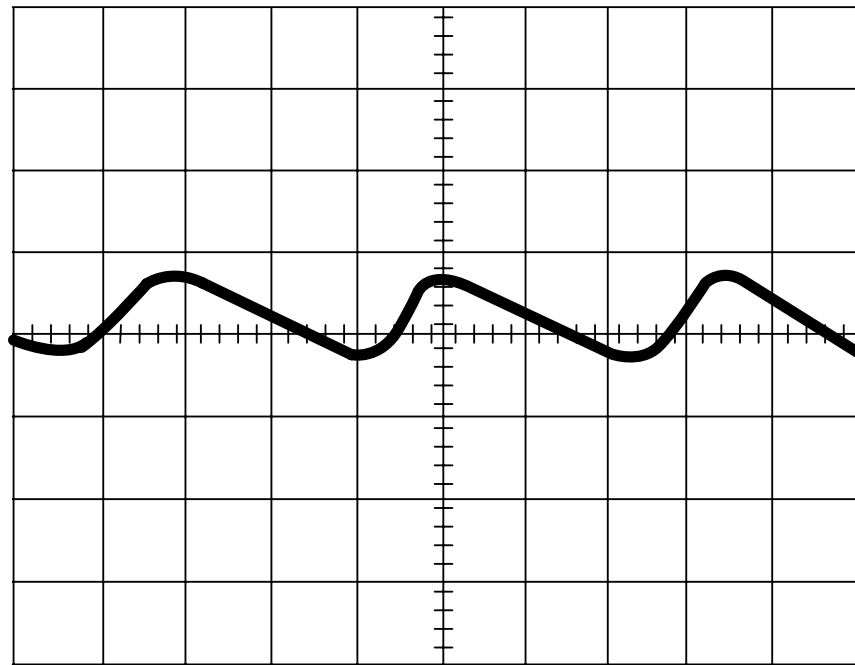

20.0 V

5 ms

0 Volts

MACHINE LOADED TO 180 AMPS AT 16 VDC

SCOPE SETTINGS

This is NOT a typical DC output voltage waveform. One output diode is not functioning. Note the increased ripple content. One diode was disconnected to simulate an open or non-functioning output diode. Each vertical division represents 20 volts and each horizontal division represents 5 milliseconds in time. The machine was loaded with a resistance grid bank.

**NOTE:** Scope probes connected at machine output terminals: (+) probe to electrode, (-) probe to work.

Volts/Div.....20V/Div

Horizontal Sweep.....5 ms/Div

Coupling.....DC

Trigger.....Internal

Return to Section TOC  
Return to Master TOC  
Return to Section TOC  
Return to Master TOC  
Return to Section TOC  
Return to Master TOC  
Return to Section TOC  
Return to Master TOC

ABNORMAL OPEN CIRCUIT VOLTAGE  
OUTPUT CAPACITOR BANK NOT FUNCTIONING (MAX TAP “G”)

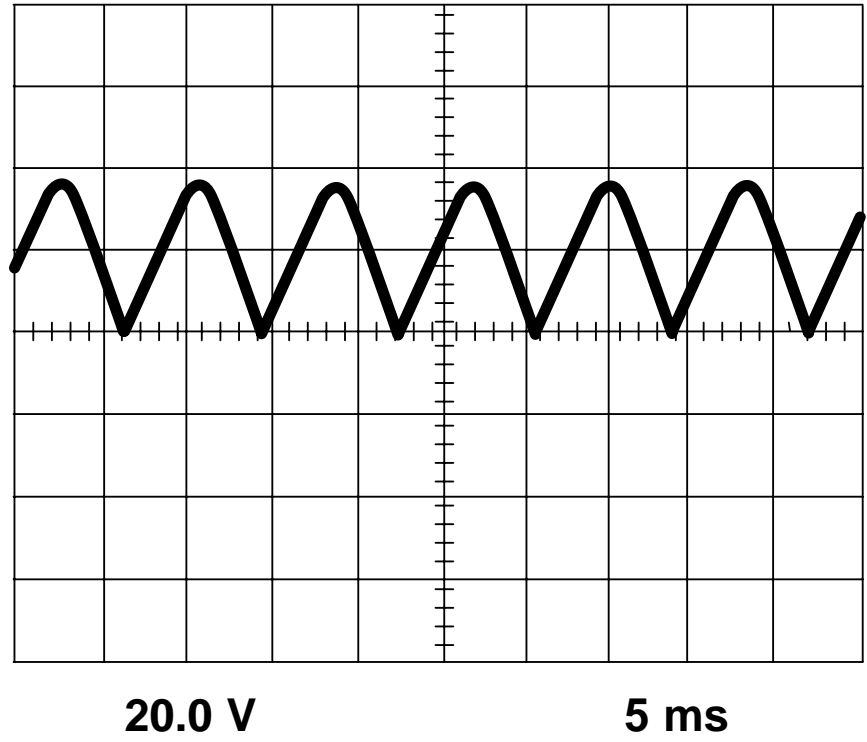

0 Volts

**SCOPE SETTINGS**

<p>This is NOT a typical DC output voltage waveform. The output capacitors are not functioning. Note the lack of “filtering” in the output waveform. The output capacitor bank was disconnected. Each vertical division represents 20 volts and each horizontal division represents 5 milliseconds in time.</p> <p><b>NOTE:</b> Scope probes connected at machine output terminals: (+) probe to electrode, (-) probe to work.</p>	Volts/Div.....20V/Div
	Horizontal Sweep.....5 ms/Div
	Coupling.....DC
	Trigger.....Internal



Return to Section TOC  
 Return to Section TOC  
 Return to Section TOC  
 Return to Master TOC  
 Return to Master TOC  
 Return to Master TOC

**CONTROL BOARD REPLACEMENT****⚠ WARNING**

Service and repair should only be performed by Lincoln Electric factory trained personnel. Unauthorized repairs performed on this equipment may result in danger to the technician or machine operator and will invalidate your factory warranty. For your safety and to avoid electrical shock please observe all safety notes and precautions detailed throughout this manual.

If for any reason you do not understand the test procedures or are unable to perform the test/repairs safely, contact the Lincoln Electric service department for technical troubleshooting assistance before you proceed. Call 1-888-935-3877.

---

**DESCRIPTION**

The following procedure will aid the technician in removing the control board for replacement.

**MATERIALS NEEDED**

5/16" Nutdriver

This procedure takes approximately 20 minutes to perform.

**CONTROL BOARD REPLACEMENT** *(continued)***PROCEDURE**

1. Remove power to the machine.
2. Using a 5/16" nutdriver, remove the three screws securing the tool tray.
3. Locate the control board.
4. Disconnect all associated plugs and leads connected to the control board.
5. Depress the retaining pins on the sides of the four nylon mounts to release the control board. See Figure F.8.
6. Carefully remove the control board.
7. Mount the new board to the nylon mounting pins.
8. Reconnect any plugs or leads previously removed.
9. Replace the tool tray previously removed.

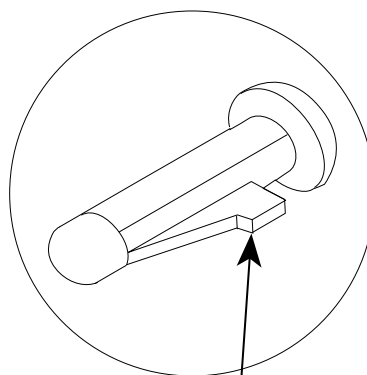
**FIGURE F.8. - CONTROL BOARD MOUNTING PINS**

**DEPRESS  
LOCKING TAB ON  
MOUNTING PIN**

## WIRE DRIVE MOTOR ASSEMBLY REPLACEMENT

### WARNING

Service and repair should only be performed by Lincoln Electric factory trained personnel. Unauthorized repairs performed on this equipment may result in danger to the technician or machine operator and will invalidate your factory warranty. For your safety and to avoid electrical shock please observe all safety notes and precautions detailed throughout this manual.

If for any reason you do not understand the test procedures or are unable to perform the test/repairs safely, contact the Lincoln Electric service department for technical troubleshooting assistance before you proceed. Call 1-888-935-3877.

---

### DESCRIPTION

The following procedure will aid the technician in removing the wire drive and tachometer for repair or replacement.

### MATERIALS NEEDED

5/16" Nutdriver

9/16" Nutdriver

Pliers

Small Flathead Screwdriver

This procedure takes approximately 50 minutes to perform.

## WIRE DRIVE MOTOR ASSEMBLY REPLACEMENT (Continued)

FIGURE F.9. - WIRE DRIVE LOCATION

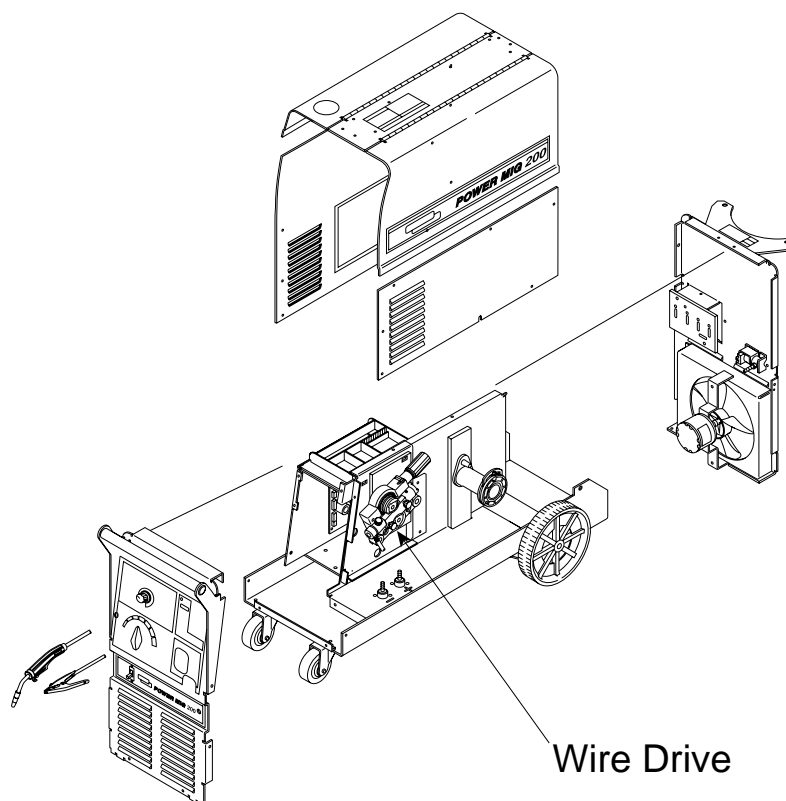

## PROCEDURE

1. Remove power to the machine.
2. Lift cover to gain access to the wire drive. See Figure F.9.
3. Using a pair of pliers, disconnect the gas hose from the bottom of the wire drive. See **Figure F.10**.
4. Using a 9/16" nut driver, remove the thick black positive lead located just above the gas hose. See **Figure F.10**.
5. Using a 5/16" nutdriver, remove the three mounting screws next to the wire drive assembly. See **Figure F.10**.
6. Using a 5/16" nutdriver, remove the two screws on the case front assembly. See **Figure F.11**.
7. Carefully maneuver the wire drive assembly out the side of the machine to gain access to plug J4. See Wiring Diagram.
8. Disconnect plug J4.

NOTE: Disconnect lead from the wire drive motor assembly, not the machine.



WIRE DRIVE MOTOR ASSEMBLY REPLACEMENT (Continued)

FIGURE F.10. - WIRE DRIVE HOSE & LEAD LOCATION

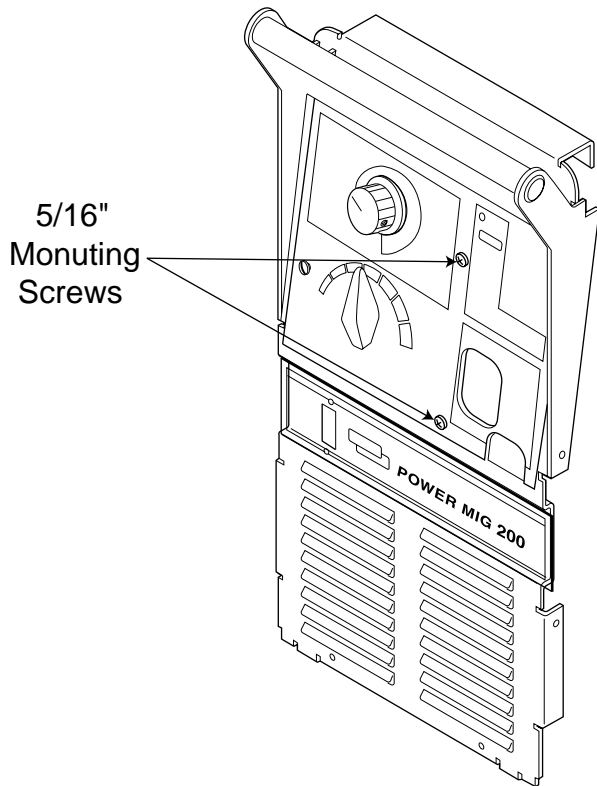
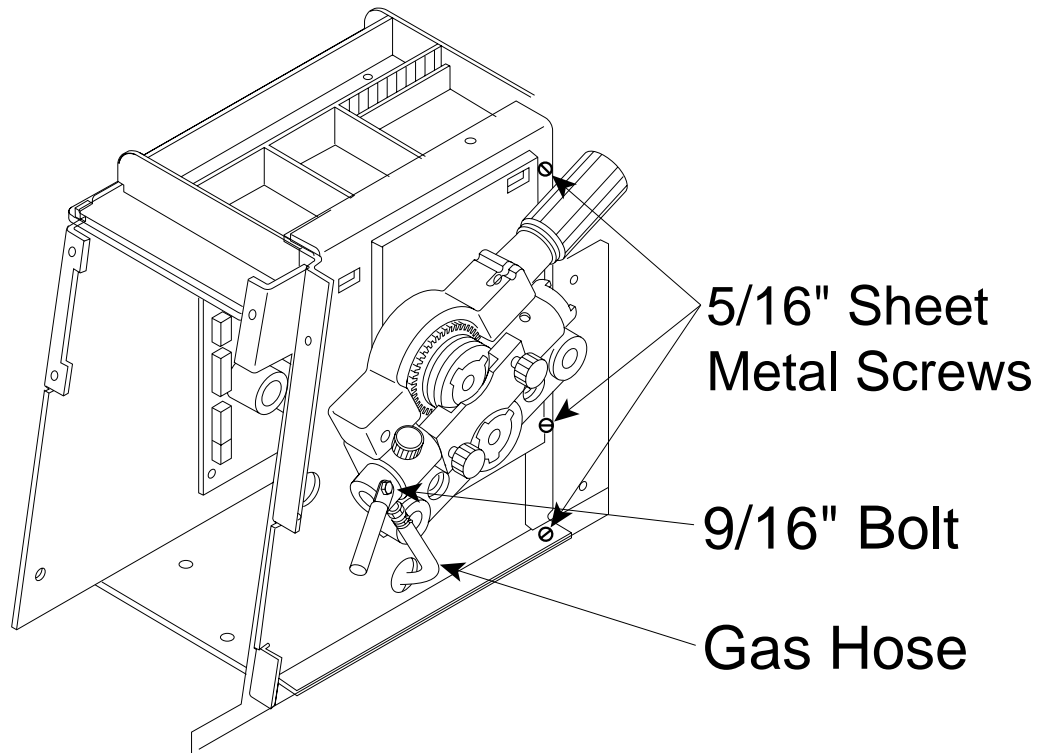

FIGURE F.11. - MOUNTING SCREW LOCATIONS

POWER MIG 200



Return to Section TOC

Return to Section TOC

Return to Section TOC

Return to Section TOC

Return to Master TOC

Return to Master TOC

Return to Master TOC

Return to Master TOC

**WIRE DRIVE MOTOR ASSEMBLY REPLACEMENT** *(Continued)*

1. Place the new wire drive assembly into its proper position.
2. Connect plug J4.
3. Maneuver assembly back into its original position.
4. Replace all mounting screws previously removed.
5. Using a 3/4" nut driver, replace the thick black lead previously removed.
6. Reconnect the gas hose to the wire drive assembly.
7. Close case wrap around cover.

Return to Section TOC

Return to Master TOC

Return to Section TOC

Return to Master TOC

Return to Section TOC

Return to Master TOC

Return to Section TOC

Return to Master TOC

**OUTPUT DIODE BRIDGE RECTIFIER REPLACEMENT****⚠ WARNING**

Service and repair should only be performed by Lincoln Electric factory trained personnel. Unauthorized repairs performed on this equipment may result in danger to the technician or machine operator and will invalidate your factory warranty. For your safety and to avoid electrical shock please observe all safety notes and precautions detailed throughout this manual.

If for any reason you do not understand the test procedures or are unable to perform the test/repairs safely, contact the Lincoln Electric service department for technical troubleshooting assistance before you proceed. Call 1-888-935-3877.

---

**DESCRIPTION**

The following procedure will aid the technician in removing the output diode bridge rectifier for repair or replacement.

**MATERIALS NEEDED**

3/8" Nutdriver

1/2" Nutdriver

5/16" Nutdriver

This procedure takes approximately 50 minutes to perform.

## OUTPUT DIODE BRIDGE RECTIFIER REPLACEMENT (CONTINUED)

### PROCEDURE

1. Using a 3/8" nutdriver, remove the left side of the case wraparound cover.
2. Locate the output diode bridge rectifier. See Figure F.12.
3. Using a 1/2" nutdriver label and remove the four thick black leads connected to the rectifier.  
NOTE: Be sure to label lead terminals also. Take note of washer placement upon removal.
4. Label and remove leads 104A and 104B. See Wiring Diagram.
5. Using a 5/16" nutdriver locate and remove the four bolts mounting the rectifier bracket to the bottom of the machine. These bolts can be accessed easily from the bottom of the machine. **See Figure F.13.**
6. Carefully manipulate the output diode bridge rectifier and the mounting bracket out of the left side of the machine.
7. Using a 1/2" nutdriver remove the three bolts mounting the bracket to the rectifier. The rectifier is now ready for repair or replacement. **See Figure F.13.**
8. Mount the new rectifier to the mounting bracket using the three 1/2" bolts.
9. Carefully manipulate the rectifier and mounting bracket as a one back into the machine to its proper location.
10. Mount the unit to the bottom of the machine using the four 5/16" mounting bolts previously removed.
11. Reconnect leads 104A and 104B previously removed.
12. Reconnect the four thick black leads previously labeled and removed using a 1/2" nutdriver.
13. Replace the left side of the case wraparound cover.

FIGURE F.12. - OUTPUT DIODE BRIDGE RECTIFIER LOCATION

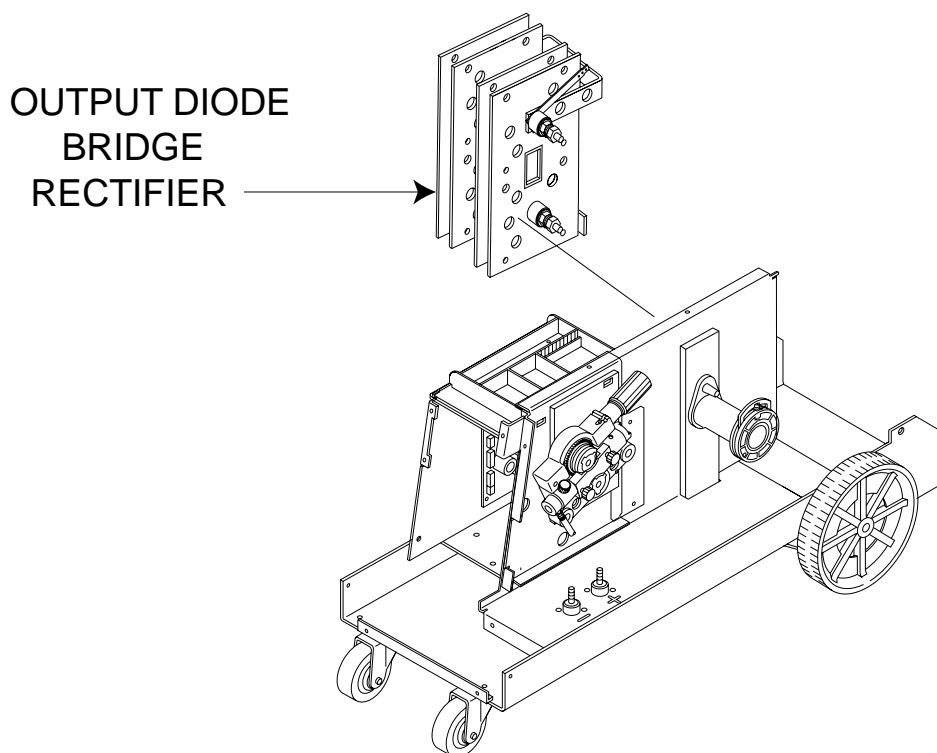

POWER MIG 200

**LINCOLN**  
ELECTRIC

**OUTPUT DIODE BRIDGE RECTIFIER REPLACEMENT (CONTINUED)**

FIGURE F.13. - OUTPUT DIODE BRIDGE RECTIFIER MOUNTING BRACKET

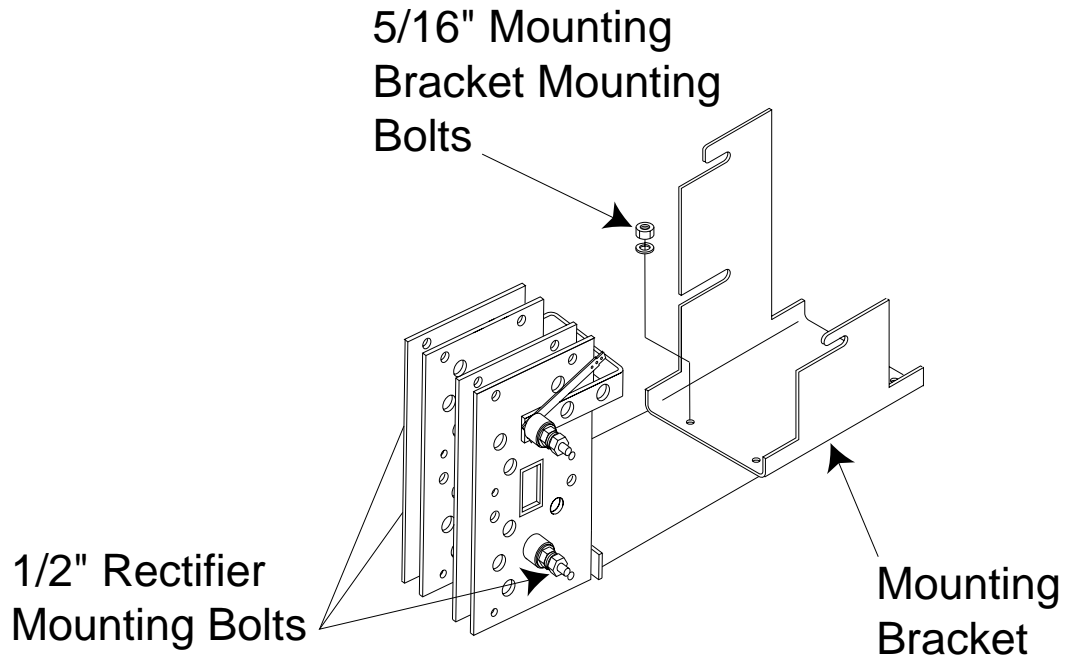

Return to Section TOC  
Return to Master TOC  
Return to Section TOC  
Return to Master TOC  
Return to Section TOC  
Return to Master TOC  
Return to Section TOC  
Return to Master TOC  
Return to Section TOC  
Return to Master TOC

POWER MIG 200



**OUTPUT CAPACITORS REPLACEMENT****⚠ WARNING**

Service and repair should only be performed by Lincoln Electric factory trained personnel. Unauthorized repairs performed on this equipment may result in danger to the technician or machine operator and will invalidate your factory warranty. For your safety and to avoid electrical shock please observe all safety notes and precautions detailed throughout this manual.

If for any reason you do not understand the test procedures or are unable to perform the test/repairs safely, contact the Lincoln Electric service department for technical troubleshooting assistance before you proceed. Call 1-888-935-3877.

---

**DESCRIPTION**

The following procedure will aid the technician in removing the output capacitors for repair or replacement.

**MATERIALS NEEDED**

3/8" Nutdriver

1/2" Wrench

This procedure takes approximately 30 minutes to perform.

## OUTPUT CAPACITORS REPLACEMENT *(Continued)*

### PROCEDURE

1. Using a 3/8" nutdriver, remove the lower right side case wraparound cover. See Figure F.14.
2. Locate capacitor bank. See Figure F.14.
3. Label and remove the five leads connected to the capacitor bank using a 1/2" wrench. Note washer position upon removal. **See Figure F.15.**
4. Using a 3/8" nutdriver, remove the three capacitor bank nuts and lock washers from the three mounting bolts. **See Figure F.15.**
5. Remove the capacitor bank assembly from the machine.
6. Place the new capacitor bank into its proper location inside the machine.
7. Replace the three 3/8" nuts and lock washers previously removed.
8. Using a 1/2" wrench, reconnect the five labeled leads and associated washers previously removed.
9. Replace the lower right side case wraparound cover previously removed.

FIGURE F.14. - CAPACITOR BANK LOCATION

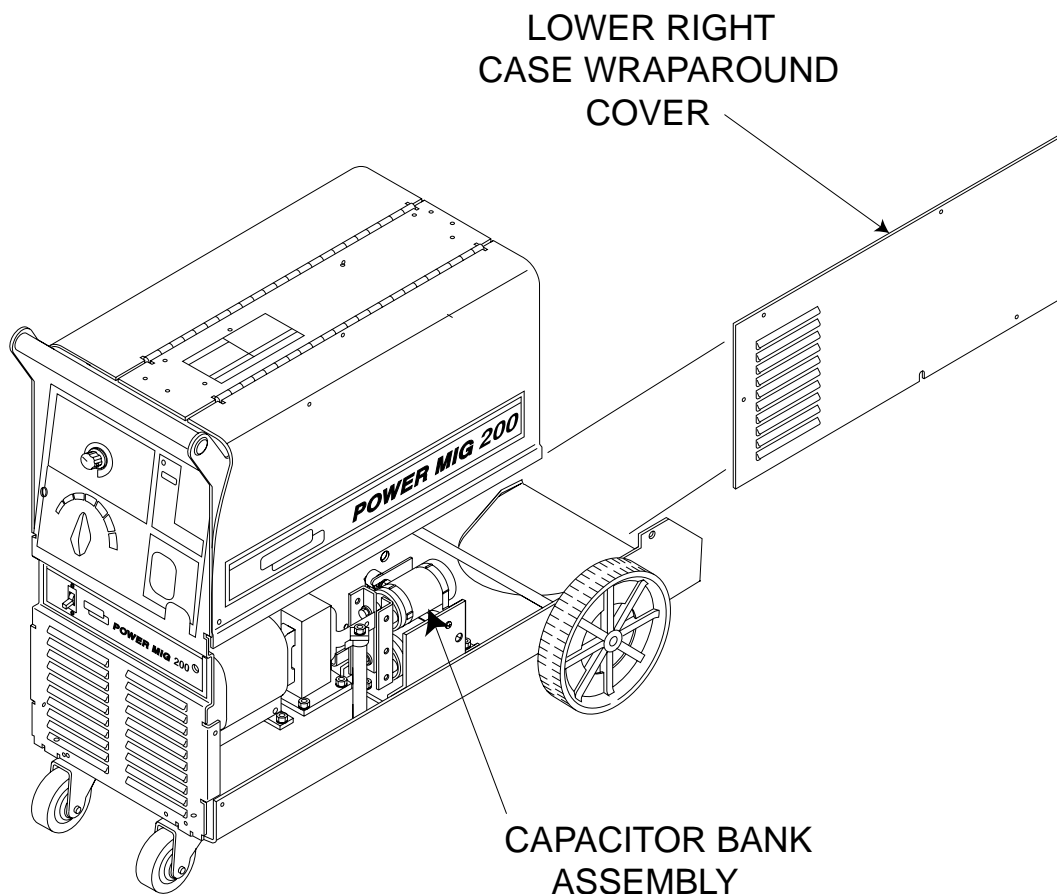

POWER MIG 200





**OUTPUT CAPACITORS REPLACEMENT** *(Continued)*

**FIGURE F.15. - MOUNTING SCREW/BOLT LOCATIONS**

Lead Mounting  
Bolts

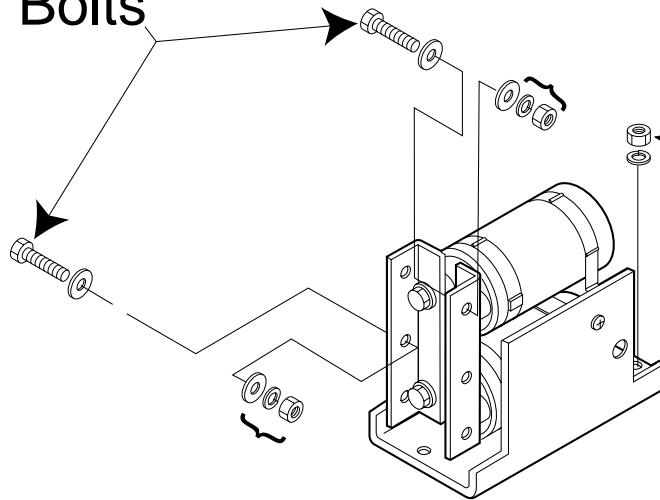

3/8" Nuts &  
Lock washers  
(3 places)

Return to Section TOC  
Return to Section TOC  
Return to Section TOC  
Return to Section TOC  
Return to Master TOC  
Return to Master TOC  
Return to Master TOC  
Return to Master TOC

Return to Section TOC  
Return to Master TOC  
Return to Section TOC  
Return to Master TOC  
Return to Section TOC  
Return to Master TOC  
Return to Section TOC  
Return to Master TOC  
Return to Section TOC  
Return to Master TOC

POWER MIG 200



## MAIN TRANSFORMER REPLACEMENT

**⚠ WARNING**

Service and repair should only be performed by Lincoln Electric factory trained personnel. Unauthorized repairs performed on this equipment may result in danger to the technician or machine operator and will invalidate your factory warranty. For your safety and to avoid electrical shock please observe all safety notes and precautions detailed throughout this manual.

If for any reason you do not understand the test procedures or are unable to perform the test/repairs safely, contact the Lincoln Electric service department for technical troubleshooting assistance before you proceed. Call 1-888-935-3877.

---

**DESCRIPTION**

The following procedure will aid the technician in removing the main transformer for repair or replacement.

**MATERIALS NEEDED**

3/8" Nutdriver

7/16" Nutdriver

1/2" Nutdriver

5/16" Nutdriver

Flathead Screwdriver

This procedure takes approximately 80 minutes to perform.

## MAIN TRANSFORMER REPLACEMENT *(Continued)*

### PROCEDURE

1. Using a 3/8" nutdriver, remove both sides of the case wraparound cover.
2. Using a 5/16" nutdriver, remove the tool tray.
3. Locate the main transformer. See Figure F.16.
4. Label and disconnect leads X9, X10, 104B, & 104C. **See Figure F.17.**
5. Using a flathead screwdriver, Label and disconnect lead H1B and other associated lead connected to the same terminal. These leads are connected to the ON/OFF switch. **See Figure F.17.**
6. Using a 7/16" nutdriver, Label and disconnect leads X8, X7, X6, X5, X4, X3, & X2 from the switch assembly. Note washer position upon removal. **See Figure F.18.**
7. Using a 1/2" nutdriver, label and remove lead X1 from the output diode bridge rectifier.
8. Using a 5/16" Nutdriver, open the rear access panel. **See Figure F.20.**
9. Disconnect lead 118 from the rear access panel. **See Figure F.21.**
10. Feed lead 118 toward the inside of the machine.
11. Cut any necessary cable ties.
12. Remove any necessary wiring harnesses.
13. Disconnect lead 121. **See Figure F.19.**
14. Using a 1/2" nutdriver, remove the four main transformer mounting bolts and associated washers. See Figure F.16.

FIGURE F.16. - MAIN TRANSFORMER LOCATION

## Main Transformer

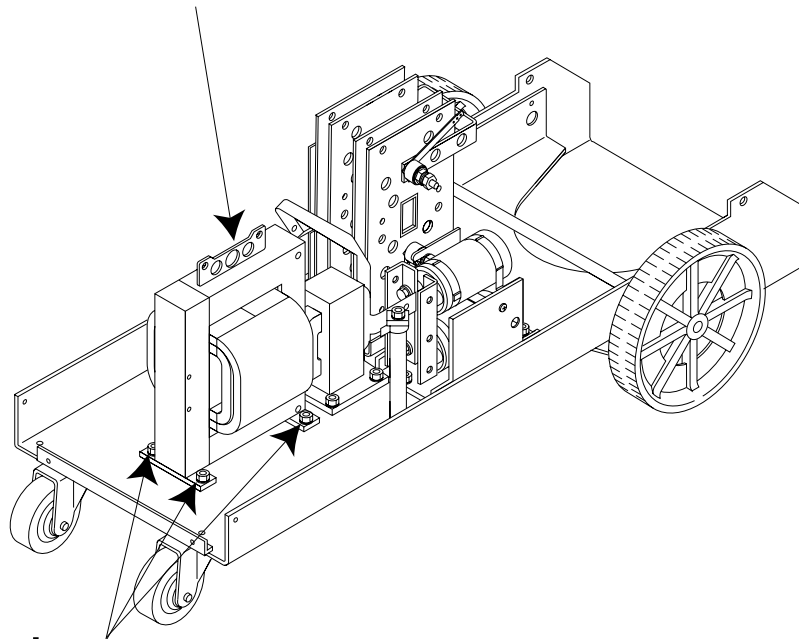

1/2" Mounting  
Bolts

## MAIN TRANSFORMER REPLACEMENT *(Continued)*

15. Carefully maneuver the main transformer out the left side of the machine.

NOTE: Two people may be needed to maneuver the main transformer out of the machine.

### REPLACEMENT

- Carefully maneuver the new main transformer back into the machine and onto its mounting studs.
- Using a 1/2" nutdriver, mount the main transformer in its proper position.
- Reconnect leads 118 and 121 previously removed.
- Using a 5/16" nutdriver, close the rear access panel previously opened.
- Reconnect lead X1 to the output diode bridge rectifier.
- Reconnect leads X8, X7, X6, X5, X4, X3, & X2 previously removed from the switch assembly.
- Reconnect lead H1B and the other associated lead connected to the same terminal. These leads are connected to the ON/OFF switch.
- Replace any necessary cable ties and wiring harnesses.
- Reconnect leads X9, X10, 104B, & 104C. See Wiring Diagram.
- Using a 5/16" nutdriver, replace the tool tray.
- Using a 3/8" nutdriver, replace both sides of the case wraparound cover.

FIGURE F.17. - LEADS X9, X10, 104B, 104C, & H1B

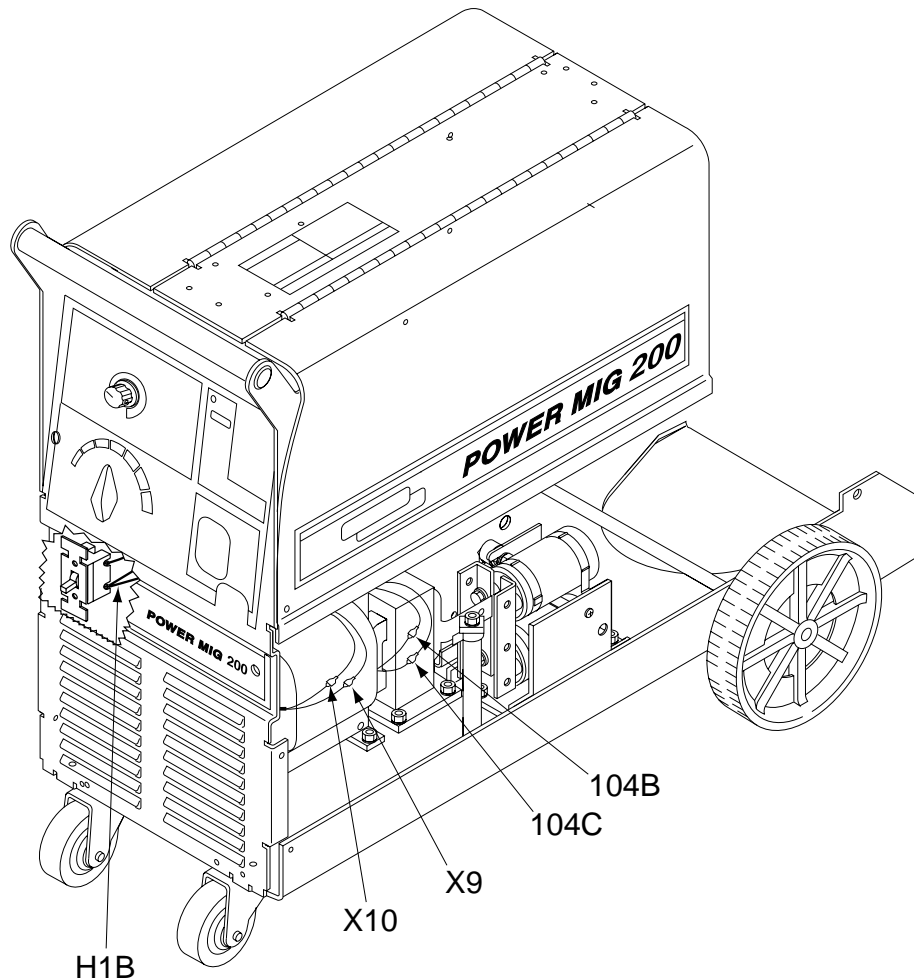

POWER MIG 200



MAIN TRANSFORMER REPLACEMENT (Continued)

FIGURE F.18. - LEADS SWITCH LEADS

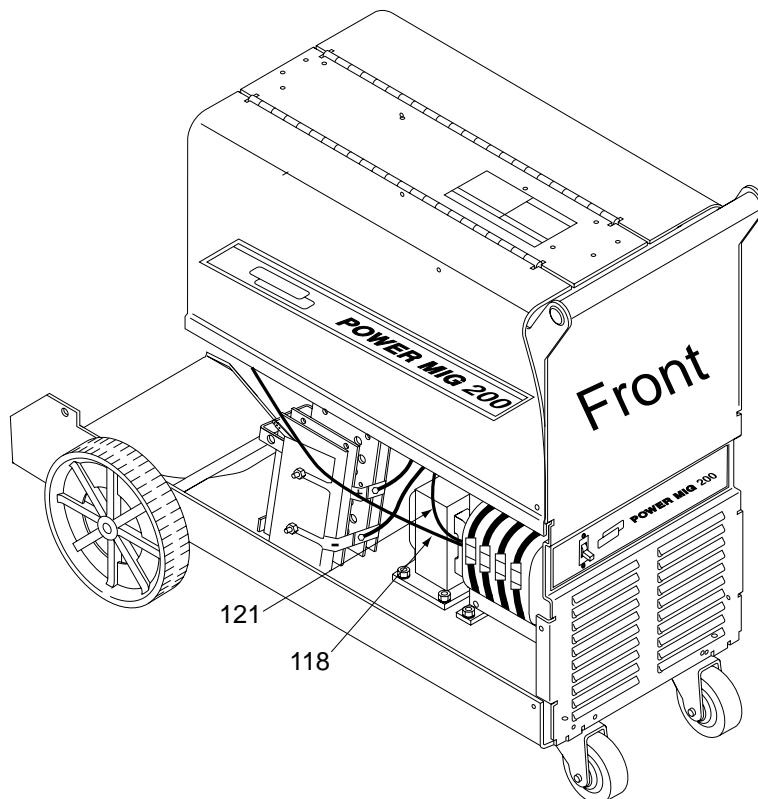
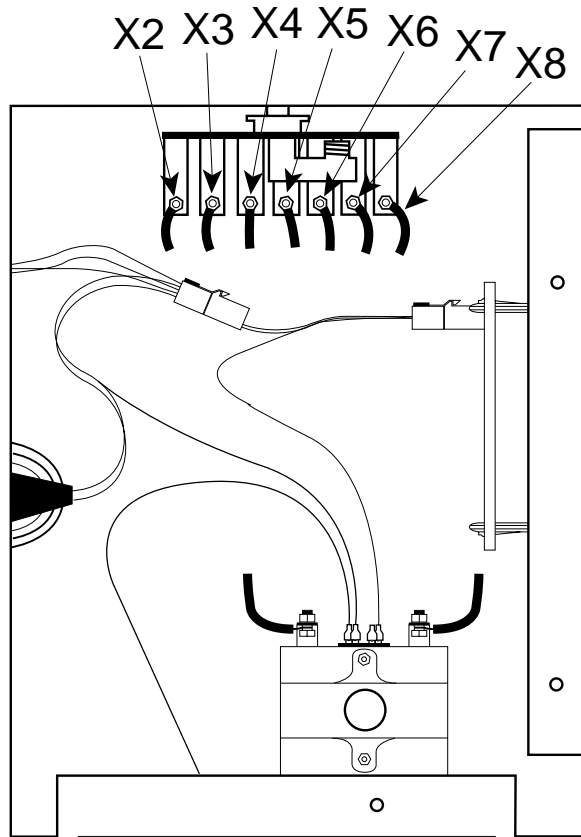

FIGURE F.19. - LEAD 121 & 118

POWER MIG 200



Return to Section TOC

Return to Section TOC

Return to Section TOC

Return to Section TOC

Return to Master TOC

Return to Master TOC

Return to Master TOC

Return to Master TOC

MAIN TRANSFORMER REPLACEMENT (Continued)

FIGURE F.20. - REAR ACCESS PANEL

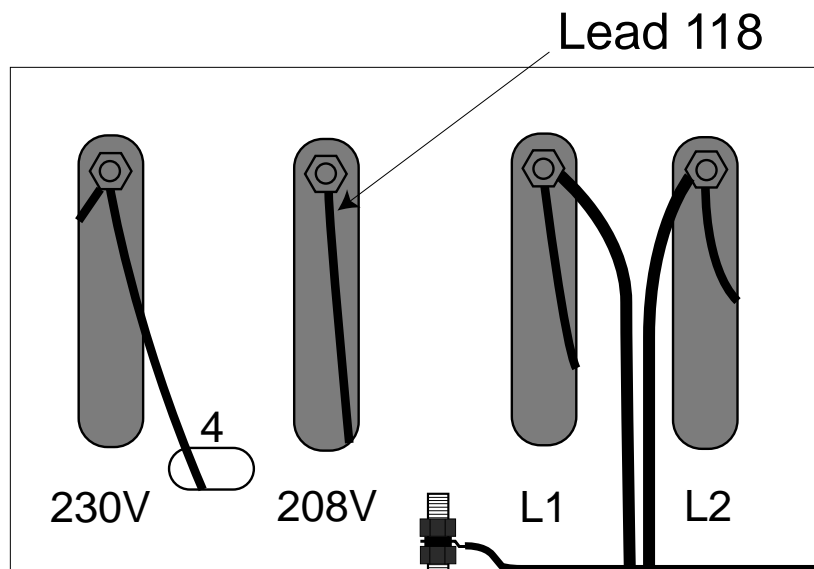
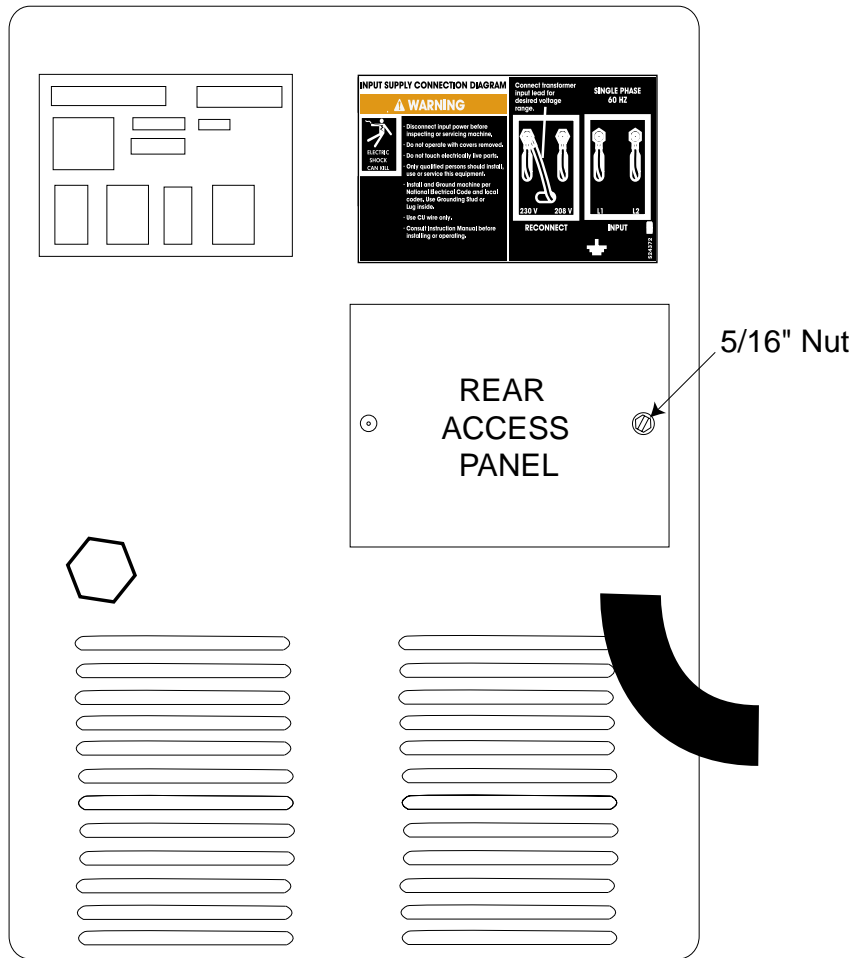

FIGURE F.21. - REAR ACCESS PANEL (CLOSE-UP)

POWER MIG 200



Return to Section TOC

Return to Section TOC

Return to Section TOC

Return to Section TOC

Return to Master TOC

Return to Master TOC

Return to Master TOC

Return to Master TOC

Return to Section TOC  
Return to Master TOC  
Return to Section TOC  
Return to Master TOC  
Return to Section TOC  
Return to Master TOC  
Return to Section TOC  
Return to Master TOC  
Return to Section TOC  
Return to Master TOC

POWER MIG 200





## FAN BLADE/MOTOR REPLACEMENT

**⚠ WARNING**

Service and repair should only be performed by Lincoln Electric factory trained personnel. Unauthorized repairs performed on this equipment may result in danger to the technician or machine operator and will invalidate your factory warranty. For your safety and to avoid electrical shock please observe all safety notes and precautions detailed throughout this manual.

If for any reason you do not understand the test procedures or are unable to perform the test/repairs safely, contact the Lincoln Electric service department for technical troubleshooting assistance before you proceed. Call 1-888-935-3877.

---

**DESCRIPTION**

The following procedure will aid the technician in removing the fan blade and fan motor for repair or replacement.

**MATERIALS NEEDED**

3/8" Nutdriver

5/16" Nutdriver

11/32" Open-End Wrench

Flathead Screwdriver

**This procedure takes approximately 45 minutes to perform.**

## FAN BLADE/MOTOR REPLACEMENT (Continued)

### PROCEDURE

- Using a 3/8" nutdriver, remove the lower right side of the case wraparound cover.
- Perform the **Output Capacitor Bank Removal Procedure**.
- Using a 5/16" nutdriver, remove the four fan mounting screws from the rear of the machine. See Figure F.22.
- Using an open end 11/32" wrench, remove the two fan motor mounting nuts and lockwashers. See Figure F.22.
- Using a flathead screwdriver, loosen the fan blade mounting band. See Figure F.22.
- Pry the fan blade off of the mounting shaft.  
NOTE: If fan blade cracks or breaks upon removal, replace it.
- Carefully manuver the fan motor and fan blade out of the right side of the machine.
- Replace the fan motor and fan blade if necessary.
- Tighten the fan blade mounting band.
- Carefully manuver the fan assembly into its original position.
- Replace the two 11/32" fan motor mounting nuts and lockwashers.
- Replace the four 5/16" fan assembly mounting screws in the rear of the machine.

NOTE: Make sure the fan blade is free to rotate when all of the mounting bolts are replaced.

13. Perform the **Output Capacitor Bank Replacement Procedure**.

14. Replace the lower right case cover.

FIGURE F.22. - FAN MOUNTING BOLTS

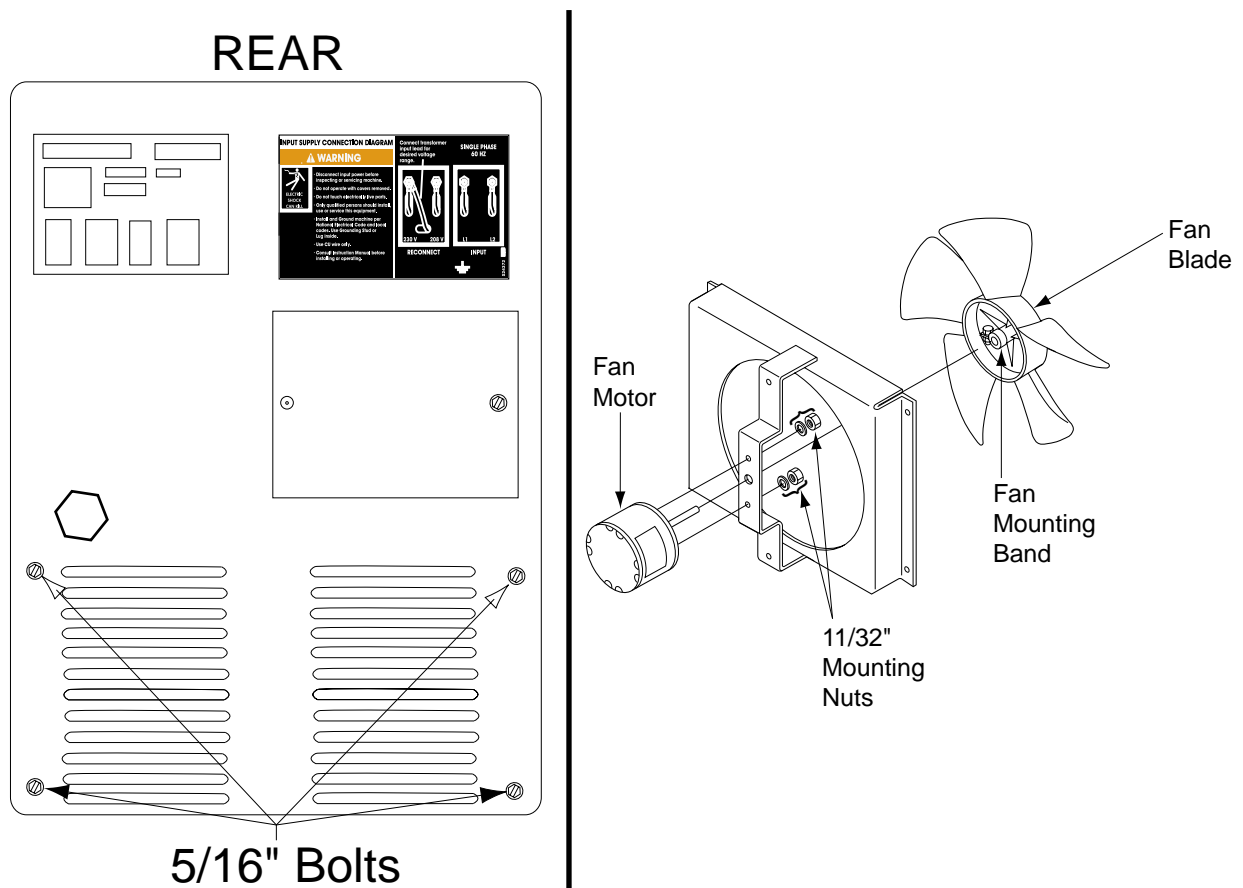

POWER MIG 200

LINCOLN  
ELECTRIC

## OUTPUT CONTACTOR REPLACEMENT

**⚠ WARNING**

Service and repair should only be performed by Lincoln Electric factory trained personnel. Unauthorized repairs performed on this equipment may result in danger to the technician or machine operator and will invalidate your factory warranty. For your safety and to avoid electrical shock please observe all safety notes and precautions detailed throughout this manual.

If for any reason you do not understand the test procedures or are unable to perform the test/repairs safely, contact the Lincoln Electric service department for technical troubleshooting assistance before you proceed. Call 1-888-935-3877.

---

**DESCRIPTION**

The following procedure will aid the technician in removing the output contactor for repair or replacement.

**MATERIALS NEEDED**

7/16" Wrench

5/16" Nutdriver

This procedure takes approximately 40 minutes to perform.

## OUTPUT CONTACTOR REPLACEMENT *(Continued)*

### PROCEDURE

1. Using a 5/16" nutdriver, remove the three screws securing the tool tray.
2. Locate the output contactor. See Figure F.23.
3. Using a 7/16" wrench, label and remove the two thick black leads at the top of the output contactor. Note lead and washer placement for reassembly.
4. Remove lead 107A and note lead placement. See Figure F.23.
5. Remove leads 106B and 106C. See Figure F.23.
6. Using a 7/16" wrench, remove the three mounting bolts from the output contactor. Note washer positions for replacement. See **Figure F.24**.
7. Replace output contactor.
8. Using a 7/16" wrench, mount the new output contactor in its proper location.
9. Reconnect leads 106B, 106C, & 107A to their proper terminals. See Wiring Diagram.
10. Reconnect the two thick black leads previously removed from the top of the output contactor.
11. Replace the tool tray using a 5/16" nutdriver.

FIGURE F.23. - OUTPUT CONTACTOR LEADS

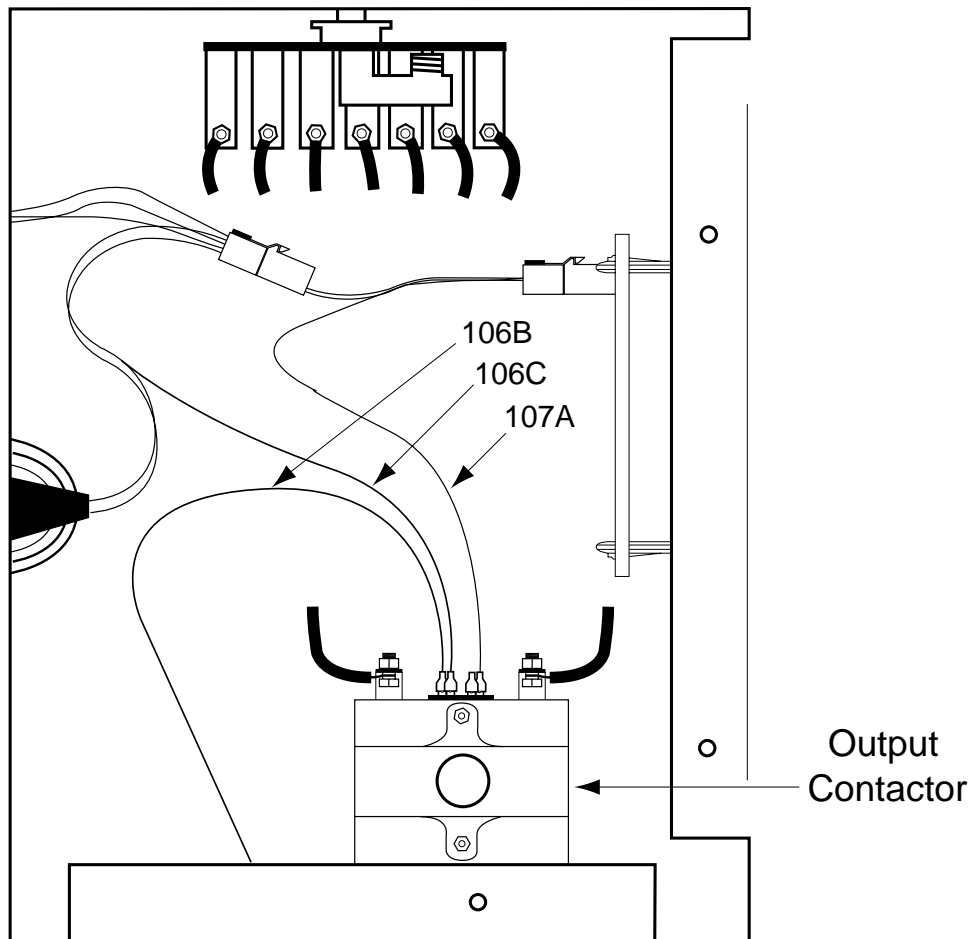

POWER MIG 200

**LINCOLN**<sup>®</sup>  
ELECTRIC

OUTPUT CONTACTOR REPLACEMENT *(Continued)*

FIGURE F.24. - OUTPUT CONTACTOR MOUNTING BOLTS

# 7/16" Mounting Bolts

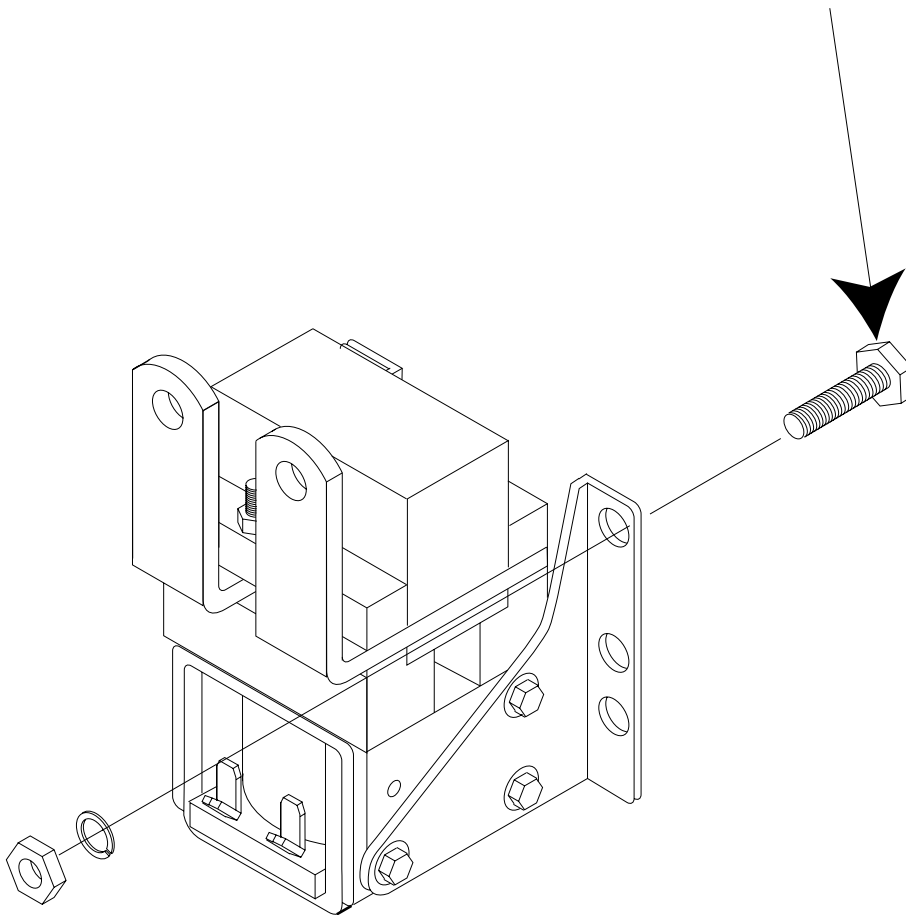

**RETEST AFTER REPAIR****INPUT IDLE AMPS AND WATTS**

Input Volts/Hertz	Maximum Idle Amps	Maximum Idle Watts
230/60	2.0	150

**OPEN CIRCUIT VOLTAGE**

35 - 40 VDC

**WIRE SPEED RANGE**

50 - 700 IPM (1.27 - 17.8 m/minute)

**TABLE OF CONTENTS  
-ELECTRICAL DIAGRAMS SECTION-**

ELECTRICAL DIAGRAMS .....	SECTION G
WIRING DIAGRAM .....	G-2
CONTROL PC BOARD SCHEMATIC .....	G-3
CONTROL PC BOARD ASSEMBLY .....	G-4

Return to Master TOC

Return to Master TOC

Return to Master TOC

Return to Master TOC

WIRING DIAGRAM -

# POWER MIG 200 (208/230V)

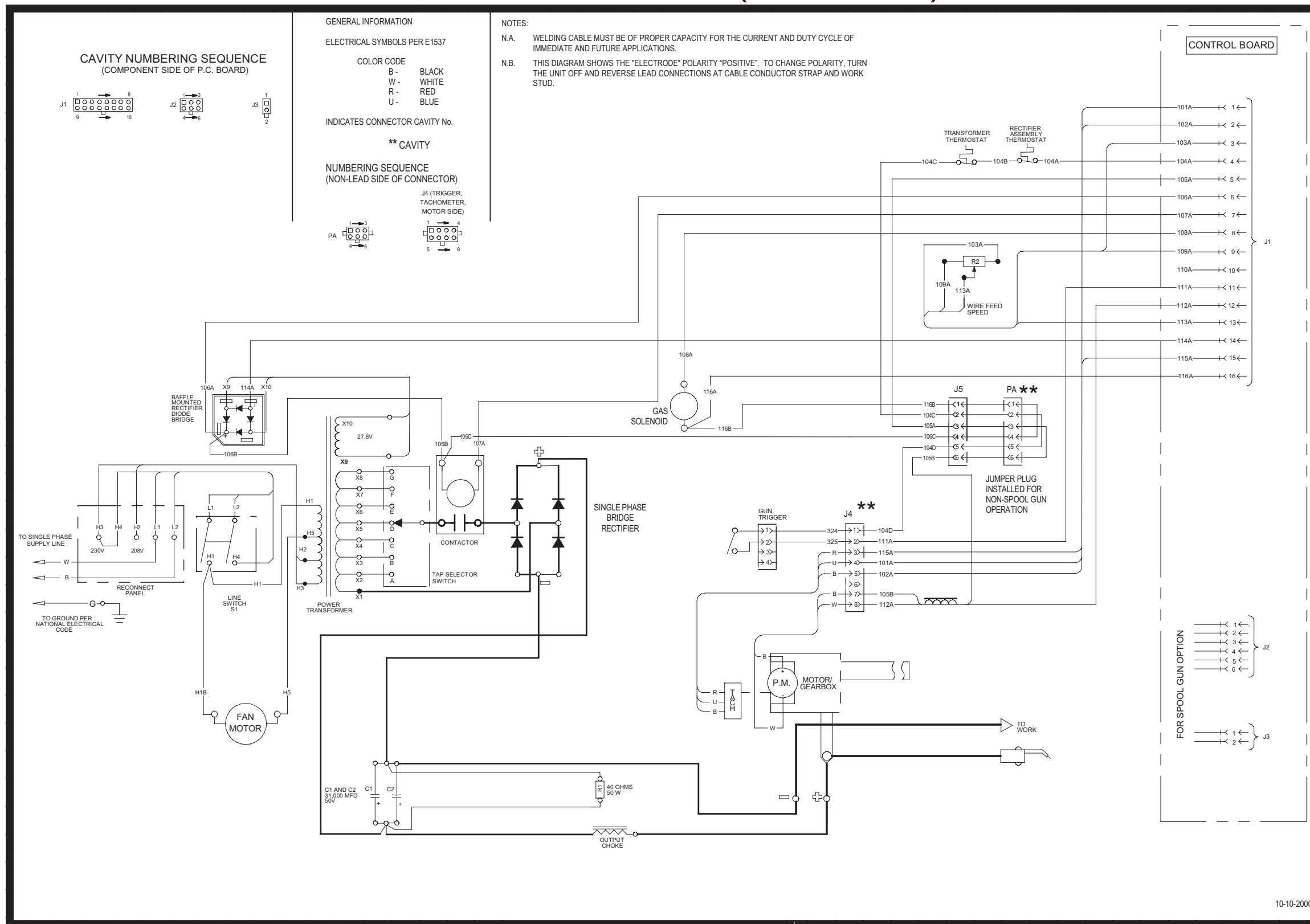

10-10-2000

Return to Section TOC

Return to Section TOC

Return to Section TOC

Return to Section TOC

**L11424**

**POWER MIG 200**

**NOTE:** This diagram is for reference only. It may not be accurate for all machines covered by this manual. The wiring diagram specific to your code is pasted inside one of the enclosure panels of your machine.



SCHEMATIC - CONTROL PC BOARD

Return to Section TOC  
Return to Master TOC

Return to Section TOC  
Return to Master TOC

Return to Section TOC  
Return to Master TOC

Return to Section TOC  
Return to Master TOC

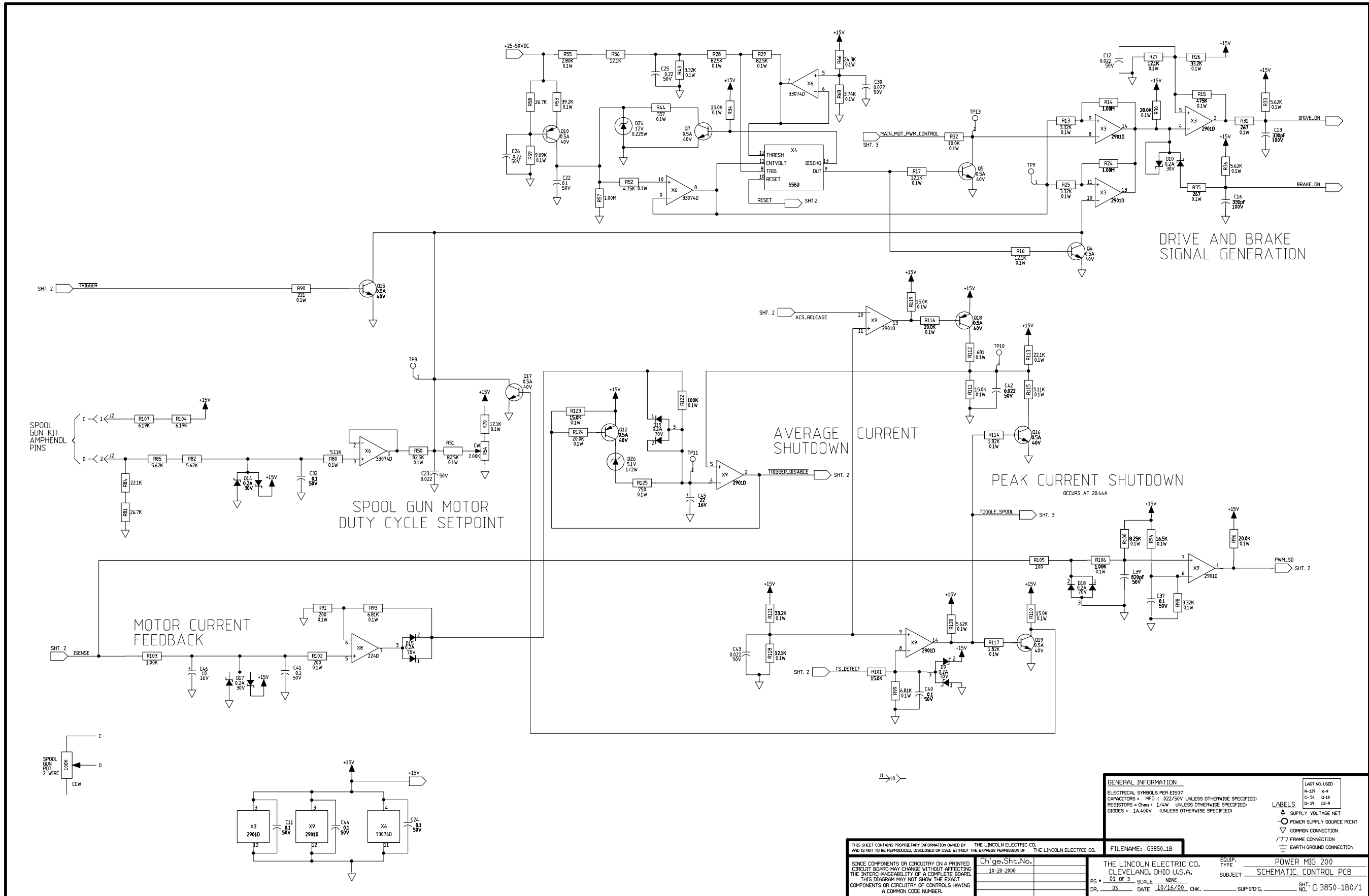

NOTE: This diagram is for reference only. It may not be accurate for all machines covered by this manual.

POWER MIG 200



THIS SHEET CONTAINS PROPRIETARY INFORMATION OWNED BY THE LINCOLN ELECTRIC CO. AND IS NOT TO BE REPRODUCED, DISCLOSED OR USED WITHOUT THE EXPRESS PERMISSION OF THE LINCOLN ELECTRIC CO.		FILENAME: G3850_1B
SINCE COMPONENTS OR CIRCUITRY ON A PRINTED CIRCUIT BOARD MAY CHANGE WITHOUT AFFECTING THE INTERCHANGEABILITY OF A COMPLETE BOARD, THIS DIAGRAM MAY NOT SHOW THE EXACT COMPONENTS OR CIRCUITRY OF CONTROLS HAVING A COMMON CODE NUMBER.		Ch'ge.Sht.No. 10-20-2000
THE LINCOLN ELECTRIC CO. CLEVELAND, OHIO U.S.A.		EQUIP. TYPE POWER MIG 200
PG. 01 OF 3 SCALE NONE		SUBJECT SCHEMATIC, CONTROL PCB
DR. DS DATE 10/16/00 CHK. _____		SUP'S'D'G. SHT. NO. G 3850-1B0/1



# SVM ERROR REPORTING FORM

We need to know if there are errors in our manuals. We also value any suggestions as to additional tests or procedures that would make this SVM a better tool for you.

If you discover new or different "Problems or Symptoms" that are not covered in the three column troubleshooting chart, please share this information with us. Please include the machine's code number and how the problem was resolved.

Thank You,  
Technical Services Group  
Lincoln Electric Co.  
22801 ST. Clair Ave.  
Cleveland, Ohio 44117-1199

FAX 216-481-2309

SVM Number \_\_\_\_\_

Page Number if necessary \_\_\_\_\_

Your Company \_\_\_\_\_

Your Name \_\_\_\_\_

Please give detailed description below:

---

---

---

---

---

---

---

---

---

---

---

---

---

---

---

---

SD287 01/99

